

Linear units SLE



Linear units SLE

Key features

FESTO

Version

The linear unit SLE is a combination of a guide unit and a standard cylinder. The cylinder moves a flange plate.

The modular system allows for individualised end-position cushioning and end-position sensing solutions.

Basic unit

SLE-...-G

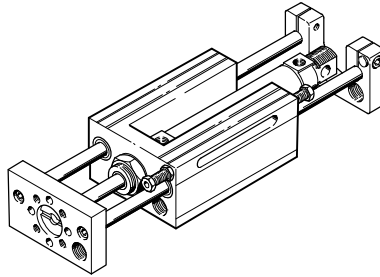

Standard unit

SLE-...-S

with two self-adjusting shock absorbers and two inductive proximity sensors with PNP output

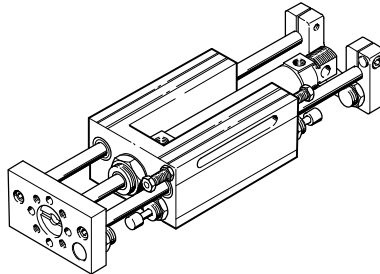

Linear units SLE

Key features

Multi-axis combinations

The linear unit SLE can be combined with a further linear unit SLE or a linear drive SLM to produce a range of 2-axis or 3-axis systems.

The units are bolted together directly for multi-axis operation.

The centring pins and sleeves required to secure the units together are included in the scope of delivery.

Linear drive SLM
→ Internet: slm

with linear unit SLE

X-Y-unit
with SLE/SLE

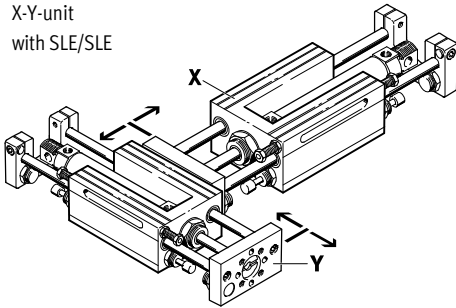

X	Y	Z
2 axes		
SLE-16	SLE-10	–
SLE-20	SLE-16	–
SLE-25	SLE-16	–
SLE-32	SLE-20 or SLE-25	–
SLE-40	SLE-32	–
SLE-50	SLE-40	–
3 axes		
SLE-20	SLE-16	SLE-10
SLE-25	SLE-16	SLE-10
SLE-32	SLE-20 or SLE-25	SLE-16
SLE-40	SLE-32	SLE-20 or SLE-25
SLE-50	SLE-40	SLE-32

with linear drive SLM

X-Y-Z-unit
with SLM/SLE/SLE

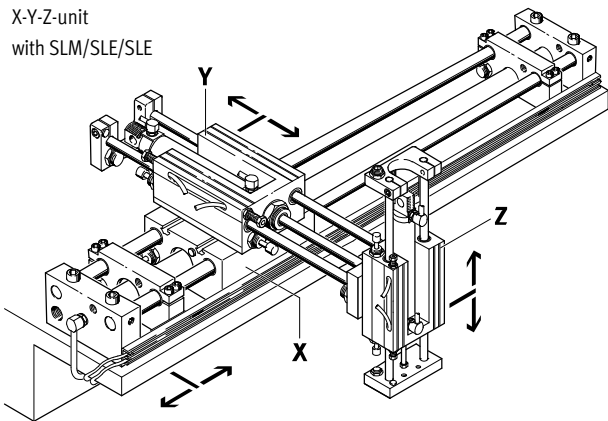

X	Y	Z
2 axes		
SLM-12	SLE-10	–
SLM-20	SLE-16	–
SLM-32	SLE-20 or SLE-25	–
SLM-40	SLE-32	–
3 axes		
SLM-20	SLE-16	SLE-10
SLM-32	SLE-20 or SLE-25	SLE-16
SLM-40	SLE-32	SLE-20 or SLE-25

Linear units SLE

Peripherals overview

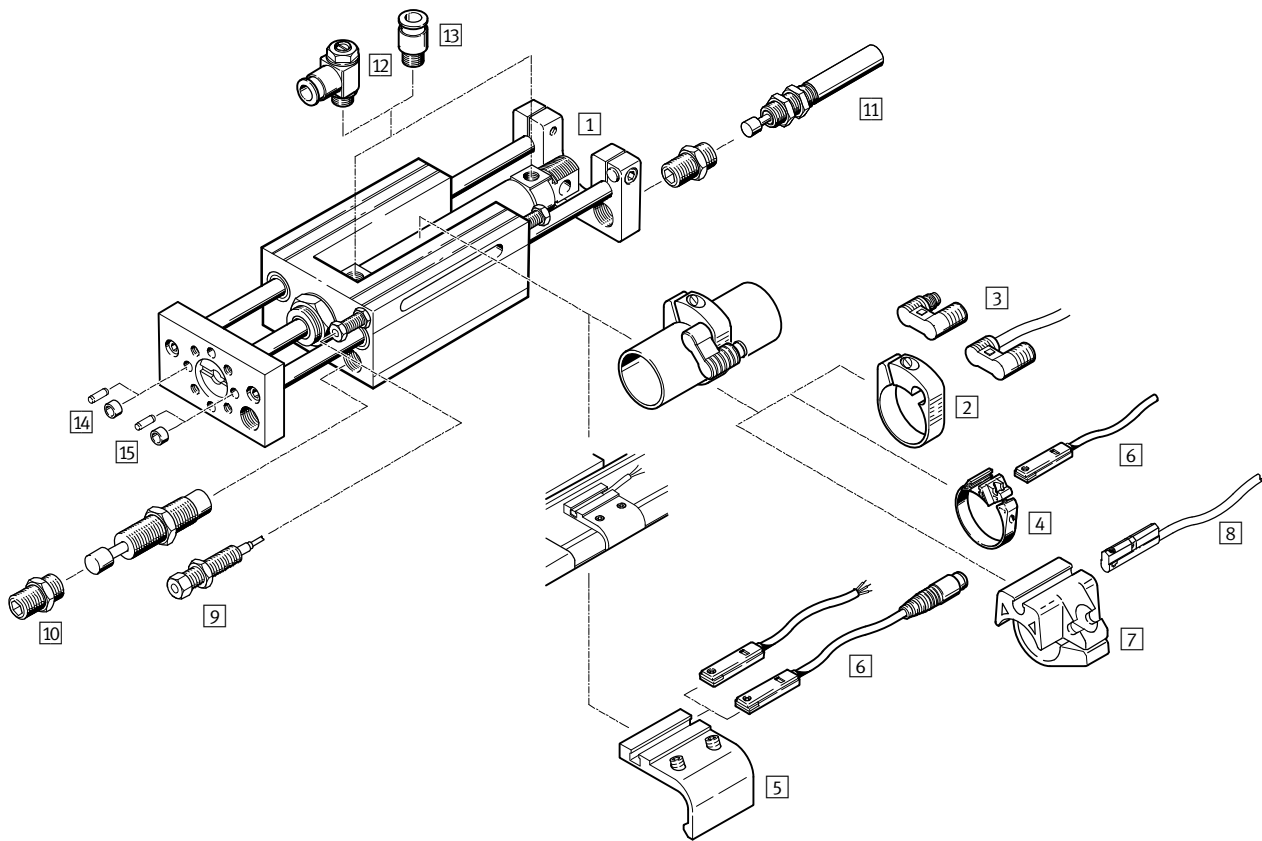

Linear units SLE

Peripherals overview

FESTO

Accessories						
	Brief description	Piston Ø 10 ... 20 mm	Piston Ø 25 mm	Piston Ø 32 ... 50 mm	→ Page/Internet	
1	Standard cylinder DSNU	Drive for the flange plate	■	■	-	17
	Standard cylinder DNC	Drive for the flange plate	-	-	■	17
2	Mounting kit SMBR	For attachment to standard cylinder DSNU	■	■	-	17
3	Proximity sensor SMEO/SMT0-4J	Can be integrated in mounting kit SMBR	■	■	-	17
4	Mounting kit SMBR-8	For attachment to standard cylinder DSNU	■ Ø 20	■	-	18
5	Mounting kit SMB-8-FENG	For attachment to standard cylinder DNC	-	-	■	18
6	Proximity sensor SME/SMT-8	Can be integrated in mounting kit SMBR-8 or SMB-8-FENG	■ Ø 20	■	■	18
7	Mounting kit SMBR-10	For attachment to standard cylinder DSNU	■ Ø 20	■	-	19
8	Proximity sensor SME/SMT-10	Can be integrated in mounting kit SMBR-10	■ Ø 20	■	-	19
9	Switching stop with proximity sensor SL-...-SIE-PS/SL-...-SIE-NS	Can be integrated in end plate	■	■	■	16
10	Shock absorber kit, self-adjusting SLE-...-YSR-C	For slowing higher speeds to a stop	■	■	■	16
11	Shock absorber kit, adjustable SLZ-...-KF-A	For slowing higher speeds to a stop	■ Ø 20	■	■	16
12	One-way flow control valve GRLA	For speed regulation	■	■	■	20
13	Push-in fitting QS	For connecting compressed air tubing with standard O.D.	■	■	■	quick star
14	Centring pin ZBS	For centring loads and attachment components	■	-	-	17
15	Centring sleeve ZBH	For centring loads and attachment components	-	■	■	17

Linear units SLE

Type codes

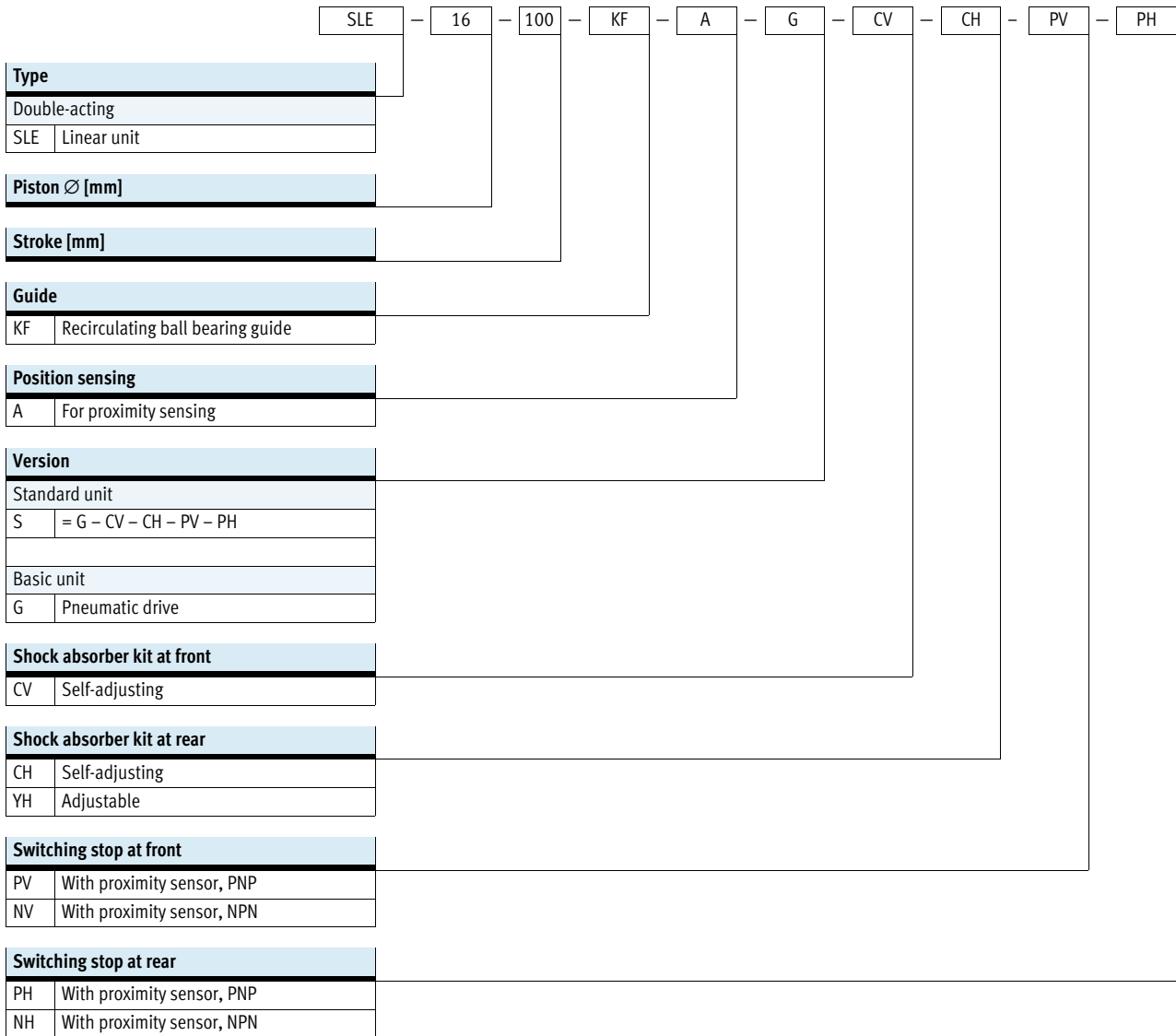

Linear units SLE

Technical data

Function



 www.festo.com

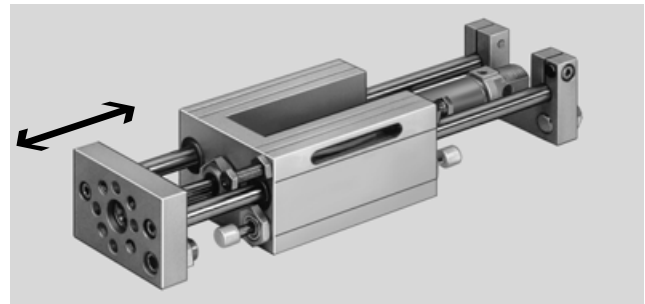

- \varnothing - Diameter
10 ... 50 mm
- | - Stroke length
10 ... 500 mm

General technical data							
Piston \varnothing	10	16	20	25	32	40	50
Stroke [mm]	10 ... 100		10 ... 200		10 ... 320		10 ... 500
Pneumatic connection	M5			G $\frac{1}{8}$		G $\frac{1}{4}$	
Mode of operation	Double-acting						
Constructional design	Linear unit						
	Standard cylinder						
End-position cushioning via shock absorber	Self-adjusting at both ends						
	-			Adjusted from the rear			
Position sensing	For proximity sensing						
Type of mounting	Via through-holes						
	Via female thread						
Mounting position	Any						
Protection against torsion/guide	Guide rods with yoke/ball bearing guide						

Operating and environmental conditions								
Piston \varnothing	10	16	20	25	32	40	50	
Operating medium	Compressed air in accordance with ISO 8573-1:2010 [7:4:4]							
Note on operating/pilot medium	Operation with lubricated medium possible (in which case lubricated operation will always be required)							
Operating pressure [bar]	2.5 ... 10				1.5 ... 12			
Ambient temperature ¹⁾ [°C]	-20 ... +80							

1) Note operating range of proximity sensors.

Forces [N]							
Piston \varnothing	10	16	20	25	32	40	50
Theoretical force at 6 bar, advancing	47	121	188	295	483	754	1178
Theoretical force at 6 bar, retracting	40	104	158	247	415	633	990

Linear units SLE

Technical data

Permissible dynamic load

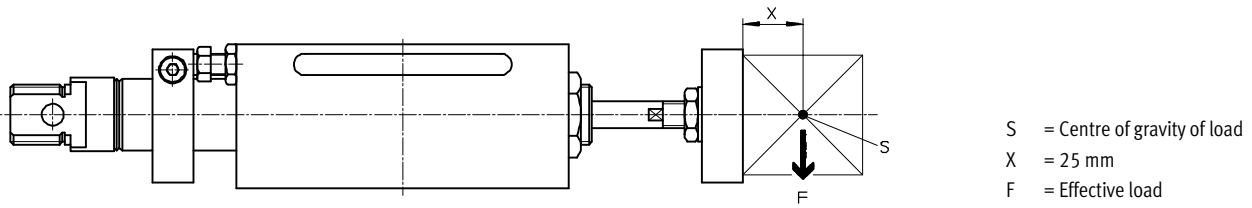

Permissible effective load F as a function of the stroke l

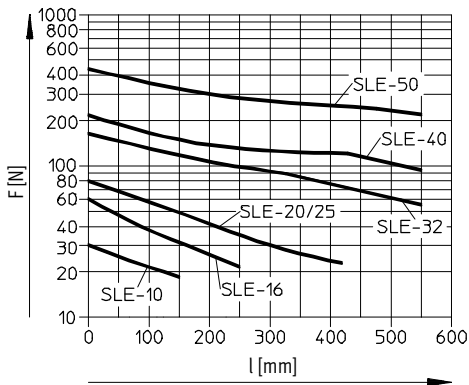

Permissible torque M as a function of the stroke l

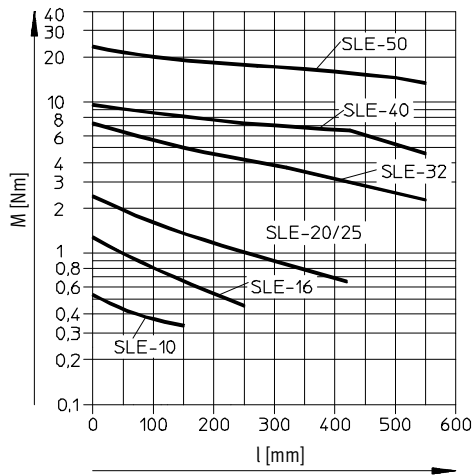

Permissible shock absorber load F as a function of the impact velocity v with horizontal installation

$$F \geq m_L \times g$$

$g = 9.81 \text{ N/mm}^2$
 $m_L = \text{Load [kg]}$

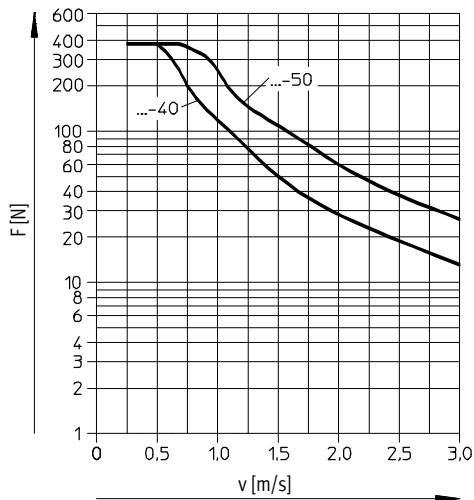
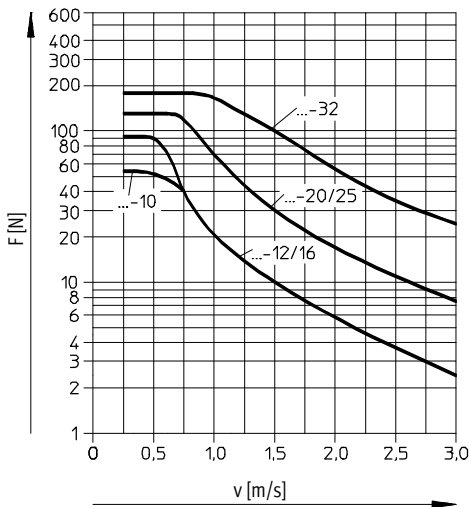

Linear units SLE

Technical data

Permissible shock absorber load F as a function of the impact velocity v
with vertical installation

$$F \geq (m_L + m_E) \times g$$

$$g = 9.81 \text{ N/mm}^2$$

m_E = Moving load (dead weight) [kg]

m_L = Load [kg]

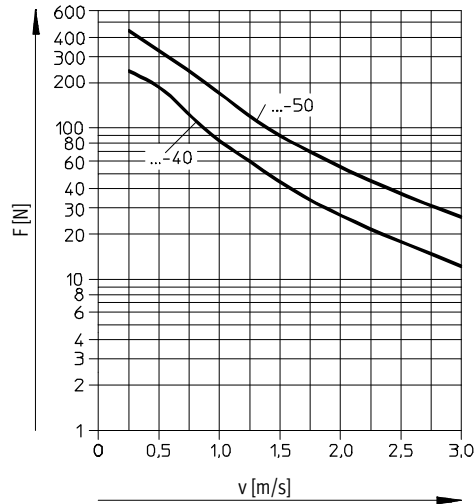
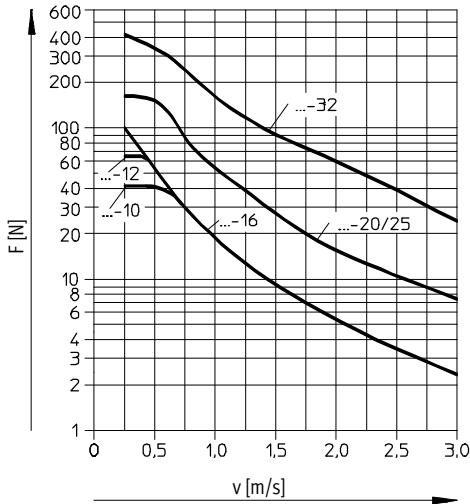

Weights [g]							
Piston Ø	10	16	20	25	32	40	50
Product weight with 0 mm stroke	560	913	1882	1942	4300	6175	9200
Additional weight per 10 mm stroke	10	13	19	23	57	85	125
Moving load with 0 mm stroke	160	230	500	500	1500	2200	3600
Additional load per 10 mm stroke	8	8	12	12	31	49	77

Linear units SLE

Technical data

FESTO

Materials

Sectional view

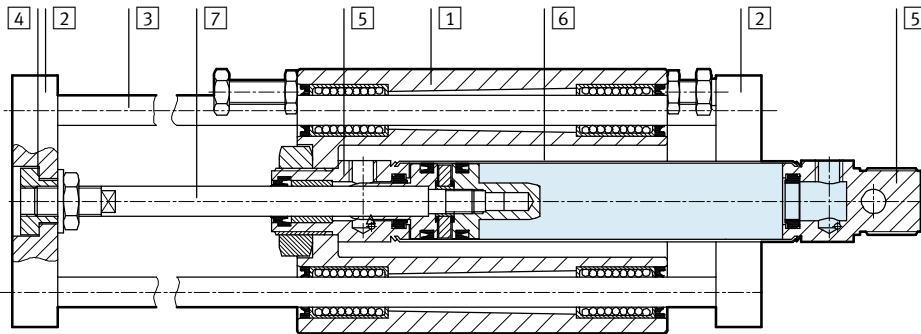

Linear unit

1	Housing	∅ 10 ... 25	Die-cast aluminium
		∅ 32 ... 50	Wrought aluminium alloy
2	Yoke/end plate		Aluminium
3	Guide rod		Tempered steel
4	Coupling		Steel
5	Bearing and end caps	∅ 10 ... 25	Wrought aluminium alloy
		∅ 32 ... 50	Die-cast aluminium
6	Cylinder barrel	∅ 10 ... 25	High-alloy stainless steel
		∅ 32 ... 50	Wrought aluminium alloy
7	Piston rod	∅ 10 ... 25	High-alloy stainless steel
		∅ 32 ... 50	High-alloy steel
-	Seals		Polyurethane, nitrile rubber

Linear units SLE

Technical data

FESTO

Dimensions

Piston \varnothing 10 mm

Download CAD data → www.festo.com

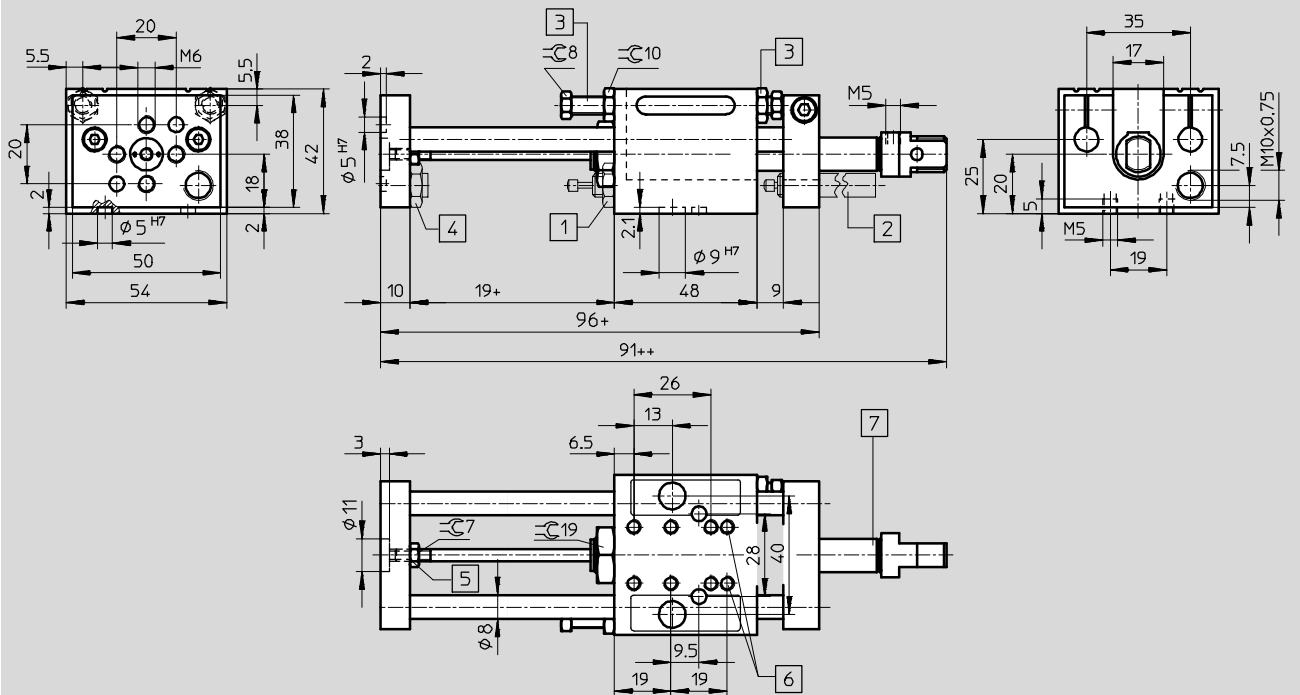

- 1 Self-adjusting shock absorber, for front and rear mounting
- 2 Adjustable shock absorber, can only be mounted to yoke at rear

- 3 Switching stop with proximity sensor, PNP/NPN, for front and rear mounting
- 4 Shock absorber stop

- 5 Compensating coupling for radial and axial alignment
- 6 Mounting thread
- 7 Drive DSNU

+ = plus stroke length
 ++ = plus 2x stroke length

Linear units SLE

Technical data



Dimensions

Piston \varnothing 16 ... 25 mm

Download CAD data → www.festo.com

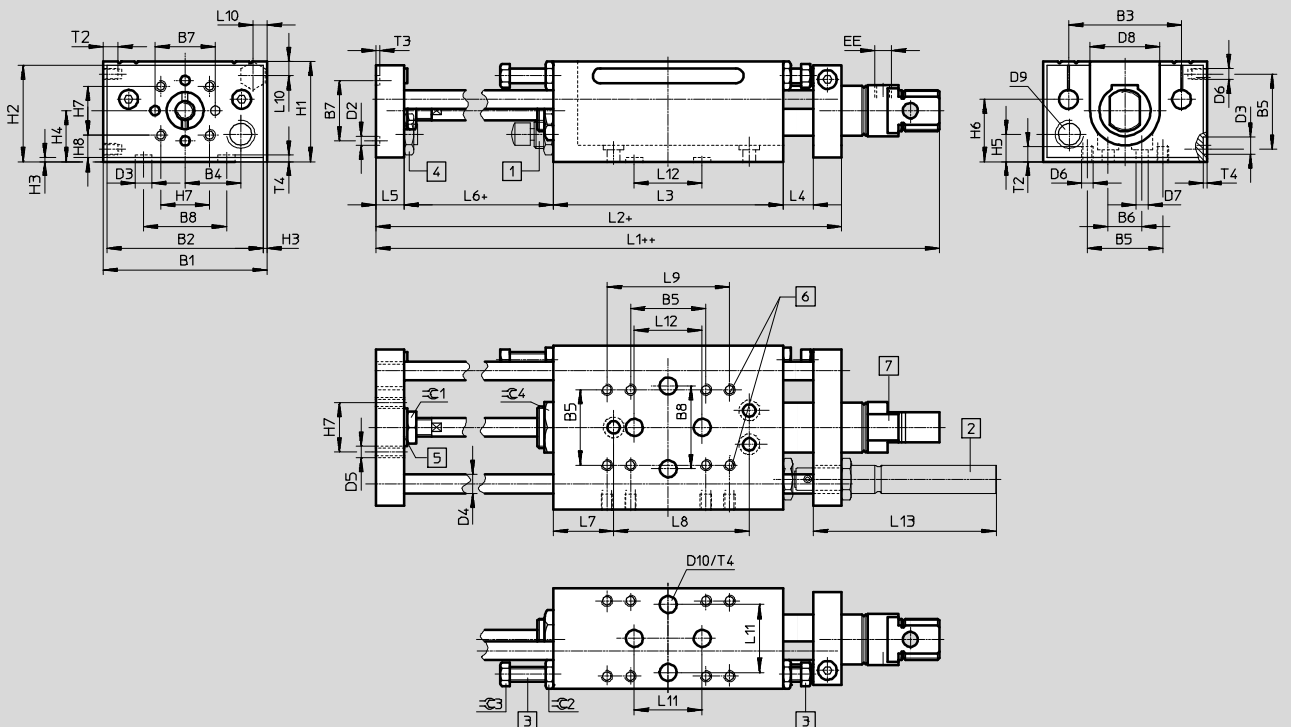

- 1 Self-adjusting shock absorber, for front and rear mounting
 - 2 Adjustable shock absorber, can only be mounted to yoke at rear
 - 3 Switching stop with proximity sensor, PNP/NPN, for front and rear mounting
 - 4 Shock absorber stop
 - 5 Compensating coupling for radial and axial alignment
 - 6 Mounting thread
 - 7 Drive DSNU
- + = plus stroke length
++ = plus 2x stroke length

\varnothing	B1	B2	B3	B4	B5	B6	B7	B8	D2	D3	D4	D5	D6	D7	D8
[mm]			± 0.03					± 0.03	\varnothing H7	\varnothing H7	\varnothing h6			\varnothing	
16	64	60	44	22	26	14	28	40	5	9	8	M6	M5	5.5	26
20	87	83	60	29.5	40	18	32	40	5	9	10	M6	M6	6.6	37
25	87	83	60	29.5	40	18	32	40	5	9	10	M6	M6	6.6	37

\varnothing	D9	D10	EE	H1	H2	H3	H4	H5	H6	H7	H8	L1	L2	L3	L4
[mm]		\varnothing H7							± 0.1						
16	M10x0.75	5	M5	43	39	2	22	10	25	19	10.5	116	143	86	12
20	M15x1	9	G $\frac{1}{8}$	53	49	2	27	14.5	33	26	12	145.5	197	122	16
25	M15x1	9	G $\frac{1}{8}$	53	49	2	27	14.5	33	26	12	149	197	122	16

\varnothing	L5	L6	L7	L8	L9	L10	L11	L12	L13	T2	T3	T4	$\approx C1$	$\approx C2$	$\approx C3$	$\approx C4$
[mm]				± 0.2			± 0.03	± 0.03								
16	12	21	21	54	40	6	-	32	-	7	2	2	10	10	8	19
20	15	29	32	72	65	7.5	40	40	97	8	2	2.1 ^{+0.2}	13	13	11	27
25	15	29	32	72	65	7.5	40	40	97	8	2	2.1 ^{+0.2}	17	13	11	27

Linear units SLE

Technical data



Dimensions

Piston \varnothing 32 ... 50 mm

Download CAD data → www.festo.com

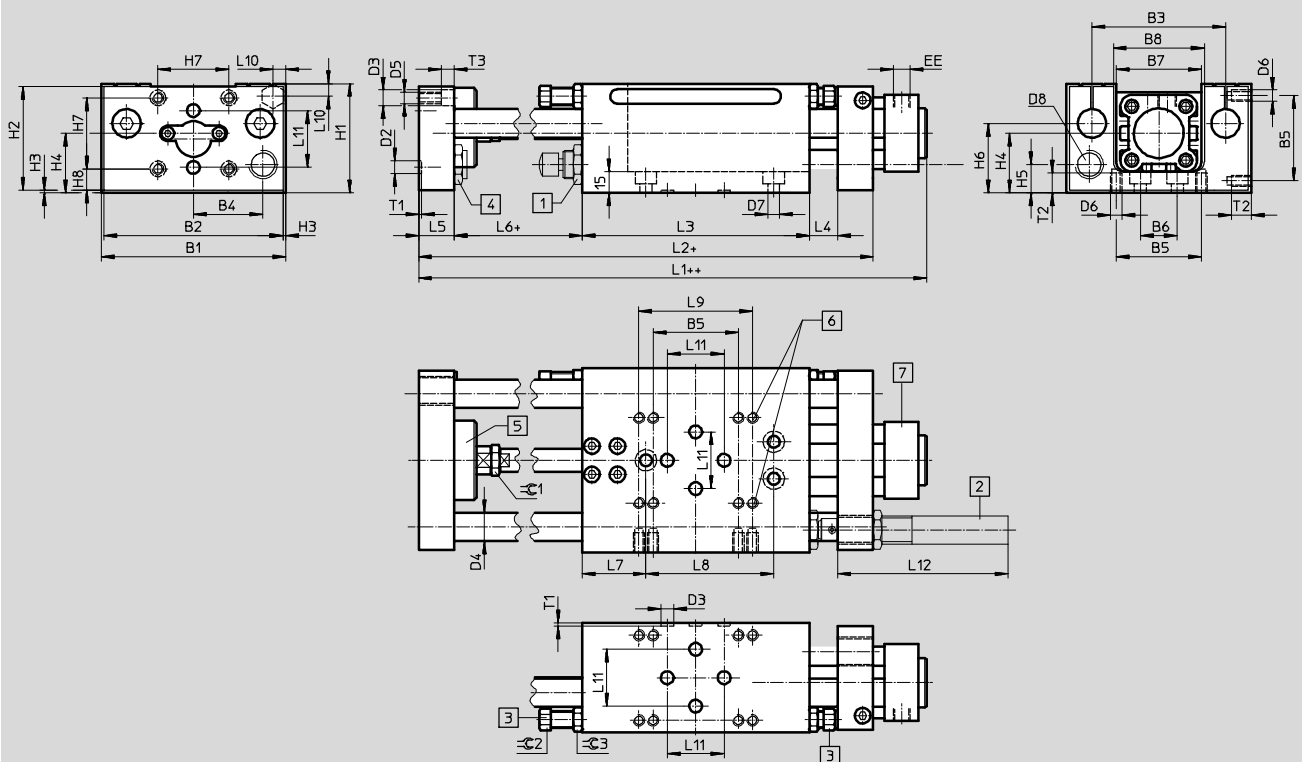

- 1 Self-adjusting shock absorber, for front and rear mounting
 - 2 Adjustable shock absorber, can only be mounted to yoke at rear
 - 3 Switching stop with proximity sensor, PNP/NPN, for front and rear mounting
 - 4 Shock absorber stop
 - 5 Compensating coupling for radial and axial alignment
 - 6 Mounting thread
 - 7 Drive DNC
- + = plus stroke length
 ++ = plus 2x stroke length

\varnothing	B1	B2	B3	B4	B5	B6	B7	B8	D2	D3	D4	D5	D6	D7
[mm]			± 0.03						\varnothing H7	\varnothing	\varnothing h6			\varnothing
32	115	111	84	41.5	50	26	52	55	9	11	16	M8	M6	8.4
40	130	126	94	49	60	26	60	64	9	11	20	M8	M8	8.4
50	154	150	113	58	60	30	72	76	9	15	25	M10	M8	8.4

\varnothing	D8	EE	H1	H2	H3	H4	H5	H6	H7	H8	L1	L2
[mm]								± 0.1				
32	M20x1.25	G $\frac{1}{8}$	70	66	2	40.5	17	43	40	18.5	172	250
40	M20x1.25	G $\frac{1}{4}$	77	73	2	46	20	49	50	15	196	260
50	M24x1.25	G $\frac{1}{4}$	90	86	2	53.5	19	52	60	16.5	213	305

\varnothing	L3	L4	L5	L6	L7	L8	L9	L10	L11	L12	T1	T2	T3	$\approx C1$	$\approx C2$	$\approx C3$
[mm]									± 0.03	max.	+0.2					
32	160	20	20	30	45	90	75	9	40	115	2.1	10	7.3	17	13	15
40	160	20	25	30	45	90	80	9	40	115	2.1	14	9	19	13	15
50	192	25	25	38	66	90	80	10	40	138	2.1	14	11	24	13	15

Linear units SLE

Ordering data – Modular products



M Mandatory data							O Options			
Module No.	Drive function	Size	Stroke	Guide	Position sensing	Basic unit	Shock absorber at front	Shock absorber at rear	Sensor at front	Sensor at rear
150 088	SLE	10	10 ... 500	KF	A	G	CV	CH	PV	PH
150 090		16					YV	YH	NV	NH
150 091		20								
150 092		25								
150 093		32								
150 094		40								
150 921		50								
Ordering example										
150 090	SLE	- 16	- 190	- KF	- A	- G	- YV	- YH	- PV	- PH

Ordering table												
Size	10	16	20	25	32	40	50	Condi-tions	Code	Enter code		
M Module No.	150 088	150 090	150 091	150 092	150 093	150 094	150 921					
Drive function	Linear unit								SLE		SLE	
Size [mm]	10	16	20	25	32	40	50		-...			
Stroke [mm]	10 ... 100	10 ... 200	10 ... 320	10 ... 500					-...			
Guide	Via ball bearings								-KF		-KF	
Position sensing	For proximity sensing								-A		-A	
Basic unit	Linear unit with pneumatic drive								-G		-G	
O Shock absorber	at front	Self-adjusting shock absorber, with stop at front								-CV		
	at rear	Self-adjusting shock absorber, with stop at rear								-CH		
		-	-	Adjustable shock absorber, with stop at rear						-YH		
Sensor (bonded)	at front	Inductive sensor with 2.5 m cable, PNP, with stop sleeve at front								-PV		
		Inductive sensor with 2.5 m cable, NPN, with stop sleeve at front								-NV		
	at rear	Inductive sensor with 2.5 m cable, PNP, with stop sleeve at rear								-PH		
		Inductive sensor with 2.5 m cable, NPN, with stop sleeve at rear								-NH		

Transfer order code

SLE - - - **KF** - **A** - **G** - - - -

Linear units SLE

Ordering data – Modular products, package solution

M Mandatory data

Module No.	Drive function	Size	Stroke	Guide	Position sensing	Standard unit
150 088	SLE	10	10 ... 500	KF	A	S
150 090		16				
150 091		20				
150 092		25				
150 093		32				
150 094		40				
150 921		50				
Ordering example						
150 093	SLE	- 32	- 450	- KF	- A	- S

Ordering table

Size	10	16	20	25	32	40	50	Condi- tions	Code	Enter code
M Module No.	150 088	150 090	150 091	150 092	150 093	150 094	150 921			
Drive function	Linear unit								SLE	SLE
Size [mm]	10	16	20	25	32	40	50		-...	
Stroke [mm]	10 ... 100	10 ... 200	10 ... 320		10 ... 500				-...	
Guide	Via ball bearings								-KF	-KF
Position sensing	For proximity sensing								-A	-A
Standard unit	Package solution S = G-CV-CH-PV-PH								-S	-S

Transfer order code

Linear units SLE

Accessories

FESTO

Shock absorber kit

SLE-...-YSR-C, self-adjusting
(order code CV, CH)

Material:

YSR-8-8-C: Nickel-plated brass
YSR-12-12-C, YSR-16-20-C,
YSR-20-25-C: Galvanised steel
Free of copper, PTFE and silicone



Ordering data			
For Ø [mm]	Including shock absorber	Part No.	Type
10	YSR-8-8-C	116 246	SLE-10-YSR-C
16	YSR-8-8-C	116 247	SLE-16-YSR-C
20, 25	YSR-12-12-C	116 248	SLE-20/25-YSR-C
32	YSR-16-20-C	116 249	SLE-32-YSR-C
40	YSR-16-20-C	116 250	SLE-40-YSR-C
50	YSR-20-25-C	118 698	SLE-50-YSR-C

Shock absorber kit

SLZ-...-KF-A, adjustable
(order code YV, YH)

Material:

Galvanised steel



Ordering data			
For Ø [mm]	Including shock absorber	Part No.	Type
20, 25	DYSR-12-12-Y5	114 032	SLZ-25-KF-A
32, 40	DYSR-16-20-Y5	114 033	SLZ-32-KF-A
50	DYSR-20-25-Y5	114 034	SLZ-50-KF-A

Switching stop SL-...-SIE-PS

(order code PV, PH)

Kit with inductive proximity sensor
PNP

Switching stop SL-...-SIE-NS

(order code NV, NH)

Kit with inductive proximity sensor
NPN





Ordering data				
For Ø [mm]	Switch output	Including proximity sensor	Part No.	Type
10, 16	PNP	SIEN-4B-PS-K-L	116 251	SL-10/16-SIE-PS
	NPN	SIEN-4B-NS-K-L	116 252	SL-10/16-SIE-NS
20, 25	PNP	SIEN-4B-PS-K-L	116 253	SL-20/25-SIE-PS
	NPN	SIEN-4B-NS-K-L	116 254	SL-20/25-SIE-NS
32, 40, 50	PNP	SIEN-6,5B-PS-K-L	117 525	SL-32/50-SIE-PS
	NPN	SIEN-6,5B-NS-K-L	117 526	SL-32/50-SIE-NS

Linear units SLE

Accessories

FESTO

Ordering data – Accessories					
	For Ø [mm]	Material	Part No.	Type	PU ¹⁾
Centring pin ZBS					Technical data → Internet: zbs
	10 ... 20	Stainless steel Free of copper, PTFE and silicone	150 928	ZBS-5	10
Centring sleeve ZBH					Technical data → Internet: zbh
	25 ... 50	Stainless steel Free of copper, PTFE and silicone	150 927	ZBH-9	10

1) Packaging unit quantity

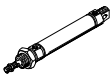
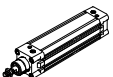
Ordering data – Standard cylinders				Technical data → Internet: standard cylinder			
Designation	For Ø	Part No.	Type	Designation	For Ø	Part No.	Type
Standard cylinder DSNU				Standard cylinder DNC			
	10	14 325	DSNU-10-...-P-A		32	163 304	DNC-32-...-PPV-A
	16	14 320	DSNU-16-...-PPV-A		40	163 336	DNC-40-...-PPV-A
	20	14 321	DSNU-20-...-PPV-A		50	163 368	DNC-50-...-PPV-A
	25	14 322	DSNU-25-...-PPV-A				

Ordering data – Proximity sensors, round design, magneto-resistive							Technical data → Internet: smto	
	Mounting	Switch output	Electrical connection		Cable length [m]	Connection direction	Part No.	Type
			Cable	Plug M8				
Normally open contact								
	Via accessories	PNP	3-wire	–	2.5	In-line	152 836	SMT0-4U-PS-K-LED-24
			–	3-pin	–	–	In-line	152 742
		NPN	3-wire	–	2.5	In-line	152 837	SMT0-4U-NS-K-LED-24
			–	3-pin	–	–	In-line	152 743

Ordering data – Proximity sensors, round design, magnetic reed						Technical data → Internet: smeo		
	Mounting	Electrical connection		Cable length [m]	Connection direction	Part No.	Type	
		Cable	Plug M8					
Normally open contact								
	Via accessories	3-wire	–	2.5	In-line	36 198	SMEO-4U-K-LED-24	
			–	3-pin	–	5	In-line	175 401
		–	–	3-pin	–	In-line	151 526	SMEO-4U-S-LED-24-B

Ordering data – Mounting kits for proximity sensors SMEO/SMT0-4U			Technical data → Internet: smbr	
	For Ø	Part No.	Type	
	10	19 273	SMBR-10	
	16	19 275	SMBR-16	
	20	19 276	SMBR-20	
	25	19 277	SMBR-25	

Linear units SLE

Accessories

FESTO

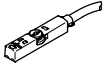
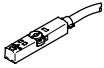
Ordering data – Proximity sensors for T-slot, magneto-resistive						Technical data → Internet: smt
	Type of mounting	Switch output	Electrical connection	Cable length [m]	Part No.	Type
N/O contact						
	Insertable in the slot from above, flush with cylinder profile, short design	PNP	Cable, 3-wire	2.5	574335	SMT-8M-A-PS-24V-E-2,5-OE
			Plug M8x1, 3-pin	0.3	574334	SMT-8M-A-PS-24V-E-0,3-M8D
			Plug M12x1, 3-pin	0.3	574337	SMT-8M-A-PS-24V-E-0,3-M12
		NPN	Cable, 3-wire	2.5	574338	SMT-8M-A-NS-24V-E-2,5-OE
			Plug M8x1, 3-pin	0.3	574339	SMT-8M-A-NS-24V-E-0,3-M8D
N/C contact						
	Insertable in the slot from above, flush with cylinder profile, short design	PNP	Cable, 3-wire	7.5	574340	SMT-8M-A-PO-24V-E-7,5-OE

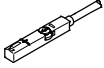
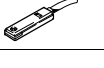
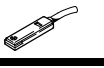
Ordering data – Proximity sensors for T-slot, magnetic reed						Technical data → Internet: sme
	Type of mounting	Switch output	Electrical connection	Cable length [m]	Part No.	Type
N/O contact						
	Insertable in the slot from above, flush with cylinder profile	Contacting	Cable, 3-wire	2.5	543 862	SME-8M-DS-24V-K-2,5-OE
			Cable, 2-wire	2.5	543 872	SME-8M-ZS-24V-K-2,5-OE
			Plug M8x1, 3-pin	0.3	543 861	SME-8M-DS-24V-K-0,3-M8D
			Plug M8x1, 3-pin	0.3	543 861	SME-8M-DS-24V-K-0,3-M8D
	Insertable in the slot lengthwise, flush with the cylinder profile	Contacting	Cable, 3-wire	2.5	150 855	SME-8-K-LED-24
			Plug M8x1, 3-pin	0.3	150 857	SME-8-S-LED-24
N/C contact						
	Insertable in the slot lengthwise, flush with the cylinder profile	Contacting	Cable, 3-wire	7.5	160 251	SME-8-O-K-LED-24

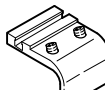

Ordering data – Mounting kits for proximity sensors SME/SMT-8						Technical data → Internet: smb	
	For Ø	Part No.	Type		For Ø	Part No.	Type
	20	175 095	SMBR-8-20		32	175 705	SMB-8-FENG-32/40
	25	175 096	SMBR-8-25		40	175 706	SMB-8-FENG-50/63
					50		

Linear units SLE



Accessories

FESTO

Ordering data – Proximity sensors for C-slot, magneto-resistive						Technical data → Internet: smt	
	Type of mounting	Switch output	Electrical connection, connection direction	Cable length [m]	Part No.	Type	
N/O contact							
	Insertable in the slot from above	PNP	Cable, 3-wire, in-line	2.5	551 373	SMT-10M-PS-24V-E-2,5-L-OE	
			Plug M8x1, 3-pin, in-line	0.3	551 375	SMT-10M-PS-24V-E-0,3-L-M8D	
			Plug M8x1, 3-pin, lateral	0.3	551 376	SMT-10M-PS-24V-E-0,3-Q-M8D	

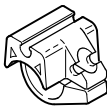
Ordering data – Proximity sensors for C-slot, magnetic reed						Technical data → Internet: sme	
	Type of mounting	Switch output	Electrical connection, connection direction	Cable length [m]	Part No.	Type	
N/O contact							
	Insertable in the slot from above	Contacting	Plug M8x1, 3-pin, in-line	0.3	551 367	SME-10M-DS-24V-E-0,3-L-M8D	
			Cable, 3-wire, in-line	2.5	551 365	SME-10M-DS-24V-E-2,5-L-OE	
			Cable, 2-wire, in-line	2.5	551 369	SME-10M-ZS-24V-E-2,5-L-OE	
	Insertable in the slot lengthwise	Contacting	Plug M8x1, 3-pin, in-line	0.3	173 212	SME-10-SL-LED-24	
			Cable, 3-wire, in-line	2.5	173 210	SME-10-KL-LED-24	

Ordering data – Mounting kits for proximity sensors SME/SMT-10					Technical data → Internet: smbr		
	For Ø		Part No.	Type			
	20		175 103	SMBR-10-20			
	25		175 104	SMBR-10-25			

Ordering data – Connecting cables						Technical data → Internet: nebu	
	Electrical connection, left	Electrical connection, right	Cable length [m]	Part No.	Type		
	Straight socket, M8x1, 3-pin	Cable, open end, 3-wire	2.5	541 333	NEBU-M8G3-K-2.5-LE3		
			5	541 334	NEBU-M8G3-K-5-LE3		
	Straight socket, M12x1, 5-pin	Cable, open end, 3-wire	2.5	541 363	NEBU-M12G5-K-2.5-LE3		
			5	541 364	NEBU-M12G5-K-5-LE3		
	Angled socket, M8x1, 3-pin	Cable, open end, 3-wire	2.5	541 338	NEBU-M8W3-K-2.5-LE3		
			5	541 341	NEBU-M8W3-K-5-LE3		
	Angled socket, M12x1, 5-pin	Cable, open end, 3-wire	2.5	541 367	NEBU-M12W5-K-2.5-LE3		
			5	541 370	NEBU-M12W5-K-5-LE3		

Linear units SLE

Accessories



Ordering data – One-way flow control valves			Technical data → Internet: grla		
	Connection		Material	Part No.	Type
	Thread	For tubing OD			
	M5	3	Metal design	193 137	GRLA-M5-QS-3-D
		4		193 138	GRLA-M5-QS-4-D
		6		193 139	GRLA-M5-QS-6-D
	G $\frac{1}{8}$	3		193 142	GRLA- $\frac{1}{8}$ -QS-3-D
		4		193 143	GRLA- $\frac{1}{8}$ -QS-4-D
		6		193 144	GRLA- $\frac{1}{8}$ -QS-6-D
		8		193 145	GRLA- $\frac{1}{8}$ -QS-8-D
	G $\frac{1}{4}$	6		193 146	GRLA- $\frac{1}{4}$ -QS-6-D
		8		193 147	GRLA- $\frac{1}{4}$ -QS-8-D
		10		193 148	GRLA- $\frac{1}{4}$ -QS-10-D

Product Range and Company Overview

A Complete Suite and Company Overview

Our experienced engineers provide complete support at every stage of your development process, including: conceptualization, analysis, engineering, design, assembly, documentation, validation, and production.



Custom Automation Components
Complete custom engineered solutions



Custom Control Cabinets
Comprehensive engineering support and on-site services



Complete Systems
Shipment, stocking and storage services

The Broadest Range of Automation Components

With a comprehensive line of more than 30,000 automation components, Festo is capable of solving the most complex automation requirements.



Electromechanical
Electromechanical actuators, motors, controllers & drivers



Pneumatics
Pneumatic linear and rotary actuators, valves, and air supply



PLCs and I/O Devices
PLC's, operator interfaces, sensors and I/O devices

Supporting Advanced Automation... As No One Else Can!

Festo is a leading global manufacturer of pneumatic and electromechanical systems, components and controls for industrial automation, with more than 16,000 employees in 60 national headquarters serving more than 180 countries. For more than 80 years, Festo has continuously elevated the state of manufacturing with innovations and optimized motion control solutions that deliver higher performing, more profitable automated manufacturing and processing equipment. Our dedication to the advancement of automation extends beyond technology to the education and development of current and future automation and robotics designers with simulation tools, teaching programs, and on-site services.

Quality Assurance, ISO 9001 and ISO 14001 Certifications

Festo Corporation is committed to supply all Festo products and services that will meet or exceed our customers' requirements in product quality, delivery, customer service and satisfaction.

To meet this commitment, we strive to ensure a consistent, integrated, and systematic approach to management that will meet or exceed the requirements of the ISO 9001 standard for Quality Management and the ISO 14001 standard for Environmental Management.

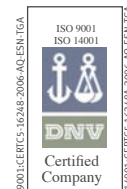

© Copyright 2013, Festo Corporation. While every effort is made to ensure that all dimensions and specifications are correct, Festo cannot guarantee that publications are completely free of any error, in particular typing or printing errors. Accordingly, Festo cannot be held responsible for the same. For Liability and Warranty conditions, refer to our "Terms and Conditions of Sale", available from your local Festo office. All rights reserved. No part of this publication may be reproduced, distributed, or transmitted in any form or by any means, electronic, mechanical, photocopying or otherwise, without the prior written permission of Festo. All technical data subject to change according to technical update.



Printed on recycled paper at New Horizon Graphic, Inc., FSC certified as an environmental friendly printing plant.

Festo North America

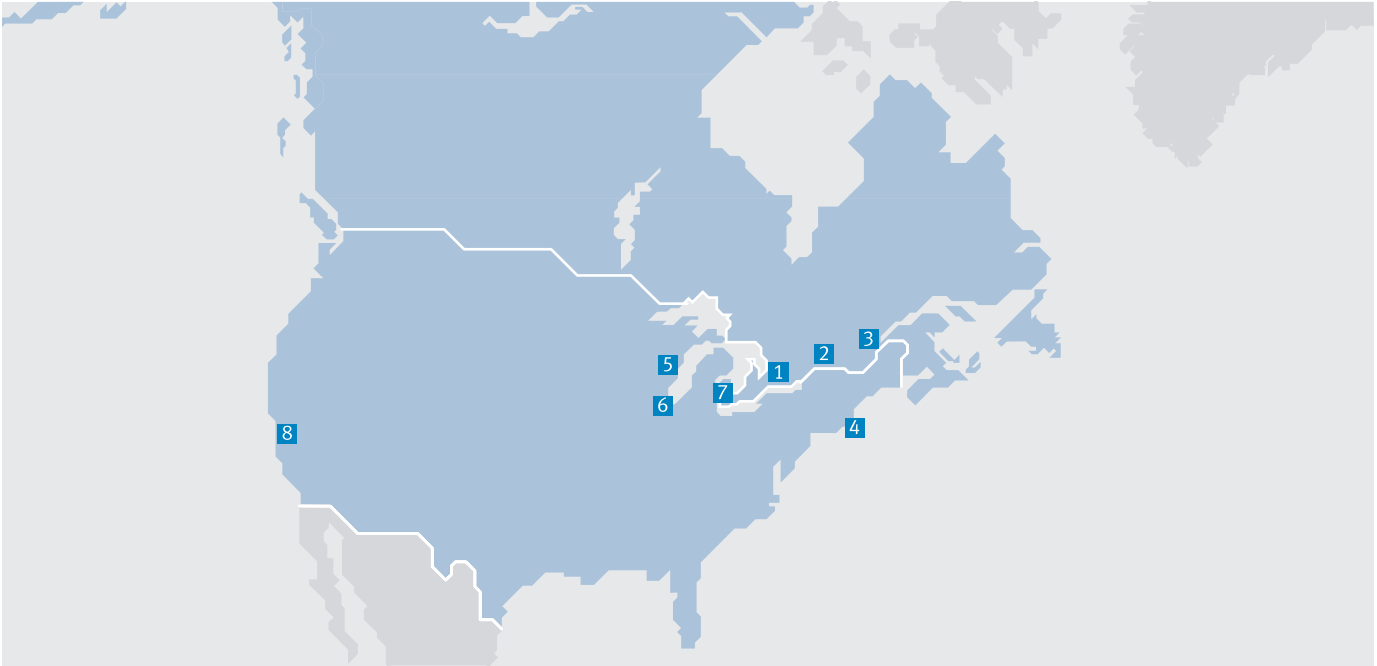

**1 Festo Canada
Headquarters
Festo Inc.**
5300 Explorer Drive
Mississauga, ON
L4W 5G4

2 Montréal
5600, Trans-Canada
Pointe-Claire, QC
H9R 1B6

3 Québec City
2930, rue Watt#117
Québec, QC
G1X 4G3



**4 Festo United States
Headquarters
Festo Corporation**
395 Moreland Road
Hauppauge, NY
11788

5 Appleton
North 922 Tower View Drive, Suite N
Greenville, WI
54942

7 Detroit
1441 West Long Lake Road
Troy, MI
48098

6 Chicago
85 W Algonquin - Suite 340
Arlington Heights, IL
60005

8 Silicon Valley
4935 Southfront Road, Suite F
Livermore, CA
94550

Festo Regional Contact Center

Canadian Customers

Commercial Support:
Tel: 1 877 GO FESTO (1 877 463 3786)
Fax: 1 877 FX FESTO (1 877 393 3786)
Email: festo.canada@ca.festo.com

Technical Support:
Tel: 1 866 GO FESTO (1 866 463 3786)
Fax: 1 877 FX FESTO (1 877 393 3786)
Email: technical.support@ca.festo.com

USA Customers

Commercial Support:
Tel: 1 800 99 FESTO (1 800 993 3786)
Fax: 1 800 96 FESTO (1 800 963 3786)
Email: customer.service@us.festo.com

Technical Support:
Tel: 1 866 GO FESTO (1 866 463 3786)
Fax: 1 800 96 FESTO (1 800 963 3786)
Email: product.support@us.festo.com