

Compact Vision System SBOC-M



Compact Vision System SBOC-M

Key features

FESTO

Problem description

Modern automation systems are for the most part designed for high production speeds which the human eye has trouble following.

Disadvantage of this high speed: Fitters and service employees cannot detect errors in the motion sequence and their causes straight away.

It is also becoming increasingly difficult to set the system parameters to their optimum values.

Typical applications

Mobile deployment of the high-speed camera for service and commissioning to increase the productivity and availability of automation systems

- Cycle time reduction through pinpointing of idle periods in motion sequences
- Optimum harmonisation of the travel times of individual axes in multi-axis systems, localisation of critical movements
- Time-synchronised visualisation of movement processes from several sides on a PC for greater ease of handling
- Localisation of unwanted vibrations which have a negative effect on the repetition accuracy of movement processes and can cause premature material fatigue

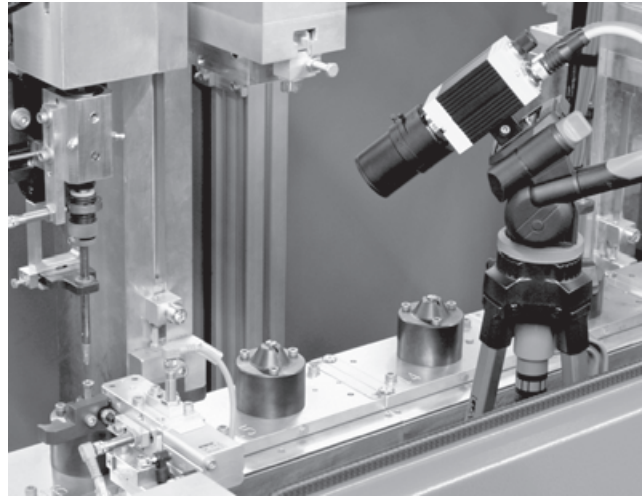

Stationary mounting of the high-speed camera to increase the availability of automation systems

- Continuous recording of processes in the ring buffer of the camera
- If a fault occurs, recording is stopped by an external signal. The case history of the fault is then stored in the camera, thus permitting an analysis of the cause

Interfaces

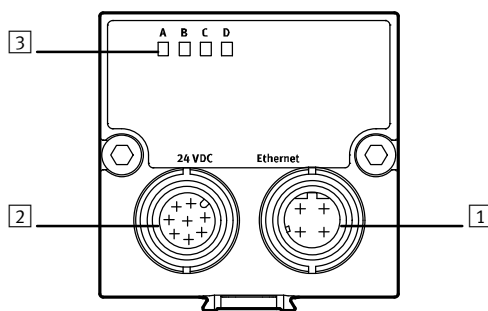

- 1 Ethernet connection
- 2 Power supply and inputs/outputs
- 3 Status LEDs:
 - A Operating system
 - B Ethernet traffic
 - C Recording
 - D Recording status

Compact Vision System SBOC-M

Key features



FCT software with SBO.. Network plug-in

Configuring a camera network

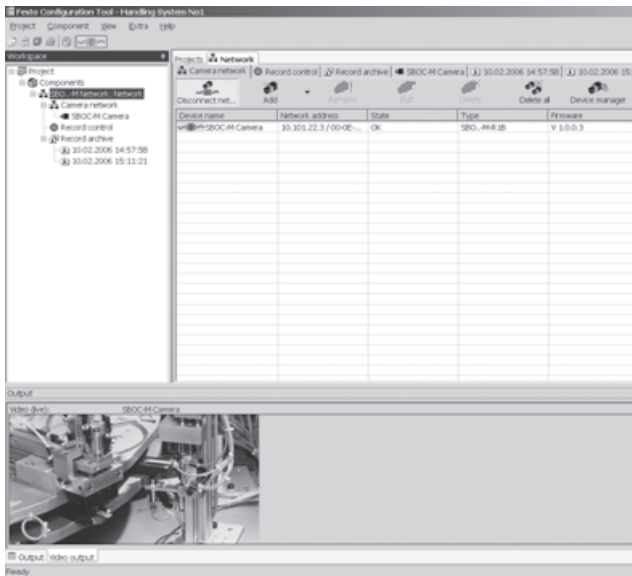

The "SBO..-M Network" is a plug-in for the Festo configuration tool (FCT for short). It provides the following functions:

- Configuration and commissioning of a camera network with any desired number of Compact Vision Systems of the type SBOC-M
- Creation of time-synchronised recordings using all devices in the camera network in order to record a scene from various angles, for example

Setting the camera

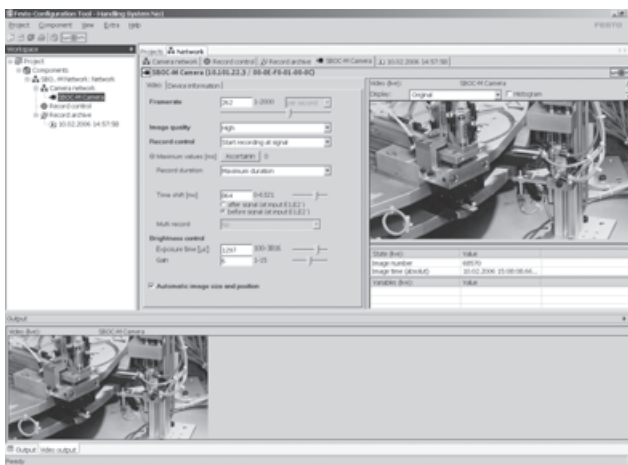

Using the live pictures from the camera, the lens can be set and parameters such as exposure time, frames per second, recording duration and picture quality, for example, adjusted.

With the parameters you can also define what is to happen when a trigger signal (edge change of an external 24 V signal) occurs:

- Start the recording
- Stop the recording
- Record only one picture

Time delays between trigger signal and start of recording or stop recording as well as recording several films or pictures in the camera memory (multi-recording) can also be determined in a user-friendly manner.

Recording control

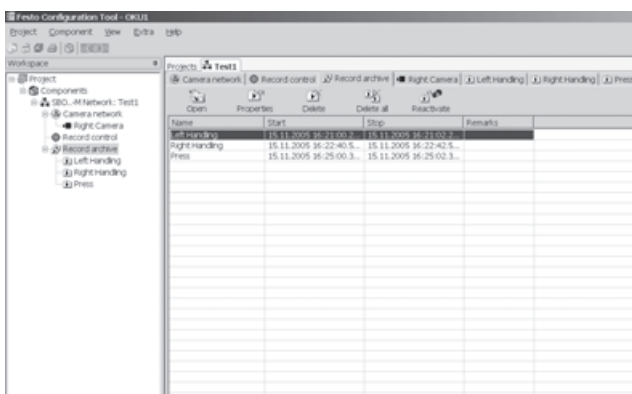

Recording can be started once the camera has been set up. You can choose whether the camera should wait for the occurrence of an external trigger condition, start recording directly following initialisation or store the pictures sent via Ethernet on a PC without buffering them in the camera. The PC can be removed once recording has been started in "Wait for trigger

signal" mode. The camera operates automatically and waits for the trigger condition to occur. Recorded sequences are stored in the internal memory of the respective camera and can be transmitted to the FCT software once a connection has been re-established with a PC. The sequences are archived and can be analysed on the PC.

Compact Vision System SBOC-M

Peripherals overview

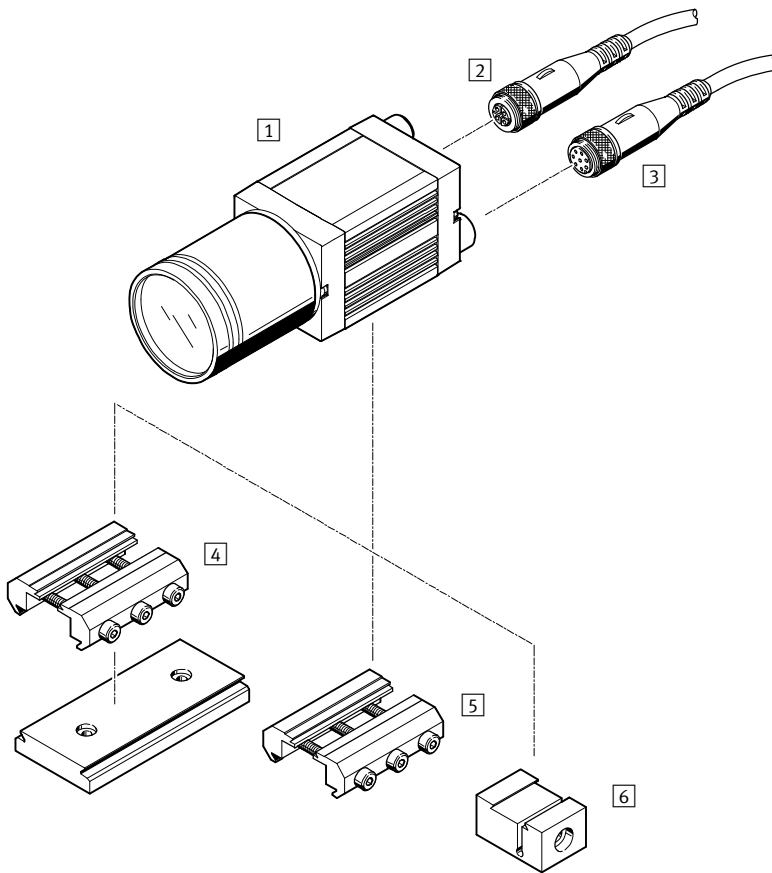

Accessories	Brief description	→ Page/Internet
Compact Vision System		
1 SBOC-M-R1B-H	For standard lens with C mount connection	6
Cable with socket		
2 SBOA-K30E-M12S	Ethernet diagnostic cable	12
3 SIM-M12-8GD-...-PU	For supplying the operating voltage	
Lens		
- SASF-C-L-F...	Focal distance 6 ... 35 mm	11
Mounting components		
4 Adapter kit SBOA-HMSV-39	With screw-on adapter plate	8
5 Adapter kit SBOA-HMSV-40	Without screw-on adapter plate	
6 Adapter kit SBOA-HMSV-41	With female thread G¼ for mounting on commercially available tripods	
- Adapter SBOL-C-5	5 mm spacer ring (CS mount to C mount)	9

Compact Vision System SBOC-M

Type codes

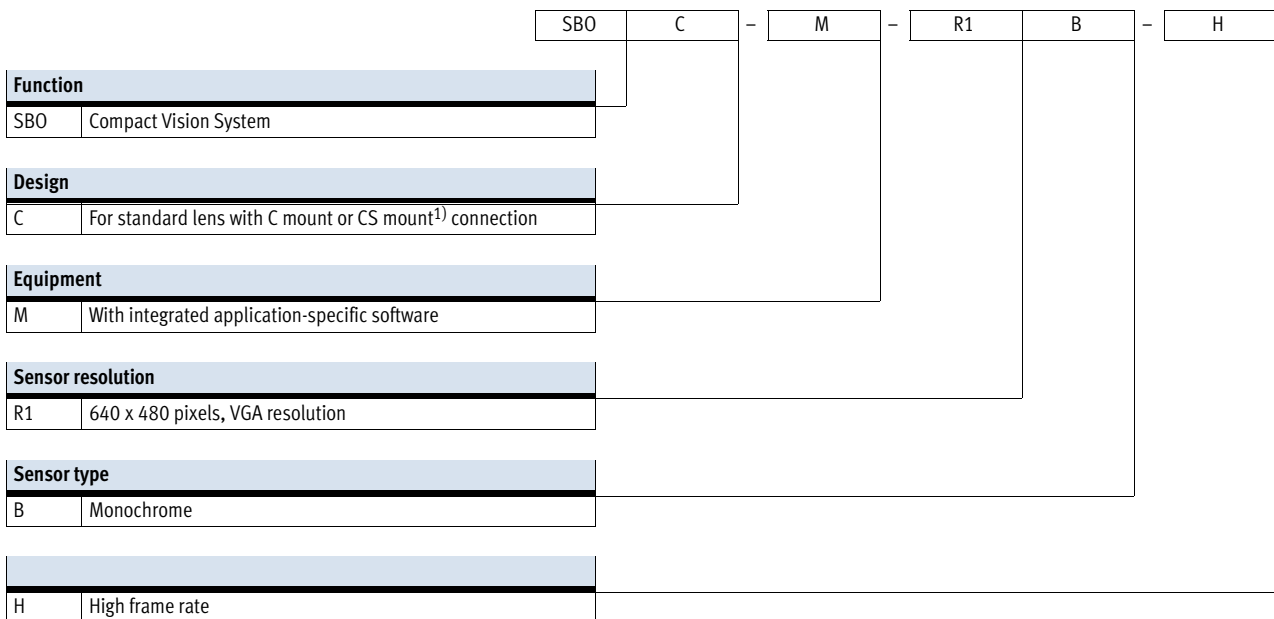

1) CS mount without protective tube.

Compact Vision System SBOC-M

FESTO

Technical data

-  - Voltage
24 V DC

-  - Temperature range
-10 ... +50 °C



General technical data		
Type		SBOC-M-R1B-H
Sensor resolution	[pixels]	640 x 480 (VGA)
Length	[mm]	139.4
Width	[mm]	45
Height	[mm]	45
Exposure time	[µs]	1 ... 1,000,000
Frame rate (full image)	[fps]	241
Sensor type		Monochrome
Lens mounting		CS mount (C mount with lens protective tube)
Operating distance	[mm]	Dependent on the lens selected
Field of vision	[mm]	Dependent on the lens selected

Electrical data		
Nominal operating voltage	[V DC]	24
Permissible voltage fluctuations	[%]	±10
Current consumption with load-free outputs	[mA]	120
Max. residual current	[A]	1.5 at the 24 V outputs
Protection class		IP65, IP67
Ethernet interface		
Bus interface		IEEE802.3U (100BaseT)
Connection technology		Plug M12
Transmission speed	[Mbps]	100
Supported protocols		TCP/IP

Operating and environmental conditions		
Ambient temperature	[°C]	-10 ... +50
Storage temperature	[°C]	-10 ... +60
Ambient conditions		Screened from extreme external light sources Cleanest possible ambient air
CE mark (see declaration of conformity) ¹⁾		To EU EMC Directive
Certification		c UL us - Recognized (OL) C-Tick

1) For information about the applicability of the component see the manufacturer's EC declaration of conformity at: www.festo.com/sp → User documentation.
If the component is subject to restrictions on usage in residential, office or commercial environments or small businesses, further measures to reduce the emitted interference may be necessary.

Compact Vision System SBOC-M

Technical data

Materials	
Housing	Anodised aluminium
Cap	Acrylic butadiene styrene, glass fibre reinforced
Note on materials	Free of copper and PTFE
	RoHS-compliant

Weight [g]	
Lens mounting	CS mount (C mount with lens protective tube)
Type	SBOC-M-R1B-H
Compact Vision System	182

Dimensions Download CAD data → www.festo.com

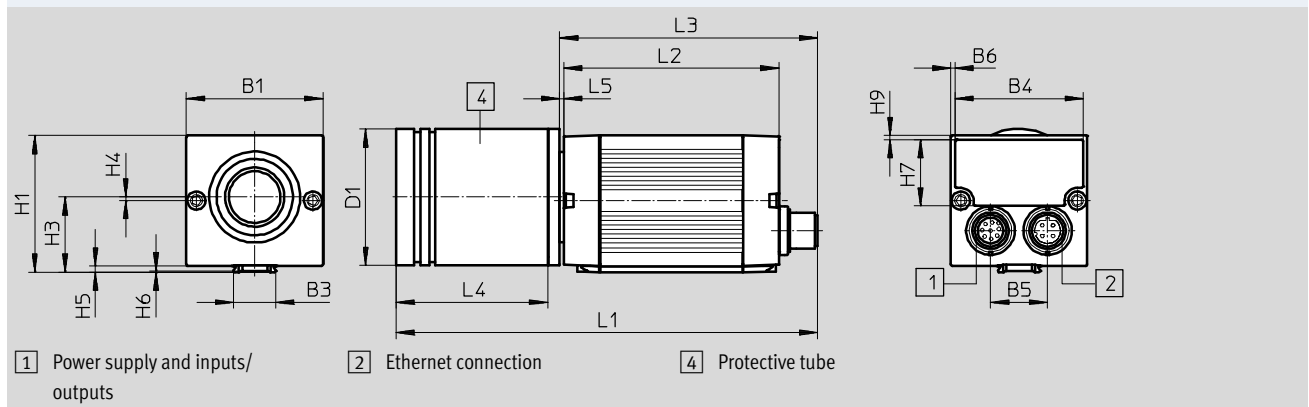

Type	B1	B3	B4	B5	B6	D1	H1	H3	H4	H5	H6	H7	H8	H9	L1	L2	L3	L4	L5
SBOC-M-R1B-H	45	13.91	42.2	18.8	1.4	45	45	24.65	1.15	2	0.3	21.8	-	1.4	139	71	85	50	1.3

Ordering data			
	Sensor type	Part No.	Type
640 x 480 pixels (VGA)			
CS mount (C mount with lens protective tube)	Monochrome	574642	SBOC-M-R1B-H

Compact Vision System SBOC-M

Accessories



Adapter kit

SBOA-HMSV-39

with screw-on adapter plate

Material:

Anodised wrought aluminium alloy

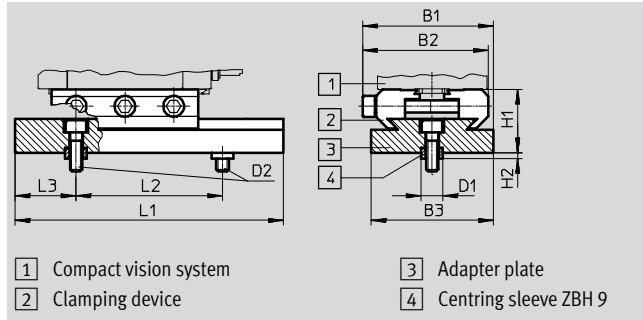

Ordering data												Part No.	Type	
Type	B1	B2	B3	D1 ∅	D2	H1	H2	L1	L2	L3				
SBOA-HMSV-39	53.5	51.5	50	9	M5x16	26	2	110	60	25			541599	SBOA-HMSV-39

Adapter kit

SBOA-HMSV-40

without screw-on adapter plate

Material:

Anodised wrought aluminium alloy

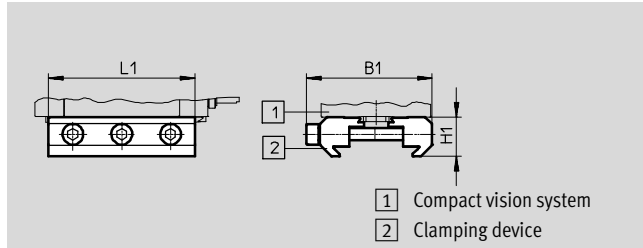

Ordering data					Part No.	Type
Type	B1	H1	L1			
SBOA-HMSV-40	51.5	16	60		541600	SBOA-HMSV-40

Compact Vision System SBOC-M

Accessories

FESTO

Adapter kit

SBOA-HMSV-41

with female thread G $\frac{1}{4}$ for mounting on commercially available tripods

Material:

Anodised wrought aluminium alloy

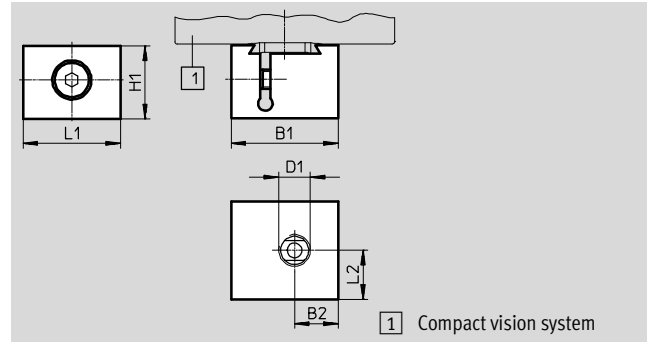

Ordering data							
Type	B1	B2	D1 Ø	H1	L1	L2	Part No. Type
SBOA-HMSV-41	22	9	$\frac{1}{4}$ -20 UNC	15	20	10	542140 SBOA-HMSV-41

Adapter SBOL-C-5

5 mm spacer ring
(CS mount to C mount)

Material:

Anodised wrought aluminium alloy

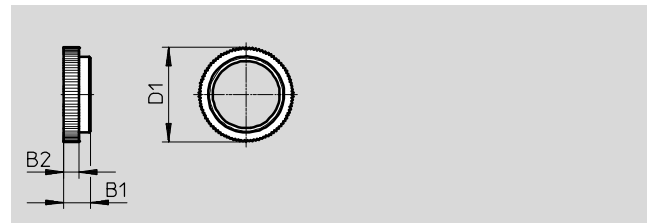

Ordering data				
Type	B1	B2	D1 Ø	Part No. Type
SBOL-C-5	8.8	5	31	541601 SBOL-C-5

Compact Vision System SBOC-M

Accessories

FESTO

Vision system

SBOA-M-SYSTAINER-110V

Systainer with Compact Vision System SBOC-M-R1B and accessories for mains voltage 110 V



Note on materials:

Contains PWIS (paint-wetting impairment substances)

Ordering data			
Contents	Pieces	Part No.	Type
Compact Vision System SBOC-M-R1B, without protective tube	1	572909	SBOA-M-SYSTAINER-110V
Zoom lens, focal depth 10 ... 40 mm, CS mount	1		
Adapter kit SBOA-HMSV-41 for mounting on commercially available tripods	1		
Tripod for camera and lighting	2		
Ethernet diagnostic cable SBOA-K30E-M12S	1		
Crossover patch cable	1		
Coupler, RJ45	1		
System light incl. plug for USA, 850 W/75 h, with tilting head and four-way folding frame	1		
Spare light bulb, U-shaped halogen lamp, 850 W/110 V	1		
Trigger with pushbutton and extension cable	1		
Power supply for camera/power supply unit with plug-in adapter for USA	1		
CD-ROM with FCT configuration package and documentation	1		

Vision system

SBOA-M-SYSTAINER

Systainer with Compact Vision System SBOC-M-R1B and accessories for mains voltage 110 V ... 230 V



Ordering data			
Contents	Pieces	Part No.	Type
Compact Vision System SBOC-M-R1B, without protective tube	1	575980	SBOA-MSY-R1B-H
Illuminated LED 84 W / 9 000 Lumen	1		
Adapter for light	1		
Adapter	1		
Power supply unit	1		
Tripod	2		
Lens 4 ... 48 mm	1		
Trigger	1		
Coupler, RJ45	1		
Crossover patch cable	1		
Extension cable Sub-D	1		
Adapter kit SBOA-HMSV-41	1		
Cable SBOA-K30E-M12S	1		
Brief overview GDSC-SBOC-Z6	1		
CD-ROM documentation GDSC-E-SBOC-D2	1		
Intermediate ring ZW-R5,0	1		
Protective cap M12, pin	2		

Compact Vision System SBOC-M

Accessories



Lens SASF-C-L-F6

Focal depth 6 mm

Note on materials:
Contains PWIS (paint-wetting
impairment substances)
RoHS-compliant

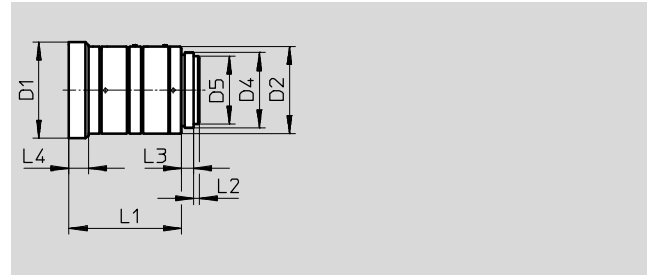

Lens SASF-C-L-F16

Focal depth 16 mm

Note on materials:
Contains PWIS (paint-wetting
impairment substances)
RoHS-compliant

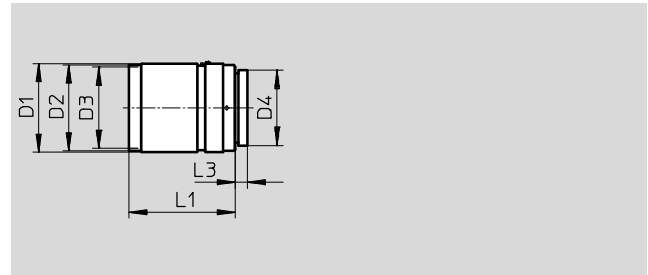

Lens SASF-C-L-F12/25/35

Focal depth 12/25/35 mm

Note on materials:
Contains PWIS (paint-wetting
impairment substances)
RoHS-compliant

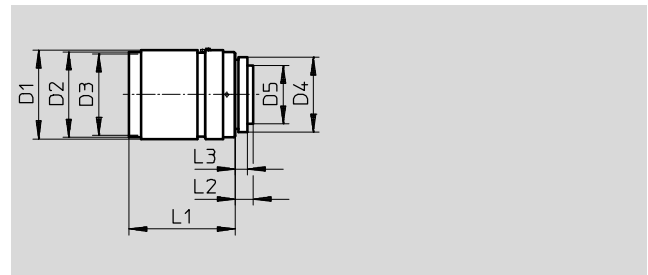



Dimensions									
Type	D1 Ø	D2 Ø	D3 Ø	D4	D5 Ø	L1	L2	L3	L4
SASF-C-L-F6	32	29	–	1-32UN	22.5	37.5	1.9	4	6.5
SASF-C-L-F16	29.5	28.5	27, P=0.5	1-32UN-2A	–	33.2	–	4	–
SASF-C-L-F12	29.5	28.5	27, P=0.5	1-32UN-2A	16.5	28.5	7.1	4	–
SASF-C-L-F25					32	6.9			
SASF-C-L-F35					19.5	35.4	6		

Ordering data – Lenses				Technical data → Internet: sasf-c	
	Brief description	Operating distance [mm]	Focal depth [mm]	Part No.	Type
	C mount for Compact Vision System with sensor resolution R1 and R3	≥200	6	572910	SASF-C-L-F6
	C mount for Compact Vision System with sensor resolution R1 and R3	≥250	12	572911	SASF-C-L-F12
	C mount for Compact Vision System with sensor resolution R1, R2 and R3	≥250	16	572912	SASF-C-L-F16
			25	572913	SASF-C-L-F25
			35	572914	SASF-C-L-F35

Compact Vision System SBOC-M

Accessories

FESTO

Ordering data – Cable M12x1					Technical data → Internet: sim, sboa	
	Assembly	Use	Connection	Cable length [m]	Part No.	Type
Straight socket						
	Union nut M12x1	Operating voltage supply	8-pin	2	525616	SIM-M12-8GD-2-PU
				5	525618	SIM-M12-8GD-5-PU
	Union nut M12x1	Ethernet diagnostic cable	4-pin, d-coded	3	542139	SBOA-K30E-M12S

Ordering data – Software			
	Brief description	Language	Part No. Type
	Operator package, information software	–	8001253 GDCS-EPCP-SBOC-D2
	Description	German	8001258 GDCS-SBOC-DE
		English	8001260 GDCS-SBOC-EN

Product Range and Company Overview

A Complete Suite and Company Overview

Our experienced engineers provide complete support at every stage of your development process, including: conceptualization, analysis, engineering, design, assembly, documentation, validation, and production.



Custom Automation Components
Complete custom engineered solutions

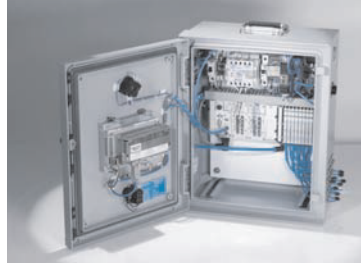

Custom Control Cabinets
Comprehensive engineering support and on-site services



Complete Systems
Shipment, stocking and storage services

The Broadest Range of Automation Components

With a comprehensive line of more than 30,000 automation components, Festo is capable of solving the most complex automation requirements.



Electromechanical
Electromechanical actuators, motors, controllers & drivers



Pneumatics
Pneumatic linear and rotary actuators, valves, and air supply



PLCs and I/O Devices
PLC's, operator interfaces, sensors and I/O devices

Supporting Advanced Automation... As No One Else Can!

Festo is a leading global manufacturer of pneumatic and electromechanical systems, components and controls for industrial automation, with more than 16,000 employees in 60 national headquarters serving more than 180 countries. For more than 80 years, Festo has continuously elevated the state of manufacturing with innovations and optimized motion control solutions that deliver higher performing, more profitable automated manufacturing and processing equipment. Our dedication to the advancement of automation extends beyond technology to the education and development of current and future automation and robotics designers with simulation tools, teaching programs, and on-site services.

Quality Assurance, ISO 9001 and ISO 14001 Certifications

Festo Corporation is committed to supply all Festo products and services that will meet or exceed our customers' requirements in product quality, delivery, customer service and satisfaction.

To meet this commitment, we strive to ensure a consistent, integrated, and systematic approach to management that will meet or exceed the requirements of the ISO 9001 standard for Quality Management and the ISO 14001 standard for Environmental Management.



© Copyright 2013, Festo Corporation. While every effort is made to ensure that all dimensions and specifications are correct, Festo cannot guarantee that publications are completely free of any error, in particular typing or printing errors. Accordingly, Festo cannot be held responsible for the same. For Liability and Warranty conditions, refer to our "Terms and Conditions of Sale", available from your local Festo office. All rights reserved. No part of this publication may be reproduced, distributed, or transmitted in any form or by any means, electronic, mechanical, photocopying or otherwise, without the prior written permission of Festo. All technical data subject to change according to technical update.



Printed on recycled paper at New Horizon Graphic, Inc., FSC certified as an environmental friendly printing plant.

Festo North America

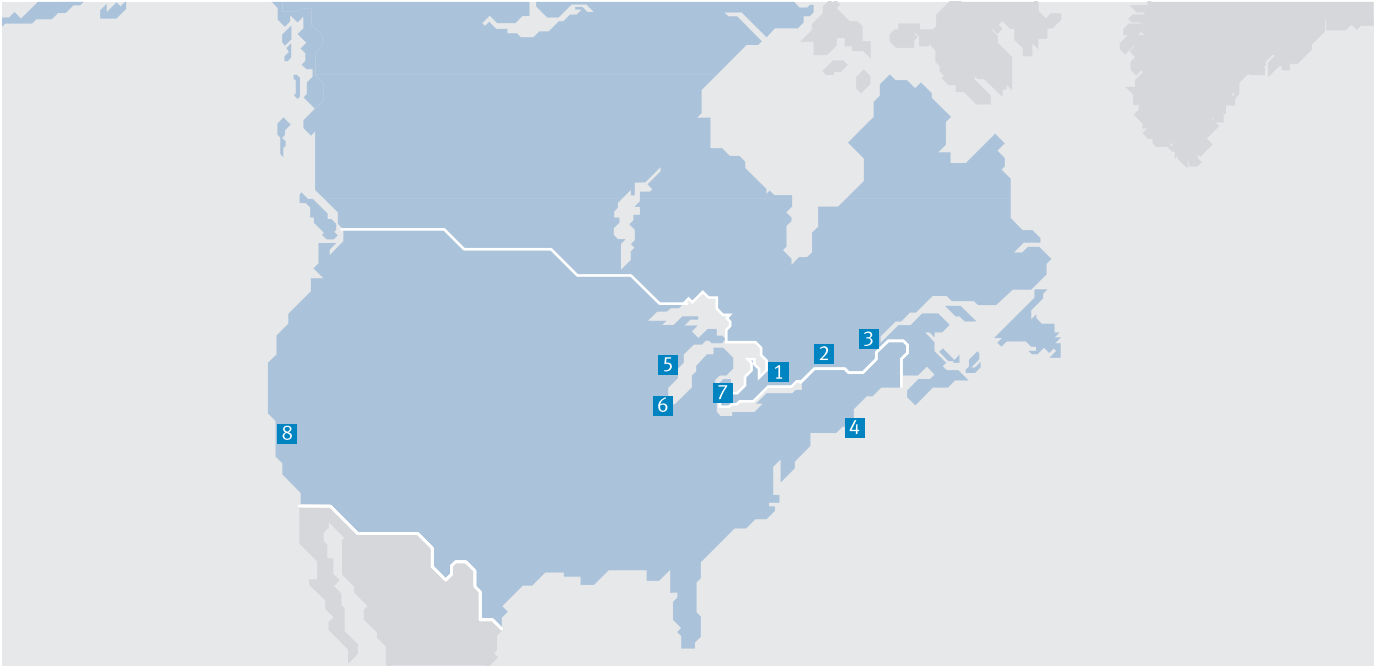

**1 Festo Canada
Headquarters
Festo Inc.**
5300 Explorer Drive
Mississauga, ON
L4W 5G4

2 Montréal
5600, Trans-Canada
Pointe-Claire, QC
H9R 1B6

3 Québec City
2930, rue Watt#117
Québec, QC
G1X 4G3



**4 Festo United States
Headquarters
Festo Corporation**
395 Moreland Road
Hauppauge, NY
11788

5 Appleton
North 922 Tower View Drive, Suite N
Greenville, WI
54942

7 Detroit
1441 West Long Lake Road
Troy, MI
48098

6 Chicago
85 W Algonquin - Suite 340
Arlington Heights, IL
60005

8 Silicon Valley
4935 Southfront Road, Suite F
Livermore, CA
94550

Festo Regional Contact Center

Canadian Customers

Commercial Support:
Tel: 1 877 GO FESTO (1 877 463 3786)
Fax: 1 877 FX FESTO (1 877 393 3786)
Email: festo.canada@ca.festo.com

Technical Support:
Tel: 1 866 GO FESTO (1 866 463 3786)
Fax: 1 877 FX FESTO (1 877 393 3786)
Email: technical.support@ca.festo.com

USA Customers

Commercial Support:
Tel: 1 800 99 FESTO (1 800 993 3786)
Fax: 1 800 96 FESTO (1 800 963 3786)
Email: customer.service@us.festo.com

Technical Support:
Tel: 1 866 GO FESTO (1 866 463 3786)
Fax: 1 800 96 FESTO (1 800 963 3786)
Email: product.support@us.festo.com