



- Co-ordinated with Festo's cylinder range
- Versatile combinations
- Sturdy and functional
- Stainless steel variants

Piston rod attachments

Peripherals overview



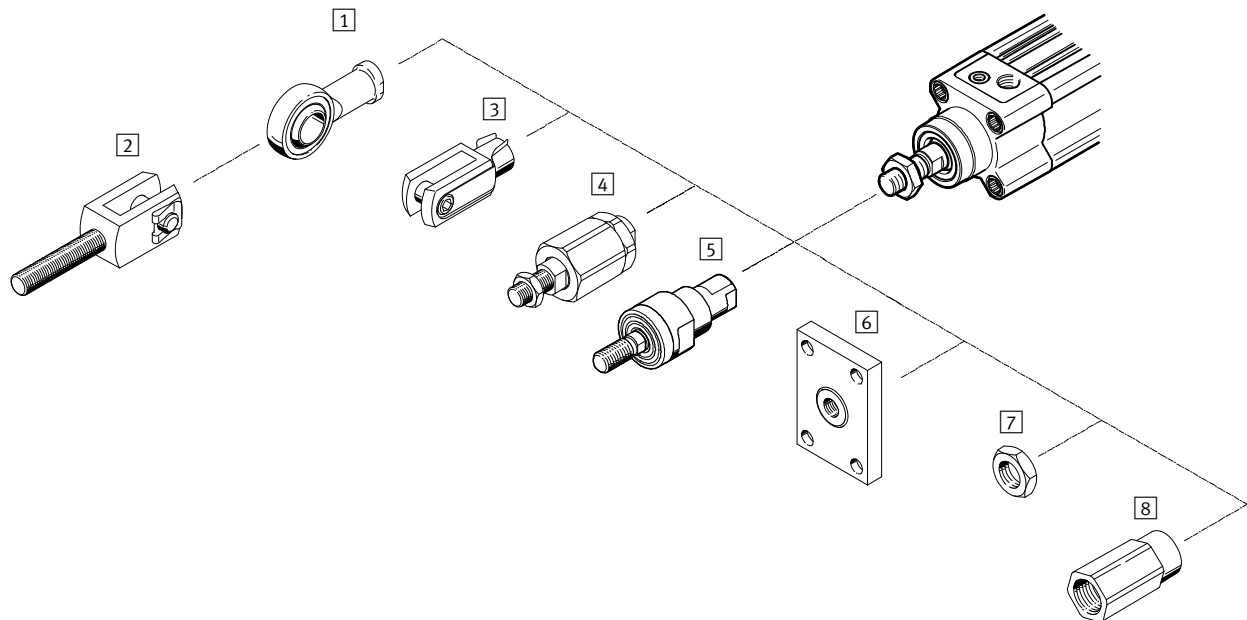

FESTO



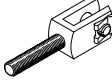

Mounting attachments and accessories		Description
1	Rod eye SGS	Rod eyes are maintenance-free due to the combination of steel and PTFE-bronze material in the swivel bearing. Corresponds to ISO 12240-4 dimensional series K.
	Rod eye CRSGS	Corrosion and acid-resistant design. Corresponds to ISO 12240-4 dimensional series K.
2	Rod clevis SGA	Rod clevises are used in combination with the rod eye SGS for spherical connection of cylinders.
3	Rod clevis SG	This rod clevis is fitted to the threaded end of the piston rod and permits a swivelling movement of the cylinder in one plane. Corresponds to ISO 8140 or DIN 71752.
	Rod clevis CRSG	Corrosion and acid-resistant design. Corresponds to ISO 8140 or DIN 71752.
4	Self-aligning rod coupler FK	Rod couplers link the piston rod end of all cylinder types to the machine parts to be moved. This compensates for radial and angular deviations (misalignment).
5	Self-aligning rod coupler CRFK	Corrosion and acid-resistant design.
6	Coupling piece KSG	Coupling pieces link the piston rod end of all cylinder types to the machine parts to be moved. They compensate radial misalignments up to ± 1 mm.
	Coupling piece KSZ	For cylinders with non-rotating piston rods. With this coupling piece, a cylinder can be connected with positional stability to the component being moved in order to compensate for radial deviation.
7	Hex nut MSK	Based on and/or corresponds to ISO 8675.
8	Adapter AD	Specially for through, hollow piston rods, e.g. for connecting vacuum generators.

Piston rod attachments

Product range overview

Piston rod attachments						
Piston rod thread		Rod eye		Rod clevis		
Male	Female	SGS-...	CRSGS-...	SGA-... ¹⁾	SG-...	CRSG-...
						
M4		■	-	-	■	-
M6		■	■	-	■	■
M8		■	■	-	■	■
M10		■	-	-	■	-
M10x1.25		■	■	■	■	■
M12		■	-	■	■	-
M12x1.25		■	■	■	■	■
M16		■	-	■	■	-
M16x1.5		■	■	■	■	■
M20x1.5		■	■	■	■	■
M27x2		■	■	■	■	■
M36x2		■	-	-	■	-
M42x2		■	-	-	■	-
M48x2		■	-	-	■	-
Technical data → Page/Internet		4	5	6	7	9

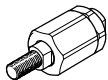
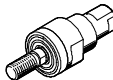
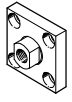
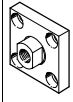
1) Only to be attached to the piston rod in conjunction with the rod eye SGS.

Piston rod attachments							
Piston rod thread		Self-aligning rod coupler		Coupling piece		Hex nut	Adapter
Male	Female	FK-...	CRFK-...	KSG-...	KSZ-...	MSK-...	AD-...
							
M4		■	-	-	-	-	-
M6		■	-	-	■	-	■
M8		■	-	-	■	-	■
M10		■	-	-	-	-	-
M10x1.25		■	■	■	■	■	■
M12		■	-	-	-	-	-
M12x1.25		■	■	■	■	■	■
M16		■	-	-	-	-	-
M16x1.5		■	■	■	■	■	-
M20x1.5		■	■	■	■	-	-
M27x2		■	-	■	-	-	-
M36x2		■	-	-	-	-	-
M42x2		-	-	-	-	-	-
M48x2		-	-	-	-	-	-
	M4	■	-	-	-	-	-
	M5	■	-	-	-	-	-
	M6	■	-	-	-	-	-
	M8	■	-	-	-	-	-
	M10	■	-	-	-	-	-
	M12	■	-	-	-	-	-
Technical data → Page/Internet		10	11	12	13	14	15

Rod eyes SGS

Technical data

FESTO

Rod eye SGS

Scope of delivery:

1 rod eye, 1 hex nut to DIN 439

Material:

Galvanised steel

RoHS-compliant

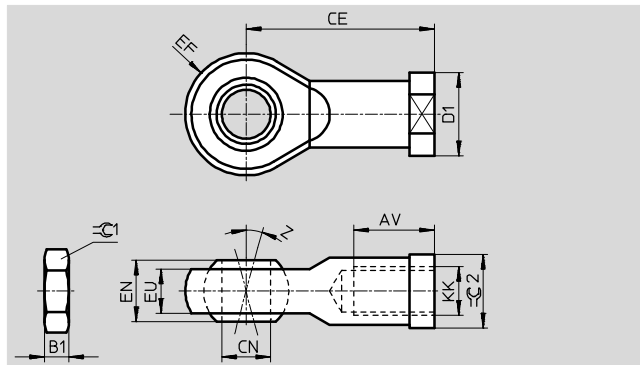

Dimensions and ordering data								
KK	AV	B1	CE	CN Ø H7	D1 Ø	EF ±0.5	EN	EU
M4	10 -2	2.2	27	5	11	9	8	6
M6	12 -2	3.2	30	6	13	10	9	6.8
M8	16 -2	4	36	8	16	12	12	9
M10	20 -2	5	43	10	19	14	14	10.5
M10x1.25								
M12	22 -2	6	50	12	22	16	16	12
M12x1.25								
M16	28 -2	8	64	16	27	21	21	15
M16x1.5								
M20x1.5	33 -2	10	77	20	34	25	25	18
M27x2	51 -2	13.5	110	30	50	35	37	25
M36x2	56 +2	18	125	35	58	40	43	28
M42x2	60 +2	21	142	40	65	45	49	33
M48x2	65 +2	24	160	50	75	58	60	45

KK	Z [°]	≈C1	≈C2	ISO 12240-4 dimensional series K	CRC ¹⁾	Weight [g]	Part No.	Type
M4	13	7	9	–	2	21	9253	SGS-M4
M6	13	10	11	■	2	29	9254	SGS-M6
M8	13	13	14	■	2	53	9255	SGS-M8
M10	13	17	17	■	2	88	9256	SGS-M10
M10x1.25				–	2	87	9261	SGS-M10x1,25
M12	13	19	19	■	2	131	9257	SGS-M12
M12x1.25				–	2	129	9262	SGS-M12x1,25
M16	15	24	22	■	2	263	9258	SGS-M16
M16x1.5				–	2	259	9263	SGS-M16x1,5
M20x1.5	15	30	30	■	2	464	9264	SGS-M20x1,5
M27x2	15	41	41	–	2	1333	10774	SGS-M27x2
M36x2	15	55	50	■	2	2084	10775	SGS-M36x2
M42x2	15	65	55	■	2	3132	10776	SGS-M42x2
M48x2	12	75	65	■	2	5498	10777	SGS-M48x2

1) Corrosion resistance class CRC 2 to Festo standard FN 940070

Moderate corrosion stress. Indoor applications in which condensation may occur. External visible parts with primarily decorative requirements for the surface and which are in direct contact with the ambient atmosphere typical for industrial applications.

Rod eyes CRSGS, stainless steel

Technical data

FESTO

Rod eye CRSGS

Scope of delivery:

1 rod eye, 1 hex nut to DIN 439

Material:

High-alloy steel

RoHS-compliant

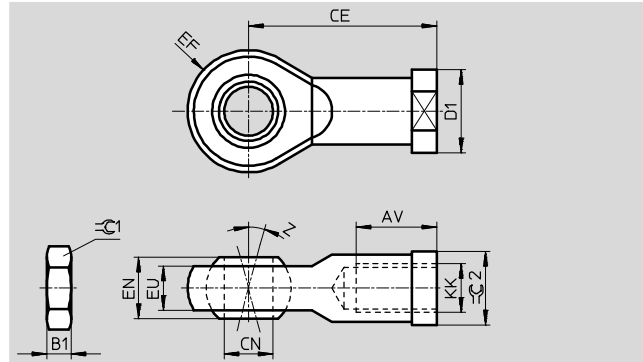

Dimensions and ordering data								
KK	AV	B1	CE	CN ∅ H7	D1 ∅	EF ±0.5	EN	EU
M6	12	3.2	30	6	13	10	9	6.8
M8	16	4	36	8	16	12	12	9
M10x1.25	20	5	43	10	19	14	14	10.5
M12x1.25	22	6	50	12	22	16	16	12
M16x1.5	28	8	64	16	27	21	21	15
M20x1.5	33	10	77	20	34	25	25	18
M27x2	51	13.5	110	30	50	35	37	25

KK	Z [°]	≈C1	≈C2	ISO 12240-4 dimensional series K	CRC ¹⁾	Weight [g]	Part No.	Type
M6	13	10	11	■	4	29	195580	CRSGS-M6
M8	13	13	14	■	4	53	195581	CRSGS-M8
M10x1.25	13	17	17	–	4	87	195582	CRSGS-M10x1,25
M12x1.25	13	19	19	–	4	129	195583	CRSGS-M12x1,25
M16x1.5	15	24	22	–	4	259	195584	CRSGS-M16x1,5
M20x1.5	15	30	30	■	4	464	195585	CRSGS-M20x1,5
M27x2	15	41	41	–	4	1333	195586	CRSGS-M27x2

1) Corrosion resistance class CRC 4 to Festo standard FN 940070

Particularly high corrosion stress. Outdoor exposure under extreme corrosive conditions. Parts exposed to aggressive media, for instance in the chemical or food industries. These applications may need to be supported by special tests (→ also FN 940082) using appropriate media.

Rod clevises SGA

Technical data



Rod clevis SGA

Scope of delivery:
1 rod clevis, 1 pivot pin
and 1 retaining clip

Material:
Galvanised steel
Free of copper and PTFE
RoHS-compliant

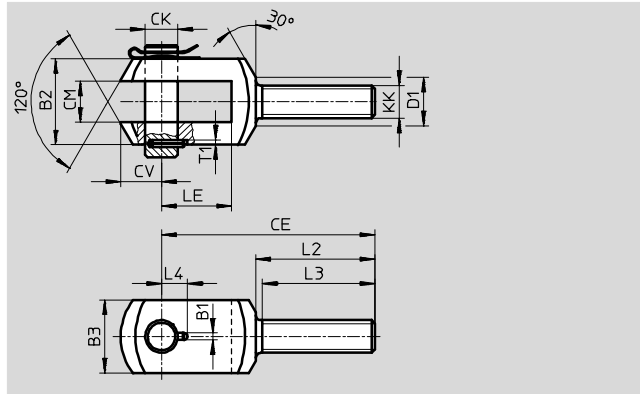

The rod clevis SGA [1] is used in combination with the rod eye SGS [2] (→ 4) for spherical mounting of cylinders.

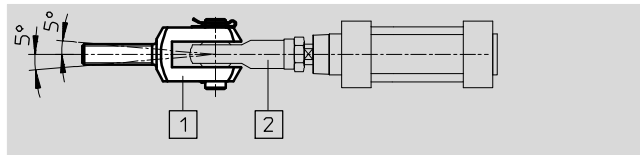

Dimensions and ordering data								
KK	B1	B2	B3	CE	CK	CM	CV	D1
		d12			∅ F7/h9	B12		∅
M10x1.25	3.3	28	20	78	10	14	12	18
M12	4.3	30	25	92	12	16	16	19
M12x1.25								
M16	4.3	40	35	108	16	21	21	24
M16x1.5								
M20x1.5	4.3	50	40	131	20	25	25	30
M27x2	6.3	67	60	168	30	37	32	38
M36x2	6.3	78	70	211	35	43	39	48

KK	L2	L3	L4	LE	T1	CRC ¹⁾	Weight	Part No.	Type
							[g]		
M10x1.25	53	50	11	20	3	1	129	32954	SGA-M10x1,25
M12	58	55	12	26	3	1	222	6523	SGA-M12
M12x1.25									
M16	65	62	14	31	3	1	512	6524	SGA-M16
M16x1.5									
M20x1.5	73	69	16	43	3	1	954	10769	SGA-M20x1,5
M27x2	98	92	24	54	5	1	2189	10770	SGA-M27x2
M36x2	121	115	26.5	72	5	1	3938	10771	SGA-M36x2

1) Corrosion resistance class CRC 1 to Festo standard FN 940070
Low corrosion stress. For dry indoor applications or transport and storage protection. Also applies to parts behind covers, in the non-visible interior area, and parts which are covered in the application (e.g. drive trunnions).

Rod clevises SG

Technical data



Rod clevis SG

Scope of delivery:

1 rod clevis, 1 hinged spring pin,
1 hex nut (M4: DIN 934, M6 ... M16:
DIN 439)

Material:

Galvanised steel
Free of copper and PTFE
RoHS-compliant

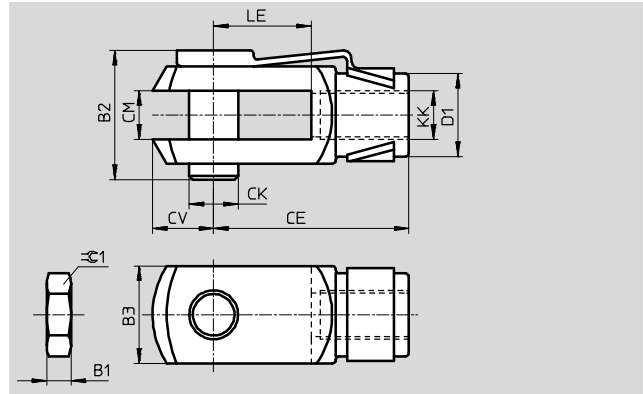
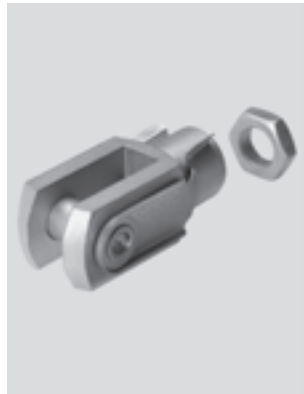

Dimensions and ordering data								
KK	B1	B2	B3	CE	CK ∅	CM	CV	D1 ∅
M4	3.2	11.1	8	16±0.3	4h11	4B13	5	8
M6	3.2	16.2	12	24±0.3	6h11	6B13	7	10
M8	4	21.6	16	32±0.4	8h11	8B13	10	14
M10	5	26	20	40±0.4	10h11	10B13	12	18
M10x1.25								
M12	6	31.1	24	48±0.4	12h11	12+0.7/+0.15	14	20
M12x1.25								
M16	8	39.5	32	64±0.4	16h11	16+0.7/+0.15	19	26
M16x1.5								

KK	LE ±0.5	≈C1	ISO 8140	DIN 71752	CRC ¹⁾	Weight [g]	Part No.	Type
M4	8	7	–	■	1	10	6532	SG-M4
M6	12	10	■	■	1	25	3110	SG-M6
M8	16	13	■	■	1	55	3111	SG-M8
M10	20	17	–	■	1	105	2674	SG-M10
M10x1.25			■	■	1	105	6144	SG-M10x1,25
M12	24	19	–	■	1	165	2675	SG-M12
M12x1.25			■	■	1	165	6145	SG-M12x1,25
M16	32	24	–	■	1	385	2676	SG-M16
M16x1.5			■	■	1	385	6146	SG-M16x1,5

1) Corrosion resistance class CRC 1 to Festo standard FN 940070

Low corrosion stress. For dry indoor applications or transport and storage protection. Also applies to parts behind covers, in the non-visible interior area, and parts which are covered in the application (e.g. drive trunnions).

Rod clevises SG

Technical data

FESTO

Rod clevis SG

Scope of delivery:

1 rod clevis, 1 bolt, 1 retaining ring
1 hex nut (DIN 439)

Material:

Galvanised steel
Free of copper and PTFE
RoHS-compliant

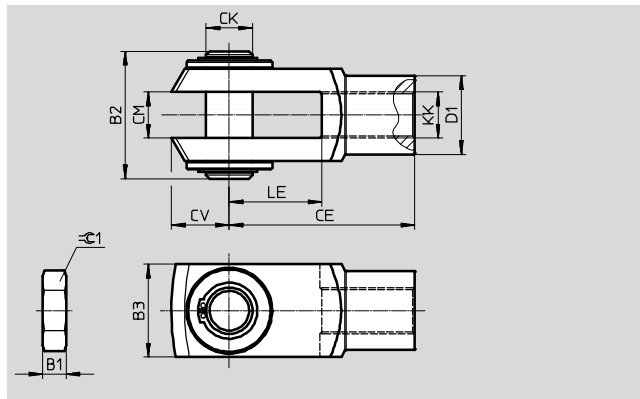
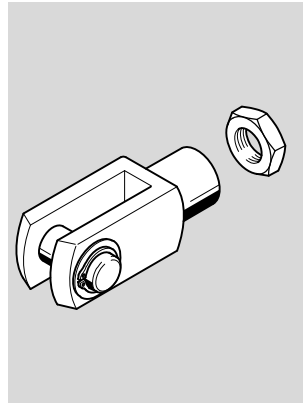

Dimensions and ordering data								
KK	B1	B2	B3	CE	CK ∅	CM	CV	D1 ∅
M20x1.5	10	55	40	80±0.4	20e8	20+0.7/+0.15	25	34
M27x2	13.5	73	55	110±0.4	30e8	30+0.7/+0.15	38	48
M36x2	18	93	70	144±0.4	35e8	35+0.7/+0.15	44	60
M42x2	21	111	85	168±0.4	40e8	40+0.7/+0.15	64	70
M48x2	24	121.5	90	192±0.4	50e8	50+0.7/+0.15	73	80

KK	LE ±0.5	≈C1	ISO 8140	CRC ¹⁾	Weight [g]	Part No.	Type
M20x1.5	40	30	■	1	785	6147	SG-M20x1,5
M27x2	54	41	■	1	2145	14987	SG-M27x2-B
M36x2	72	55	■	1	4220	9581	SG-M36x2
M42x2	84	65	■	1	7520	9582	SG-M42x2
M48x2	96	75	■	1	10030	9583	SG-M48x2

1) Corrosion resistance class CRC 1 to Festo standard FN 940070

Low corrosion stress. For dry indoor applications or transport and storage protection. Also applies to parts behind covers, in the non-visible interior area, and parts which are covered in the application (e.g. drive trunnions).

Rod clevises CRSG, stainless steel

Technical data

Rod clevis CRSG

Scope of delivery:

1 rod clevis, 1 pivot pin,
1 hex nut to DIN 439

Material:

High-alloy steel

Free of copper and PTFE

RoHS-compliant

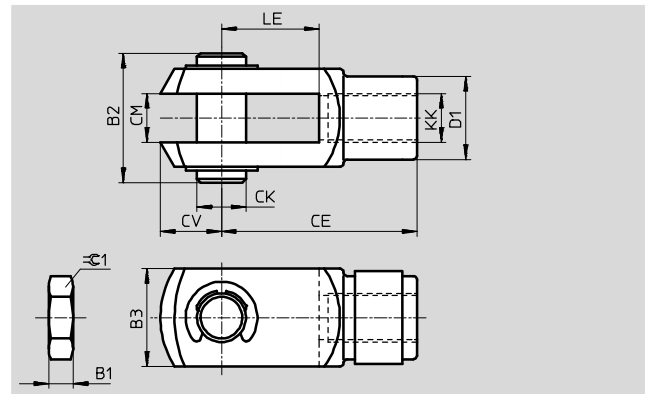

Dimensions and ordering data								
KK	B1	B2	B3	CE	CK	CM	CV	D1
			h11		∅ H9/e8			∅ ±0.3
M6	3.2	19	12	24±0.3	6	6B13	7	10
M8	4	24	16	32±0.4	8	8B13	10	14
M10x1.25	5	27	20	40±0.4	10	10B13	12	18
M12x1.25	6	33	24	48±0.4	12	12+0.7/+0.15	14	20
M16x1.5	8	43	32	64±0.4	16	16+0.7/+0.15	19	26
M20x1.5	10	53	40	80±0.4	20	20+0.7/+0.15	25	34
M27x2	13.5	70	55	110±0.4	30	30+0.7/+0.15	38	48

KK	LE	≈C1	ISO 8140	DIN 71752	CRC ¹⁾	Weight	Part No.	Type
	±0.5					[g]		
M6	12	10	■	■	4	25	13567	CRSG-M6
M8	16	13	■	■	4	55	13568	CRSG-M8
M10x1.25	20	17	■	■	4	110	13569	CRSG-M10x1,25
M12x1.25	24	19	■	■	4	180	13570	CRSG-M12x1,25
M16x1.5	32	24	■	■	4	395	13571	CRSG-M16x1,5
M20x1.5	40	30	■	-	4	800	13572	CRSG-M20x1,5
M27x2	54	41	■	-	4	1900	185361	CRSG-M27x2

1) Corrosion resistance class CRC 4 to Festo standard FN 940070
Particularly high corrosion stress. Outdoor exposure under extreme corrosive conditions. Parts exposed to aggressive media, for instance in the chemical or food industries. These applications may need to be supported by special tests (→ also FN 940082) using appropriate media.

Self-aligning rod couplers FK

Technical data



Self-aligning rod coupler FK

Scope of delivery:

- 1 self-aligning rod coupler,
- 1 hex nut to DIN 439

Material:

- Galvanised steel
- Free of copper and PTFE
- RoHS-compliant

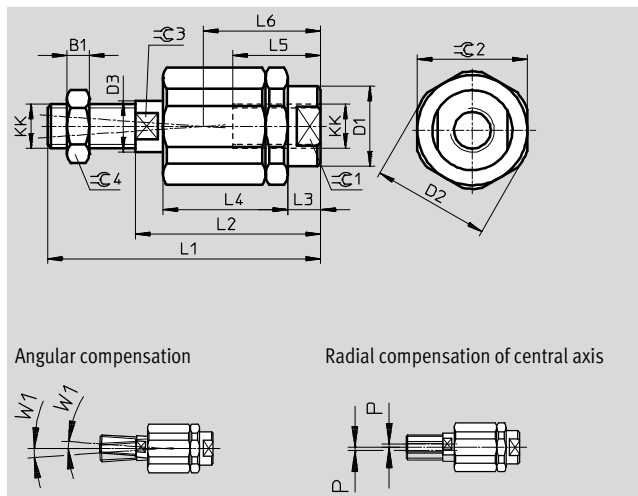

Dimensions and ordering data													
KK	B1	D1 ∅	D2 ∅	D3 ∅	L1	L2	L3	L4	L5	L6	W1 [°]	≈C1	≈C2
M4	2.2	–	–	3.8	33	24	4.5	16.5	12.5	16	4	11	11
M5	2.7	8.5	14.5	5.8	38.5	25	4.4	17.5	11.5	15.7	4	7	13
M6	3.2	8.5	14.5	5.8	37	25	4.4	17.5	11.5	15.7	4	7	13
M8	4	12.5	19	7.8	49	34	6	23.5	14	20.5	4	10	17
M10	5	21.4	32.5	13.8	67.5	49.5	9	34	23	31	4	19	30
M10x1.25					69.5						4		
M12	6	21.4	32.5	13.8	70.5	49.5	9	34	23	31	4	19	30
M12x1.25					74.5						10		
M16	8	33.8	45	22	97	71	10	53	32	44.5	4	30	41
M16x1.5					103						4		
M20x1.5	10	33.8	45	22	120	80	19	53	41	53.5	4	30	41
M27x2	13.5	62	62	28	157	103	12.2	79	42	62.5	4	55	55
M36x2	18	80	80	38	251	179	22	136	78	110	4	75	75

KK	≈C3	≈C4	Tensile and compressive load max. [N]	Axial play [mm]	Radial deviation P [mm]	CRC ¹⁾	Weight [g]	Part No.	Type
M4	3.2	7	750	0.04 ... 0.2	±0.5	2	15	6528	FK-M4
M5	5	8	1200	0.04 ... 0.2	±0.5	2	20	30984	FK-M5
M6	5	10	1200	0.04 ... 0.2	±0.5	2	23	2061	FK-M6
M8	7	13	2500	0.04 ... 0.2	±0.5	2	50	2062	FK-M8
M10	12	17	5000	0.05 ... 0.25	±0.7	2	210	2063	FK-M10
M10x1.25			5000	0.05 ... 0.25	±0.7	2	210	6140	FK-M10x1,25
M12	12	19	5000	0.05 ... 0.25	±0.7	2	210	2064	FK-M12
M12x1.25			5000	0.05 ... 0.25	±0.7	2	215	6141	FK-M12x1,25
M16	19	24	10000	0.05 ... 0.25	±1	2	670	2065	FK-M16
M16x1.5			10000	0.05 ... 0.25	±1	2	650	6142	FK-M16x1,5
M20x1.5	19	30	10000	0.05 ... 0.25	±1	2	720	6143	FK-M20x1,5
M27x2	24	41	30000	0.05 ... 0.25	±1	2	2100	10485	FK-M27x2
M36x2	32	55	40000	0.05 ... 0.25	±1	2	5800	10746	FK-M36x2

1) Corrosion resistance class CRC 2 to Festo standard FN 940070

Moderate corrosion stress. Indoor applications in which condensation may occur. External visible parts with primarily decorative requirements for the surface and which are in direct contact with the ambient atmosphere typical for industrial applications.

Self-aligning rod couplers CRFK, stainless steel

Technical data

Self-aligning rod coupler CRFK

Scope of delivery:

1 self-aligning rod coupler

Material:

Housing, nut, threaded pin:

High-alloy stainless steel

Cap: Elastomer

Free of copper and PTFE

RoHS-compliant

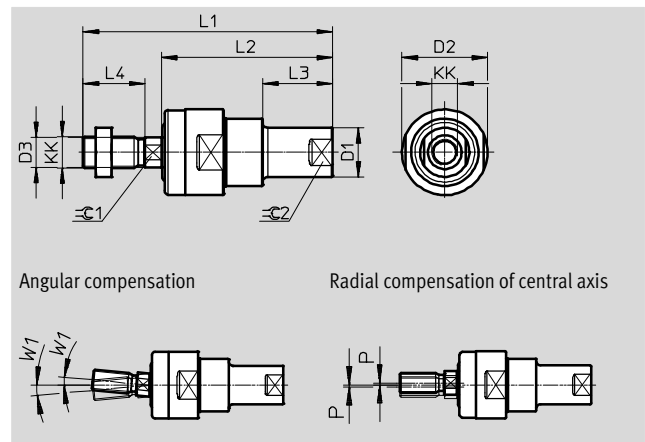

Dimensions and ordering data										
KK	D1 ∅	D2 ∅	D3 ∅	L1	L2	L3	L4	W1 [°]	≈C1	≈C2
M10x1.25	19	33	11.5	94	66	27	22	5	10	16
M12x1.25	19	33	11.5	96	66	27	24	5	10	16
M16x1.5	27	47	16	129	89	32	32	5	14	22
M20x1.5	35	57	21	165	114	40	40	5	18	30

KK	Tensile and compressive load max. [N]	Axial play [mm]	Radial deviation P [mm]	Ambient temperature [°C]
M10x1.25	2100	0.01 ... 0.03	±1	-20 ... +100
M12x1.25	2100	0.01 ... 0.03	±1	-20 ... +100
M16x1.5	5600	0.01 ... 0.03	±1	-20 ... +100
M20x1.5	13800	0.01 ... 0.03	±1	-20 ... +100

KK	CRC ¹⁾	Weight [g]	Part No.	Type
M10x1.25	4	230	2305778	CRFK-M10x1,25
M12x1.25	4	230	2305779	CRFK-M12x1,25
M16x1.5	4	670	2490673	CRFK-M16x1,5
M20x1.5	4	1280	2545677	CRFK-M20x1,5

1) Corrosion resistance class CRC 4 to Festo standard FN 940070
 Particularly high corrosion stress. Outdoor exposure under extreme corrosive conditions. Parts exposed to aggressive media, for instance in the chemical or food industries. These applications may need to be supported by special tests (→ also FN 940082) using appropriate media.

Coupling pieces KSG

Technical data



Coupling piece KSG

These coupling pieces connect the piston-rod thread of all types of cylinders to machine components which need to be driven. The pieces can compensate for radial alignment deviations of up to 1 mm.

Scope of delivery:

1 flange plate, 1 threaded coupling

Material:

Galvanised steel

Free of copper and PTFE

RoHS-compliant

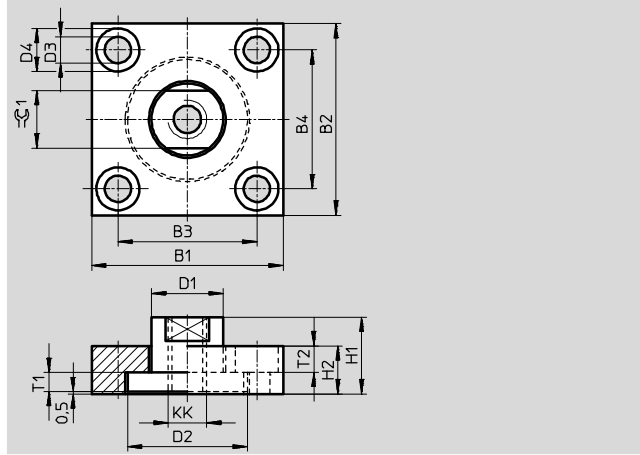

Dimensions and ordering data										
KK	B1	B2	B3	B4	B5 Max. radial backlash	D1 ∅ H11	D2 ∅ -0.2	D3 ∅ H13	D4 ∅ H13	H1
M10x1.25	60	37	36	23	1	20	32	6.6	11	24
M12x1.25	60	56	42	38		25	42	9	15	30
M16x1.5	80	80	58	58		30	52	11	18	32
M20x1.5	90	90	65	65		40	62	14	20	35
M27x2	90	90	65	65		40	62	14	20	35

KK	H2	T1 Min. axial backlash	T2	⌀C1	Max. tightening torque ¹⁾ [Nm]	CRC ²⁾	Weight [g]	Part No.	Type
M10x1.25	15	0.5	6.8	17	9.9	1	230	32963	KSG-M10x1,25
M12x1.25	20		9	19	24	1	450	32964	KSG-M12x1,25
M16x1.5	20		11	24	47	1	885	32965	KSG-M16x1,5
M20x1.5	20		13	36	82	1	1140	32966	KSG-M20x1,5
M27x2	20		13	36	82	1	1080	32967	KSG-M27x2

1) For mounting screws with standard threads and strength class 8.8

2) Corrosion resistance class CRC 1 to Festo standard FN 940070

Low corrosion stress. For dry indoor applications or transport and storage protection. Also applies to parts behind covers, in the non-visible interior area, and parts which are covered in the application (e.g. drive trunnions).

Coupling pieces KSZ

Technical data

Coupling piece KSZ

for non-rotating piston rods with male threads

These coupling pieces can be used to connect a cylinder with a non-rotating piston rod to another component with a defined orientation without rotating either the cylinder or other component.

Scope of delivery:

1 flange plate, 1 threaded coupling

Material:

Galvanised steel

Free of copper and PTFE

RoHS-compliant

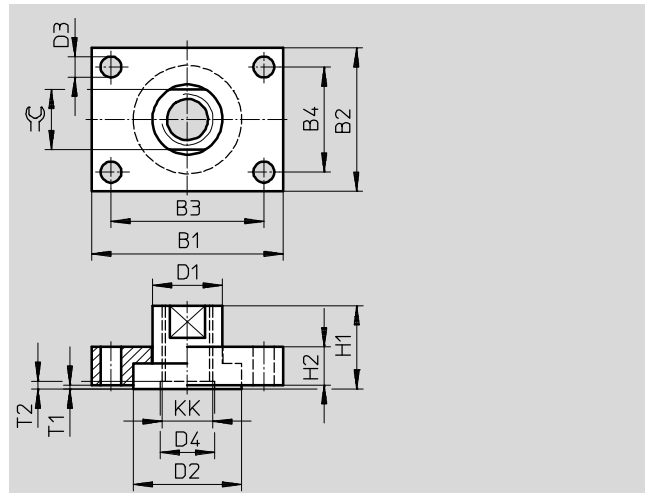

Dimensions and ordering data												
KK	B1	B2	B3	B4	D1	D2	D3	D4	H1	H2	T1	T2
					∅	∅	∅ H13	∅			min.	
M6	30	25	20	15	12-01	18	5.5	8	16	8	0.1	2
M8	35	30	25	20	14-01	20	5.5	-	22	8	0.1	-
M10x1.25	40	35	30	25	17-02	26	5.5	-	20	10	0.1	-
M12x1.25	50	40	40	30	17-02	26	5.5	-	22	12	0.1	-
M16x1.5	60	45	48	33	22-02	34	6.6	-	25	12	0.1	-
M20x1.5	72	50	57	35	30-02	44	9	-	32	15	0.1	-

KK	☉	Max. tightening torque ¹⁾	Max. tightening torque ²⁾	Max. tightening torque ³⁾	CRC ⁴⁾	Weight	Part No.	Type
		[Nm]	[Nm]	[Nm]		[g]		
M6	10	5.9	6.9	2.1	1	45	36123	KSZ-M6
M8	13	5.9	16	5	1	70	36124	KSZ-M8
M10x1.25	15	5.9	34	12	1	110	36125	KSZ-M10x1,25
M12x1.25	15	5.9	61	22	1	180	36126	KSZ-M12x1,25
M16x1.5	19	9.9	148	57	1	250	36127	KSZ-M16x1,5
M20x1.5	27	24	296	120	1	420	36128	KSZ-M20x1,5

1) For mounting screws with standard threads and strength class 8.8

2) For use with lock nut on piston rod

3) Torque which coupling can transmit with coefficient of friction μ 0,1 and 10x safety margin at max. permissible tightening torque

4) Corrosion resistance class CRC 1 to Festo standard FN 940070

Low corrosion stress. For dry indoor applications or transport and storage protection. Also applies to parts behind covers, in the non-visible interior area, and parts which are covered in the application (e.g. drive trunnions).

 Note: The torque on the coupling piece must not exceed the permissible torque on the cylinder. The mounting screws should be tightened evenly.

Hex nuts MSK

Technical data

Hex nut MSK

Material:
Galvanised steel

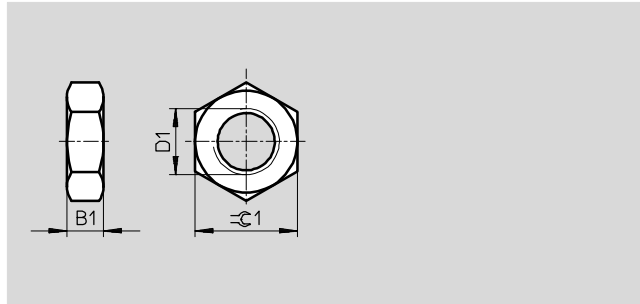
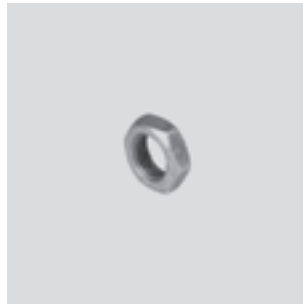

Dimensions and ordering data									
D1	B1	$\approx C1$	Conforms to ISO 8675	Based on ISO 8675	CRC ¹⁾	Weight [g]	Part No.	Type	PU ²⁾
M10x1.25	5	17	-	■	2	7	189005	MSK-M10x1,25	10
M12x1.25	6	19	-	■	2	9	189006	MSK-M12x1,25	
M16x1.5	8	24	■	-	2	18	189007	MSK-M16x1,5	

- 1) Corrosion resistance class CRC 2 to Festo standard FN 940070
Moderate corrosion stress. Indoor applications in which condensation may occur. External visible parts with primarily decorative requirements for the surface and which are in direct contact with the ambient atmosphere typical for industrial applications.
- 2) Packaging unit quantity

Adapter AD

Technical data

Adapter AD

Material:
Anodised aluminium

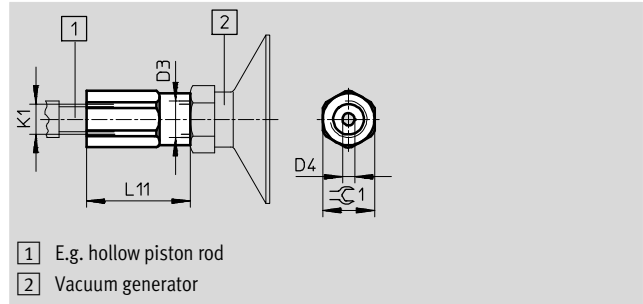

Dimensions and ordering data						
K1	D3	D4 Ø	L11	C1	Weight [g]	Part No. Type
M6	M5	2.3	27	10	6	157328 AD-M6-M5
M6	G1/8	2.3	27	13	9	157329 AD-M6-1/8
M6	G1/4	2.3	30	17	17	157330 AD-M6-1/4
M8	G1/8	3.2	29	13	8	157331 AD-M8-1/8
M8	G1/4	3.2	32	17	16	157332 AD-M8-1/4
M10x1.25	G1/8	4	31	13	10	157333 AD-M10x1,25-1/8
M10x1.25	G1/4	4	34	17	16	157334 AD-M10x1,25-1/4
M12x1.25	G1/4	6	34	17	28	160256 AD-M12x1,25-1/4
M12x1.25	G3/8	6	37	22	14	160257 AD-M12x1,25-3/8

Product Range and Company Overview

A Complete Suite and Company Overview

Our experienced engineers provide complete support at every stage of your development process, including: conceptualization, analysis, engineering, design, assembly, documentation, validation, and production.



Custom Automation Components
Complete custom engineered solutions



Custom Control Cabinets
Comprehensive engineering support and on-site services



Complete Systems
Shipment, stocking and storage services

The Broadest Range of Automation Components

With a comprehensive line of more than 30,000 automation components, Festo is capable of solving the most complex automation requirements.



Electromechanical
Electromechanical actuators, motors, controllers & drivers



Pneumatics
Pneumatic linear and rotary actuators, valves, and air supply



PLCs and I/O Devices
PLC's, operator interfaces, sensors and I/O devices

Supporting Advanced Automation... As No One Else Can!

Festo is a leading global manufacturer of pneumatic and electromechanical systems, components and controls for industrial automation, with more than 16,000 employees in 60 national headquarters serving more than 180 countries. For more than 80 years, Festo has continuously elevated the state of manufacturing with innovations and optimized motion control solutions that deliver higher performing, more profitable automated manufacturing and processing equipment. Our dedication to the advancement of automation extends beyond technology to the education and development of current and future automation and robotics designers with simulation tools, teaching programs, and on-site services.

Quality Assurance, ISO 9001 and ISO 14001 Certifications

Festo Corporation is committed to supply all Festo products and services that will meet or exceed our customers' requirements in product quality, delivery, customer service and satisfaction.

To meet this commitment, we strive to ensure a consistent, integrated, and systematic approach to management that will meet or exceed the requirements of the ISO 9001 standard for Quality Management and the ISO 14001 standard for Environmental Management.



© Copyright 2013, Festo Corporation. While every effort is made to ensure that all dimensions and specifications are correct, Festo cannot guarantee that publications are completely free of any error, in particular typing or printing errors. Accordingly, Festo cannot be held responsible for the same. For Liability and Warranty conditions, refer to our "Terms and Conditions of Sale", available from your local Festo office. All rights reserved. No part of this publication may be reproduced, distributed, or transmitted in any form or by any means, electronic, mechanical, photocopying or otherwise, without the prior written permission of Festo. All technical data subject to change according to technical update.



Printed on recycled paper at New Horizon Graphic, Inc., FSC certified as an environmental friendly printing plant.

Festo North America



**1 Festo Canada
Headquarters
Festo Inc.**
5300 Explorer Drive
Mississauga, ON
L4W 5G4

2 Montréal
5600, Trans-Canada
Pointe-Claire, QC
H9R 1B6

3 Québec City
2930, rue Watt#117
Québec, QC
G1X 4G3



**4 Festo United States
Headquarters
Festo Corporation**
395 Moreland Road
Hauppauge, NY
11788

5 Appleton
North 922 Tower View Drive, Suite N
Greenville, WI
54942

7 Detroit
1441 West Long Lake Road
Troy, MI
48098

6 Chicago
85 W Algonquin - Suite 340
Arlington Heights, IL
60005

8 Silicon Valley
4935 Southfront Road, Suite F
Livermore, CA
94550

Festo Regional Contact Center

Canadian Customers

Commercial Support:
Tel: 1 877 GO FESTO (1 877 463 3786)
Fax: 1 877 FX FESTO (1 877 393 3786)
Email: festo.canada@ca.festo.com

Technical Support:
Tel: 1 866 GO FESTO (1 866 463 3786)
Fax: 1 877 FX FESTO (1 877 393 3786)
Email: technical.support@ca.festo.com

USA Customers

Commercial Support:
Tel: 1 800 99 FESTO (1 800 993 3786)
Fax: 1 800 96 FESTO (1 800 963 3786)
Email: customer.service@us.festo.com

Technical Support:
Tel: 1 866 GO FESTO (1 866 463 3786)
Fax: 1 800 96 FESTO (1 800 963 3786)
Email: product.support@us.festo.com