

Push-in fittings NPQM



Push-in fittings NPQM

Features

FESTO

Application



Effortless selection of the right fitting. Quick Star offers a secure solution for every connection. The convenient push-in fitting system includes well over 1000 types of standard and function fittings.

Summary of tubing/fitting combinations			
Applications	Fitting	Tubing	Description
Standard	QS-B	PEN	Suitable for a wide range of tasks and attractively priced. Flexible thanks to highly resistant materials, easy to install thanks to optimised bending radii. High level of abrasion resistance in dynamic applications.
	QS	PUN	Maximum flexibility in standard applications thanks to an extremely wide range of options for combining the different types.
	QS	PAN	Meets all requirements, even for standard applications with increased pressure and temperature ranges.
High pressures	NPQM	PAN-MF	Meets DIN standard 73378: ideal for use in mobile pneumatics. Suitable for increased temperature ranges combined with high pressure ranges.
	NPQH	PAN-R	Powerful in pressure ranges up to 20 bar, for example in applications with the pressure booster DPA.
Resistant to chemicals, food safe and hydrolysis resistant	NPQP	PLN	Resistant to cleaning agents, FDA compliant and economical. Can be used instead of the combination with stainless steel fittings.
	NPKA	PUN-H	Hydrolysis resistant and suitable for water applications. Combination suitable for use in clean rooms, FDA compliant and corrosion resistant thanks to 100% polymer construction. Very easy to install thanks to the "one click principle".
	NPQH	PFAN	For high temperatures up to 150 °C. Suitable for use in the food industry, FDA compliant and resistant to cleaning agents.
	NPCK	PFAN	Easy to clean thanks to the union nut's edge-free design. Maximum resistance to corrosion (CRC 4) and FDA compliant. Suitable for a wide range of media.
	CRQS	PFAN	Maximum resistance to corrosion (CRC 4) and to aggressive acids and lyes.
Anti-static	NPQM	PUN-CM	Anti-static tubing plus solid metal fitting: maximum protection for electrical and electronic components.
Flame retardant	NPQM	PUN-V0	Very safe in areas where there is a risk of fire thanks to flame-retardant properties. The tubing has been tested to DIN 5510-2.
Resistant to welding spatter	NPQH	PUN-V0-C	Ideal for applications involving welding spatter. Reliable thanks to a tubing wall thickness of 2 mm for all diameters.
	QS-V0	PAN-V0	Safe even in the immediate vicinity of welding spatter thanks to the double-walled tubing with special fitting.

Push-in fittings NPQM

Features

Push-in fittings product range

QSM, Quick Star, Mini

Technical data → Internet: qsm



Miniature push-in fittings for maximum component density in confined spaces. For pneumatic applications with a temperature range up to 80 °C and a pressure range up to 14 bar. Tubing O.D.∅ of 2, 3, 4 and 6 mm with connecting threads M3, M5, M6, M7, R1/8 and G1/8.

QS, Quick Star, standard

Technical data → Internet: qs



Wide selection of push-in fittings for pneumatic applications with a temperature range up to 80 °C and a pressure range up to 14 bar. Tubing O.D.∅ of 4, 6, 8, 10, 12, 16 and 22 mm with connecting threads R1/8 ... R1/2 and G1/8 ... G1/2.

QSM-B, Quick Star, Mini

Technical data → Internet: qsm-b



Miniature push-in fittings for maximum component density in confined spaces. For core pneumatic applications with a temperature range up to 60 °C and a pressure range up to 10 bar. Tubing O.D.∅ of 3, 4 and 6 mm with connecting threads M3, M5, M7 and R1/8.

QS-B, Quick Star, standard

Technical data → Internet: qs-b



Push-in fittings for core pneumatic applications with a temperature range up to 60 °C and a pressure range up to 10 bar. Tubing O.D.∅ of 4, 6, 8, 10, 12 and 16 mm with connecting threads M5 and R1/8 ... R1/2.

CRQS, Quick Star, stainless steel

Technical data → Internet: crqs



Stainless steel push-in fitting. High corrosion resistance (CRC4) and chemical resistance with approval for use in the food and packaging industry. For pneumatic applications with a temperature range up to 120 °C and a pressure range up to 10 bar. Tubing O.D.∅ of 4, 6, 8, 10, 12 and 16 mm with connecting threads M5 and R1/8 ... R1/2.

QS-V0, Quick Star, flame-retardant

Technical data → Internet: qs-v0









Flame-retardant push-in fitting for use in all areas where there is a risk of fire, for example welding systems in the automotive industry and in the construction industry. For pneumatic applications with a temperature range up to 60 °C and a pressure range up to 10 bar. Tubing O.D.∅ of 4, 6, 8, 10 and 12 mm with connecting threads R1/8 ... R1/2 and G1/8 ... G1/2.

Push-in fittings NPQM

Features



Push-in fittings product range	
<p>NPQH</p> 	<p>Technical data → Internet: npqh</p> <p>All metal push-in fitting made of chemically nickel-plated brass. High corrosion resistance (CRC3) and chemical resistance with approval for use in the food and packaging industry. For pneumatic applications with a temperature range up to 150 °C and a pressure range up to 20 bar.</p> <p>Tubing O.D.∅ of 4, 6, 8, 10, 12 and 14 mm with connecting threads M5, M7 and G1/8 ... G1/2 .</p>
<p>NPQM</p> 	<p>Technical data → Internet: npqm</p> <p>Attractively priced metal push-in fitting for pneumatic applications with a temperature range up to 70 °C and a pressure range up to 16 bar.</p> <p>Tubing O.D.∅ of 3, 4, 6, 8, 10, 12 and 14 mm with connecting threads M5, M7 and G1/8 ... G1/2 .</p>
Functional push-in fittings product range	
<p>NPQP</p> 	<p>Technical data → Internet: npqp</p> <p>Polypropylene fitting for use in applications with extreme media influences. For pneumatic applications with a temperature range up to 60 °C and a pressure range up to 10 bar.</p> <p>Tubing O.D.∅ of 4, 6, 8, 10 and 12 mm with connecting threads R1/8 ... R1/2.</p>
<p>QSK, Quick Star, self-sealing push-in fitting</p> 	<p>Technical data → Internet: qsk</p> <p>Push-in fitting that blocks the air flow after the tubing is disconnected. For pneumatic applications with a temperature range up to 60 °C and a pressure range up to 14 bar.</p> <p>Tubing O.D.∅ of 4, 6, 8, 10 and 12 mm with connecting threads M5, R1/8 ... R1/2 and G1/8 ... G1/2.</p>
<p>QSR, Quick Star, rotary push-in fitting</p> 	<p>Technical data → Internet: qsr</p> <p>Push-in fitting with swivel connection, rotatable by 360°. The ball bearing enables rotating movements in the application up to max. 500 rpm. For pneumatic applications with a temperature range up to 60 °C and a pressure range up to 14 bar.</p> <p>Tubing O.D.∅ of 4, 6, 8, 10 and 12 mm with connecting threads M5, R1/8 ... R1/2 and G1/8 ... G1/2.</p>
Quick connectors product range	
<p>NPCK</p> 	<p>Technical data → Internet: npck</p> <p>Stainless steel fitting for use in areas subject to intensive cleaning. Highest level of corrosion resistance (CRC 4). For pneumatic applications with a temperature range up to 120 °C and a pressure range up to 12 bar.</p> <p>Tubing O.D.∅ of 4, 6, 8 and 10 mm with connecting thread M5 and G1/8 ... G3/8.</p>
Click fittings product range	
<p>NPKA</p> 	<p>Technical data → Internet: npka</p> <p>Plastic fitting for easy installation with one-hand operation. Hydrolysis resistant, FDA compliant and easy to clean. For pneumatic applications with a temperature range up to 60 °C and a pressure range up to 10 bar.</p> <p>Tubing O.D. 6 mm with connecting thread G1/8.</p>

Push-in fittings NPQM

Technical data

General technical data	
Size	Standard
Design	Push-pull principle
Type of seal on threaded plug	Sealing ring
Nominal tightening torque [Nm]	2 ±5% at male thread M5
	3 ±5% at male thread M7
	4 ±5% at male thread G1/8
	7 ±5% at male thread G1/4
	10 ±5% at male thread G3/8
	15 ±5% at male thread G1/2

Operating and environmental conditions	
Operating pressure complete [bar] temperature range	-0.95 ... +16
Operating medium	Compressed air in accordance with ISO 8573-1:2010 [7:-:-] Water as per manufacturer's declaration ¹⁾
Note on operating/pilot medium	Operation with lubricated medium possible
Ambient temperature [°C]	-20 ... +70
Corrosion resistance class CRC ²⁾	1
Food-industry approval	No

1) Additional information www.festo.com/sp → User documentation.

2) Corrosion resistance class CRC 1 to Festo standard FN 940070







Low corrosion stress. For dry indoor applications or transport and storage protection. Also applies to parts behind covers, in the non-visible interior area, and parts which are covered in the application (e.g. drive trunnions).

Materials	
Housing	Nickel-plated brass
Tubing seal	NBR
Note on materials	RoHS-compliant

Push-in fittings NPQM

Product range overview









Design	Version	Type	Connection D1					Connection D2		→ Page/ Internet
			M thread	R thread	G thread	Tubing O.D.	Push-in sleeve Ø	Tubing O.D.	Push-in sleeve Ø	
Inline	Push-in fitting – Male thread with internal/external hexagon									
		NPQM-D	–	–	G1/8 G1/4 G3/8 G1/2	–	–	4, 6, 8 6, 8, 10, 12 8, 10, 12, 14 10, 12, 14	–	9
	Push-in fitting – Female thread with external hexagon									
		NPQM-D	–	–	G1/8 G1/4	–	–	4, 6, 8 6, 8, 10	–	10
	Push-in fitting – Male thread with internal hexagon									
		NPQM-DK	M5 M7	–	–	–	–	4, 6 4, 6	–	10
	Push-in connector									
		NPQM-D	–	–	–	4 6 8 10 12 14	–	4 6 8 10 12 14	–	11
	Push-in connector with push-in sleeve									
		NPQM-D	–	–	–	4 6 8 10 12	–	–	6, 8 4, 8, 10, 12, 14 6, 10, 12, 14 12, 14 14	11
	Push-in sleeve									
		NPQM-D	–	–	–	–	4 6 8 10 12 14	–	4 6 8 10 12 14	12
Push-in bulkhead connector										
	NPQM-H	–	–	–	4 6 8 10 12	–	–	–	12	

Push-in fittings NPQM

Product range overview





FESTO

Design	Version	Type	Connection D1					Connection D2		→ Page/ Internet	
			M thread	R thread	G thread	Tubing O.D.	Push-in sleeve Ø	Tubing O.D.	Push-in sleeve Ø		
L-shape	Push-in L-fitting – Male thread with external hexagon										
		NPQM-L	M5	-	-	-	-	-	4, 6	-	13
			-		G ¹ / ₈				4, 6, 8		
					G ¹ / ₄				6, 8, 10, 12		
					G ³ / ₈				8, 10, 12, 14		
					G ¹ / ₂				10, 12, 14		
	Push-in L-fitting – Male thread with internal hexagon										
		NPQM-LK	M5	-	-	-	-	-	3, 4	-	14
			-		G ¹ / ₈				4, 6, 8		
					G ¹ / ₄				6, 8, 10		
					G ³ / ₈				10		
	Push-in L-fitting – Male thread with external hexagon										
		NPQM-LH	M5	-	-	-	-	-	4, 6	-	15
			-		G ¹ / ₈				4, 6, 8		
					G ¹ / ₄				6, 8		
					G ³ / ₈				8, 10, 12		
	Two-way multiple distributor – Male thread with internal hexagon										
		NPQM-LFK	-	-	G ¹ / ₈	-	-	-	4, 6, 8	-	16
	G ¹ / ₄				6, 8						
Push-in L-connector											
	NPQM-L	-	-	-	4	-	-	4	-	17	
					6			6			
					8			8			
					10			10			
					12			12			
					14			14			
Push-in L-connector with push-in sleeve											
	NPQM-L	-	-	-	4	-	-	4	-	17	
					6			6			
					8			8			
					10			10			

Push-in fittings NPQM

Product range overview



Design	Version	Type	Connection D1					Connection D2		→ Page/ Internet
			M thread	R thread	G thread	Tubing O.D.	Push-in sleeve Ø	Tubing O.D.	Push-in sleeve Ø	
T-shape	Push-in T-fitting – Male thread with external hexagon									
		NPQM-T	-	-	G 1/8	-	-	4, 6, 8	-	18
					G 1/4			6, 8, 10		
					G 3/8			8, 10, 12		
					G 1/2			12		
	Push-in T-connector									
		NPQM-T	-	-	-	-	-	4	-	19
								6		
								8		
								10		
12										
14	14									
Push-in T-connector with push-in sleeve										
	NPQM-T	-	-	-	-	-	4	-	19	
							6			
							8			
							10			10
Y-shape	Push-in Y-connector									
		NPQM-Y	-	-	-	-	-	4	-	20
								6		
								8		
								10		
								12		
		NPQM-Y reducing	-	-	-	-	-	6	-	20
								8		
10								8		

Push-in fittings NPQM

Technical data

Push-in fitting NPQM-D

Male thread with internal/external hexagon

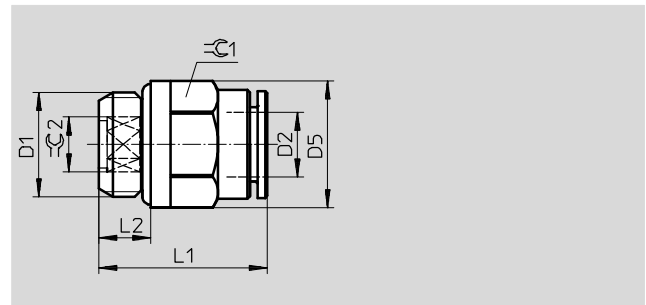

Dimensions and ordering data											
Connection	Nominal size [mm]	Tubing O.D.	D5 \varnothing	L1	L2	$\approx C1$	$\approx C2$	Weight/ piece [g]	Part No.	Type	PU ¹⁾
D1	[mm]	D2									
G thread with sealing ring											
G ¹ / ₈	3.0	4	13.0	16.5	5.0	9	3	6.1	558661	NPQM-D-G18-Q4-P10	10
	4.0	6	13.5	19.5	5.0	12	4	9.0	558662	NPQM-D-G18-Q6-P10	10
	6.0	8	13.0	23.5	5.0	13	6	11.4	558663	NPQM-D-G18-Q8-P10	10
G ¹ / ₄	4.0	6	16.0	19.5	6.5	12	4	12.7	558664	NPQM-D-G14-Q6-P10	10
	6.0	8	16.0	21.5	6.5	14	6	13.6	558665	NPQM-D-G14-Q8-P10	10
	8.0	10	16.0	27.5	6.5	15	8	17.4	558666	NPQM-D-G14-Q10-P10	10
	8.0	12	16.0	28.5	6.5	19	8	26.2	558667	NPQM-D-G14-Q12-P10	10
G ³ / ₈	6.0	8	20.0	21.0	7.0	14	6	20.1	558668	NPQM-D-G38-Q8-P10	10
	8.0	10	20.0	25.0	7.0	16	8	22.6	558669	NPQM-D-G38-Q10-P10	10
	10.0	12	20.0	28.5	7.0	19	10	28.9	558670	NPQM-D-G38-Q12-P10	10
	10.0	14	20.0	32.0	7.0	22	10	37.5	570450	NPQM-D-G38-Q14-P10	1
G ¹ / ₂	8.0	10	25.0	25.5	8.5	16	8	34.5	558671	NPQM-D-G12-Q10-P10	10
	10.0	12	25.0	26.5	8.5	19	10	36.1	558672	NPQM-D-G12-Q12-P10	10
	12.0	14	25.0	32.0	8.5	22	12	42.4	570451	NPQM-D-G12-Q14-P10	1

1) Packaging unit

Push-in fittings NPQM

Technical data



Push-in fitting NPQM-D

Female thread with external hexagon

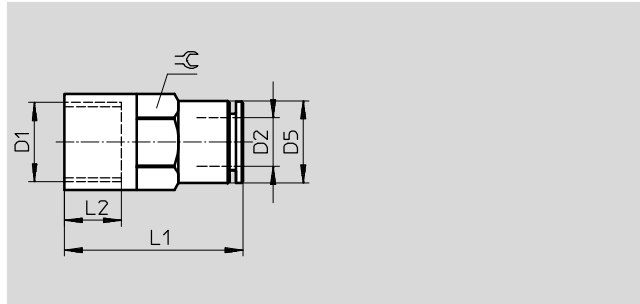

Dimensions and ordering data										
Connection	Nominal size [mm]	Tubing O.D. D2	D5 Ø	L1	L2	≈	Weight/ piece [g]	Part No.	Type	PU ¹⁾
G thread										
G ¹ / ₈	3.0	4	9.0	23.5	7.5	9	10.0	558674	NPQM-D-G18F-Q4-P10	10
	5.0	6	12.0	26.0	7.5	12	15.1	558675	NPQM-D-G18F-Q6-P10	10
	7.0	8	14.0	26.0	7.5	14	17.5	558676	NPQM-D-G18F-Q8-P10	10
G ¹ / ₄	5.0	6	12.0	30.0	11.0	12	18.5	558678	NPQM-D-G14F-Q6-P10	10
	7.0	8	14.0	30.0	11.0	14	20.2	558679	NPQM-D-G14F-Q8-P10	10
	9.0	10	16.0	32.0	11.0	16	24.4	558680	NPQM-D-G14F-Q10-P10	10

1) Packaging unit

Push-in fitting NPQM-DK

Male thread with internal hexagon

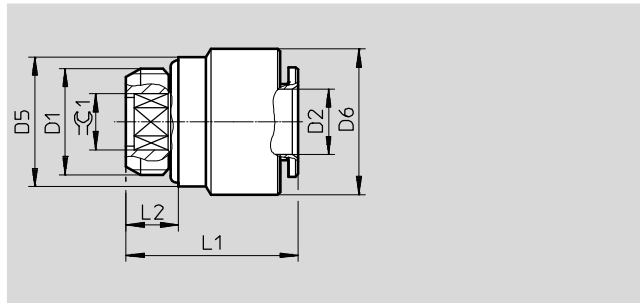

Dimensions and ordering data											
Connection	Nominal size [mm]	Tubing O.D. D2	D5 Ø	D6 Ø	L1	L2	≈	Weight/ piece [g]	Part No.	Type	PU ¹⁾
Metric thread with sealing ring											
M5	2.5	4	8.0	9.0	19.0	4.0	2.5	4.6	558657	NPQM-DK-M5-Q4-P10	10
	2.5	6	8.0	12.0	22.0	4.0	2.5	8.6	558658	NPQM-DK-M5-Q6-P10	10
M7	3.0	4	9.0	9.0	20.0	5.0	3.0	-	558659	NPQM-DK-M7-Q4-P10	10
	3.0	6	9.0	12.0	23.0	5.0	3.0	-	558660	NPQM-DK-M7-Q6-P10	10

1) Packaging unit

Push-in fittings NPQM

Technical data

FESTO

Push-in connector NPQM-D

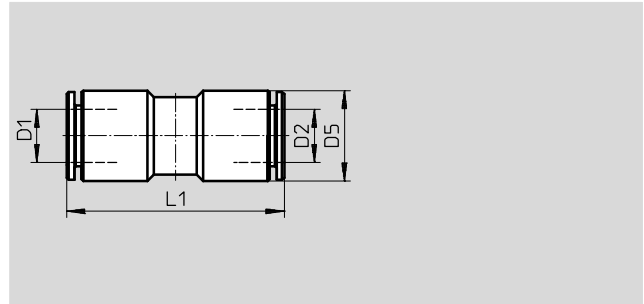

Dimensions and ordering data								
Tubing O.D.	Nominal size	Tubing O.D.	D5	L1	Weight/ piece	Part No.	Type	PU ¹⁾
D1	[mm]	D2	∅		[g]			
4	3.0	4	9.0	28.0	6.8	558760	NPQM-D-Q4-E-P10	10
6	5.0	6	12.0	33.5	15.0	558761	NPQM-D-Q6-E-P10	10
8	7.0	8	14.0	34.0	18.0	558762	NPQM-D-Q8-E-P10	10
10	9.0	10	16.0	38.5	22.5	558763	NPQM-D-Q10-E-P10	10
12	11.0	12	19.0	41.0	36.6	558764	NPQM-D-Q12-E-P10	10
14	13.0	14	22.0	47.0	47.4	570452	NPQM-D-Q14-E-P10	1

1) Packaging unit

Push-in connector NPQM-D with push-in sleeve

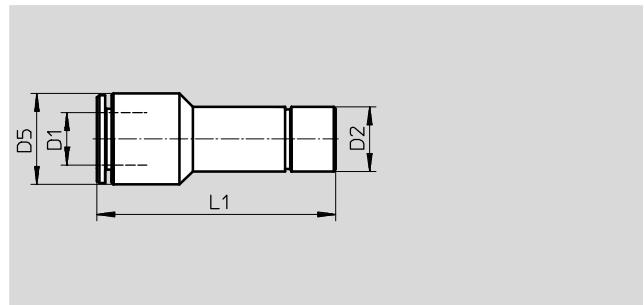

Dimensions and ordering data								
Tubing O.D.	Nominal size	Push-in sleeve ∅	D5	L1	Weight/ piece	Part No.	Type	PU ¹⁾
D1	[mm]	D2	∅		[g]			
4	3.0	6	9.0	33.5	7.0	558765	NPQM-D-Q4-S6-P10	10
	3.5	8	9.0	33.5	10.0	558766	NPQM-D-Q4-S8-P10	10
6	2.5	4	12.0	35.5	10.0	558767	NPQM-D-Q6-S4-P10	10
	5.0	8	12.0	35.0	11.5	558768	NPQM-D-Q6-S8-P10	10
	5.5	10	12.0	36.5	15.5	558769	NPQM-D-Q6-S10-P10	10
	5.5	12	12.0	35.5	22.2	558770	NPQM-D-Q6-S12-P10	10
	5.0	14	14.0	37.5	25.0	570457	NPQM-D-Q6-S14-P10	1
8	4.0	6	14.0	39.5	13.5	558771	NPQM-D-Q8-S6-P10	10
	7.0	10	14.0	37.0	15.0	558772	NPQM-D-Q8-S10-P10	10
	7.0	12	14.0	39.0	23.0	558773	NPQM-D-Q8-S12-P10	10
	7.0	14	14.0	38.5	31.5	570458	NPQM-D-Q8-S14-P10	1
10	9.0	12	16.0	42.0	20.0	558774	NPQM-D-Q10-S12-P10	10
	9.0	14	16.0	42.0	29.5	570456	NPQM-D-Q10-S14-P10	1
12	11.0	14	19.0	43.0	24.0	570459	NPQM-D-Q12-S14-P10	1

1) Packaging unit

Push-in fittings NPQM

Technical data



Push-in sleeve NPQM-D

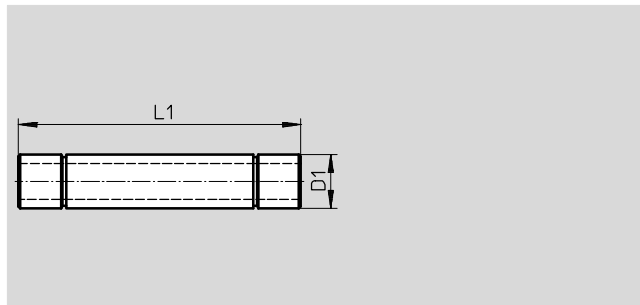

Dimensions and ordering data						
Push-in sleeve Ø D1	Nominal size [mm]	L1	Weight/ piece [g]	Part No.	Type	PU ¹⁾
4	2.0	35.0	2.8	558811	NPQM-D-S4-E-P10	10
6	4.0	40.0	5.5	558812	NPQM-D-S6-E-P10	10
8	6.0	42.0	7.5	558813	NPQM-D-S8-E-P10	10
10	8.0	50.0	11.0	558814	NPQM-D-S10-E-P10	10
12	10.0	53.0	14.0	558815	NPQM-D-S12-E-P10	10
14	12.0	54.0	18.5	570455	NPQM-D-S14-E-P10	1

1) Packaging unit

Push-in bulkhead connector NPQM-H

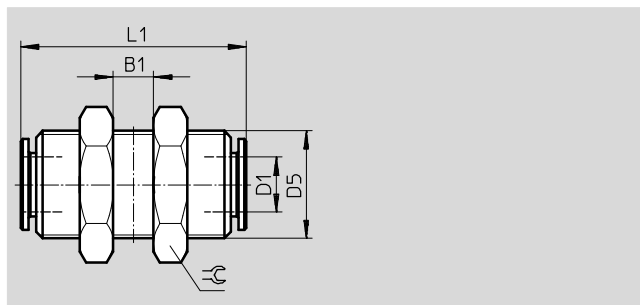

Dimensions and ordering data									
Tubing O.D. D1	Nominal size [mm]	D5	B1	L1	⌀	Weight/ piece [g]	Part No.	Type	PU ¹⁾
4	3.0	M12x1	11.0	28.0	16	23.5	558806	NPQM-H-Q4-E-P10	10
6	5.0	M14x1	16.0	34.0	18	33.0	558807	NPQM-H-Q6-E-P10	10
8	7.0	M16x1	17.0	34.0	20	39.5	558808	NPQM-H-Q8-E-P10	10
10	9.0	M18x1	19.0	39.0	22	51.5	558809	NPQM-H-Q10-E-P10	10
12	11.0	M20x1	20.0	41.0	24	60.0	558810	NPQM-H-Q12-E-P10	10

1) Packaging unit

Push-in fittings NPQM

Technical data



Push-in L-fitting NPQM-L
Male thread with external hexagon

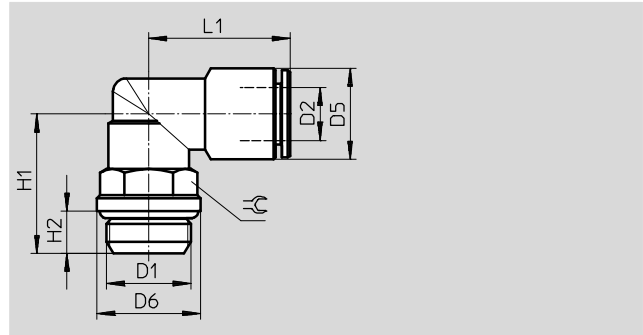

Dimensions and ordering data												
Connection	Nominal size [mm]	Tubing O.D. D2	D5 Ø	D6 Ø	H1	H2	L1	≅	Weight/ piece [g]	Part No.	Type	PU ¹⁾
Metric thread with sealing ring												
M5	3.0	4	9.0	8.0	14.0	4.0	17.5	9	8.8	558704	NPQM-L-M5-Q4-P10	10
	3.5	6	12.0	8.0	14.0	4.0	20.5	9	11.9	558705	NPQM-L-M5-Q6-P10	10
G thread with sealing ring												
G ¹ / ₈	3.0	4	9.0	13.0	18.0	5.0	19.5	13	15.7	558708	NPQM-L-G18-Q4-P10	10
	5.0	6	12.0	13.0	18.0	5.0	22.0	13	18.5	558709	NPQM-L-G18-Q6-P10	10
	5.5	8	14.0	13.0	18.0	5.0	22.5	13	22.0	558710	NPQM-L-G18-Q8-P10	10
G ¹ / ₄	5.0	6	12.0	16.0	21.5	6.5	22.0	13	21.8	558711	NPQM-L-G14-Q6-P10	10
	5.5	8	14.0	16.0	21.5	6.5	22.5	13	25.3	558712	NPQM-L-G14-Q8-P10	10
	8.5	10	16.0	16.0	22.0	6.5	26.0	16	34.0	558713	NPQM-L-G14-Q10-P10	10
	11.0	12	19.0	16.0	25.5	6.5	28.5	20	58.5	558714	NPQM-L-G14-Q12-P10	10
G ³ / ₈	6.0	8	14.0	20.0	25.5	7.0	23.0	16	37.7	558715	NPQM-L-G38-Q8-P10	10
	8.5	10	16.0	20.0	25.5	7.0	26.0	16	39.2	558716	NPQM-L-G38-Q10-P10	10
	11.0	12	19.0	20.0	26.0	7.0	28.5	20	56.1	558717	NPQM-L-G38-Q12-P10	10
	12.0	14	22.0	20.0	26.0	7.0	31.0	20	61.6	570460	NPQM-L-G38-Q14-P10	1
G ¹ / ₂	8.5	10	16.0	25.0	27.5	8.5	26.0	16	43.2	558718	NPQM-L-G12-Q10-P10	10
	11.0	12	19.0	25.0	30.5	8.5	28.5	20	65.1	558719	NPQM-L-G12-Q12-P10	10
	12.0	14	22.0	25.0	30.5	8.5	31.0	20	69.9	570461	NPQM-L-G12-Q14-P10	1

1) Packaging unit

Push-in fittings NPQM

Technical data



Push-in L-fitting NPQM-LK

Male thread with internal hexagon

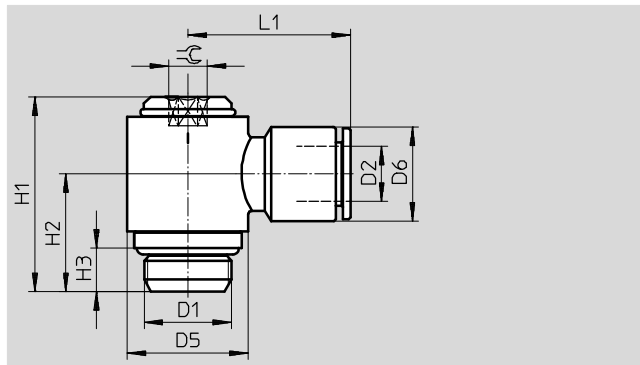

Dimensions and ordering data													
Connection	Nominal size [mm]	Tubing O.D. D2	D5 Ø	D6 Ø	H1	H2	H3	L1	⊕	Weight/ piece [g]	Part No.	Type	PU ¹⁾
Metric thread with sealing ring													
M5	2.0	3	10.0	7.0	19.0	11.0	4.0	15.0	3	8.1	558816	NPQM-LK-M5-Q3-P10	10
	2.0	4	10.0	9.0	19.0	11.0	4.0	18.5	3	10.1	558817	NPQM-LK-M5-Q4-P10	10
G thread with sealing ring													
G ¹ / ₈	4.0	4	14.0	9.0	25.5	15.0	5.0	20.5	4	22.2	558818	NPQM-LK-G18-Q4-P10	10
	4.0	6	14.0	12.0	25.5	15.0	5.0	22.5	4	24.4	558819	NPQM-LK-G18-Q6-P10	10
	4.0	8	14.0	14.0	25.5	15.0	5.0	23.5	4	25.7	558820	NPQM-LK-G18-Q8-P10	10
G ¹ / ₄	5.5	6	18.0	12.0	29.0	17.5	6.5	24.0	5	39.3	558821	NPQM-LK-G14-Q6-P10	10
	5.5	8	18.0	14.0	29.0	17.5	6.5	24.5	5	39.1	558822	NPQM-LK-G14-Q8-P10	10
	5.5	10	18.0	16.0	29.0	17.5	6.5	27.0	5	43.6	558823	NPQM-LK-G14-Q10-P10	10
G ³ / ₈	7.0	10	22.0	16.0	32.5	19.5	7.0	29.0	6	62.2	558825	NPQM-LK-G38-Q10-P10	10

1) Packaging unit

Push-in fittings NPQM

Technical data



Push-in L-fitting NPQM-LH
Male thread with external hexagon

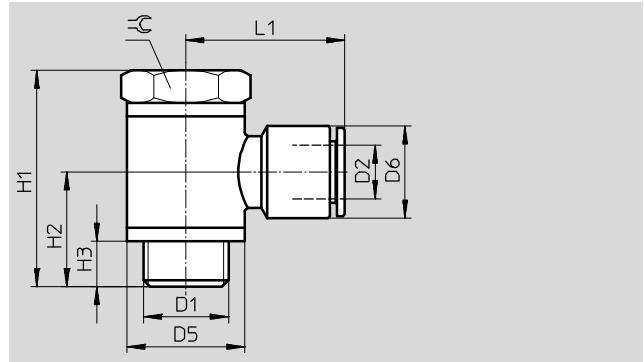

Dimensions and ordering data													
Connection	Nominal size [mm]	Tubing O.D. D2	D5 Ø	D6 Ø	H1	H2	H3	L1	⌀	Weight/ piece [g]	Part No.	Type	PU ¹⁾
Metric thread with sealing ring													
M5	3.0	4	10.0	9.0	18.5	10.0	4.0	18.5	8	-	558827	NPQM-LH-M5-Q4-P10	10
	3.5	6	10.0	12.0	18.5	10.0	4.0	21.5	8	-	558828	NPQM-LH-M5-Q6-P10	10
G thread with sealing ring													
G ¹ / ₈	3.0	4	14.0	9.0	27.0	14.0	5.0	20.5	14	-	558829	NPQM-LH-G18-Q4-P10	10
	5.0	6	14.0	12.0	27.0	14.0	5.0	22.5	14	-	558830	NPQM-LH-G18-Q6-P10	10
	6.5	8	14.0	14.0	27.0	14.0	5.0	23.5	14	-	558831	NPQM-LH-G18-Q8-P10	10
G ¹ / ₄	5.0	6	18.0	12.0	31.5	16.5	6.5	24.0	17	-	558832	NPQM-LH-G14-Q6-P10	10
	6.5	8	18.0	14.0	31.5	16.5	6.5	24.5	17	-	558833	NPQM-LH-G14-Q8-P10	10
G ³ / ₈	7.0	8	22.0	14.0	36.0	18.5	7.0	26.5	20	-	558834	NPQM-LH-G38-Q8-P10	10
	8.5	10	22.0	16.0	36.0	18.5	7.0	29.0	20	-	558835	NPQM-LH-G38-Q10-P10	10
	10.5	12	22.0	19.0	36.0	18.5	7.0	29.5	20	-	558836	NPQM-LH-G38-Q12-P10	10

1) Packaging unit

Push-in fittings NPQM

Technical data



Multiple distributor NPQM-LFK
Male thread with internal hexagon

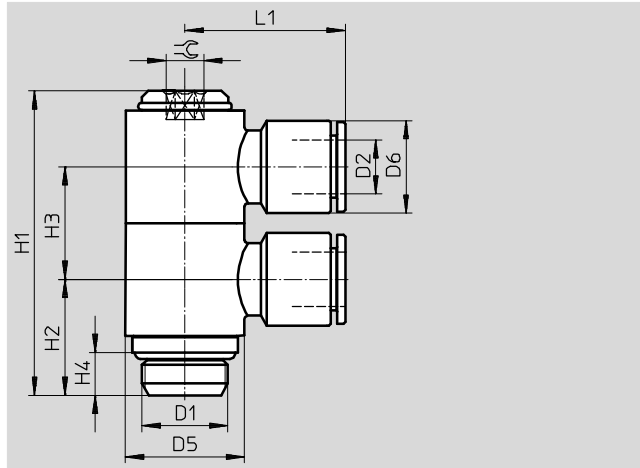

Dimensions and ordering data														
Connection	Nominal size	Tubing O.D.	D5	D6	H1	H2	H3	H4	L1	⊖	Weight/ piece	Part No.	Type	PU ¹⁾
D1	[mm]	D2	∅	∅							[g]			
G ¹ / ₈	4.0	4	14.0	9.0	40.5	15.0	15.0	5.0	20.5	4	40.0	558837	NPQM-LFK-G18-Q4-P10	10
	4.0	6	14.0	12.0	40.5	15.0	15.0	5.0	22.5	4	46.0	558838	NPQM-LFK-G18-Q6-P10	10
	4.0	8	14.0	14.0	40.5	15.0	15.0	5.0	23.5	4	50.0	558839	NPQM-LFK-G18-Q8-P10	10
G ¹ / ₄	5.5	6	18.0	12.0	46.0	17.5	17.0	6.5	24.0	5	69.5	558840	NPQM-LFK-G14-Q6-P10	10
	5.5	8	18.0	14.0	46.0	17.5	17.0	6.5	24.5	5	69.5	558841	NPQM-LFK-G14-Q8-P10	10

1) Packaging unit

Push-in fittings NPQM

Technical data

Push-in L-connector NPQM-L

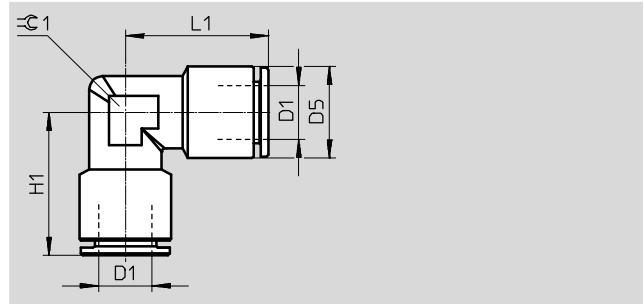

Dimensions and ordering data									
Tubing O.D.	Nominal size	D5	H1	L1	⌀ C1	Weight/ piece	Part No.	Type	PU ¹⁾
D1	[mm]	∅				[g]			
4	3.0	9.0	17.5	17.5	8	9.0	558776	NPQM-L-Q4-E-P10	10
6	5.0	12.0	20.5	20.5	10	16.5	558777	NPQM-L-Q6-E-P10	10
8	7.0	14.0	22.5	22.5	12	22.0	558778	NPQM-L-Q8-E-P10	10
10	9.0	16.0	25.0	25.0	14	29.5	558779	NPQM-L-Q10-E-P10	10
12	11.0	19.0	26.5	26.5	18	48.5	558780	NPQM-L-Q12-E-P10	10
14	12.0	22.0	31.5	31.5	18	58.0	570453	NPQM-L-Q14-E-P10	1

1) Packaging unit

Push-in L-connector NPQM-L with push-in sleeve

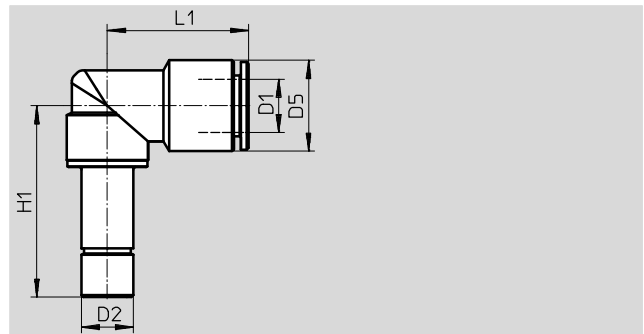

Dimensions and ordering data									
Tubing O.D.	Nominal size	Push-in sleeve ∅	D5	H1	L1	Weight/ piece	Part No.	Type	PU ¹⁾
D1	[mm]	D2	∅			[g]			
4	3.0	4	9.0	25.5	19.5	14.0	558781	NPQM-L-Q4-S4-P10	10
6	5.0	6	12.0	29.5	22.0	17.0	558782	NPQM-L-Q6-S6-P10	10
8	5.5	8	14.0	29.5	22.5	20.5	558783	NPQM-L-Q8-S8-P10	10
10	8.5	10	16.0	33.5	26.0	30.0	558784	NPQM-L-Q10-S10-P10	10

1) Packaging unit

Push-in fittings NPQM

Technical data



Push-in T-fitting NPQM-T

Male thread with external hexagon

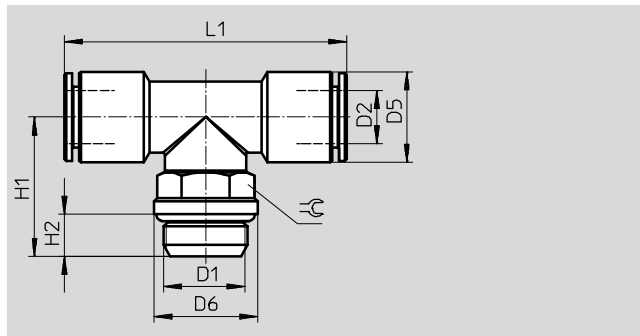

Dimensions and ordering data												
Connection	Nominal size [mm]	Tubing O.D. D2	D5 Ø	D6 Ø	H1	H2	L1	≈C	Weight/ piece [g]	Part No.	Type	PU ¹⁾
G thread with sealing ring												
G ¹ / ₈	3.0	4	9.0	13.0	18.0	5.0	39.0	13	20.2	558736	NPQM-T-G18-Q4-P10	10
	5.0	6	12.0	13.0	18.0	5.0	44.0	13	25.2	558737	NPQM-T-G18-Q6-P10	10
	5.5	8	14.0	13.0	18.0	5.0	45.0	13	30.7	558738	NPQM-T-G18-Q8-P10	10
G ¹ / ₄	5.0	6	12.0	16.0	21.5	6.5	44.0	13	29.1	558739	NPQM-T-G14-Q6-P10	10
	5.5	8	14.0	16.0	21.5	6.5	45.0	13	33.6	558740	NPQM-T-G14-Q8-P10	10
	8.5	10	16.0	16.0	22.0	6.5	52.0	16	44.4	558741	NPQM-T-G14-Q10-P10	10
G ³ / ₈	6.0	8	14.0	20.0	25.5	7.0	46.0	16	46.4	558743	NPQM-T-G38-Q8-P10	10
	8.5	10	16.0	20.0	25.5	7.0	52.0	16	49.7	558744	NPQM-T-G38-Q10-P10	10
	11.0	12	19.0	20.0	26.0	7.0	57.0	20	75.3	558745	NPQM-T-G38-Q12-P10	10
G ¹ / ₂	11.0	12	19.0	25.0	30.5	8.5	57.0	20	82.0	558747	NPQM-T-G12-Q12-P10	10

1) Packaging unit

Push-in fittings NPQM

Technical data

Push-in T-connector NPQM-T

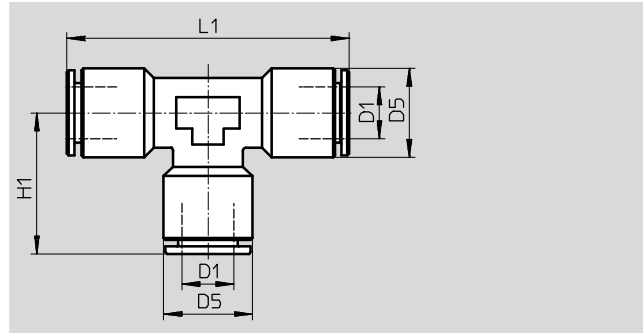

Dimensions and ordering data								
Tubing O.D. D1	Nominal size [mm]	D5 Ø	H1	L1	Weight/ piece [g]	Part No.	Type	PU ¹⁾
4	3.0	9.0	17.5	35.0	12.5	558786	NPQM-T-Q4-E-P10	10
6	5.0	12.0	20.0	40.0	22.5	558787	NPQM-T-Q6-E-P10	10
8	7.0	14.0	21.0	42.0	28.4	558788	NPQM-T-Q8-E-P10	10
10	9.0	16.0	24.5	49.0	39.2	558789	NPQM-T-Q10-E-P10	10
12	11.0	19.0	26.0	52.0	61.3	558790	NPQM-T-Q12-E-P10	10
14	12.0	22.0	30.5	61.0	77.1	570454	NPQM-T-Q14-E-P10	1

1) Packaging unit

Push-in T-connector NPQM-T with push-in sleeve

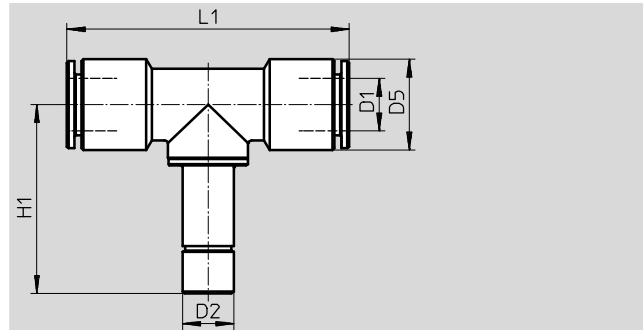

Dimensions and ordering data									
Tubing O.D. D1	Nominal size [mm]	Push-in sleeve Ø D2	D5 Ø	H1	L1	Weight/ piece [g]	Part No.	Type	PU ¹⁾
4	3.0	4	9.0	25.5	39.0	18.5	558791	NPQM-T-Q4-S4-P10	10
6	5.0	6	12.0	29.5	44.0	24.5	558792	NPQM-T-Q6-S6-P10	10
8	5.5	8	14.0	29.5	45.0	29.0	558793	NPQM-T-Q8-S8-P10	10
10	8.5	10	16.0	33.5	52.0	41.0	558794	NPQM-T-Q10-S10-P10	10

1) Packaging unit

Push-in fittings NPQM

Technical data



Push-in Y-connector NPQM-Y

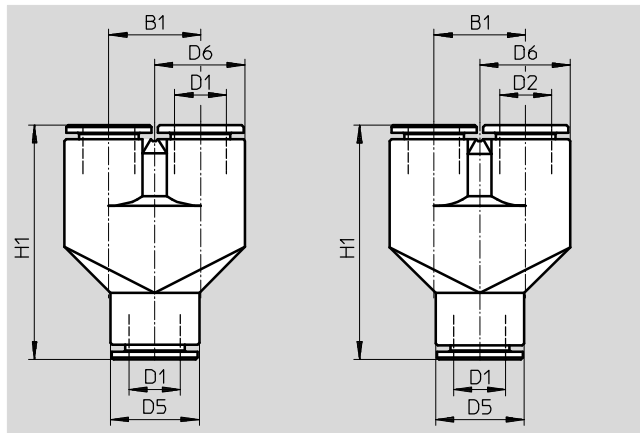

Dimensions and ordering data										
Tubing O.D. D1	Nominal size [mm]	Tubing O.D. D2	D5 Ø	D6 Ø	B1	H1	Weight/ piece [g]	Part No.	Type	PU ¹⁾
4	3.5	-	9.0	9.25	9.5	29.5	13.5	558798	NPQM-Y-Q4-E-P10	10
6	5.5	-	12.0	12.25	12.5	36.0	32.0	558799	NPQM-Y-Q6-E-P10	10
8	7.5	-	14.0	14.25	14.5	37.5	42.5	558800	NPQM-Y-Q8-E-P10	10
10	9.5	-	16.0	16.25	16.5	44.5	-	558801	NPQM-Y-Q10-E-P10	10
12	11.5	-	19.0	19.25	19.5	49.0	-	558802	NPQM-Y-Q12-E-P10	10
Reducing										
6	3.5	4	12.0	12.25	12.5	36.0	-	558803	NPQM-Y-Q6-Q4-P10	10
8	5.5	6	14.0	14.25	14.5	38.5	-	558804	NPQM-Y-Q8-Q6-P10	10
10	7.5	8	16.0	16.25	16.5	44.0	-	558805	NPQM-Y-Q10-Q8-P10	10

1) Packaging unit

Product Range and Company Overview

A Complete Suite and Company Overview

Our experienced engineers provide complete support at every stage of your development process, including: conceptualization, analysis, engineering, design, assembly, documentation, validation, and production.



Custom Automation Components
Complete custom engineered solutions



Custom Control Cabinets
Comprehensive engineering support and on-site services



Complete Systems
Shipment, stocking and storage services

The Broadest Range of Automation Components

With a comprehensive line of more than 30,000 automation components, Festo is capable of solving the most complex automation requirements.



Electromechanical
Electromechanical actuators, motors, controllers & drivers



Pneumatics
Pneumatic linear and rotary actuators, valves, and air supply



PLCs and I/O Devices
PLC's, operator interfaces, sensors and I/O devices

Supporting Advanced Automation... As No One Else Can!

Festo is a leading global manufacturer of pneumatic and electromechanical systems, components and controls for industrial automation, with more than 16,000 employees in 60 national headquarters serving more than 180 countries. For more than 80 years, Festo has continuously elevated the state of manufacturing with innovations and optimized motion control solutions that deliver higher performing, more profitable automated manufacturing and processing equipment. Our dedication to the advancement of automation extends beyond technology to the education and development of current and future automation and robotics designers with simulation tools, teaching programs, and on-site services.

Quality Assurance, ISO 9001 and ISO 14001 Certifications

Festo Corporation is committed to supply all Festo products and services that will meet or exceed our customers' requirements in product quality, delivery, customer service and satisfaction.

To meet this commitment, we strive to ensure a consistent, integrated, and systematic approach to management that will meet or exceed the requirements of the ISO 9001 standard for Quality Management and the ISO 14001 standard for Environmental Management.



© Copyright 2013, Festo Corporation. While every effort is made to ensure that all dimensions and specifications are correct, Festo cannot guarantee that publications are completely free of any error, in particular typing or printing errors. Accordingly, Festo cannot be held responsible for the same. For Liability and Warranty conditions, refer to our "Terms and Conditions of Sale", available from your local Festo office. All rights reserved. No part of this publication may be reproduced, distributed, or transmitted in any form or by any means, electronic, mechanical, photocopying or otherwise, without the prior written permission of Festo. All technical data subject to change according to technical update.



Printed on recycled paper at New Horizon Graphic, Inc., FSC certified as an environmental friendly printing plant.

Festo North America

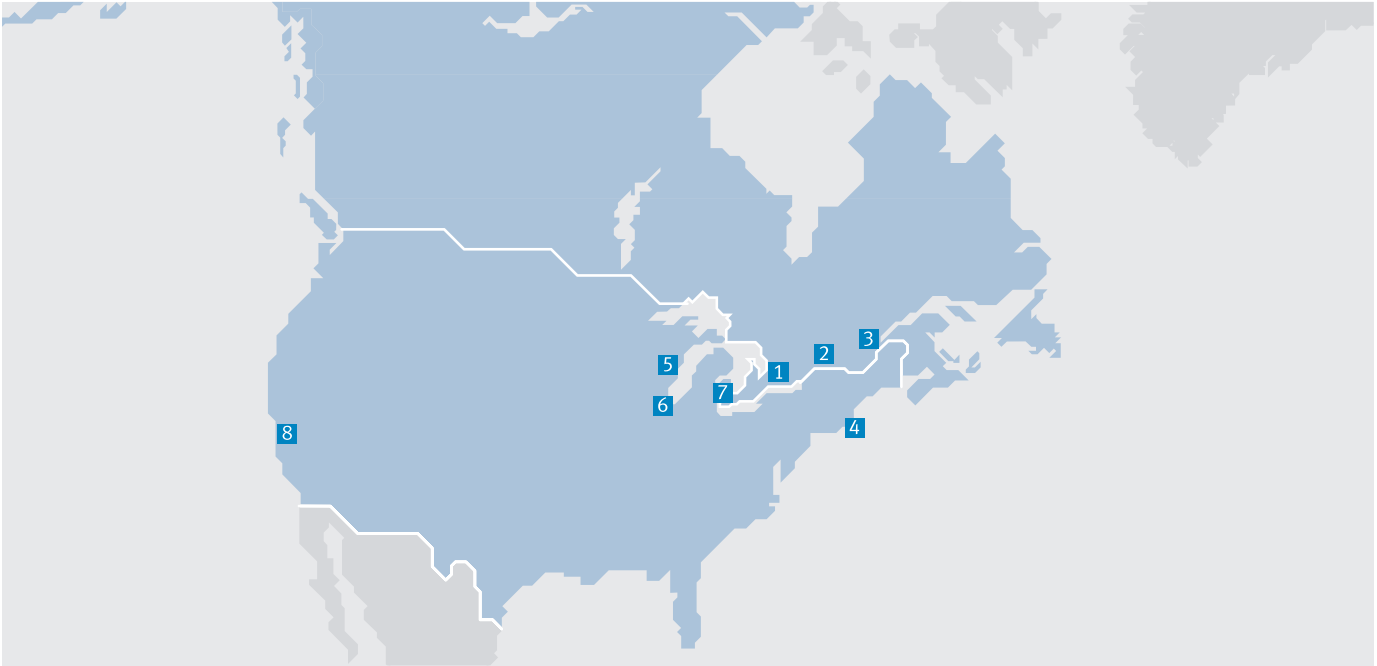

**1 Festo Canada
Headquarters
Festo Inc.**
5300 Explorer Drive
Mississauga, ON
L4W 5G4

2 Montréal
5600, Trans-Canada
Pointe-Claire, QC
H9R 1B6

3 Québec City
2930, rue Watt#117
Québec, QC
G1X 4G3



**4 Festo United States
Headquarters
Festo Corporation**
395 Moreland Road
Hauppauge, NY
11788

5 Appleton
North 922 Tower View Drive, Suite N
Greenville, WI
54942

7 Detroit
1441 West Long Lake Road
Troy, MI
48098

6 Chicago
85 W Algonquin - Suite 340
Arlington Heights, IL
60005

8 Silicon Valley
4935 Southfront Road, Suite F
Livermore, CA
94550

Festo Regional Contact Center

Canadian Customers

Commercial Support:
Tel: 1 877 GO FESTO (1 877 463 3786)
Fax: 1 877 FX FESTO (1 877 393 3786)
Email: festo.canada@ca.festo.com

Technical Support:

Tel: 1 866 GO FESTO (1 866 463 3786)
Fax: 1 877 FX FESTO (1 877 393 3786)
Email: technical.support@ca.festo.com

USA Customers

Commercial Support:
Tel: 1 800 99 FESTO (1 800 993 3786)
Fax: 1 800 96 FESTO (1 800 963 3786)
Email: customer.service@us.festo.com

Technical Support:

Tel: 1 866 GO FESTO (1 866 463 3786)
Fax: 1 800 96 FESTO (1 800 963 3786)
Email: product.support@us.festo.com