

Service unit combinations MSE6, MSE series



Service unit combinations MSE6, MSE series

Key features

Overview

Product description

The MSE6-E2M is an intelligent pneumatic service unit for optimising the use of compressed air as an energy medium in industrial automation technology.

Equipped with measurement, control and diagnostic functions, the

MSE6-E2M supports energy-efficient operation of pneumatic systems. The MSE6-E2M detects increased compressed air consumption in the standard production cycle which may be caused by leakages, for example, and enables targeted system

maintenance. Furthermore, the MSE6-E2M detects when the production plant is in a standby state and stops the supply of compressed air in order to prevent unnecessary compressed air consumption.

The MSE6-E2M can also be used as a process monitoring module by enabling flow and pressure values to be transferred directly to the machine controller via a fieldbus connection, where they can be analysed.

Product features

Control function (energy efficiency function)

- Automatic shut-off when flow rate is not achieved
- User-controlled shut-off and pressurising

Recording and provision of measurement data

- Output pressure
- Pressure change (for pressure tightness testing)
- Flow
- Air consumption

Limit monitoring

- Pressure, upper limit value
- Pressure change, upper limit value
- Flow, upper limit value

Fieldbus connection

- PROFIBUS

Installation

The module is typically assembled behind a service unit combination.

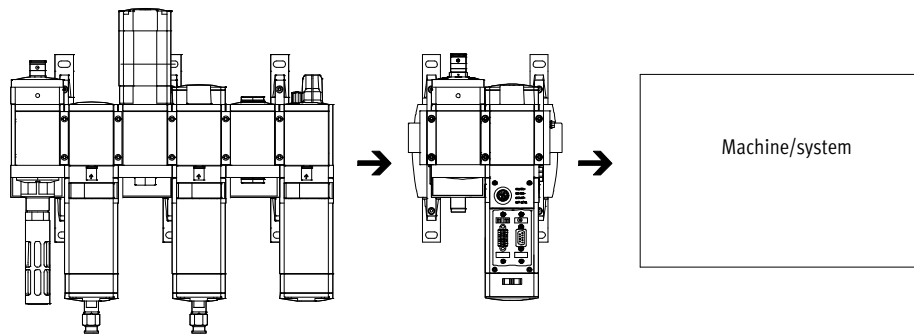

Structure

The main components of the MSE6-E2M are: shut-off valve, flow sensor, pressure sensor and bus node. The fieldbus interface allows complete integration into a machine controller. As an alternative to networked communication, the MSE6-E2M can also be operated using an external operator unit or a PC.

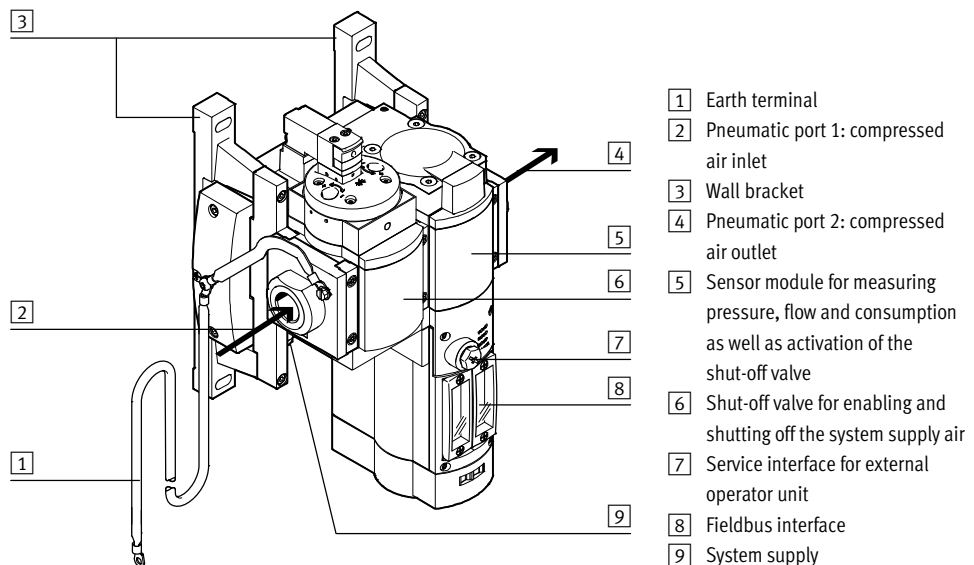

Service unit combinations MSE6, MSE series

Key features

Functions

Standby detection and automatic shut-off of the compressed air supply

The MSE6-E2M uses settable parameters to detect when the production system is down. The system is separated from the compressed air supply using a 2/2-way shut-off valve, without exhausting the downstream system. This avoids additional air consumption through leakages. If production is to continue on the

system, then this must be signalled to the MSE6-E2M. The shut-off valve opens and the system is again supplied with compressed air. Automatic shut-off of the compressed air supply can be activated and deactivated by the user. In the deactivated state, the shut-off valve can be controlled directly by the PLC.

Pressure tightness testing

When in the shut-off state, the MSE6-E2M measures the pressure curve over time. Even in well-maintained systems, the pressure falls continuously due to leakages. The fewer leakages the system has, the slower the pressure

drop will be. The measured pressure change serves as a measure of the leakage existing in the system. If the parameterised limit value is exceeded, then the device will output a diagnostic message.

Pressure recording

The MSE6-E2M continuously measures the output pressure, prepares the data and makes it available cyclically. To detect high operating pressures, the MSE6-E2M offers the option of parameterising limit values for pressure. If the parameterised limit value is exceeded, then the device will output a diagnostic message.

Flow recording

The MSE6-E2M continuously records the flow, prepares the data and makes it available cyclically. To detect high flow rates, the MSE6-E2M offers the option of parameterising limit values for the flow. If the parameterised limit value is exceeded, then the device will output a diagnostic message.

Consumption recording

The MSE6-E2M determines the compressed air consumption by recording the system flow rate. The user has the option of using appropriate signalling to record the compressed air consumption over a specific period of time.

Note

If there is an error (e.g. fieldbus interruption, PLC failure, no voltage) on the MSE6-E2M, then the 2/2-way shut-off valve switches to the initial position (pressurise). If there is a

shut-off valve upstream, the system is pressurised suddenly. Use suitable counter measures to prevent unintentional pressurisation of the system in the event of an error.

Service unit combinations MSE6, MSE series

Peripherals overview and type codes

Peripherals overview

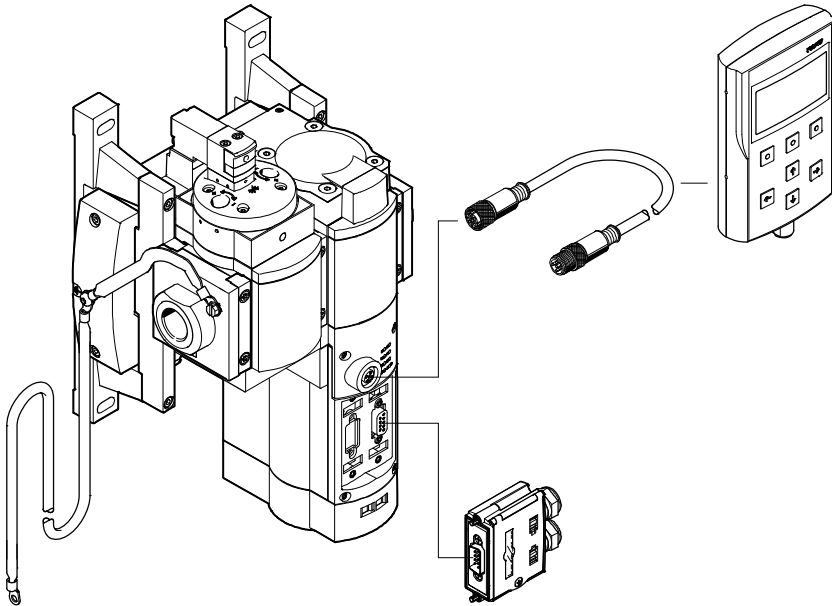

Accessories		→ Page/Internet
1	Operator unit CPX-MMI-1	8
2	Connecting cable KV-M12-M12	8
3	Plug FBS-SUB-9	8

Type codes

		MSE	6	-	E2M	-	5000	-	FB13	-	AGD
Series		MSE	Modular standard, electric								
Size		6	Grid dimension 62 mm								
Function		E2M	Energy saving (2/2-way function DE, V24)								
Flow measuring range		5000	5000 l/min								
Electrical actuation/inputs and outputs		FB13	Bus node for PROFIBUS DP								
Pneumatic connection		AGD	Connecting plate G1/2								

Service unit combinations MSE6, MSE series

Technical data

MSE6-E2M

consisting of

- Energy efficiency module
 - 2/2-way shut-off valve, open, single-solenoid
 - Flow sensor
 - Pressure sensor for output pressure
 - Control unit for processing measuring data, activating valves and controlling energy efficiency functions
- Fieldbus node

 - Operating pressure
4 ... 10 bar

 - Temperature range
0 ... +50 °C



General technical data	
Pneumatic connection 1, 2	G $\frac{1}{2}$ (connecting plate)
Mounting position	Horizontal $\pm 5^\circ$
Flow direction	Unidirectional P1 \rightarrow P2
Valve function	2/2-way shut-off valve, open, single-solenoid
Reset method	Mechanical

Electrical data	
System supply	
Electrical connection	Plug M18x1, 4-pin
Operating voltage range for actuator technology [V DC]	18 ... 26.4
Operating voltage range for electronics/sensors [V DC]	18 ... 30
Current consumption for actuator technology [mA]	Max. 100 when valve is fed with current
Current consumption for electronics/sensors at 24 V [mA]	Max. 300
Protection against incorrect polarity	For operating voltage connection
Degree of protection	IP65 with plug socket
Duty cycle [%]	100
Fieldbus connection	
Fieldbus interface	Sub-D socket, 9-pin

Standard nominal flow rate q_{nN1}	
Pneumatic port	G $\frac{1}{2}$
In main flow direction 1 \rightarrow 2 [l/min.]	4500

1) Measured at $p_1 = 6$ bar and $p_2 = 5$ bar, $\Delta p = 1$ bar

Service unit combinations MSE6, MSE series

Technical data

Operating and environmental conditions		
Operating pressure	[bar]	4 ... 10
Operating medium		Compressed air to ISO 8573-1:2010 [7:4:4]
Note on operating/pilot medium		Lubricated operation not possible
Ambient temperature	[°C]	0 ... +50
Temperature of medium	[°C]	0 ... +50
Storage temperature	[°C]	-10 ... +60
Corrosion resistance class CRC ¹⁾		2
CE marking		To EU EMC Directive ²⁾
(see declaration of conformity)		To EU Low Voltage Directive

- 1) Corrosion resistance class CRC 2 to Festo standard FN 940070
Moderate corrosion stress. Indoor applications in which condensation may occur. External visible parts with primarily decorative requirements for the surface and which are in direct contact with the ambient atmosphere typical for industrial applications.
- 2) For information about the applicability of the component see the manufacturer's EC declaration of conformity at: www.festo.com/sp → User documentation.
If the component is subject to restrictions on usage in residential, office or commercial environments or small businesses, further measures to reduce the emitted interference may be necessary.

Display/operation		
Flow measurement		
Flow measurement range	[l/min.]	50
initial value		
Flow measurement range final	[l/min.]	5000
value		
Accuracy of flow rate		+/- (3% o.m.v. + 0.3% FS) ¹⁾
Displayable unit(s)		l/min (presetting)
		scfm
Pressure measurement		
Pressure measuring range	[bar]	0
starting value		
Pressure measuring range	[bar]	14
final value		
Accuracy FS ¹⁾	[%]	3
Displayable unit(s)		mbar (presetting)
		kPa
		psi
Consumption measurement		
Displayable unit(s)		l (presetting)
		m ³
		scf

- 1) % FS = % of measuring range final value (full scale)

Weight [g]	
MSE6	3300

Materials	
Housing	Die-cast aluminium
Cap	Reinforced PA
Cover	Reinforced PA
Seals	Nitrile rubber
Note on materials	Contains PWIS (paint-wetting impairment substances)

Service unit combinations MSE6, MSE series

Technical data

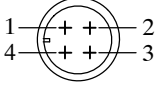
Pin allocation, system supply		
Plug M18x1, 4-pin	Pin	Meaning
	1	Operating voltage for electronics/sensors +24 V DC
	2	Operating voltage for actuator technology +24 V DC
	3	0 V
	4	Functional earth

Dimensions Download CAD data → www.festo.com

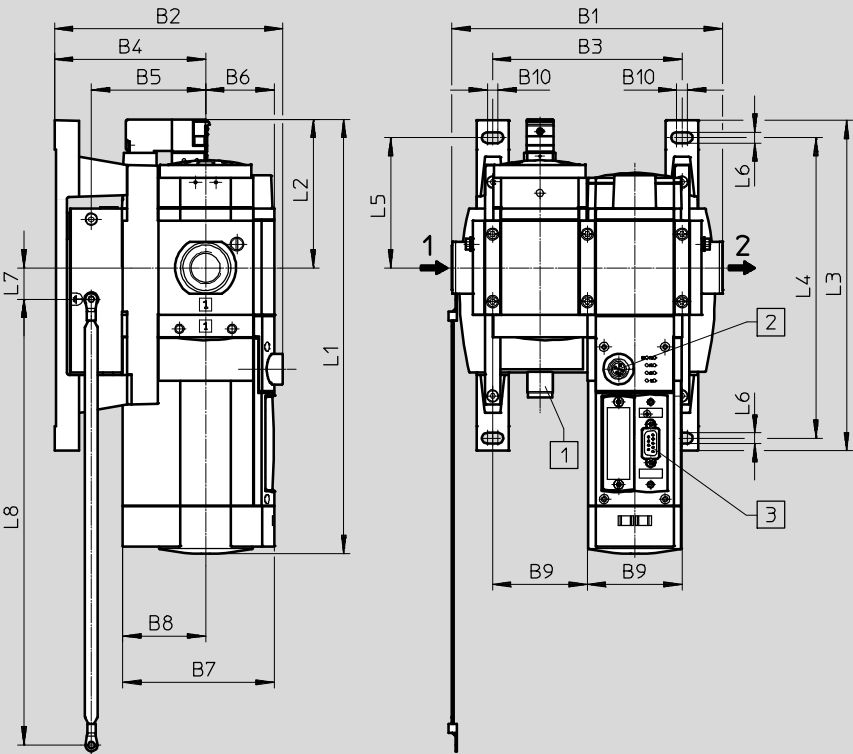

- 1 Plug M18x1, 4-pin
- 2 Socket M12x1, 5-pin
- 3 Sub-D socket, 9-pin

→ Flow direction

B1	B2	B3	B4	B5	B6	B7	B8	B9	B10	L1	L2	L3	L4	L5	L6	L7	L8
177.2	149.5	124	99	74.9	45	99.3	54.3	62	7	284.6	97.3	216.6	196.9	85.3	7	20.7	292

Ordering data			
Size	Pneumatic port	Part No.	Type
MSE6	G½	2465321	MSE6-E2M-5000-FB13-AGD

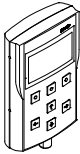

Service unit combinations MSE6, MSE series

Accessories

Ordering data – Operator unit CPX-MMI-1		Technical data → Internet: cpx-mmi-1	
Description		Part No.	Type
	Provides data polling, configuration and diagnostic functions	529043	CPX-MMI-1

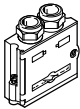
Ordering data – Connecting cable KV-M12-M12		Technical data → Internet: kv-m12-m12	
Description	Cable length [m]	Part No.	Type
	Connecting cable for operator unit CPX-MMI-1	529044	KV-M12-M12-1,5
		530901	KV-M12-M12-3,5

Ordering data – Plug FBS-SUB-9		Technical data → Internet: fbs-sub-9	
Description		Part No.	Type
	For PROFIBUS, Sub-D plug, straight	532216	FBS-SUB-9-GS-DP-B

Ordering data – Plug socket NTSD			Technical data → Internet: ntstd	
Description	Cable gland fitting	Terminal cross-section [mm ²]	Part No.	Type
	Pg9	1.5	18493	NTSD-GD-9
	Pg13	2.5	18526	NTSD-GD-13,5
	Pg9	1.5	18527	NTSD-WD-9

Product Range and Company Overview

A Complete Suite and Company Overview

Our experienced engineers provide complete support at every stage of your development process, including: conceptualization, analysis, engineering, design, assembly, documentation, validation, and production.



Custom Automation Components
Complete custom engineered solutions

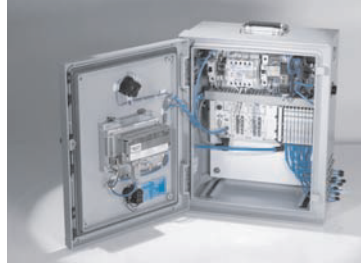

Custom Control Cabinets
Comprehensive engineering support and on-site services



Complete Systems
Shipment, stocking and storage services

The Broadest Range of Automation Components

With a comprehensive line of more than 30,000 automation components, Festo is capable of solving the most complex automation requirements.



Electromechanical
Electromechanical actuators, motors, controllers & drivers



Pneumatics
Pneumatic linear and rotary actuators, valves, and air supply



PLCs and I/O Devices
PLC's, operator interfaces, sensors and I/O devices

Supporting Advanced Automation... As No One Else Can!

Festo is a leading global manufacturer of pneumatic and electromechanical systems, components and controls for industrial automation, with more than 16,000 employees in 60 national headquarters serving more than 180 countries. For more than 80 years, Festo has continuously elevated the state of manufacturing with innovations and optimized motion control solutions that deliver higher performing, more profitable automated manufacturing and processing equipment. Our dedication to the advancement of automation extends beyond technology to the education and development of current and future automation and robotics designers with simulation tools, teaching programs, and on-site services.

Quality Assurance, ISO 9001 and ISO 14001 Certifications

Festo Corporation is committed to supply all Festo products and services that will meet or exceed our customers' requirements in product quality, delivery, customer service and satisfaction.

To meet this commitment, we strive to ensure a consistent, integrated, and systematic approach to management that will meet or exceed the requirements of the ISO 9001 standard for Quality Management and the ISO 14001 standard for Environmental Management.



© Copyright 2013, Festo Corporation. While every effort is made to ensure that all dimensions and specifications are correct, Festo cannot guarantee that publications are completely free of any error, in particular typing or printing errors. Accordingly, Festo cannot be held responsible for the same. For Liability and Warranty conditions, refer to our "Terms and Conditions of Sale", available from your local Festo office. All rights reserved. No part of this publication may be reproduced, distributed, or transmitted in any form or by any means, electronic, mechanical, photocopying or otherwise, without the prior written permission of Festo. All technical data subject to change according to technical update.



Printed on recycled paper at New Horizon Graphic, Inc., FSC certified as an environmental friendly printing plant.

Festo North America

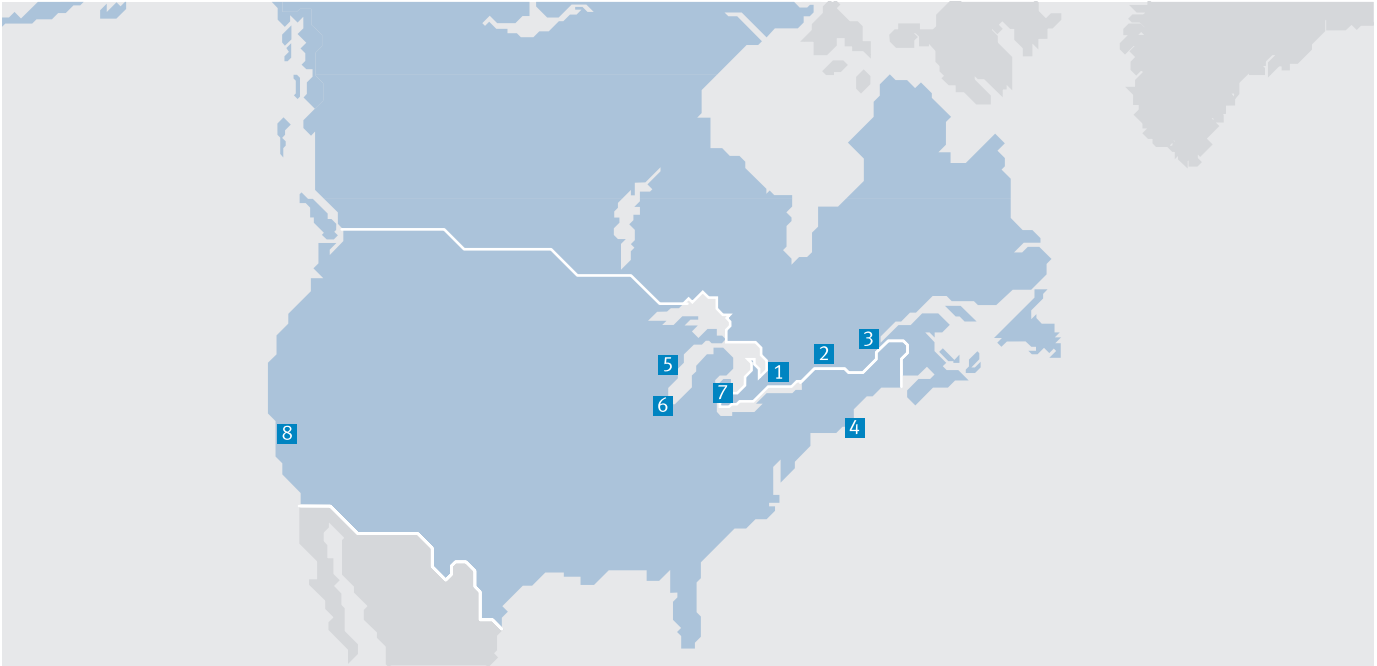

**1 Festo Canada
Headquarters
Festo Inc.**
5300 Explorer Drive
Mississauga, ON
L4W 5G4

2 Montréal
5600, Trans-Canada
Pointe-Claire, QC
H9R 1B6

3 Québec City
2930, rue Watt#117
Québec, QC
G1X 4G3



**4 Festo United States
Headquarters
Festo Corporation**
395 Moreland Road
Hauppauge, NY
11788

5 Appleton
North 922 Tower View Drive, Suite N
Greenville, WI
54942

7 Detroit
1441 West Long Lake Road
Troy, MI
48098

6 Chicago
85 W Algonquin - Suite 340
Arlington Heights, IL
60005

8 Silicon Valley
4935 Southfront Road, Suite F
Livermore, CA
94550

Festo Regional Contact Center

Canadian Customers

Commercial Support:
Tel: 1 877 GO FESTO (1 877 463 3786)
Fax: 1 877 FX FESTO (1 877 393 3786)
Email: festo.canada@ca.festo.com

Technical Support:
Tel: 1 866 GO FESTO (1 866 463 3786)
Fax: 1 877 FX FESTO (1 877 393 3786)
Email: technical.support@ca.festo.com

USA Customers

Commercial Support:
Tel: 1 800 99 FESTO (1 800 993 3786)
Fax: 1 800 96 FESTO (1 800 963 3786)
Email: customer.service@us.festo.com

Technical Support:
Tel: 1 866 GO FESTO (1 866 463 3786)
Fax: 1 800 96 FESTO (1 800 963 3786)
Email: product.support@us.festo.com

Subject to change

Internet: www.festo.com/us