

Handling modules HSP



# Handling modules HSP

Key features at a glance

## Field of application

The handling module is a new generation of function modules for the automatic transfer, feed and removal of small parts in extremely confined spaces.

This is achieved by means of a guided vertical and horizontal motion sequence. A backlash-free cross-guide

with recirculating ball bearing elements ensures high precision and good rigidity.

The combination of a semi-rotary drive and a slotted guide system produces a compact unit for a complete pick and place cycle.

## Special features

- Compact design
- Extremely short cycle times
- Low cost
- Simple commissioning
- For working loads up to 1.6 kg
- Stroke adjustment along Y- and Z-axes
- Wait positions possible
- No planning costs

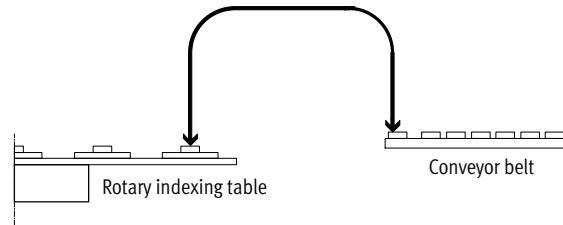

## Three drive variants are available

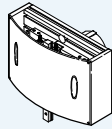
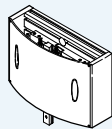
		Pneumatic: HSP-...-AP, with swivel module DSM	Without drive: HSP-...-AS, with drive shaft
			
<b>Advantages</b>			
		<ul style="list-style-type: none"> <li>• Fast</li> <li>• Cost-effective</li> <li>• Ready to install</li> <li>• No system planning required</li> <li>• Simple commissioning</li> </ul>	<ul style="list-style-type: none"> <li>• Compact</li> <li>• Universal compatibility</li> <li>• Variable drive interface</li> <li>• On request: Drive options in combination with servo motors EMMS-AS</li> </ul>
<b>Technical data</b>			
Stroke	Y [mm]	52 ... 170	
	Z [mm]	20 ... 70	
Min. cycle time	[s]	0.6 ... 1.0	Depends on drive
Working load	[g]	0 ... 1600	
Repetition accuracy at end positions	[mm]	±0.02	
Wait positions		Max. 2	Depends on drive
Function of wait position		Pulling with return cylinder	Depends on drive
Repetition accuracy at wait positions	[mm]	< 1	Depends on drive
Data sheet		→ 8	→ 18

# Handling modules HSP

Typical applications

FESTO

## HSP...-AP, pneumatic

Linear transfer

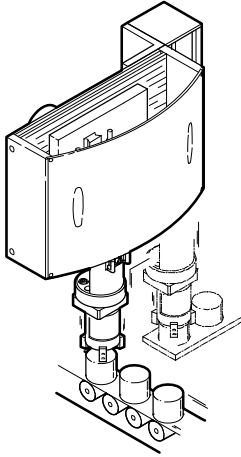

- Fast feed and removal, e.g. for linear transfer or rotary indexing table

Belt-type part positioning

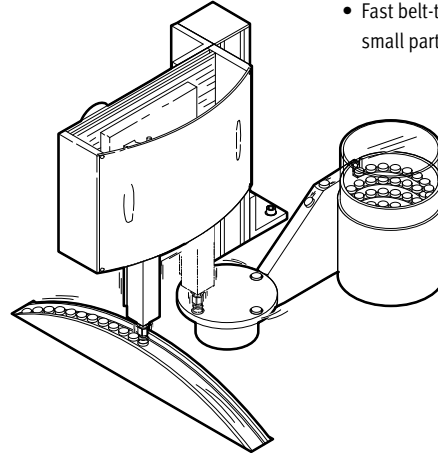

- Fast belt-type part positioning of small parts

## HSP...-AS, without drive

Linear transfer

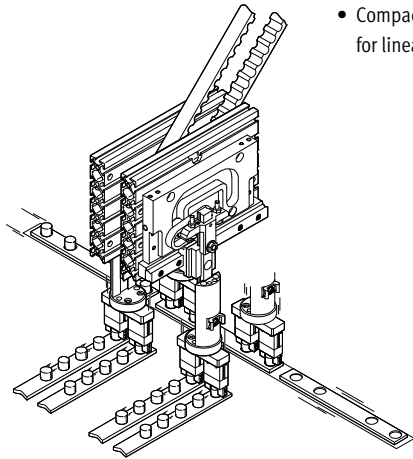

- Compact twin pick and place unit for linear transfer

Rotary indexing table, linear transfer

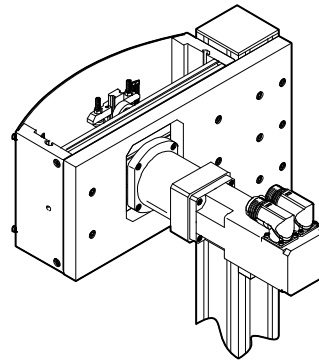

- Fast and flexible pick and place unit with servo motor EMMS-AS
- Electrical variant using third-party motor

# Handling modules HSP

Key features at a glance

## HSP...-AP – pneumatic with swivel module DSM

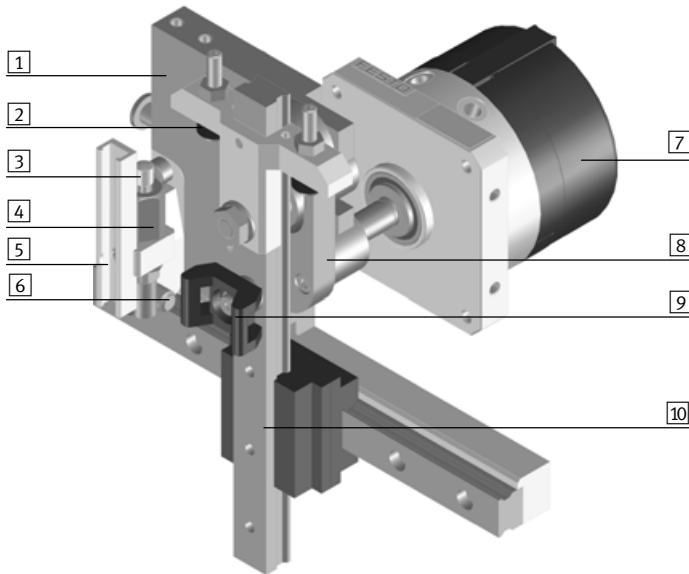

- 1 Slotted guide plate
- 2 Adjustable stop
- 3 Shock absorber YSRW
- 4 Stop sleeve
- 5 Sensor rail
- 6 Pressure piece
- 7 Swivel module DSM
- 8 Swivel lever
- 9 Cable binder holder
- 10 Cross-guide

## HSP...-AS – without drive (rear side)

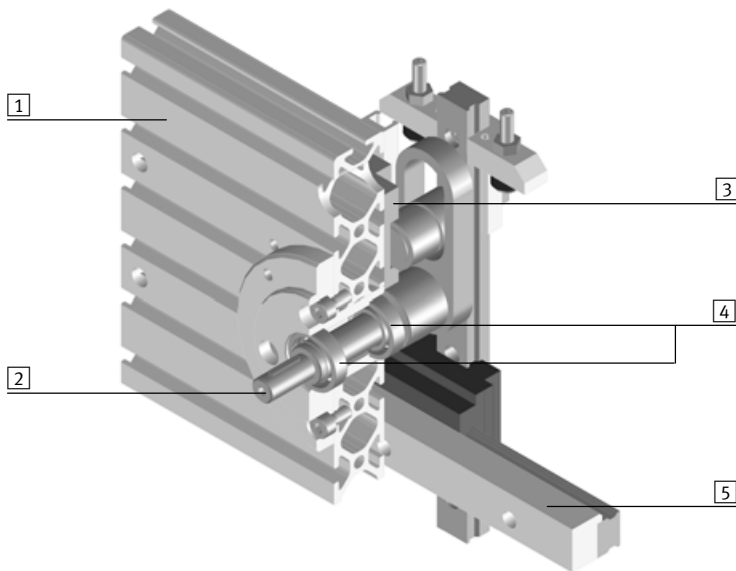

- 1 Back plate
- 2 Shaft with Woodruff key
- 3 Slotted guide plate
- 4 Ball bearings
- 5 Aluminium rail for alignment of slotted guide plates

# Handling modules HSP

Key features at a glance

FESTO

## The technology in detail

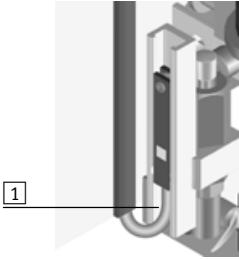

1

1 Proximity sensor cables are installed via profile slots in the side and back plate.

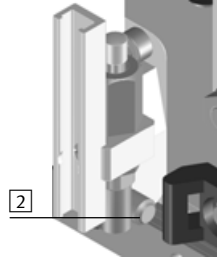

2

2 The pressure piece guarantees freedom from backlash and precision at the end positions and in the effective linear stroke along the Z-axis.

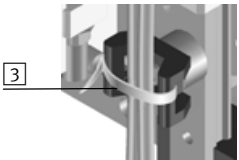

3

3 Cable binder holders facilitate the secure routing of tubing and cables.

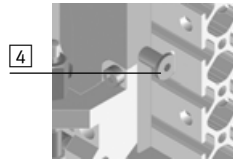

4

4 The adjustable slotted guide plate permits precise stroke setting.

# Handling modules HSP

Peripherals overview

FESTO

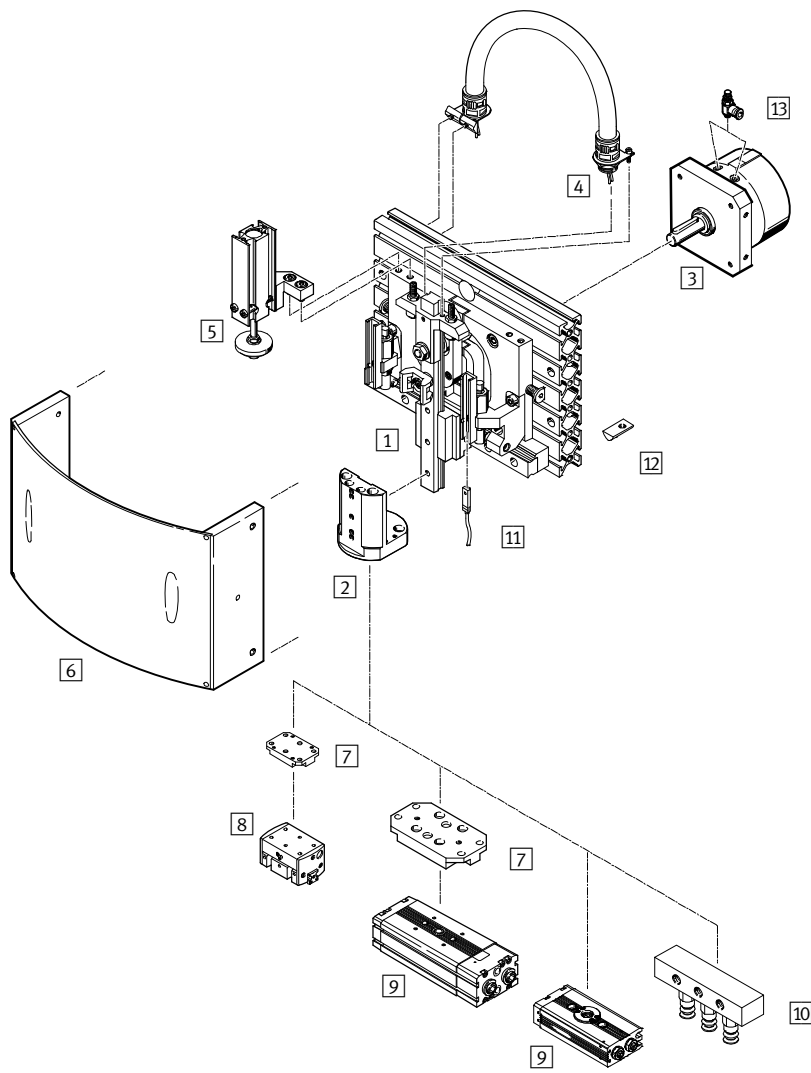

# Handling modules HSP

Peripherals overview

Accessories		
	Brief description	→ Page/Internet
1	Handling module HSP	Standard module without accessories 9
2	Adapter kit HAPG	Interface for grippers, semi-rotary drives, etc. 21
3	Swivel module DSM	Pneumatic drive, adapted to each size dsm
4	Installation kit MKRP	Conduit to protect electric cables and tubing 21
5	Wait position module BWL-/BWR-HSP	With pneumatic drive: Function for retracting the swivel arm from operating area 22
6	Cover kit BSD-HSP	To protect against accidental contact 22
7	Adapter kit	Interface between HSP and gripper or semi-rotary drive gripper drqd
8	Gripper	Parallel/Three-point/Radial/Angle gripper, appropriate gripper for every application gripper
9	Semi-rotary drive DRQD	Semi-rotary drive for transferring parts drqd
10	Suction cups	Appropriate suction cup for every application suction cup
11	Proximity sensor SME-/SMT-8	Sensing facility for end positions 23
12	Slot nut HMBN	Mounting element 23
13	Non-return and flow control valve GRLA	Speed setting of pneumatic drives gla

# Handling modules HSP, pneumatic

Type codes

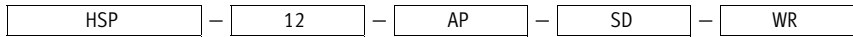

**Type**

HSP	Handling module, double-acting
-----	--------------------------------

**Size**

**Drive**

AP	Pneumatic drive
----	-----------------

**Function**

SD	Protective cover
----	------------------

**Function**

WR	Wait position on right
WL	Wait position on left



# Handling modules HSP, pneumatic

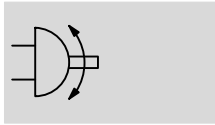

Technical data

Function

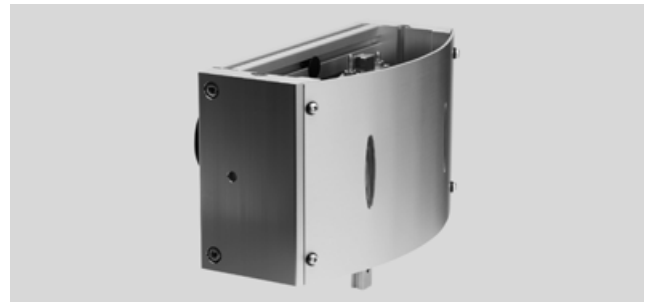

 [www.festo.com](http://www.festo.com)



-  Size  
12, 16 and 25
-  Y-stroke length  
52 ... 170
-  Z-stroke length  
20 ... 70

General technical data	
Type	HSP...-AP
Pneumatic connection	M5
Mode of operation	Double-acting
Operating medium	Compressed air in accordance with ISO 8573-1:2010 [7:-:-]
Note on operating/pilot medium	Operation with lubricated medium possible (in which case lubricated operation will always be required)
Constructional design	Swivel module
	Cross-guide
	Guided motion sequence
Cushioning	Shock absorber at both ends, soft characteristic curve
Position sensing	For proximity sensing
Type of mounting	With through-holes
	With slot nuts
Mounting position	Guide rail, vertical/horizontal

Operating and environmental conditions	
Type	HSP...-AP
Operating pressure [bar]	4 ... 8
Ambient temperature [°C]	0 ... +60

Stroke [mm]				
Size		12	16	25
Y-axis				
Stroke		52 ... 68	90 ... 110	130 ... 170
Z-axis				
Stroke	Z	20 ... 30	35 ... 50	50 ... 70
Working stroke	Za	5 ... 15	5 ... 20	5 ... 25

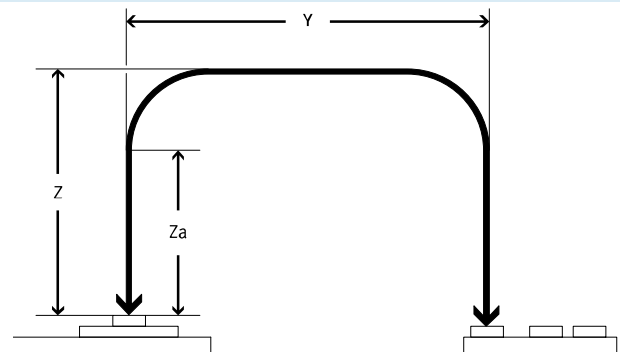

Forces [N]			
Size	12	16	25
Z-axis			
Effective force at 6 bar	40	50	65
Y-axis			
Permissible process force	30	35	50

# Handling modules HSP, pneumatic

Technical data

Weight [g]			
Size	12	16	25
HSP-...-AP	1,900	3,300	6,400
HSP-...-AP-SD	2,600	4,600	7,600
HSP-...-AP-SD-WR	2,800	4,800	8,100
HSP-...-AP-SD-WL	2,800	4,800	8,100

## Repetition accuracy [mm]

To ensure low-vibration operation, the working load should be mounted as close as possible to the guide rail of the handling module. Repetition accuracy is guaranteed by

mounting the working load (adapter plate, rotary drive and/or gripper, gripper finger, workpiece) within the mounting surface of the adapter kit HAPG.

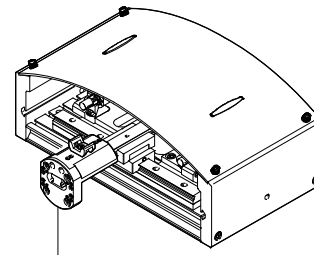

Mounting surface of HAPG

Size	12	16	25
Repetition accuracy at end positions	±0.01	±0.01	±0.02

## Travel times t as a function of working load m

The travel time t is the time taken for the handling module to move from one end position to the other and back again.

The working load m is the load attached to the vertical guide rail (e.g. adapter, gripper, semi-rotary drive and workpiece).

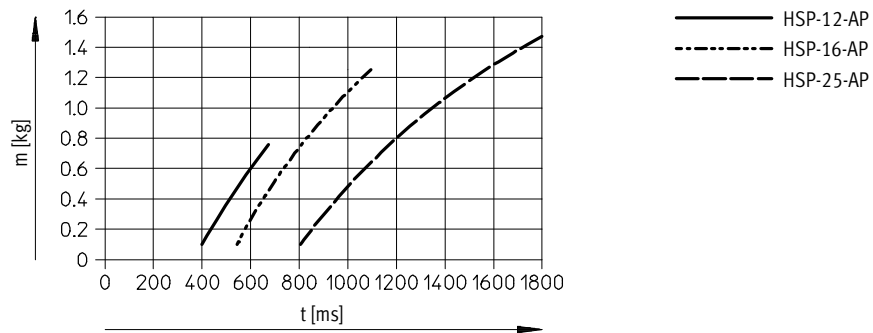

## Cycle times [s]

The cycle time  $t_t$  comprises the travel time t and the dwell time  $t_e$  at the end positions.

$t_t = \text{travel time } t + \text{dwell time } t_e$   
The value must not fall below the minimum cycle time.

Size	12	16	25
Min. cycle time	0.6	0.8	1.0

## Example for HSP-12-AP

Step 1:  
The following values are assumed:  
Working load  $m = 0.15 \text{ kg}$   
Dwell time  $t_e = 2 \times 50 \text{ ms}$   
(50 ms per end position)

Step 2:  
The travel time can be determined from the graph:  
 $t = 400 \text{ ms}$

Step 3:  
This gives us a cycle time:  
 $t_t = 400 \text{ ms} + 100 \text{ ms} = 500 \text{ ms}$

Step 4:  
The table gives us a min. cycle time of 600 ms. This means that the movement has to be controlled.

# Handling modules HSP, pneumatic

Technical data

## Permissible static/dynamic characteristic load values

Cross-guide

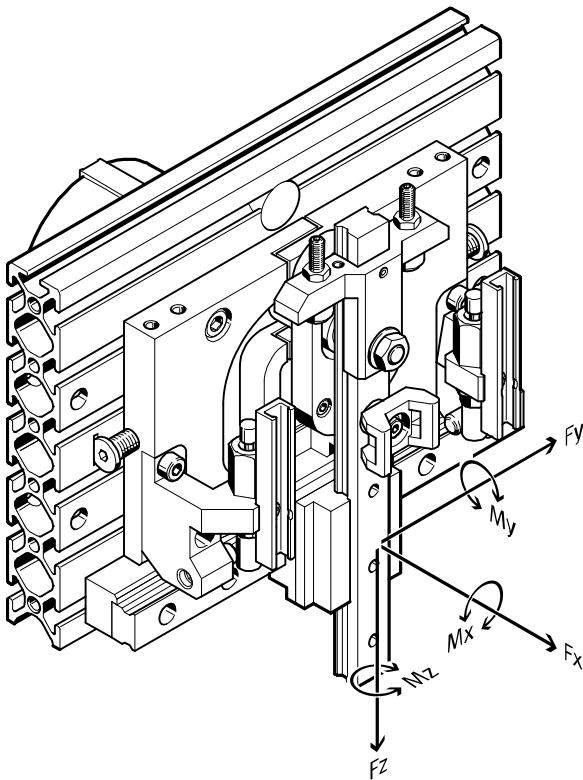

- - Note

The torques apply to the centre of the vertical guide.

### Combined load

The following torque equation must be satisfied with combined load:

$$\frac{M_x}{M_{xperm.}} + \frac{M_y}{M_{yperm.}} + \frac{M_z}{M_{zperm.}} \leq 1$$

Dynamic characteristic load values			
Size	12	16	25
Max. torques [Nm]	1.1	2.4	3.2
$M_{xperm.}, M_{yperm.}, M_{zperm.}$			

### Combined load

The following torque equation must be satisfied with combined load:

$$\frac{M_{ox}}{M_{oxperm.}} + \frac{M_{oy}}{M_{oyperm.}} + \frac{M_{oz}}{M_{ozperm.}}$$

Static characteristic load values			
Size	12	16	25
Max. torques [Nm]	5	10	15
$M_{oxperm.}, M_{oyperm.}, M_{ozperm.}$			

# Handling modules HSP, pneumatic

Technical data

FESTO

## Stroke adjustment

### Y stroke:

- Once the HSP has been mounted, the Y strokes of the pick and place position can be set independently of each other.

### Z stroke:

- Differences in height, for example between a rotary indexing table and a transfer system, can be compensated after mounting.

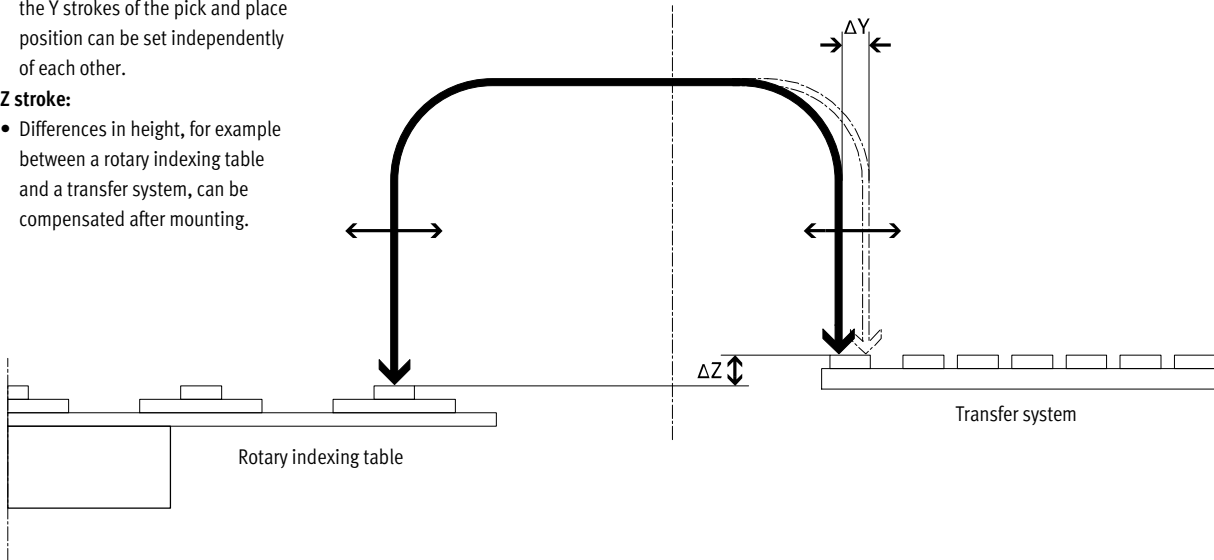

### Y-axis (horizontal)

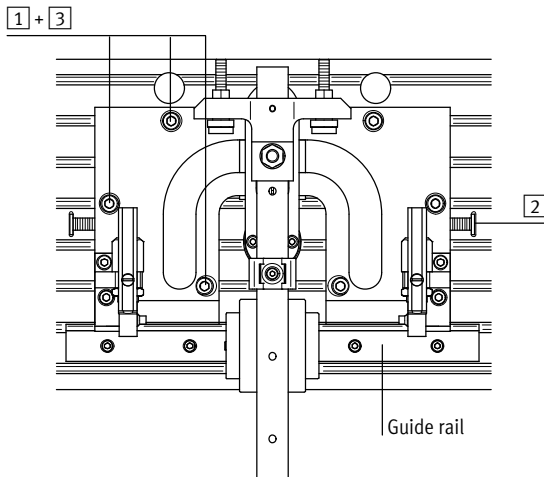

#### Procedure:

- Loosen the screws
- Adjust the slotted guide plate using the adjustment screw (the slotted guide plate must always make contact with the guide rail)
- Tighten the screws

### Z-axis (vertical)

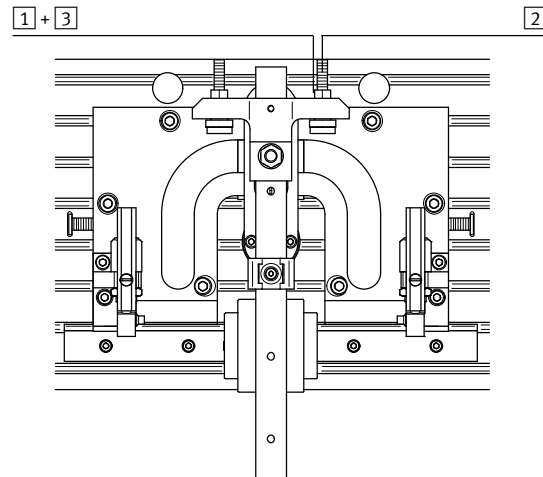

#### Procedure:

- Loosen the lock nut
- Set the desired Z stroke using the set screw
- Tighten the lock nut

# Handling modules HSP, pneumatic

Technical data

## Wait position module

Application and mode of operation

Figure 1:

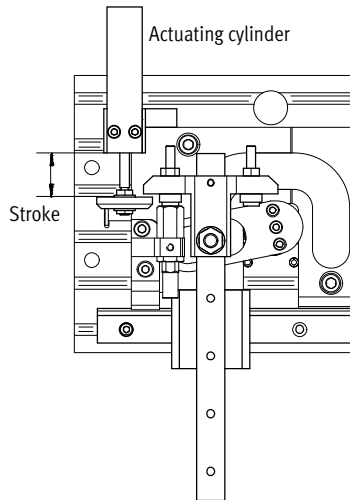
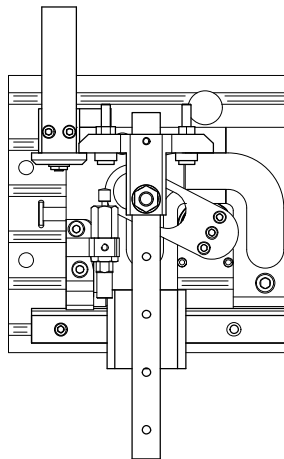
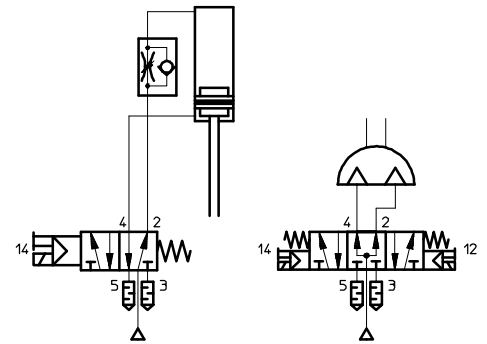

Figure 2:



Circuit diagram for HSP with wait position module



- 1 The handling module HSP is at the right-hand end position. The actuating cylinder is extended in its initial position.
- 2 The 5/3-way valve is reset once the handling module reaches the left-hand end position. (Figure 1)
- 3 During retraction, the actuating

cylinder pulls the handling module upwards to its wait position. The operating area is then free. (Figure 2)

- 4 From the wait position, the handling module can move either to the initial position or to the other end position.

Cycle

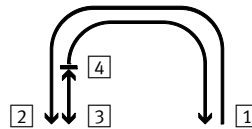

**Note**  
When used in combination with the wait position module, the handling module HSP must be actuated using a 5/3-way valve (normally pressurised). The actuating cylinder is actuated using a 5/2-way valve. The actuating cylinder may only be used for "pulling" applications.

Size	HSP-12	HSP-16	HSP-25
Max. Z stroke of wait position module	15	25	25

## Mounting options

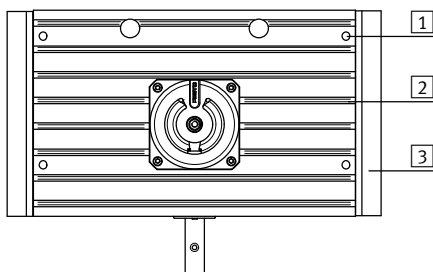

- 1 Direct mounting via through-holes
- 2 Via slot nuts
- 3 User-specific

## Examples:

With adapter kit HMBV

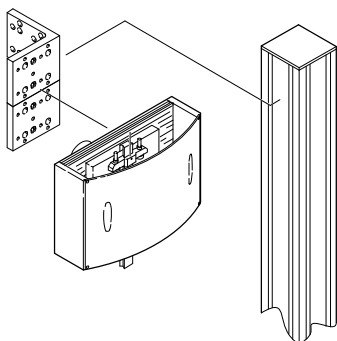

User-specific

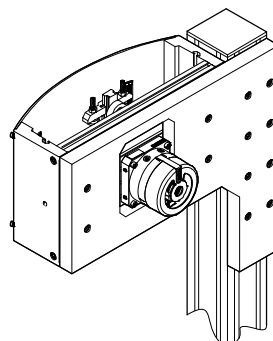

# Handling modules HSP, pneumatic

Technical data

FESTO

## Materials

Sectional view of handling module HSP

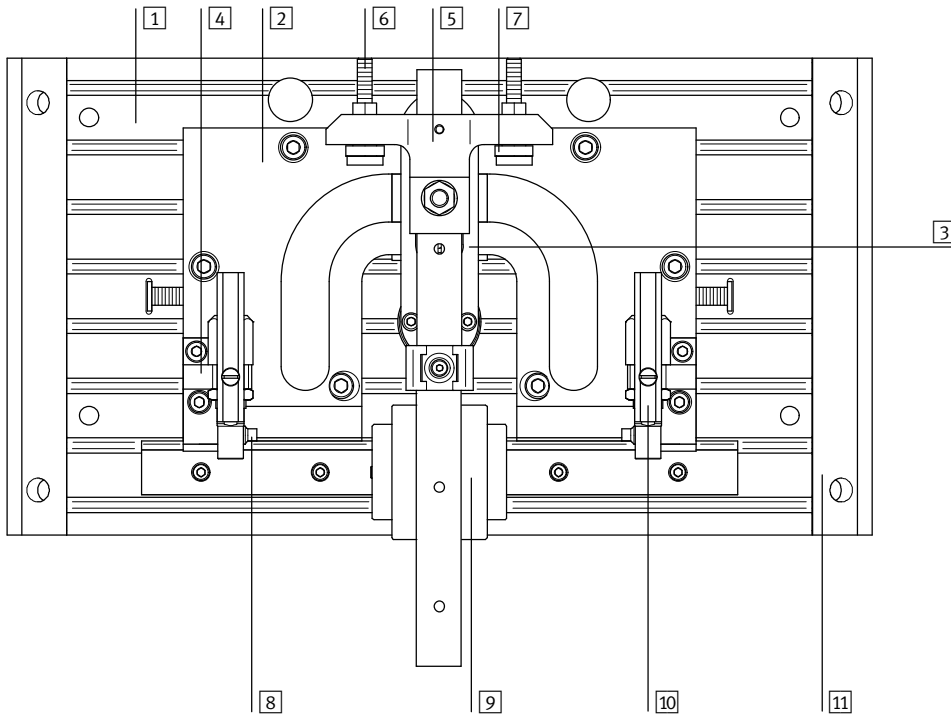

Handling module	
1	Back plate Wrought aluminium alloy, anodised
2	Slotted guide plate Case-hardened steel, burnished
3	Swivel lever Case-hardened steel, burnished
4	Retainer Wrought aluminium alloy, anodised
5	Flange Wrought aluminium alloy, anodised
6	Adjusting screw High-alloy steel
7	Stop sleeve High-alloy steel
8	Pressure piece High-alloy steel
9	Cross-guide Tempered steel
10	Sensor rail Wrought aluminium alloy, anodised
11	Housing Wrought aluminium alloy, anodised
Material note Copper and PTFE-free	

# Handling modules HSP, pneumatic

Technical data

## Materials

Sectional view of swivel module DSM

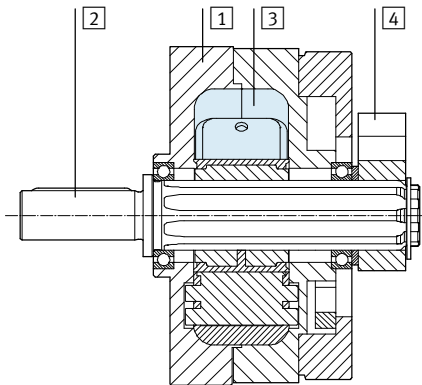

Swivel module		
1	Housing	Wrought aluminium alloy
2	Shaft	Steel with nickel-plated surface
3	Rotary vane	Fibreglass reinforced plastic
4	Stop lever	Anodised aluminium
-	Cap	Fibreglass reinforced plastic
-	Seals	Polyurethane
-	Material note	Copper and PTFE-free

# Handling modules HSP, pneumatic

Technical data

FESTO

## Dimensions

Download CAD data → [www.festo.com](http://www.festo.com)

With swivel module DSM

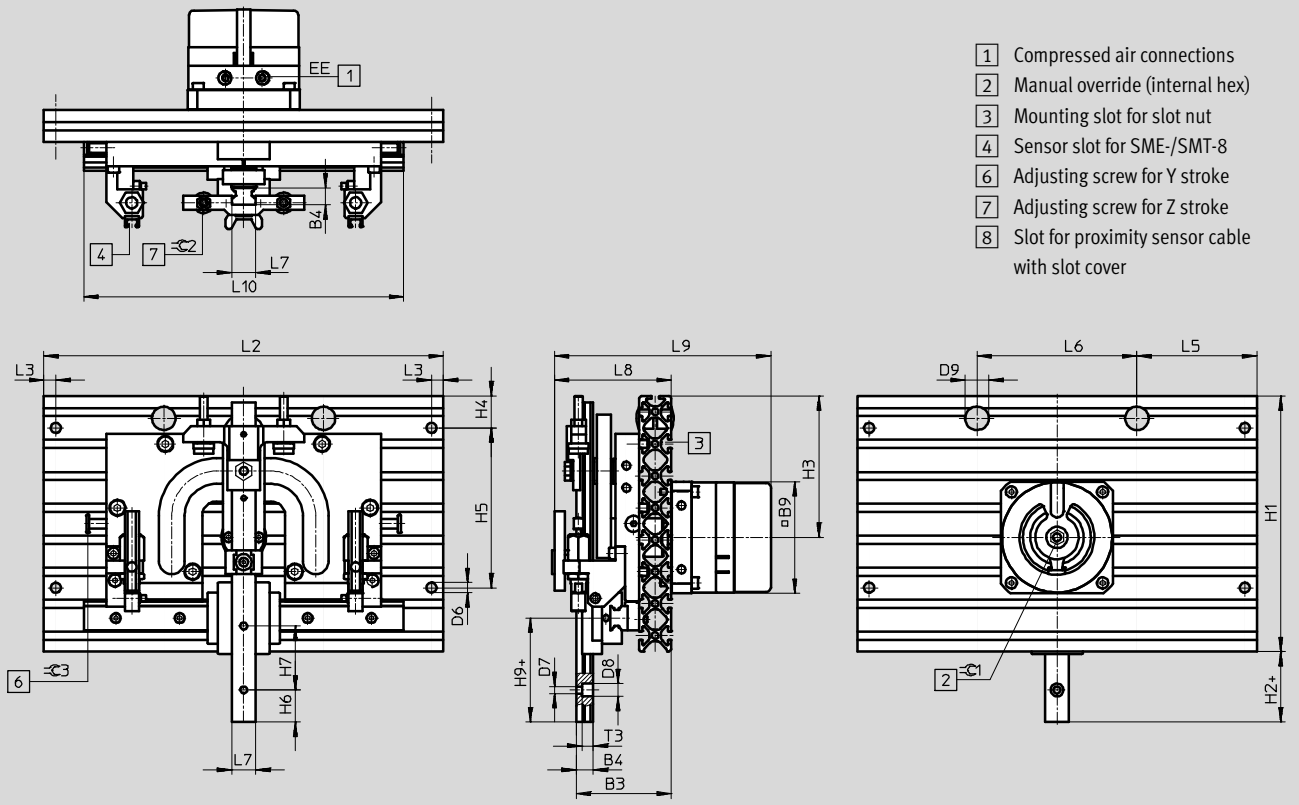

With swivel module DSM and protective cover

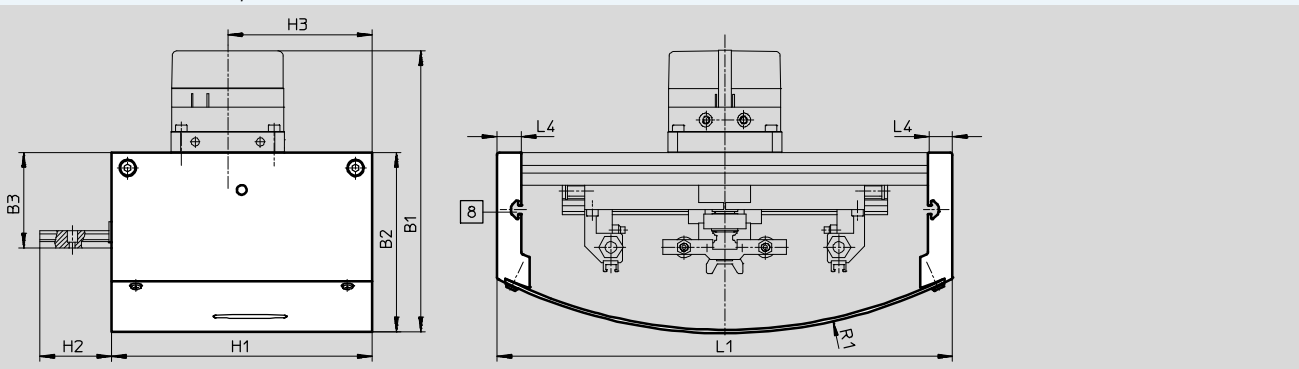

With wait position on right

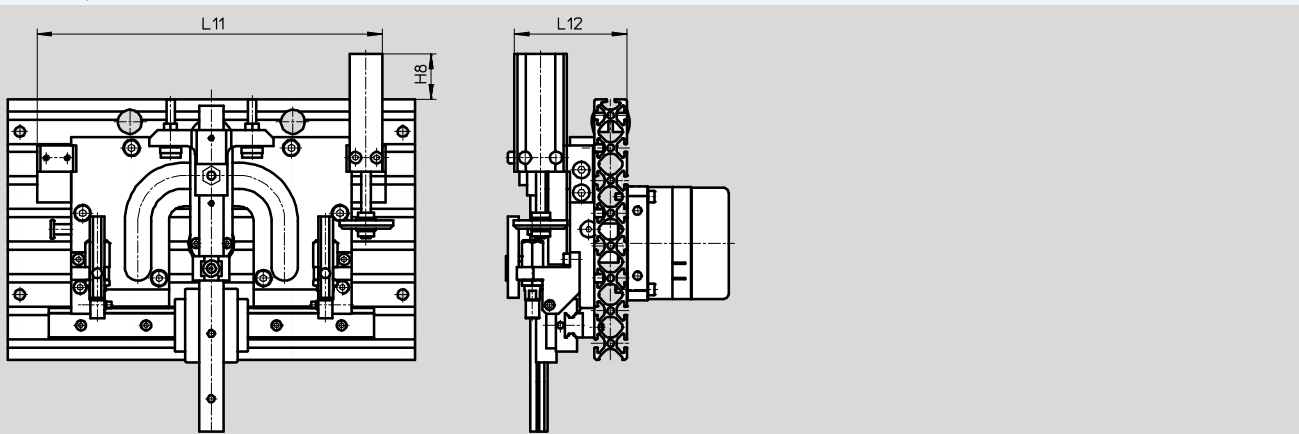



# Handling modules HSP, pneumatic

Technical data

Size	B1	B2	B3	B4	B9	D6 ∅	D7 ∅	D8 ∅	D9 ∅
	±3	±2	±0.5						
12	150	93	56	9 <sup>-0.03</sup>	56	6.3	3.5	6.2	13
16	179	111	60	10.6 <sup>-0.03</sup>	70	6.3	4.3	8	13
25	188	115	62	10 <sup>±0.05</sup>	83	6.3	4.5	10	13

Size	EE	H1	H2	H3	H4	H5	H6	H7	H8
			±0.2			±0.2			
12	M5	120	34	66	40	40	12.5	25	30
16	M5	160	44	88.5	20	100	20	40	33
25	M5	200	75	110	40	100	20	30	13

Size	H9	L1	L2	L3	L4	L5	L6	L7	L8
		±0.6	±0.2						±1.2
12	44	200	170	7.5	15	85	-	12 <sup>-0.01/-0.05</sup>	65
16	65	280	250	7.5	15	75	100	15 <sup>-0.01/-0.05</sup>	73
25	101	370	340	7.5	15	30	280	23.2 <sup>±0.05</sup>	80

Size	L9	L10	L11 <sup>1)</sup>	L12	R1	T3	≈C1	≈C2	≈C3
	±3								
12	122	150	141.5	64	200	6	6	2	3
16	142	200	210	69	306	6.5	8	2.5	3
25	153	250	277	79	484	6.3	8	2.5	4

1) If the Y stroke is increased, the change in stroke must be added to the dimension.

Ordering data for HSP-...-AP									
Size	12		16		25				
	Part No.	Type	Part No.	Type	Part No.	Type			
Without protective cover									
-	533599	HSP-12-AP	533607	HSP-16-AP	533615	HSP-25-AP			
Wait position on right	533603	HSP-12-AP-WR	533611	HSP-16-AP-WR	533619	HSP-25-AP-WR			
Wait position on left	533604	HSP-12-AP-WL	533612	HSP-16-AP-WL	533620	HSP-25-AP-WL			
With protective cover									
-	533600	HSP-12-AP-SD	533608	HSP-16-AP-SD	533616	HSP-25-AP-SD			
Wait position on right	533601	HSP-12-AP-SD-WR	533609	HSP-16-AP-SD-WR	533617	HSP-25-AP-SD-WR			
Wait position on left	533602	HSP-12-AP-SD-WL	533610	HSP-16-AP-SD-WL	533618	HSP-25-AP-SD-WL			

# Handling modules HSP, without drive

Type codes

		HSP	-	12	-	AS	-	SD
<b>Type</b>								
HSP	Handling module							
<b>Size</b>								
<b>Drive</b>								
AS	Drive shaft							
<b>Function</b>								
SD	Protective cover							

# Handling modules HSP, without drive

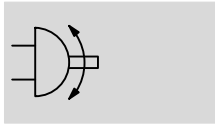

Technical data

Function



 www.festo.com





-  - Diameter  
12, 16 and 25
-  - Y-stroke length  
52 ... 170
-  - Z-stroke length  
20 ... 70

General technical data	
Type	HSP...-AS
Constructional design	Drive shaft
	Cross-guide
	Guided motion sequence
Cushioning	Noise reduction via buffers
Type of mounting	With through-holes
	With slot nuts
Mounting position	Guide rail, vertical/horizontal

Weight [g]			
Size	12	16	25
HSP...-AS	1800	3100	6200
HSP...-AS-SD	2500	4300	7400

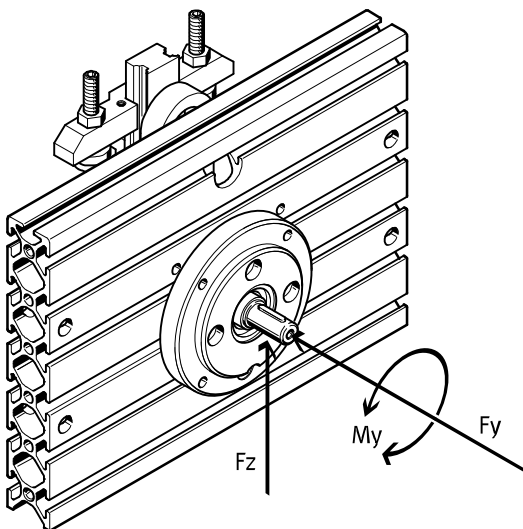
## Permissible static/dynamic characteristic load values



 Note  
Technical data for mechanical components → 11.

Characteristic load values			
Size	12	16	25
Max. axial force $F_{Yperm.}$	[N] 18	30	50
Max. radial force $F_{Zperm.}$	[N] 45	75	120
Max. drive torque $M_{Yperm.}$	[Nm] 1.25	2.5	5

# Handling modules HSP, without drive

Technical data

FESTO

## Mass moment of inertia $J_0$ as a function of working load $m$ (for cylinder sizing)

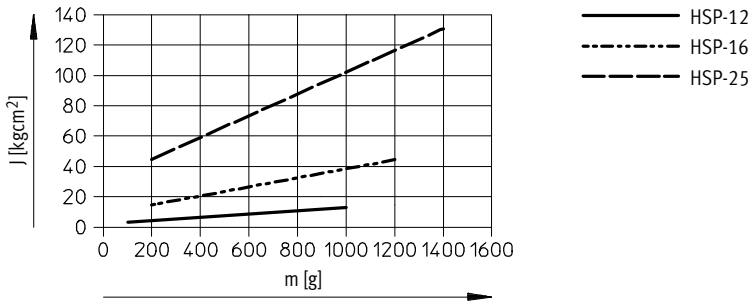

## Dimensions

Download CAD data → [www.festo.com](http://www.festo.com)

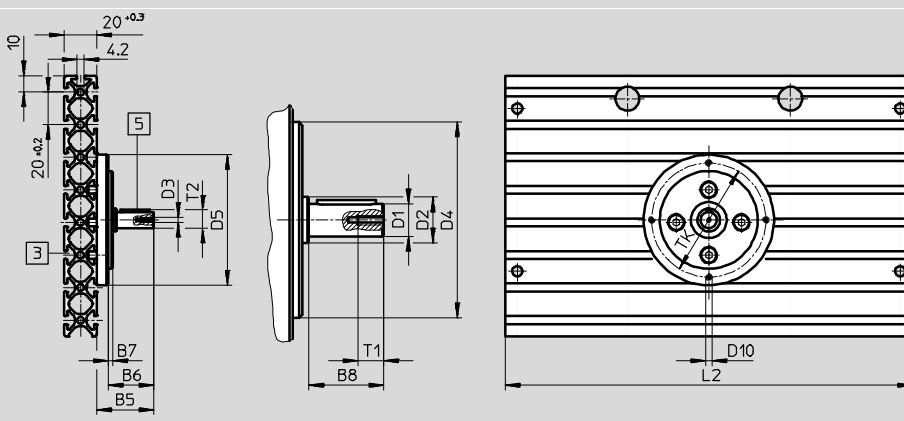

Basic dimensions

→ 16

- 3 Mounting slot for slot nut
- 5 Woodruff key

Size	B5	B6	B7	B8	D1 ∅ g7	D2 ∅	D3
12	29	22	3	17.5	8	12.5	M3
16	35	28	3	23	10	14	M3
25	44	36	4	30	12	17	M4

Size	D4 ∅ f8	D5 ∅	D10	L2	T1	T2 max.	TK ±0.1
12	45	65	M4	±0.2 170	9	8.8	55
16	60	80	M4	250	9	11.2	70
25	70	95	M5	340	10	13.5	82

## Ordering data for HSP-...-AS

Size	12		16		25	
	Part No.	Type	Part No.	Type	Part No.	Type
Without protective cover	533605	HSP-12-AS	533613	HSP-16-AS	533621	HSP-25-AS
With protective cover	533 06	HSP-12-AS-SD	533614	HSP-16-AS-SD	533622	HSP-25-AS-SD

# Handling modules HSP

Accessories

FESTO

## Adapter kit HAPG-B

Material:  
Wrought aluminium alloy, anodised

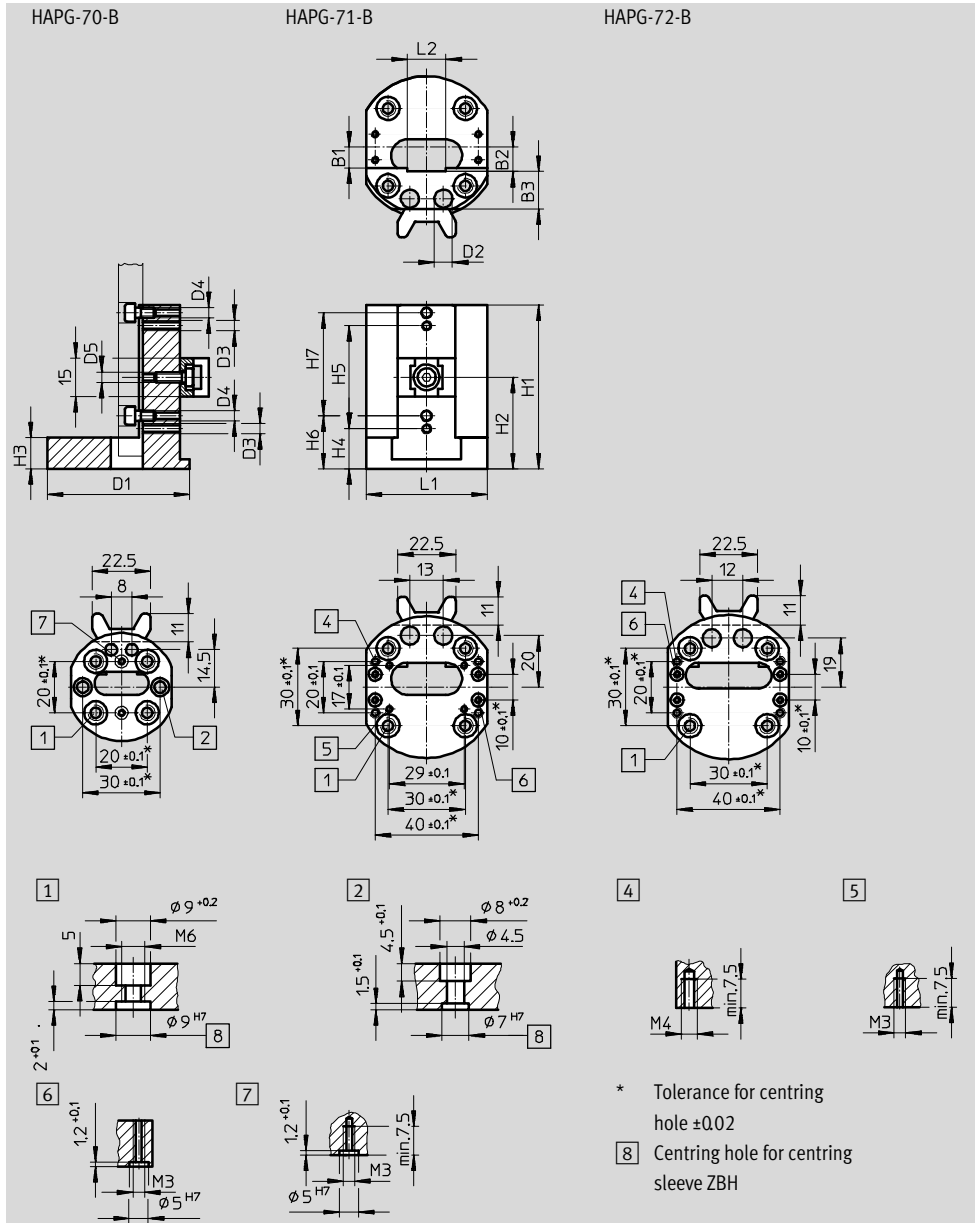

Dimensions and ordering data										
Type	B1	B2	B3	D1	D2	D3	D4	D5	H1	H2
		+0.2		∅	∅					
HAPG-70-B	5	6	11.5	42	4.5	-	M3	M4	50	28.5
HAPG-71-B	8	9.5	14.5	56	7	M4	M4	M4	63.5	35.5
HAPG-72-B	8	9.5	15	56	7	-	M4	M4	60	41.5

Type	H3	H4	H5	H6	H7	L1	L2	Weight	Part No.	Type
		+0.2	±0.2	+0.2	±0.2		+0.1	[g]		
HAPG-70-B	12	-	-	15	25	39	12	55	540881	HAPG-70-B
HAPG-71-B	12	15.5	40	20.5	40	47	15	110	540882	HAPG-71-B
HAPG-72-B	12	-	-	20.5	30	47	23.2	115	540883	HAPG-72-B

# Handling modules HSP

Accessories

FESTO

## Installation kit MKRP

Material:  
 Conduit/fitting: Polyamide  
 Reducer/lock nut:  
 Nickel-plated brass  
 Adapter plate/bracket:  
 Powder-coated steel

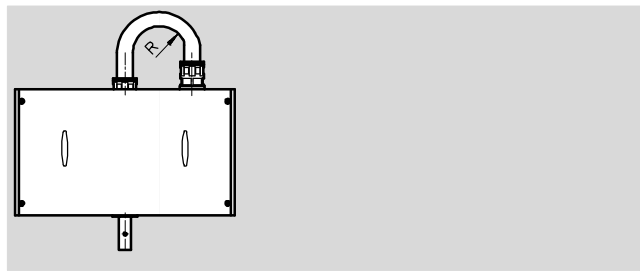

Ordering data					
For size	Max. bending radius for conduit <sup>1)</sup>	Tubing I.D.	Weight	Part No.	Type
	R	[mm]	[g]		
12	55	12	150	533632	MKRP-1
16	75	16.5	160	533633	MKRP-2
25	75	16.5	160	533634	MKRP-3

1) The conduit must not be filled beyond 70%.

## Cover kit BSD-HSP

Material:  
 Wrought aluminium alloy, anodised

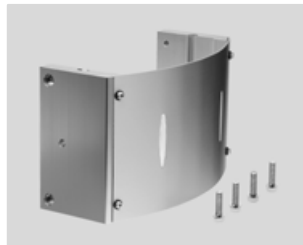

Dimensions HSP...-AP → 16  
 HSP...-AS → 20

Ordering data			
For size	Weight	Part No.	Type
	[g]		
12	825	533635	BSD-HSP-12
16	1 350	533636	BSD-HSP-16
25	1 770	533637	BSD-HSP-25

## Wait position module BWL-/BWR-HSP for HSP...-AP

Material:  
 Wrought aluminium alloy, anodised



Dimensions → 16



Ordering data				
For size	Wait position	Weight	Part No.	Type
		[g]		
12	Right	75	533623	BWR-HSP-12
	Left	75	533624	BWL-HSP-12
16	Right	135	533625	BWR-HSP-16
	Left	135	533626	BWL-HSP-16
25	Right	275	533627	BWR-HSP-25
	Left	275	533628	BWL-HSP-25



# Handling modules HSP

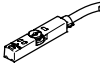
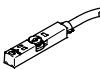

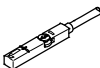
Accessories

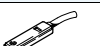
FESTO

Ordering data – Proximity sensors for T-slot, magneto-resistive						Technical data → Internet: smt	
	Type of mounting	Switch output	Electrical connection	Cable length [m]	Part No.	Type	
<b>N/O contact</b>							
	Insertable in the slot from above, flush with cylinder profile, short design	PNP	Cable, 3-wire	2.5	574335	SMT-8M-A-PS-24V-E-2,5-OE	
			Plug M8x1, 3-pin	0.3	574334	SMT-8M-A-PS-24V-E-0,3-M8D	
			Plug M12x1, 3-pin	0.3	574337	SMT-8M-A-PS-24V-E-0,3-M12	
		NPN	Cable, 3-wire	2.5	574338	SMT-8M-A-NS-24V-E-2,5-OE	
			Plug M8x1, 3-pin	0.3	574339	SMT-8M-A-NS-24V-E-0,3-M8D	
<b>N/C contact</b>							
	Insertable in the slot from above, flush with cylinder profile, short design	PNP	Cable, 3-wire	7.5	574340	SMT-8M-A-PO-24V-E-7,5-OE	

Ordering data – Proximity sensors for T-slot, magnetic reed						Technical data → Internet: sme	
	Type of mounting	Switch output	Electrical connection	Cable length [m]	Part No.	Type	
<b>N/O contact</b>							
	Insertable in the slot from above, flush with cylinder profile	Contacting	Cable, 3-wire	2.5	543862	SME-8M-DS-24V-K-2,5-OE	
				5.0	543863	SME-8M-DS-24V-K-5,0-OE	
			Cable, 2-wire	2.5	543872	SME-8M-ZS-24V-K-2,5-OE	
				Plug M8x1, 3-pin	0.3	543861	SME-8M-DS-24V-K-0,3-M8D
	Insertable in the slot lengthwise, flush with the cylinder profile	Contacting	Cable, 3-wire	2.5	150855	SME-8-K-LED-24	
			Plug M8x1, 3-pin	0.3	150857	SME-8-S-LED-24	
<b>N/C contact</b>							
	Insertable in the slot lengthwise, flush with the cylinder profile	Contacting	Cable, 3-wire	7.5	160251	SME-8-0-K-LED-24	

Ordering data – Connecting cables					Technical data → Internet: nebu	
	Electrical connection, left	Electrical connection, right	Cable length [m]	Part No.	Type	
	Straight socket, M8x1, 3-pin	Cable, open end, 3-wire	2.5	541333	NEBU-M8G3-K-2.5-LE3	
			5	541334	NEBU-M8G3-K-5-LE3	
	Straight socket, M12x1, 5-pin	Cable, open end, 3-wire	2.5	541363	NEBU-M12G5-K-2.5-LE3	
			5	541364	NEBU-M12G5-K-5-LE3	
	Angled socket, M8x1, 3-pin	Cable, open end, 3-wire	2.5	541338	NEBU-M8W3-K-2.5-LE3	
			5	541341	NEBU-M8W3-K-5-LE3	
	Angled socket, M12x1, 5-pin	Cable, open end, 3-wire	2.5	541367	NEBU-M12W5-K-2.5-LE3	
			5	541370	NEBU-M12W5-K-5-LE3	

Ordering data			Technical data → Internet: abp, hmbn	
	Brief description	Part No.	Type	
<b>Slot cover for T-slot</b>				
	For protecting against ingress of dirt and securing proximity sensor cables. Scope of delivery: 2x 0.5 m	151680	ABP-5-S	
<b>Slot nut for back plate</b>				
	Inserted from above	189654	HMBN-5-M5	

## Product Range and Company Overview

### A Complete Suite and Company Overview

Our experienced engineers provide complete support at every stage of your development process, including: conceptualization, analysis, engineering, design, assembly, documentation, validation, and production.



**Custom Automation Components**  
Complete custom engineered solutions

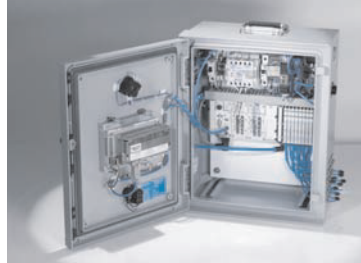

**Custom Control Cabinets**  
Comprehensive engineering support and on-site services



**Complete Systems**  
Shipment, stocking and storage services

### The Broadest Range of Automation Components

With a comprehensive line of more than 30,000 automation components, Festo is capable of solving the most complex automation requirements.



**Electromechanical**  
Electromechanical actuators, motors, controllers & drivers



**Pneumatics**  
Pneumatic linear and rotary actuators, valves, and air supply



**PLCs and I/O Devices**  
PLC's, operator interfaces, sensors and I/O devices

### Supporting Advanced Automation... As No One Else Can!

Festo is a leading global manufacturer of pneumatic and electromechanical systems, components and controls for industrial automation, with more than 16,000 employees in 60 national headquarters serving more than 180 countries. For more than 80 years, Festo has continuously elevated the state of manufacturing with innovations and optimized motion control solutions that deliver higher performing, more profitable automated manufacturing and processing equipment. Our dedication to the advancement of automation extends beyond technology to the education and development of current and future automation and robotics designers with simulation tools, teaching programs, and on-site services.

### Quality Assurance, ISO 9001 and ISO 14001 Certifications

Festo Corporation is committed to supply all Festo products and services that will meet or exceed our customers' requirements in product quality, delivery, customer service and satisfaction.

To meet this commitment, we strive to ensure a consistent, integrated, and systematic approach to management that will meet or exceed the requirements of the ISO 9001 standard for Quality Management and the ISO 14001 standard for Environmental Management.



© Copyright 2013, Festo Corporation. While every effort is made to ensure that all dimensions and specifications are correct, Festo cannot guarantee that publications are completely free of any error, in particular typing or printing errors. Accordingly, Festo cannot be held responsible for the same. For Liability and Warranty conditions, refer to our "Terms and Conditions of Sale", available from your local Festo office. All rights reserved. No part of this publication may be reproduced, distributed, or transmitted in any form or by any means, electronic, mechanical, photocopying or otherwise, without the prior written permission of Festo. All technical data subject to change according to technical update.



Printed on recycled paper at New Horizon Graphic, Inc., FSC certified as an environmental friendly printing plant.



# Festo North America

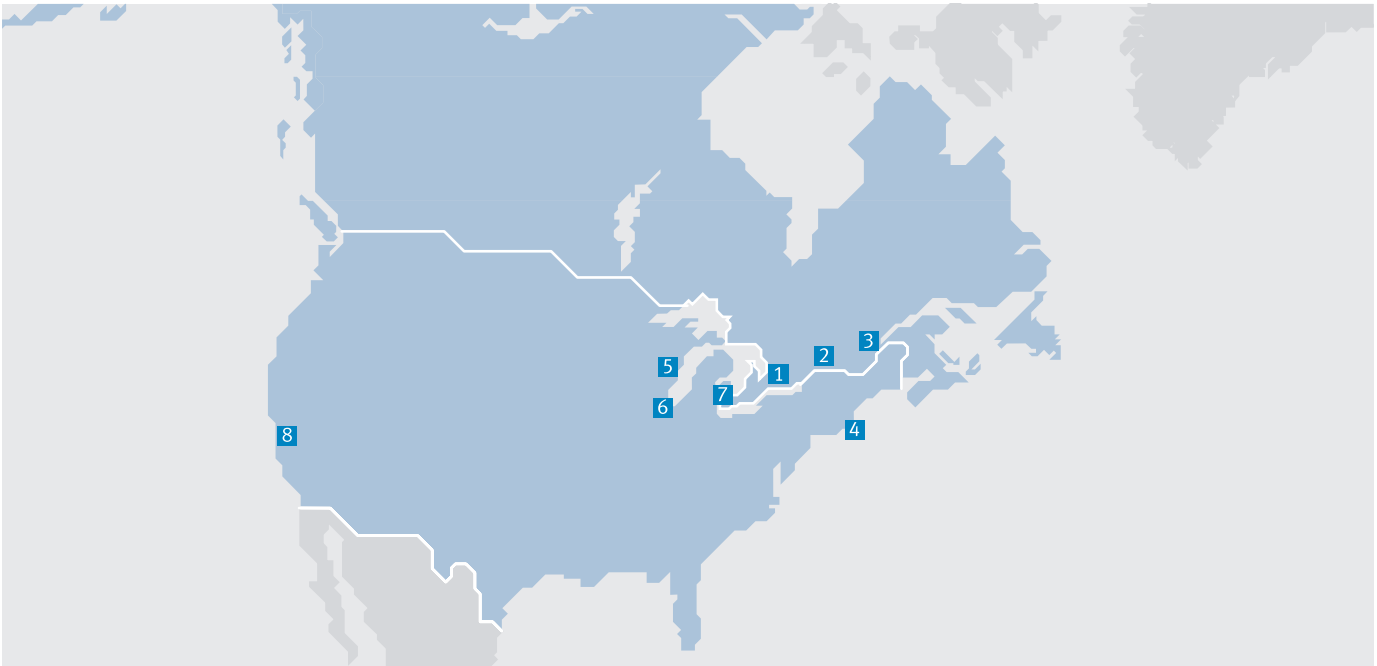

**1 Festo Canada  
Headquarters  
Festo Inc.**  
5300 Explorer Drive  
Mississauga, ON  
L4W 5G4

**2 Montréal**  
5600, Trans-Canada  
Pointe-Claire, QC  
H9R 1B6

**3 Québec City**  
2930, rue Watt#117  
Québec, QC  
G1X 4G3



**4 Festo United States  
Headquarters  
Festo Corporation**  
395 Moreland Road  
Hauppauge, NY  
11788

**5 Appleton**  
North 922 Tower View Drive, Suite N  
Greenville, WI  
54942

**7 Detroit**  
1441 West Long Lake Road  
Troy, MI  
48098

**6 Chicago**  
85 W Algonquin - Suite 340  
Arlington Heights, IL  
60005

**8 Silicon Valley**  
4935 Southfront Road, Suite F  
Livermore, CA  
94550

## Festo Regional Contact Center

### Canadian Customers

Commercial Support:  
Tel: 1 877 GO FESTO (1 877 463 3786)  
Fax: 1 877 FX FESTO (1 877 393 3786)  
Email: festo.canada@ca.festo.com

Technical Support:  
Tel: 1 866 GO FESTO (1 866 463 3786)  
Fax: 1 877 FX FESTO (1 877 393 3786)  
Email: technical.support@ca.festo.com

### USA Customers

Commercial Support:  
Tel: 1 800 99 FESTO (1 800 993 3786)  
Fax: 1 800 96 FESTO (1 800 963 3786)  
Email: customer.service@us.festo.com

Technical Support:  
Tel: 1 866 GO FESTO (1 866 463 3786)  
Fax: 1 800 96 FESTO (1 800 963 3786)  
Email: product.support@us.festo.com