

Parallel grippers HGPC



# Parallel grippers HGPC

Key features

## At a glance

### General

The compact and low-cost parallel gripper consists of a two-part symmetrical housing. The piston moves traverse to the half-shell casing in an optimum housing design that

guarantees reliable operation, long service life and convenient sensing. The gripper jaws move along the half shells in backlash-free, preloaded ball bearing guides.

- Double-acting gripper
- Compression spring for supplementary or retaining gripping forces
- Internal fixed flow control, does away with the need for external flow control in 80% of applications
- High force with minimal volume

- Suitable for external and internal gripping
- Wide range of options for attaching drive units
- Repetition accuracy of 0.05 mm
- Slot for proximity sensor
- SMT/SME-10



Note

Sizing software  
Gripper selection  
→ [www.festo.com](http://www.festo.com)

## Details

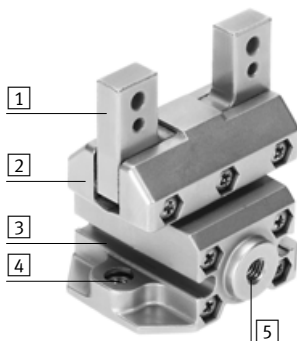

- 1 Gripper jaw with ball bearing guide
- 2 Housing based on half-shell principle
- 3 Slot for proximity sensor, for sensing the piston position
- 4 Mounting option
- 5 Supply port

## Mounting option from underneath

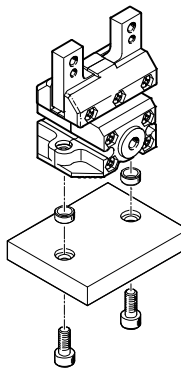

## from above

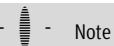
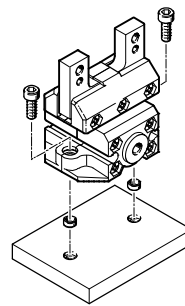

Note

Parallel grippers are not designed for the following applications:

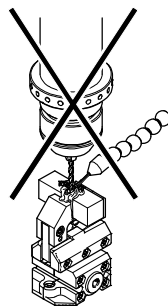

- Machining
- Aggressive media

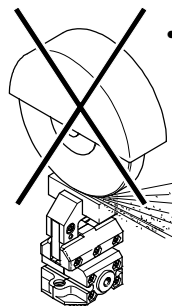

- Grinding dust

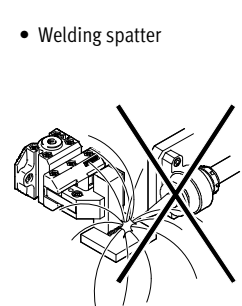

- Welding spatter

# Parallel grippers HGPC

Peripherals overview and type codes

Peripherals overview

System product for handling and assembly technology

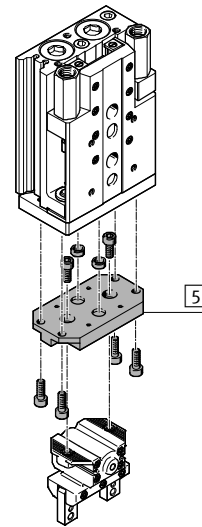
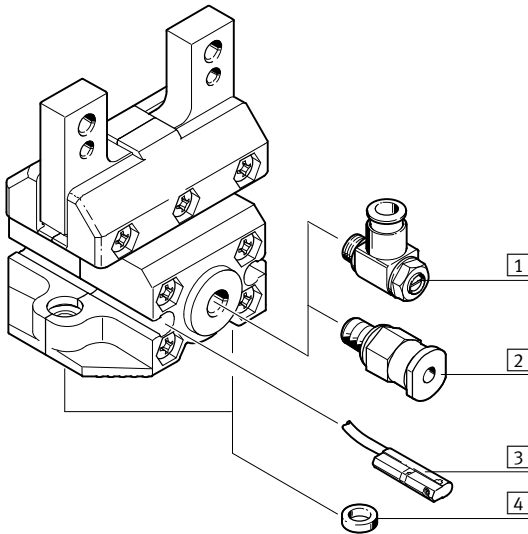

Accessories			
Type		Brief description	→ Page/Internet
1	One-way flow control valve GRLA	For regulating speed	gria
2	Push-in fitting QS	For connecting compressed air tubing with standard O.D.	quick star
3	Proximity sensor SME/SMT-10	For sensing the piston position	14
4	Centring sleeve ZBH	For centring when attaching to a drive (2 included in the scope of delivery)	14
5	Adapter kit HMSV, HAPG	Drive/gripper connections	12

Type codes

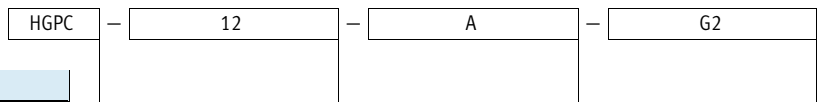

Type	
HGPC	Parallel gripper

Size	

Position sensing	
A	Via proximity sensor

Gripping force backup	
G2	Closing



# Parallel grippers HGPC

Technical data

FESTO

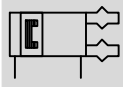
Function  
Double-acting  
HGPC-...-A



-  Size  
12, 16, 20 mm
-  Stroke  
6 ... 14 mm



Single-acting or  
with gripping force retention  
closing HGPC-...-G2



General technical data				
Size	12	16	20	
Constructional design	Wedge-shaped drive Guided motion sequence			
Mode of operation	Double-acting			
Gripper function	Parallel			
Number of gripper jaws	2			
Max. load per external gripper finger <sup>1)</sup>	[g]	20	50	80
Stroke per gripper jaw	[mm]	3	5	7
Pneumatic connection	M5			
Repetition accuracy <sup>2)</sup>	[mm]	≤ 0.05		
Max. interchangeability	[mm]	≤ 0.2		
Max. gripper jaw backlash <sup>3)</sup>	[mm]	0		
Max. gripper jaw angular backlash <sup>4)</sup>	[°]	0		
Max. operating frequency	[Hz]	4		
Rotational symmetry	[mm]	< Ø 0.2		
Position sensing	For proximity sensing			
Type of mounting	With female thread and centring sleeve			
Mounting position	Any			

- 1) Valid for unthrottled operation
- 2) End-position drift under constant conditions of use with 100 consecutive strokes in the direction of movement of the gripper jaws
- 3) Perpendicular to the direction of motion of the gripper jaws
- 4) Pretensioned, backlash-free ball bearing guide

Operating and environmental conditions			
Min. operating pressure	HGPC-...-A	[bar]	2
	HGPC-...-G2	[bar]	4
Max. operating pressure		[bar]	8
Operating medium	Compressed air in accordance with ISO 8573-1:2010 [7:4:4]		
Note on operating/pilot medium	Operation with lubricated medium possible (in which case lubricated operation will always be required)		
Ambient temperature <sup>1)</sup>		[°C]	+5 ... +60
Corrosion resistance class CRC <sup>2)</sup>			2

- 1) Note operating range of proximity sensors
- 2) Corrosion resistance class 2 according to Festo standard 940 070  
Components requiring moderate corrosion resistance. Externally visible parts with primarily decorative surface requirements which are in direct contact with a normal industrial environment or media such as coolants or lubricating agents

Weights [g]			
Size	12	16	20
HGPC-...-A	152	241	473
HGPC-...-G2	154	244	477

# Parallel grippers HGPC

Technical data

## Materials

Sectional view

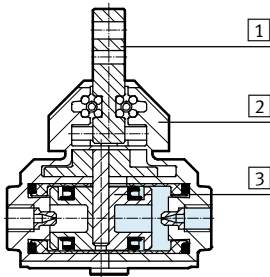

Parallel gripper		
1	Gripper jaw	High-alloy steel
2	Housing	Die-cast zinc
3	Piston	Polyamide
-	Seals	Polyurethane, nitrile rubber
-	Note on materials	Copper, PTFE and silicone-free Conforms to RoHS

## Gripping force [N] at 6 bar

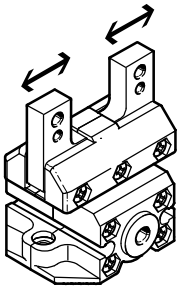

Size	12	16	20
Gripping force per gripper jaw			
Opening	22	41.5	63
Closing	22	41.5	63
Total gripping force			
Opening	44	83	126
Closing	44	83	126

## Static characteristic load values at the gripper jaws

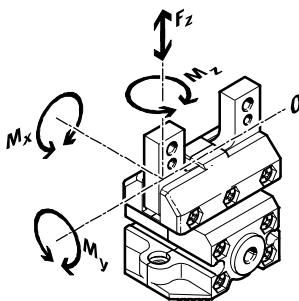

Indicated permissible forces and torques apply to a single gripper jaw. The indicated values include the lever arm, additional applied loads caused by the workpiece or external gripper fingers, as well as forces which occur

during movement. The zero coordinate line (gripper finger guide) must be taken into consideration for the calculation of torques.

Size	12	16	20	
Max. permissible force $F_z$	[N]	40	80	120
Max. permissible torque $M_x$	[Nm]	1	2,5	5
Max. permissible torque $M_y$	[Nm]	1	2,5	5
Max. permissible torque $M_z$	[Nm]	1	2,5	5

# Parallel grippers HGPC

Technical data

## Mass moment of inertia [kgm<sup>2</sup>x10<sup>-4</sup>]

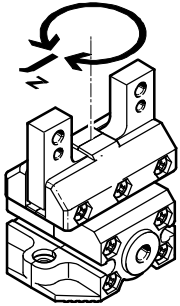

Mass moment of inertia [kgm<sup>2</sup>x10<sup>-4</sup>] of the parallel gripper in relation to the central axis with no load.

Size	12	16	20
HGPC-...-A	0.272	0.679	2.095
HGPC-...-G2	0.274	0.683	2.105

## Opening and closing times [ms] at 6 bar

without external gripper fingers

with external gripper fingers

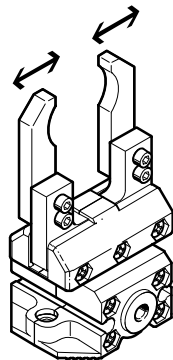
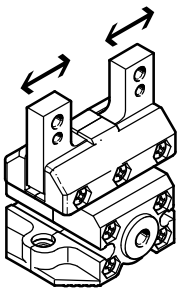

The indicated opening and closing times [ms] have been measured at room temperature and at 6 bar operating pressure with horizontally mounted gripper without additional

gripper fingers. The grippers must be throttled for greater loads [g]. Opening and closing times must then be adjusted correspondingly.

Size		12	16	20
without external gripper fingers				
HGPC-...-A	Opening	30	60	90
	Closing	30	60	90
HGPC-...-G2	Opening	30	70	105
	Closing	30	50	75
with external gripper fingers as a function of the load				
HGPC-...	40 g	40	-	-
	50 g	60	-	-
	60 g	80	-	-
	70 g	-	80	-
	100 g	-	100	-
	120 g	-	-	100

# Parallel grippers HGPC

Technical data

## Gripping force $F_{Grip}$ per gripper jaw as a function of operating pressure and lever arm $x$

Gripping forces as a function of the operating pressure and the lever arm can be determined for the size using the following graph.

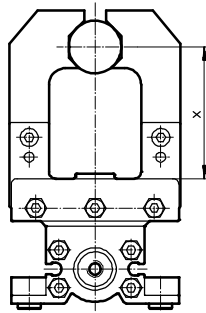

HGPC-12-A

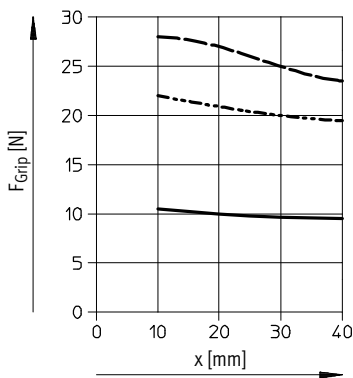

HGPC-16-A

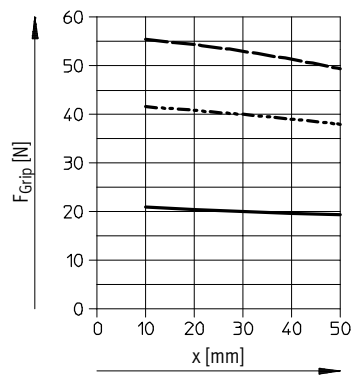

HGPC-20-A

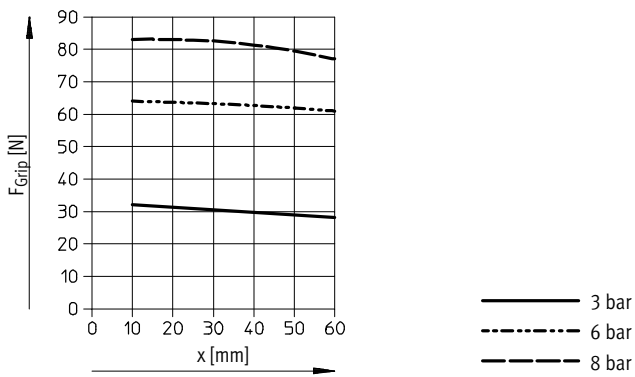

# Parallel grippers HGPC

Technical data

## Spring force $F_S$ as a function of the gripper size and the overall stroke $l$

Gripping force retention for HGPC-...-G2

Spring forces  $F_S$  as a function of the gripper size and the overall stroke  $l$  for various gripper types (HGPC-...-G2) can be determined using the following graphs.

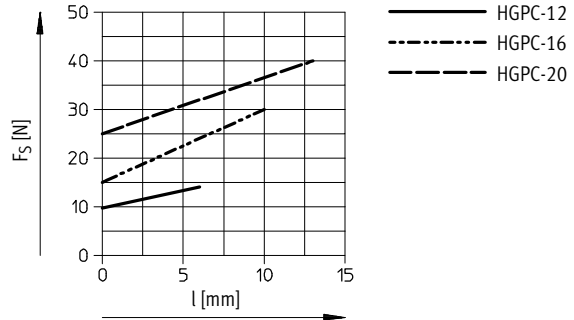
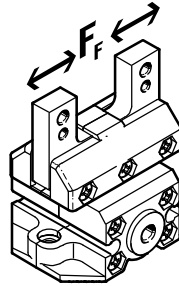

The lever arm  $x$  must be taken into consideration when determining the actual spring force  $F_{Stotal}$ . The formulae for calculating the spring force are provided in the table opposite.

Size	$F_{Stotal} =$
12	$-0.02 * x + 0.5 * F_S$
16	$-0.05 * x + 0.5 * F_S$
20	$-0.05 * x + 0.5 * F_S$

## Determination of the actual gripping forces $F_{Gr}$ for HGPC-...-G2 depending on the application

Parallel grippers with integrated spring type HGPC-...-G2 (closing gripping force retention) can be used as:  
 – single-acting grippers

- grippers with supplementary gripping force
- grippers with gripping force retention

In order to calculate available gripping forces  $F_{Gr}$  (per gripper jaw), the gripping force ( $F_{Grip}$ ) and spring

force ( $F_{Stotal}$ ) must be combined accordingly.

### Application

Single-acting

Supplementary gripping force

Gripping force retention

- Gripping with spring force:  
 $F_{Gr} = F_{Stotal}$
- Gripping with pressure force:  
 $F_{Gr} = F_{Grip} - F_{Stotal}$

- Gripping with pressure and spring force:  
 $F_{Gr} = F_{Grip} + F_{Stotal}$

- Gripping with spring force:  
 $F_{Gr} = F_{Stotal}$



# Parallel grippers HGPC

Technical data

## Gripping force $F_{Grip}$ per gripper jaw at 6 bar as a function of lever arm $x$ and eccentricity $y$

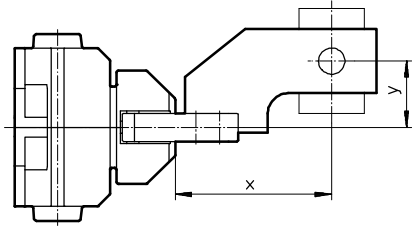

Gripping forces at 6 bar dependent upon eccentric application of force and the maximum permissible off-centre point of force application can be determined for the size using the following graph.

### Calculation example

Given:

Lever arm  $x = 20$  mm

Eccentricity  $y = 22$  mm

To be found:

Gripping force at 6 bar

Procedure:

- Determine the intersection  $xy$  between lever arm  $x$  and eccentricity  $y$  in the graph for HGPC-12-A-...
- Draw an arc (with centre at origin) through intersection  $xy$ .
- Determine the intersection between the arc and the X axis.
- Read the gripping force.

Result:

Gripping force  $F =$  approx. 20.5 N

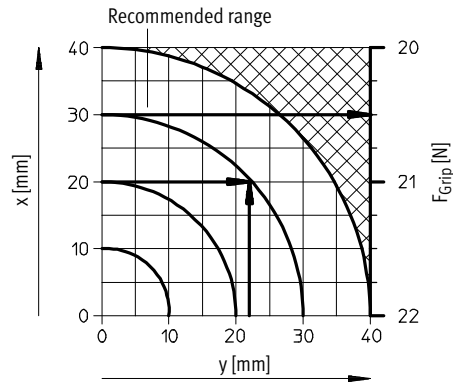

### HGPC-12-A

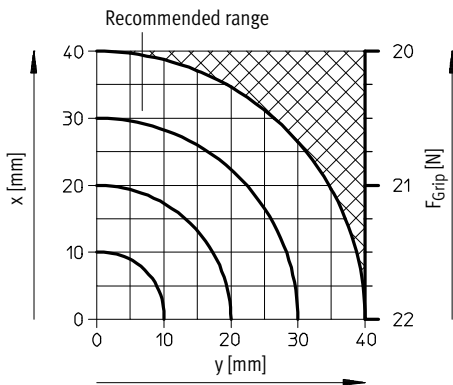

### HGPC-16-A

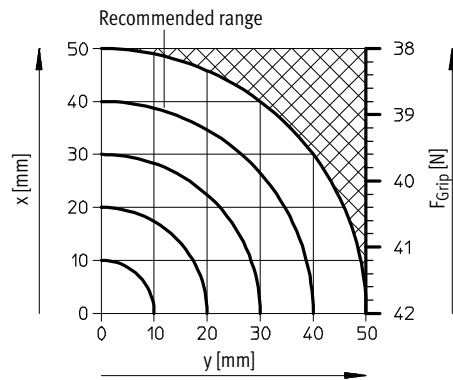

### HGPC-20-A

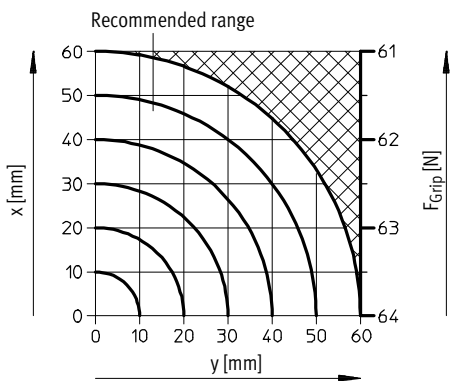

# Parallel grippers HGPC

Technical data

FESTO

## Dimensions

Download CAD data → [www.festo.com](http://www.festo.com)

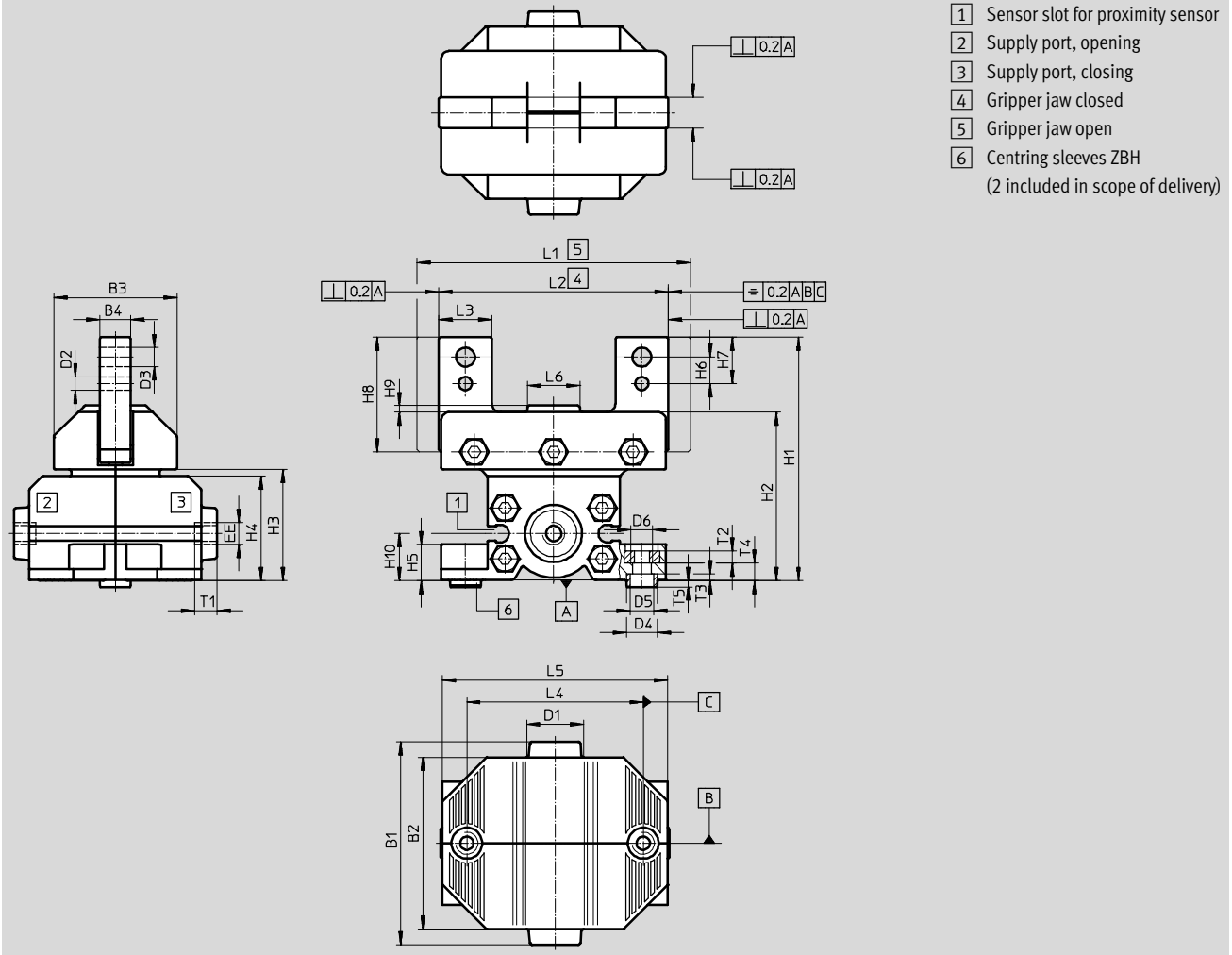

Size	B1	B2	B3	B4	D1	D2	D3	D4	D5	D6
[mm]				±0.1			±0.1	∅ F10/h7	∅	
12	38	33	22.4	6	12	2.5 <sup>+0.04/+0.01</sup>	3.3	7	5.3	M4
16	46	39	28	7	12	3 <sup>H8</sup>	4.3	7	5.3	M5
20	57	50	35	8	12	4 <sup>H8</sup>	5.3	9	6.4	M6

Size	EE	H1	H2	H3	H4	H5	H6	H7	H8	H9	H10
[mm]		±0.5							-0.2		
12	M5	48.2	33.6	21.7	20.2	6.9	5 <sup>+0.05/-0.1</sup>	9 <sup>+0.05/-0.1</sup>	25	1.2	9.2
16	M5	55.2	38.2	25.2	23.7	8.2	6±0.1	10.5±0.4	28.5	1.5	10.7
20	M5	68.7	48.2	32.5	30.5	10.2	7.5±0.1	13±0.4	34.5	1.5	13.7

Size	L1	L2	L3	L4 <sup>1)</sup>	L5	L6	T1	T2	T3	T4	T5
[mm]	±0.5	±0.5					min.		±0.1	+0.4 -0.3	+0.1 -0.3
12	45	39	10 <sup>-0.02/-0.06</sup>	33	42	10	4.5	2.2	1.7	3.1	1.3
16	62	52	12 <sup>-0.05</sup>	40	51	12	4.5	2.7	1.8	3.8	1.2
20	77	63	14 <sup>-0.05</sup>	50	65	16	4.5	3.2	2.3	5.2	1.7

1) Tolerance for centring hole ±0.03  
Tolerance for thread ±0.1

# Parallel grippers HGPC

Technical data

FESTO

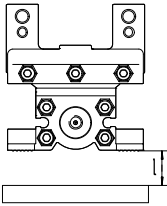

Minimum distance l between gripper and ferritic object			
		12	16
Distance	[mm]	10	

Ordering data					
	Size [mm]	Double-acting Without compression spring		Single-acting or with gripping force retention Closing	
		Part No.	Type	Part No.	Type
	12	539 267	HGPC-12-A	539 268	HGPC-12-A-G2
	16	539 269	HGPC-16-A	539 270	HGPC-16-A-G2
	20	539 271	HGPC-20-A	539 272	HGPC-20-A-G2

# Parallel grippers HGPC

Accessories

FESTO

Adapter kit  
HAPG

Material:  
Wrought aluminium alloy  
Free of copper and PTFE  
RoHS-compliant



Note

The kit includes the individual mounting interface as well as the necessary mounting material.

Permissible drive/gripper combinations with adapter kit						Download CAD data → <a href="http://www.festo.com">www.festo.com</a>	
Combination	Drive Size	Gripper Size	Mounting option		Adapter kit		
					CRC <sup>1)</sup>	Part No.	Type
<b>DGSL/HGPC</b>	DGSL	HGPC			HAPG		
	12, 16	12	■	■	2	529018	HAPG-58
	20, 25	16	■	■		191267	HAPG-49
	20, 25	20	■	■		191269	HAPG-51
<b>SLT/HGPC</b>	SLT	HGPC			HAPG		
	10	12	■	–	2	542670	HAPG-100
	16	12	■	–		529018	HAPG-58
	16	16	■	–		542666	HAPG-101
	20	16	■	–		191267	HAPG-49
	20	20	■	–		542667	HAPG-102
	25	20	■	–		191269	HAPG-51
<b>HMP/HGPC</b>	HMP	HGPC			HAPG		
	16	16	–	■	2	191263	HAPG-45
	20, 25	20	–	■		191264	HAPG-46
<b>DRQD/HGPC</b>	DRQD-...-FW	HGPC			HAPG		
	12, 16	12	■	■	2	542671	HAPG-SD2-41
	16, 20	16	■	■		542668	HAPG-SD2-42
	20	20	■	■		542669	HAPG-SD2-43
	25	20	■	■		542758	HAPG-SD2-44
<b>HSP/HGPC</b>	HSP	HGPC			HAPG		
	16	16	■	–	2	191901	HAPG-55
	25	20	■	–		540882	HAPG-71-B
						191901	HAPG-55
				540883	HAPG-72-B		

1) Corrosion resistance class 2 according to Festo standard 940 070  
Components subject to moderate corrosion stress. Externally visible parts with primarily decorative surface requirements which are in direct contact with a normal industrial environment or media such as coolants or lubricating agents.

# Parallel grippers HGPC



Accessories



**Adapter kit**  
**HAPG**

Material:  
Wrought aluminium alloy  
Free of copper and PTFE  
RoHS-compliant

 Note  
The kit includes the individual mounting interface as well as the necessary mounting material.

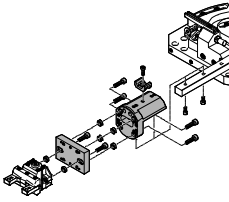
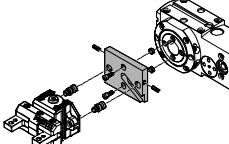
Permissible drive/gripper combinations with adapter kit						Download CAD data → <a href="http://www.festo.com">www.festo.com</a>	
Combination	Drive Size	Gripper Size	Mounting option		Adapter kit CRC <sup>1)</sup>	Part No.	Type
							
<b>HSW/HGPC</b>	<b>HSW</b>	<b>HGPC</b>			<b>HAPG</b>		
	12, 16	16	■	–	2	<b>191901</b> <b>540882</b>	<b>HAPG-55</b> <b>HAPG-71-B</b>
<b>ERMB/HGPC</b>	<b>ERMB</b>	<b>HGPC</b>			<b>HAPG</b>		
	20	16	■	■	2	<b>542668</b>	<b>HAPG-SD2-42</b>
	20	20	■	■		<b>542669</b>	<b>HAPG-SD2-43</b>
	25	20	■	■		<b>542758</b>	<b>HAPG-SD2-44</b>

1) Corrosion resistance class 2 according to Festo standard 940 070  
Components subject to moderate corrosion stress. Externally visible parts with primarily decorative surface requirements which are in direct contact with a normal industrial environment or media such as coolants or lubricating agents.

# Parallel grippers HGPC

Accessories



FESTO

Ordering data – Centring sleeves			Technical data → Internet: zbh		
	For size [mm]	Weight [g]	Part No.	Type	PU <sup>1)</sup>
	12, 16	1	<b>186717</b>	<b>ZBH-7</b>	10
	20	1	<b>150927</b>	<b>ZBH-9</b>	10

1) Packaging unit

Ordering data – Proximity sensors for C-slot					
	Type of mounting	Electrical connection, connection direction	Switching output	Cable length [m]	Part No. Type
	N/O contact, magneto-resistive <span style="float: right;">Technical data → Internet: smt</span>				
	Insertable in the slot from above	Cable, 3-wire, in-line	PNP	2.5	<b>551373 SMT-10M-PS-24V-E-2,5-L-OE</b>
		Plug M8x1, 3-pin, in-line		0.3	<b>551375 SMT-10M-PS-24V-E-0,3-L-M8D</b>
	N/O contact, magnetic reed <span style="float: right;">Technical data → Internet: sme</span>				
Insertable in the slot lengthwise	Cable, 3-wire, in-line	Contacting	2.5	<b>173210 SME-10-KL-LED-24</b>	
	Plug M8x1, 3-pin, in-line		0.3	<b>173212 SME-10-SL-LED-24</b>	

Ordering data – Proximity sensors for C-slot					
	Type of mounting	Electrical connection, connection direction	Switching output	Cable length [m]	Part No. Type
	N/O contact, magneto-resistive <span style="float: right;">Technical data → Internet: smt</span>				
	Insertable in the slot from above	Cable, 3-wire, lateral	PNP	2.5	<b>551374 SMT-10M-PS-24V-E-2,5-Q-OE</b>
		Plug M8x1, 3-pin, lateral		0.3	<b>551376 SMT-10M-PS-24V-E-0,3-Q-M8D</b>
	N/O contact, magnetic reed <span style="float: right;">Technical data → Internet: sme</span>				
Insertable in the slot lengthwise	Cable, 3-wire, lateral	Contacting	2.5	<b>173211 SME-10-KQ-LED-24</b>	
	Plug M8x1, 3-pin, lateral		0.3	<b>173213 SME-10-SQ-LED-24</b>	

Ordering data – Connecting cables				Technical data → Internet: nebu	
	Electrical connection, left	Electrical connection, right	Cable length [m]	Part No.	Type
	Straight socket, M8x1, 3-pin	Cable, open end, 3-wire	2.5	<b>541333</b>	<b>NEBU-M8G3-K-2.5-LE3</b>
			5	<b>541334</b>	<b>NEBU-M8G3-K-5-LE3</b>
	Angled socket, M8x1, 3-pin	Cable, open end, 3-wire	2.5	<b>541338</b>	<b>NEBU-M8W3-K-2.5-LE3</b>
			5	<b>541341</b>	<b>NEBU-M8W3-K-5-LE3</b>

## Product Range and Company Overview

### A Complete Suite and Company Overview

Our experienced engineers provide complete support at every stage of your development process, including: conceptualization, analysis, engineering, design, assembly, documentation, validation, and production.



**Custom Automation Components**  
Complete custom engineered solutions



**Custom Control Cabinets**  
Comprehensive engineering support and on-site services



**Complete Systems**  
Shipment, stocking and storage services

### The Broadest Range of Automation Components

With a comprehensive line of more than 30,000 automation components, Festo is capable of solving the most complex automation requirements.



**Electromechanical**  
Electromechanical actuators, motors, controllers & drivers



**Pneumatics**  
Pneumatic linear and rotary actuators, valves, and air supply



**PLCs and I/O Devices**  
PLC's, operator interfaces, sensors and I/O devices

### Supporting Advanced Automation... As No One Else Can!

Festo is a leading global manufacturer of pneumatic and electromechanical systems, components and controls for industrial automation, with more than 16,000 employees in 60 national headquarters serving more than 180 countries. For more than 80 years, Festo has continuously elevated the state of manufacturing with innovations and optimized motion control solutions that deliver higher performing, more profitable automated manufacturing and processing equipment. Our dedication to the advancement of automation extends beyond technology to the education and development of current and future automation and robotics designers with simulation tools, teaching programs, and on-site services.

### Quality Assurance, ISO 9001 and ISO 14001 Certifications

Festo Corporation is committed to supply all Festo products and services that will meet or exceed our customers' requirements in product quality, delivery, customer service and satisfaction.

To meet this commitment, we strive to ensure a consistent, integrated, and systematic approach to management that will meet or exceed the requirements of the ISO 9001 standard for Quality Management and the ISO 14001 standard for Environmental Management.

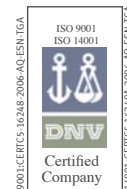

© Copyright 2013, Festo Corporation. While every effort is made to ensure that all dimensions and specifications are correct, Festo cannot guarantee that publications are completely free of any error, in particular typing or printing errors. Accordingly, Festo cannot be held responsible for the same. For Liability and Warranty conditions, refer to our "Terms and Conditions of Sale", available from your local Festo office. All rights reserved. No part of this publication may be reproduced, distributed, or transmitted in any form or by any means, electronic, mechanical, photocopying or otherwise, without the prior written permission of Festo. All technical data subject to change according to technical update.



Printed on recycled paper at New Horizon Graphic, Inc., FSC certified as an environmental friendly printing plant.

# Festo North America

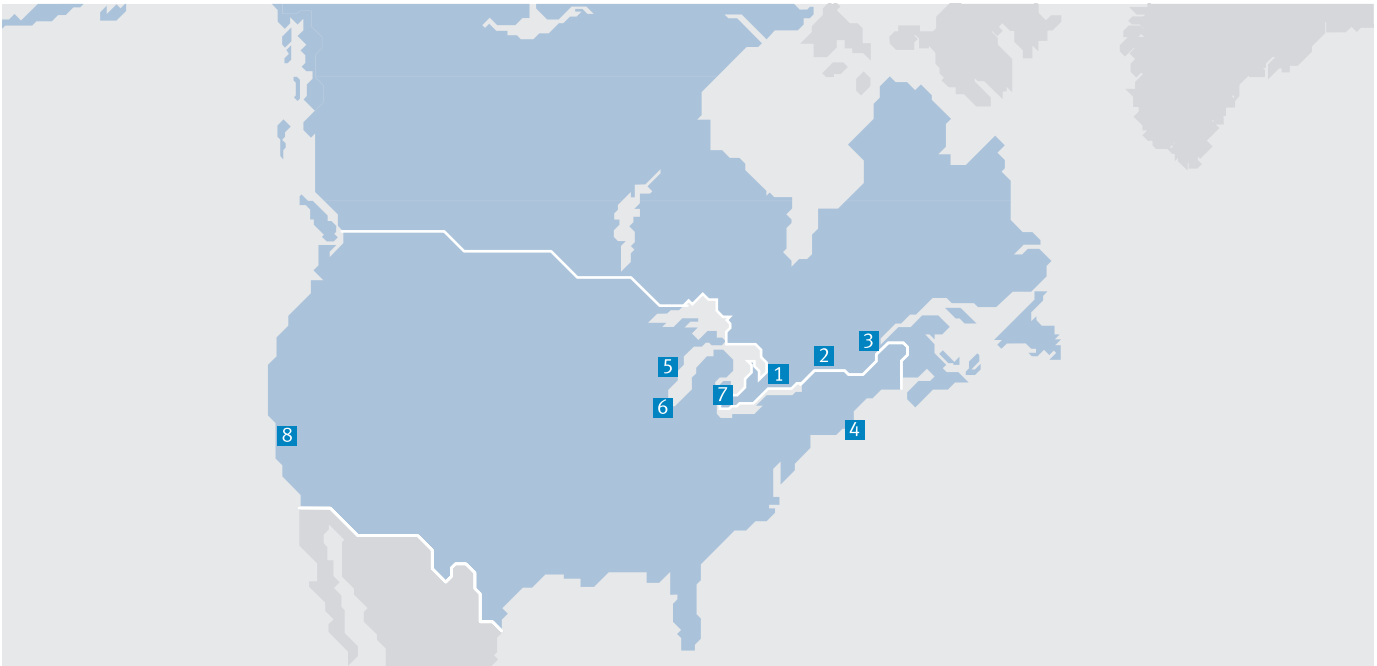

**1 Festo Canada  
Headquarters  
Festo Inc.**  
5300 Explorer Drive  
Mississauga, ON  
L4W 5G4

**2 Montréal**  
5600, Trans-Canada  
Pointe-Claire, QC  
H9R 1B6

**3 Québec City**  
2930, rue Watt#117  
Québec, QC  
G1X 4G3



**4 Festo United States  
Headquarters  
Festo Corporation**  
395 Moreland Road  
Hauppauge, NY  
11788

**5 Appleton**  
North 922 Tower View Drive, Suite N  
Greenville, WI  
54942

**7 Detroit**  
1441 West Long Lake Road  
Troy, MI  
48098

**6 Chicago**  
85 W Algonquin - Suite 340  
Arlington Heights, IL  
60005

**8 Silicon Valley**  
4935 Southfront Road, Suite F  
Livermore, CA  
94550

## Festo Regional Contact Center

### Canadian Customers

Commercial Support:  
Tel: 1 877 GO FESTO (1 877 463 3786)  
Fax: 1 877 FX FESTO (1 877 393 3786)  
Email: festo.canada@ca.festo.com

Technical Support:  
Tel: 1 866 GO FESTO (1 866 463 3786)  
Fax: 1 877 FX FESTO (1 877 393 3786)  
Email: technical.support@ca.festo.com

### USA Customers

Commercial Support:  
Tel: 1 800 99 FESTO (1 800 993 3786)  
Fax: 1 800 96 FESTO (1 800 963 3786)  
Email: customer.service@us.festo.com

Technical Support:  
Tel: 1 866 GO FESTO (1 866 463 3786)  
Fax: 1 800 96 FESTO (1 800 963 3786)  
Email: product.support@us.festo.com