

Swivel/gripper units HGDS-B



Swivel/gripper units HGDS-B

Key features



At a glance

- Combination of parallel gripper with T-slot guide and swivel module on the basis of swivel module DSM
- Infinitely adjustable swivel angle (max. 210°)
- Supply ports and position sensing outside the swivel range
- High performance (torque, mass moment of inertia)
- All connections accessible from one side
- Compact design and low weight

The technology in detail

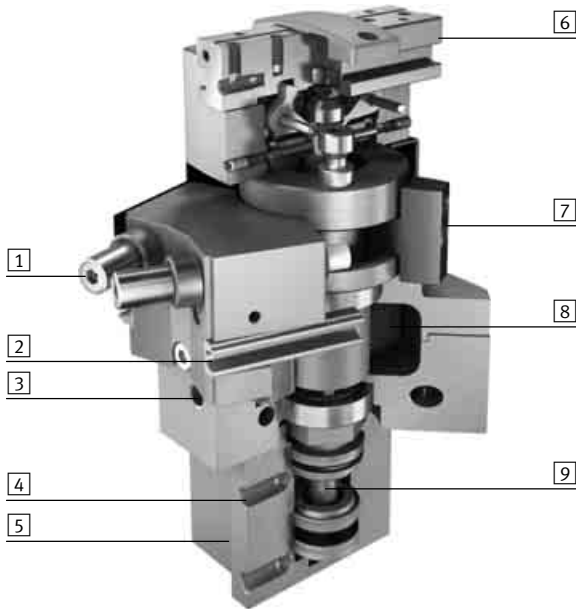

- 1 Three types of cushioning for swivel motion:
 - Flexible cushioning elements (P)
 - Adjustable flexible cushioning components with metal fixed stop (P1)
 - Shock absorbers with metal fixed stop (YSRT)
- 2 Slot for proximity sensor SME/SMT-10 for sensing the swivel position
- 3 Supply port for swivelling function
- 4 Supply port for gripping function
- 5 Slot for proximity sensor SME/SMT-10 for sensing the gripping position
- 6 Gripper jaw with T-slot guide
- 7 Adjustable stop cams for adjusting the swivel motion
- 8 Rotary vane
- 9 Piston rod for gripping motion

Mounting options

Direct mounting

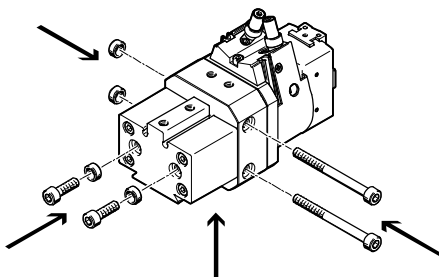

Dovetail connection

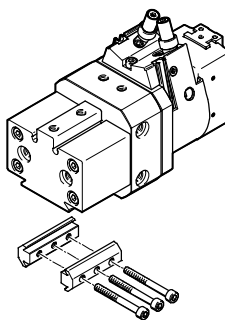

The swivel/gripper unit can be mounted on four sides.

- - Note

Swivel/gripper units are not suitable for the following or similar applications:

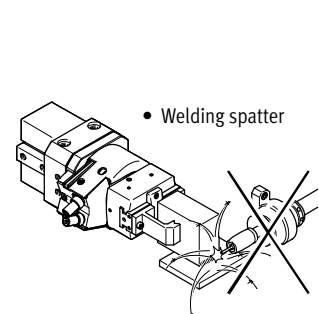
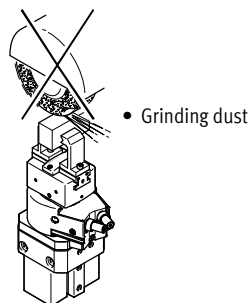
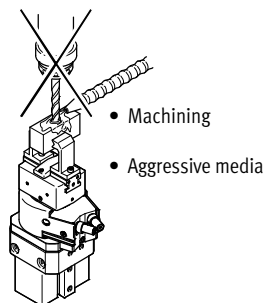

Swivel/gripper units HGDS-B

Peripherals overview and type codes

Peripherals overview

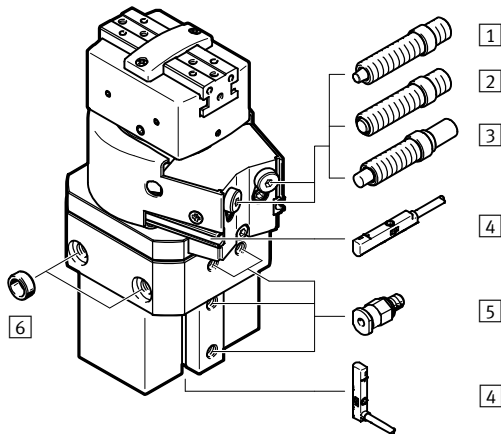

System product for handling and assembly technology

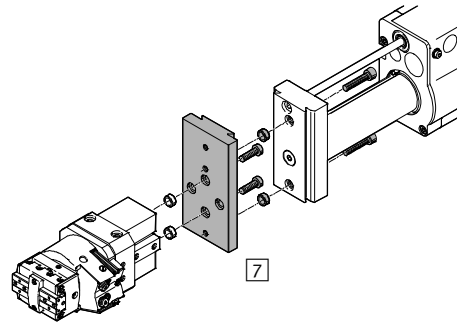

Accessories			
Type	Description	→ Page/Internet	
1 Cushioning P	Flexible cushioning components at both ends	14	
2 Cushioning P1	Adjustable flexible cushioning components at both ends, with metal fixed stop	14	
3 Cushioning YSRT	Self-adjusting shock absorbers at both ends, with metal fixed stop	14	
4 Proximity sensor SME/SMT-10	For sensing the gripping and swivelling position	16	
5 Push-in fitting QS	For connecting compressed air tubing with standard O.D.	quick star	
6 Centring sleeve ZBH	For centring the gripper when mounting (2 included in the scope of delivery)	16	
7 Adapter kit HMSV	Drive/gripper connections	15	

Type codes

HGDS – PP – 16 – YSRT – A – B

Type

HGDS Swivel/gripper unit

Gripper function

PP Parallel gripper

Size

Cushioning

P	Flexible cushioning components at both ends
P1	Adjustable flexible cushioning components at both ends
YSRT	Self-adjusting shock absorbers at both ends

Position sensing

A Via proximity sensor

Generation

B B series

Swivel/gripper units HGDS-B



Technical data

FESTO

Function
Swivelling/gripping

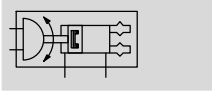
 www.festo.com



-  - Size
12, 16, 20 mm
-  - Stroke
5, 9, 14 mm

General technical data				
Size	12	16	20	
Design	Parallel gripper			
	Swivel module			
	Gripper module			
Mode of operation	Double-acting			
Pneumatic connection	M5			
Type of mounting	Via female thread and centring sleeve			
	Via through-hole and centring sleeve			
	Via dovetail slot			
Cushioning				
P cushioning	Flexible cushioning at both ends components			
P1 cushioning	Adjustable flexible cushioning components at both ends			
YSRT cushioning	Self-adjusting shock absorbers at both ends			
Mounting position	Any			
Relubrication intervals of guide	10 million switching cycles			
Product weight	[g]	505	730	1260
Technical data – swivelling	→ 5			
Technical data – gripping	→ 8			

Operating and environmental conditions		
Operating pressure	[bar]	3 ... 8
Operating medium	Compressed air in accordance with ISO 8573-1:2010 [7:4:4]	
Note on operating/pilot medium	Operation with lubricated medium possible (in which case lubricated operation will always be required)	
Ambient temperature ¹⁾	[°C]	+5 ... +60
Corrosion resistance class CRC ²⁾	2	

1) Note operating range of proximity sensors

2) Corrosion resistance class 2 according to Festo standard 940 070

Components subject to moderate corrosion stress. Externally visible parts with primarily decorative surface requirements which are in direct contact with a normal industrial environment or media such as coolants or lubricating agents.

Materials

Sectional view

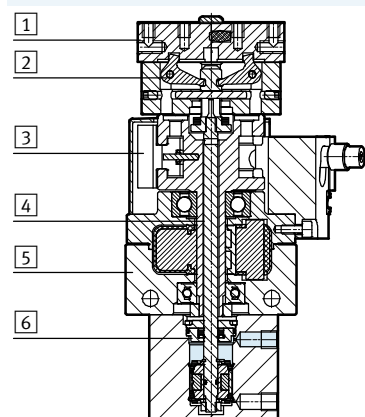

Swivel/gripper unit		
1	Gripper jaw	Stainless steel
2	Lever	Hardened steel
3	Stop	Stainless steel
4	Piston rod	Stainless steel
5	Housing	Wrought aluminium alloy
6	Piston	Nitrile rubber, polyurethane
-	Rubber buffer	Nitrile rubber

Swivel/gripper units HGDS-B

Technical data

FESTO

Technical data – Swivelling

Size		12	16	20
Swivel angle	[°]	0 ... 210		
Theoretical torque ¹⁾	[Nm]	0.85	1.25	2.5
Repetition accuracy ¹⁾				
P cushioning	[°]	< 0.2		
P1 cushioning	[°]	< 0.02		
YSRT cushioning	[°]	< 0.02		
Max. swivel frequency ¹⁾				
P cushioning	[Hz]	2		
P1 cushioning	[Hz]	2		
YSRT cushioning	[Hz]	1.5		
Position sensing		Via proximity sensor		

1) At an operating pressure of 6 bar

Mass moments of inertia J at 6 bar as a function of swivel time t and swivel angle

HGDS-PP-12-P-A-B

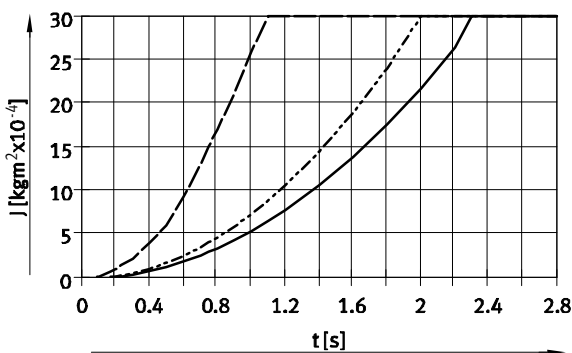

HGDS-PP-12-P1-A-B

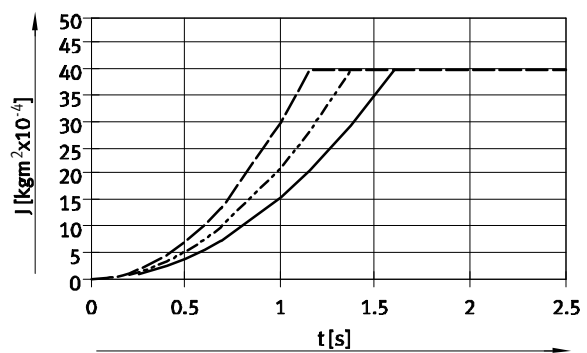

HGDS-PP-16-P-A-B

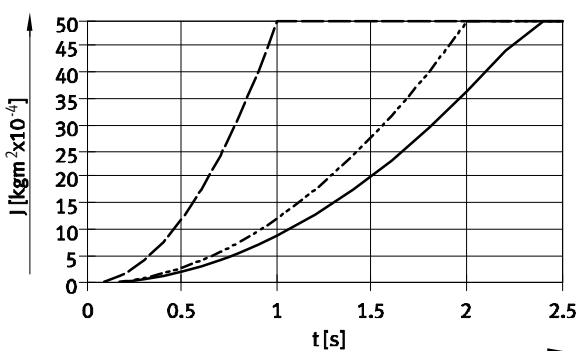

HGDS-PP-16-P1-A-B

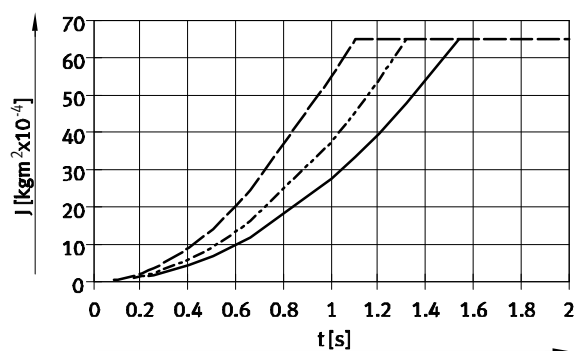

HGDS-PP-20-P-A-B

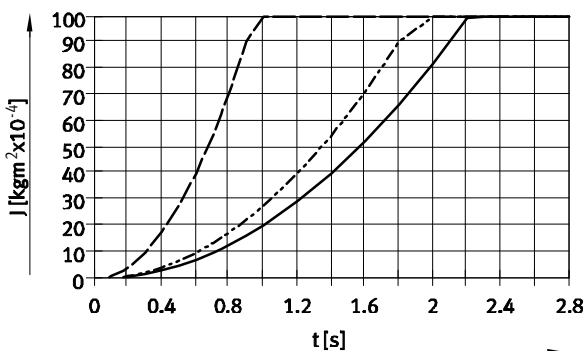

HGDS-PP-20-P1-A-B

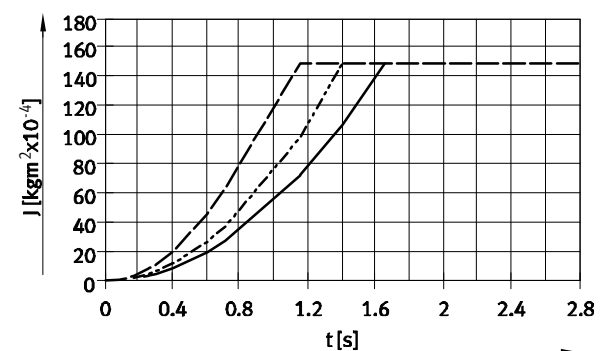

Swivel angle 210°
 Swivel angle 90°
 Swivel angle 180°

Swivel/gripper units HGDS-B

Technical data

Mass moments of inertia J at 6 bar as a function of swivel time t and swivel angle

HGDS-PP-12-YSRT-A-B

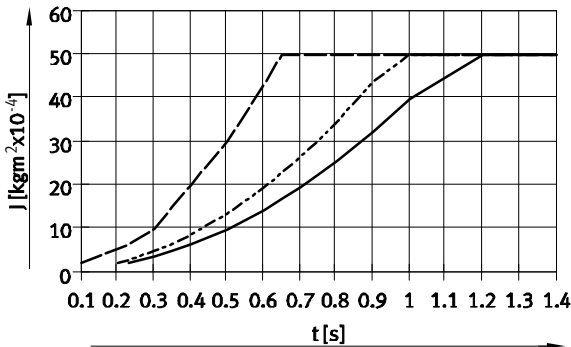

HGDS-PP-16-YSRT-A-B

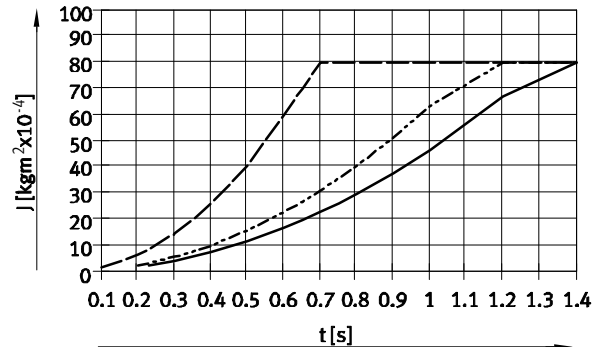

HGDS-PP-20-YSRT-A-B

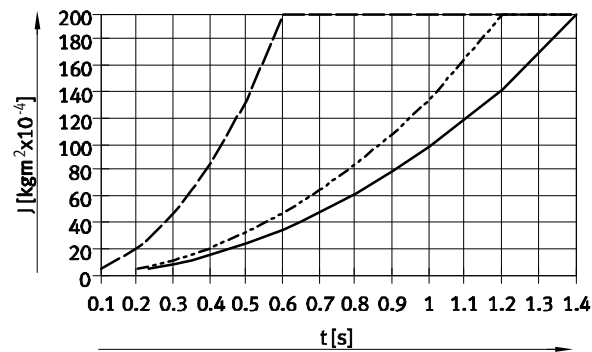

— Swivel angle 210°
 - - - Swivel angle 180°
 - · - Swivel angle 90°

Dependency between operating pressure and swivel time

Reducing the operating pressure reduces the gripping force. To ensure that the gripper's jaws do not open during swivelling, the swivel time must be increased by 15% per bar of operating pressure (same mass moment of inertia).

Swivel time at 6 bar = 0.5 s, see graph opposite

Swivel time at 4 bar:
 $t = 0.5 + 2 \times 15\% = 0.65$ s
 Cushioning time of the shock absorber = 0.1 s

Example:

Given:

HGDS-PP-16-YSRT-A-B
 Operating pressure 6 bar
 Swivel angle 90°
 $J = 40 \text{ kgm}^2 \times 10^{-4}$

This yields a total swivel time of
 $t_{\text{tot.}} = 0.65 \text{ s} + 0.1 \text{ s} = 0.75 \text{ s}$

To be calculated:

Swivel time at an operating pressure of 4 bar

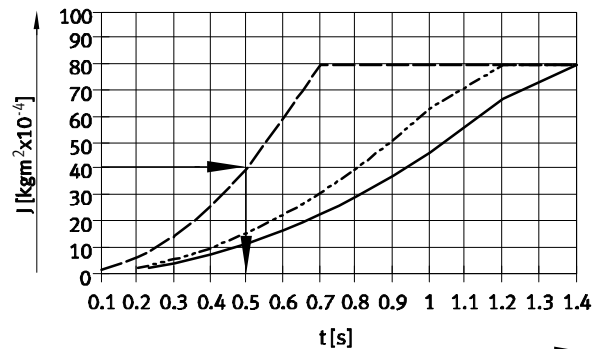

Swivel/gripper units HGDS-B

Technical data

Precision adjustment of the swivel angle

The swivel angle can be roughly adjusted by moving the cam stops → 2.

The procedure for precision adjustment is the same for all cushioning variants (P, P1 and YSRT).

The swivel angle can be precisely adjusted by unscrewing or screwing in the cushioning component.

Swivelling to a metal stop enables high repetition accuracy.

- 1) Loosen the locking screw underneath the cushioning component.

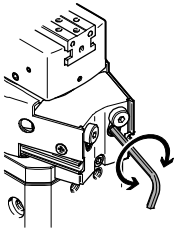

- 2) Adjust the cushioning component as required. Note the adjustment range.

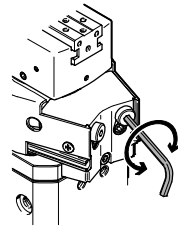

Size		12	16	20
Precision adjustment range				
P cushioning	[°]	-6		
P1 cushioning	[°]	-6		
YSRT cushioning	[°]	-2.5		
Adjustment range of the cushioning component				
P cushioning	[mm]	2	2.6	2.8
P1 cushioning	[mm]	2	2.6	2.8
YSRT cushioning	[mm]	1	1.3	1.4

Swivel/gripper units HGDS-B

Technical data



Technical data – Gripping

Size	12	16	20	
Gripper function	Parallel			
Number of gripper jaws	2			
Max. load per external gripper finger ¹⁾	[g]	30	50	100
Stroke per gripper jaw	[mm]	2.5	4.5	7
Max. gripper jaw backlash	[mm]	0.02		
Max. gripper jaw angular play	[°]	0.1		
Repetition accuracy	[mm]	±0.01		±0.015
Max. operating frequency	[Hz]	4		
Position sensing	Via proximity sensor			

1) Valid for unthrottled operation

Opening and closing times [ms] at 6 bar

Without external gripper fingers

With external gripper fingers

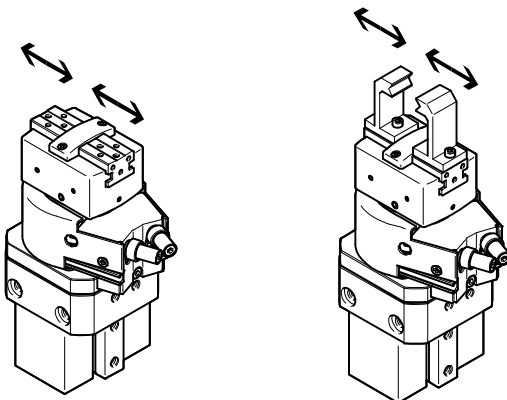

The indicated opening and closing times [ms] have been measured at room temperature and 6 bar operating pressure with vertically mounted swivel/gripper unit without additional

gripper fingers. The grippers must be throttled for greater loads [g]. Opening and closing times must then be adjusted accordingly.

With external gripper fingers as a function of the load

Size	12	16	20	
Max. load	30 g	50 g	100 g	
Unthrottled	Opening	40	40	60
	Closing	60	60	70

With external gripper fingers as a function of the load

Size	12	16	20				
Load	100 g	200 g	100 g	200 g	100 g	200 g	
Throttled	Closing	100	150	100	200	100	250

Swivel/gripper units HGDS-B

Technical data

Static characteristic load values per gripper jaw

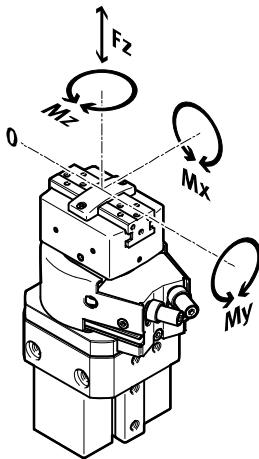

The indicated permissible forces and torques apply to a single gripper jaw. The indicated values include the lever arm, additional applied loads caused by the workpiece or external gripper fingers, as well as forces which occur during movement.

The zero coordinate line (gripper finger guide) must be taken into consideration for the calculation of torques.

Size		12	16	20
Max. permissible force F_z	[N]	90	150	250
Max. permissible torque M_x	[Nm]	6	11	22
Max. permissible torque M_y	[Nm]	6	11	22
Max. permissible torque M_z	[Nm]	6	11	22

Gripping force [N] at 6 bar with a lever arm of 25 mm

Size		12	16	20
Gripping force per gripper jaw				
Opening		42	58	96
Closing		37	51	84
Total gripping force				
Opening		84	116	192
Closing		74	102	168

Swivel/gripper units HGDS-B

Technical data

Gripping force F_H per gripper jaw as a function of operating pressure p

Gripping forces as a function of operating pressure and lever arm can be determined for the various sizes using the following graphs.

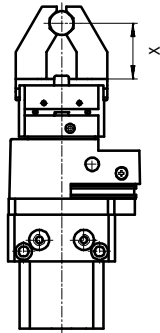

- 3 bar
- - - 6 bar
- · - 8 bar

HGDS-12

Opening

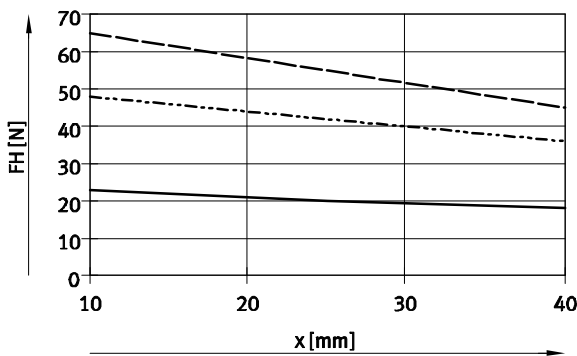

Closing

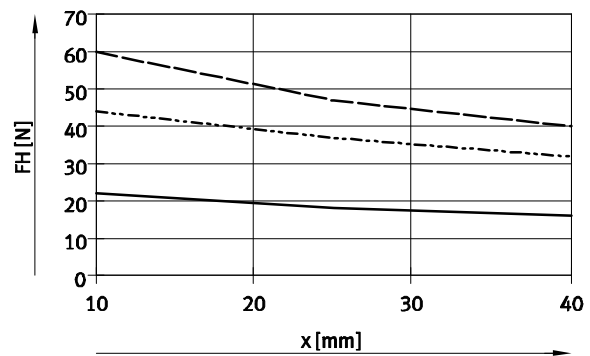

HGDS-16

Opening

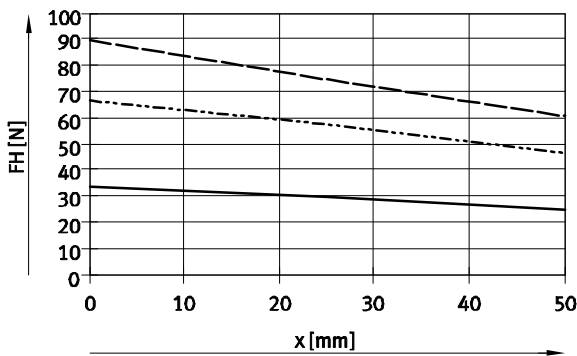

Closing

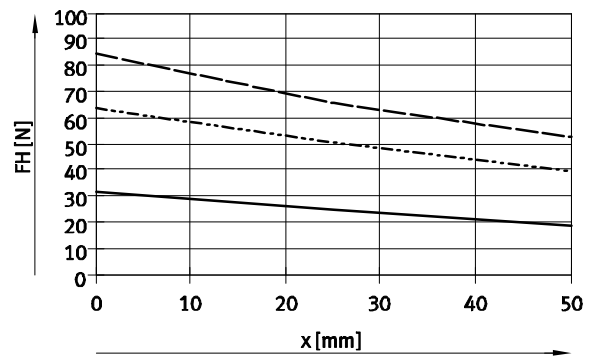

HGDS-20

Opening

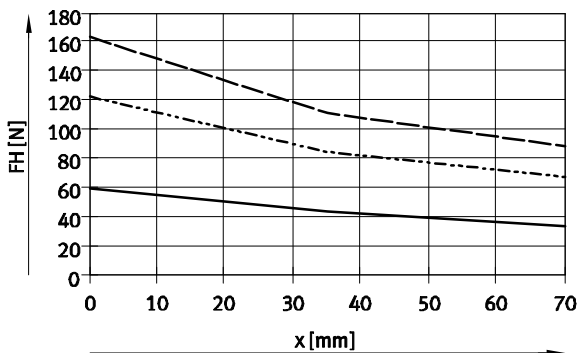

Closing

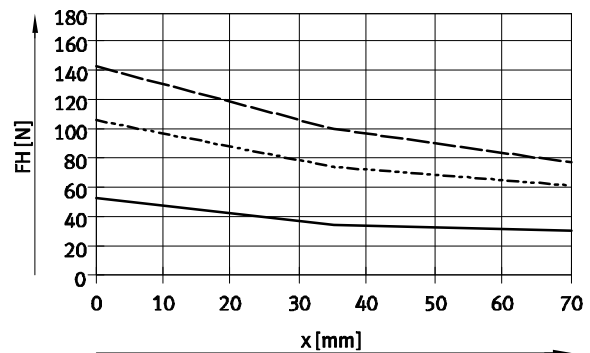

Swivel/gripper units HGDS-B

Technical data

Gripping force F_H per gripper jaw at 6 bar as a function of lever arm x and eccentricity a and b

The following formula must be used to calculate the lever arm x with eccentric gripping:

$$x = \sqrt{a^2 + b^2}$$

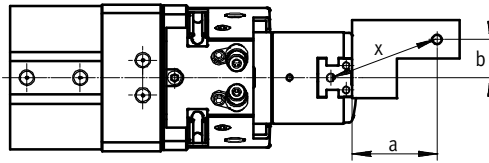

The gripping force F_H can be read from the graphs (→ from page 10) using the calculated value x .

Calculation example

Given:

Distance $a = 25$ mm

Distance $b = 20$ mm

To be calculated:

The gripping force at 6 bar, with an HGDS-16, used as an external gripper

Procedure:

Calculating the lever arm x

$$x = \sqrt{25^2 + 20^2}$$

$x = 32$ mm

The graph (→ 10) gives a value of $F_H = 47$ N for the gripping force.

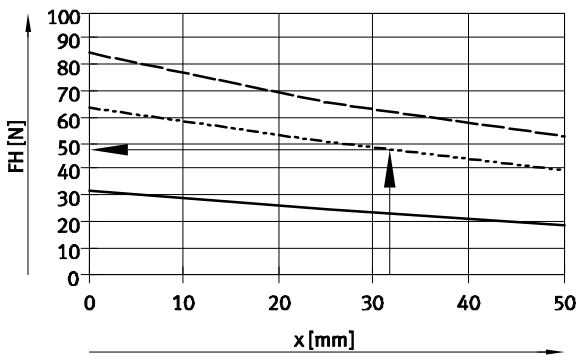

Swivel/gripper units HGDS-B

Technical data

FESTO

Dimensions

Download CAD data → www.festo.com

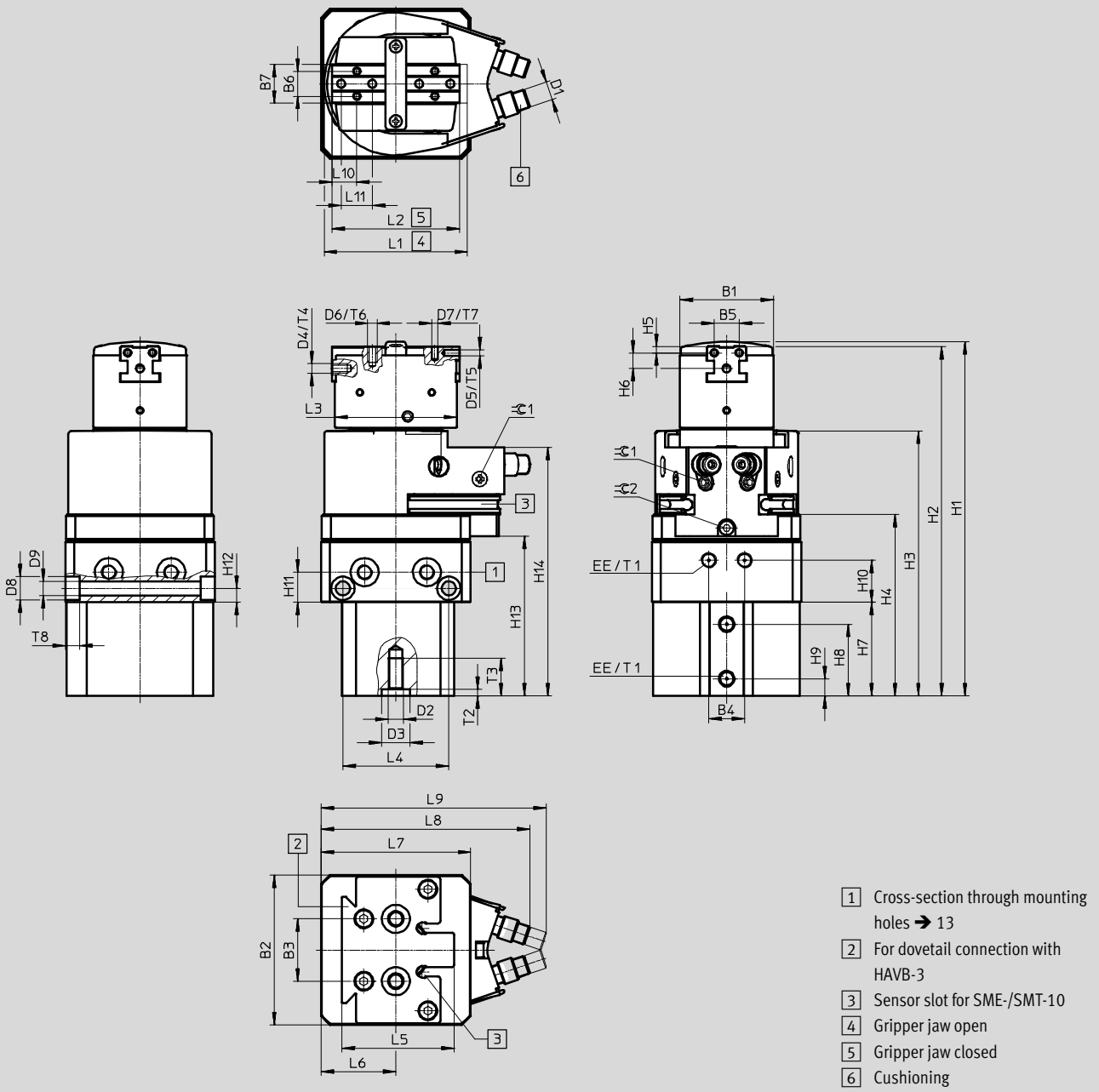

Swivel angle

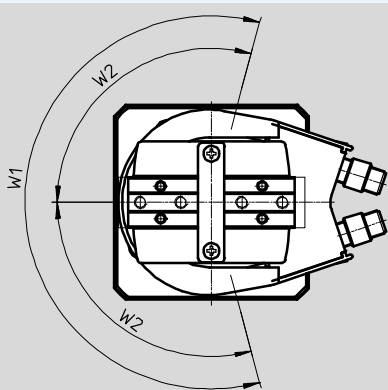

Swivel/gripper units HGDS-B

Technical data

FESTO

Cross-section at 1 → 12

Size 12

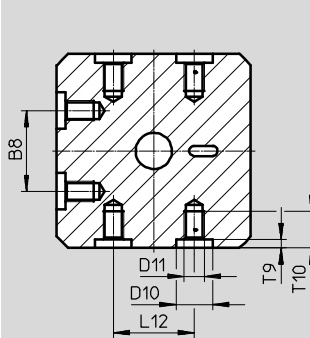

Size 16

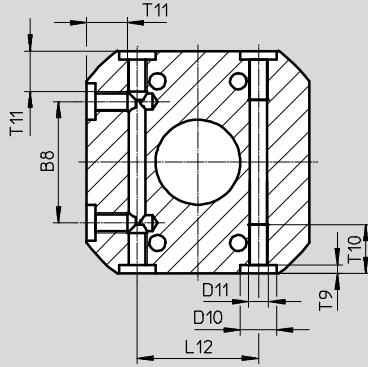

Size 20

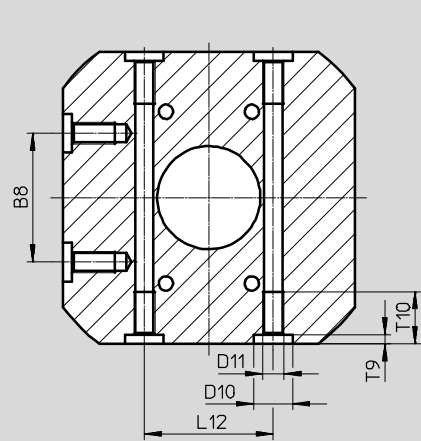

Size	B1	B2	B3	B4	B5	B6	B7	B8 ¹⁾	D1	D2	D3 ∅ H7	D4
[mm]		±0.03	±0.02		±0.02	±0.02	±0.1					
12	30	48	20	11.5	8	8	12.5	20	M6x0.5	M5	9	M3
16	34	55	30	13	10	10	16	30	M8x1	M5	9	M3
20	40	68	30	16	12	12	20	30	M10x1	M5	9	M4

Size	D5 ∅	D6	D7 ∅	D8 ∅	D9 ∅	D10 ∅	D11	EE	H1	H2	H3	H4
[mm]	H8		H8	H13	H13	H7			+1/-0.6	+0.8/-0.4	+1.3/-0.2	+0.8/-0.2
12	2	M3	2	7.5	4.5	9	M5	M5	113.4	111.9	85	58.2
16	2	M3	2	-	4.2	9	M5	M5	121.7	120.1	92.3	64.3
20	2.5	M4	2.5	-	4.2	9	M5	M5	154.8	152.8	112.3	81.7

Size	H5	H6	H7	H8	H9	H10	H11	H12	H13	H14	L1	L2
[mm]	±0.02	±0.12	±0.1	±0.1			-0.1		+1/-0.2	+1/-0.2	±0.5	±0.5
12	2	5	30	23	7.5	13.5	9.7	4.5	51.3	79.8	46	41
16	3	5	34.5	26	6.3	14	8	-	58.2	86.7	58	49
20	3	7	43	34.6	5.3	19	9	-	73.1	105.6	78	64

Size	L3	L4	L5	L6	L7	L8 ±1 P	L9 ±1		L10	L11	L12 ¹⁾	T1
							P1	YSRT				
[mm]	±0.5	±0.1		±0.05	±0.03				±0.02			min.
12	39	34	36	24	48	67	72.4	72.4	8	10	20	5.3
16	47	-	40.5	27.5	55	80.2	81.6	81.6	8	10	30	5
20	61	-	40.5	34	68	93.3	97	97	12	14	30	6

Size	T2	T3	T4	T5	T6	T7	T8	T9	T10	T11	W1	W2	∠ 1	∠ 2
[mm]	+0.1		±0.4	max.	min.	max.		+0.1						
12	2.1	12.1	6	5	3.5	6	4.6	2.1	10	-	210°	105°	2	2
16	2.1	12.1	6	6	4.5	6	-	2.1	12.1	10	210°	105°	2.5	2.5
20	2.1	12.1	9	8	6	7.5	-	2.1	12.1	-	210°	105°	3	2.5

1) Tolerance for centring holes ∅9 H7, tolerance for thread M5 ±0.1 mm

Swivel/gripper units HGDS-B

Technical data

FESTO

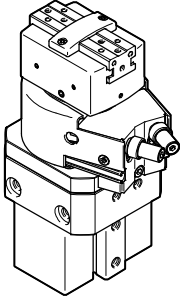
Ordering data			
	Size [mm]	Part No.	Type
	With cushioning P		
	12 ¹⁾	1187955	HGDS-PP-12-P-A-B
	16 ¹⁾	1187958	HGDS-PP-16-P-A-B
	20 ¹⁾	1187961	HGDS-PP-20-P-A-B
	With cushioning P1		
	12 ¹⁾	1187956	HGDS-PP-12-P1-A-B
	16 ¹⁾	1187959	HGDS-PP-16-P1-A-B
	20 ¹⁾	1187962	HGDS-PP-20-P1-A-B
	With cushioning YSRT		
	12 ¹⁾	1187957	HGDS-PP-12-YSRT-A-B
	16 ¹⁾	1187960	HGDS-PP-16-YSRT-A-B
	20 ¹⁾	1187963	HGDS-PP-20-YSRT-A-B

1) Two centring sleeves are included in the scope of delivery of the swivel/gripper unit.

Swivel/gripper units HGDS-B

Accessories

FESTO



Adapter kit
HMVA, HMSV, HAVB

Material:
Wrought aluminium alloy
Free of copper and PTFE
RoHS-compliant



Note

The kit includes the individual mounting interface as well as the necessary mounting material.

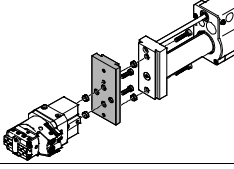
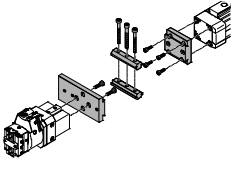
Permissible drive/gripper combinations with adapter kit						Download CAD data → www.festo.com	
Combination	Drive Size	Gripper Size	Mounting option		Adapter kit CRC ¹⁾	Part No.	Type
							
	HMP	HGDS			HAVB, HMSV		
	Direct mounting						
	16, 20, 25, 32	16, 20	-	■	2	534290	HMSV-38
	Dovetail mounting						
16, 20, 25, 32	16, 20	-	■	2	163239	HAVB-3	
						534290	HMSV-38
	DGP..., DGE-..., DGEA/HGDS	DG...	HGDS		HMSV, HMVA		
	DGP...-25	12, 16, 20	■	■	2	177653	HMSV-7
	DGE-25		■	■		534290	HMSV-38
	DGEA-18				196788	HMVA-DLA18/25	
	DGP...-40	12, 16, 20	■	■	177653	HMSV-7	
	DGE-40		■	■	534290	HMSV-38	
				196790	HMVA-DLA40		



1) Corrosion resistance class CRC 2 to Festo standard FN 940070

Moderate corrosion stress. Indoor applications in which condensation may occur. External visible parts with primarily decorative requirements for the surface and which are in direct contact with the ambient atmosphere typical for industrial applications.

Swivel/gripper units HGDS-B

Accessories



FESTO



Ordering data					
	For size	Brief description	Part No.	Type	PU ¹⁾
Cushioning kit for P/P1/YSRT cushioning					
	12	P cushioning: – Flexible cushioning component	1731537	HGDS-12-P-B	1
	16		1731540	HGDS-16-P-B	
	20		1731544	HGDS-20-P-B	
	12	P1 cushioning: – Flexible cushioning component – Adjustable – With metal fixed stop	1731536	HGDS-12-P1-B	
	16		1731539	HGDS-16-P1-B	
	20		1731542	HGDS-20-P1-B	
	12	YSRT cushioning: – Shock absorber – Self-adjusting – With metal fixed stop	1731538	HGDS-12-YSRT-B	1
	16		1731541	HGDS-16-YSRT-B	
	20		1731545	HGDS-20-YSRT-B	



1) Packaging unit

Ordering data					Technical data → Internet: zbh	
	For size	Weight [g]	Part No.	Type	PU ¹⁾	
Centring sleeve ZBH						
	12, 16, 20	1	150927	ZBH-9	10	

1) Packaging unit

Ordering data – Proximity sensors for C-slot, magneto-resistive						Technical data → Internet: smt	
	Type of mounting	Electrical connection, connection direction	Switching output	Cable length [m]	Part No.	Type	
N/O contact							
	Insertable in the slot from above	Cable, 3-wire, in-line	PNP	2.5	551373	SMT-10M-PS-24V-E-2,5-L-OE	
		Plug M8x1, 3-pin, in-line		0.3	551375	SMT-10M-PS-24V-E-0,3-L-M8D	
		Cable, 3-wire, lateral		2.5	551374	SMT-10M-PS-24V-E-2,5-Q-OE	
		Plug M8x1, 3-pin, lateral		0.3	551376	SMT-10M-PS-24V-E-0,3-Q-M8D	

Ordering data – Proximity sensors for C-slot, magnetic reed						Technical data → Internet: sme	
	Type of mounting	Electrical connection, connection direction	Switching output	Cable length [m]	Part No.	Type	
N/O contact							
	Insertable in the slot from above	Cable, 3-wire, in-line	Contacting	2.5	551365	SME-10M-DS-24V-E-2,5-L-OE	
		Cable, 2-wire, in-line		2.5	551369	SME-10M-ZS-24V-E-2,5-L-OE	
		Plug M8x1, 3-pin, in-line		0.3	551367	SME-10M-DS-24V-E-0,3-L-M8D	
		Cable, 3-wire, lateral		2.5	551366	SME-10M-DS-24V-E-2,5-Q-OE	
		Cable, 2-wire, lateral		2.5	551370	SME-10M-ZS-24V-E-2,5-Q-OE	
		Plug M8x1, 3-pin, lateral		0.3	551368	SME-10M-DS-24V-E-0,3-Q-M8D	

Ordering data – Connecting cables					Technical data → Internet: nebu	
	Electrical connection, left	Electrical connection, right	Cable length [m]	Part No.	Type	
	Straight socket, M8x1, 3-pin	Cable, open end, 3-wire	2.5	541 333	NEBU-M8G3-K-2.5-LE3	
			5	541 334	NEBU-M8G3-K-5-LE3	
	Angled socket, M8x1, 3-pin	Cable, open end, 3-wire	2.5	541 338	NEBU-M8W3-K-2.5-LE3	
			5	541 341	NEBU-M8W3-K-5-LE3	

Product Range and Company Overview

A Complete Suite and Company Overview

Our experienced engineers provide complete support at every stage of your development process, including: conceptualization, analysis, engineering, design, assembly, documentation, validation, and production.



Custom Automation Components
Complete custom engineered solutions

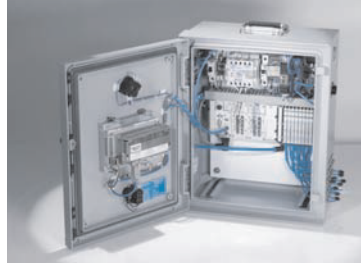

Custom Control Cabinets
Comprehensive engineering support and on-site services



Complete Systems
Shipment, stocking and storage services

The Broadest Range of Automation Components

With a comprehensive line of more than 30,000 automation components, Festo is capable of solving the most complex automation requirements.



Electromechanical
Electromechanical actuators, motors, controllers & drivers



Pneumatics
Pneumatic linear and rotary actuators, valves, and air supply



PLCs and I/O Devices
PLC's, operator interfaces, sensors and I/O devices

Supporting Advanced Automation... As No One Else Can!

Festo is a leading global manufacturer of pneumatic and electromechanical systems, components and controls for industrial automation, with more than 16,000 employees in 60 national headquarters serving more than 180 countries. For more than 80 years, Festo has continuously elevated the state of manufacturing with innovations and optimized motion control solutions that deliver higher performing, more profitable automated manufacturing and processing equipment. Our dedication to the advancement of automation extends beyond technology to the education and development of current and future automation and robotics designers with simulation tools, teaching programs, and on-site services.

Quality Assurance, ISO 9001 and ISO 14001 Certifications

Festo Corporation is committed to supply all Festo products and services that will meet or exceed our customers' requirements in product quality, delivery, customer service and satisfaction.

To meet this commitment, we strive to ensure a consistent, integrated, and systematic approach to management that will meet or exceed the requirements of the ISO 9001 standard for Quality Management and the ISO 14001 standard for Environmental Management.



© Copyright 2013, Festo Corporation. While every effort is made to ensure that all dimensions and specifications are correct, Festo cannot guarantee that publications are completely free of any error, in particular typing or printing errors. Accordingly, Festo cannot be held responsible for the same. For Liability and Warranty conditions, refer to our "Terms and Conditions of Sale", available from your local Festo office. All rights reserved. No part of this publication may be reproduced, distributed, or transmitted in any form or by any means, electronic, mechanical, photocopying or otherwise, without the prior written permission of Festo. All technical data subject to change according to technical update.



Printed on recycled paper at New Horizon Graphic, Inc., FSC certified as an environmental friendly printing plant.

Festo North America

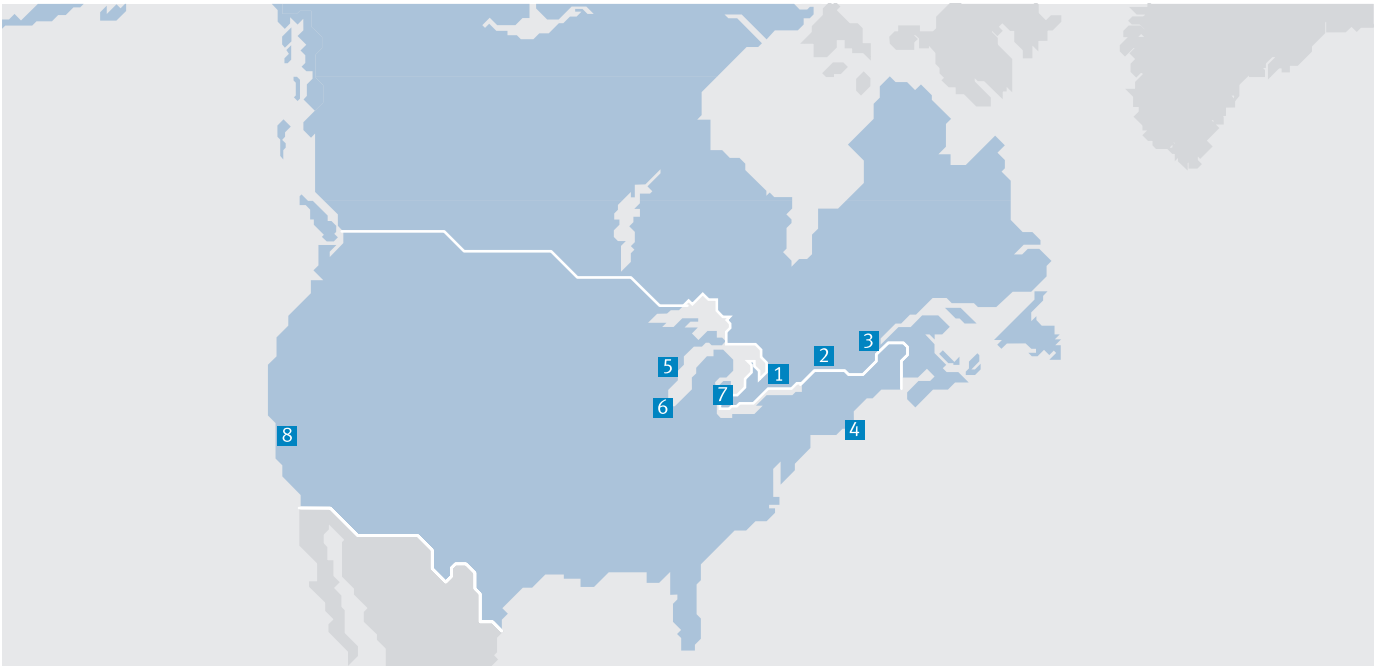

**1 Festo Canada
Headquarters
Festo Inc.**
5300 Explorer Drive
Mississauga, ON
L4W 5G4

2 Montréal
5600, Trans-Canada
Pointe-Claire, QC
H9R 1B6

3 Québec City
2930, rue Watt#117
Québec, QC
G1X 4G3



**4 Festo United States
Headquarters
Festo Corporation**
395 Moreland Road
Hauppauge, NY
11788

5 Appleton
North 922 Tower View Drive, Suite N
Greenville, WI
54942

7 Detroit
1441 West Long Lake Road
Troy, MI
48098

6 Chicago
85 W Algonquin - Suite 340
Arlington Heights, IL
60005

8 Silicon Valley
4935 Southfront Road, Suite F
Livermore, CA
94550

Festo Regional Contact Center

Canadian Customers

Commercial Support:
Tel: 1 877 GO FESTO (1 877 463 3786)
Fax: 1 877 FX FESTO (1 877 393 3786)
Email: festo.canada@ca.festo.com

Technical Support:
Tel: 1 866 GO FESTO (1 866 463 3786)
Fax: 1 877 FX FESTO (1 877 393 3786)
Email: technical.support@ca.festo.com

USA Customers

Commercial Support:
Tel: 1 800 99 FESTO (1 800 993 3786)
Fax: 1 800 96 FESTO (1 800 963 3786)
Email: customer.service@us.festo.com

Technical Support:
Tel: 1 866 GO FESTO (1 866 463 3786)
Fax: 1 800 96 FESTO (1 800 963 3786)
Email: product.support@us.festo.com