

Planar surface gantries EXCH



Planar surface gantries EXCH

Key features

At a glance

General

- Optimum dynamic response when compared with other Cartesian gantry systems
- The drive concept ensures low moving dead weight
- Flat system design
- Perfectly matched drive and controller package
- High acceleration in both axial directions

Application examples

- Fast repositioning of parts and modules in a large, rectangular working space, e.g.:
 - Sorting
 - Loading and unloading
 - Gluing and cutting

Operational principle

A slide is moved in a two-dimensional space (X/Y-axis) via a toothed belt. The system is powered by 2 fixed motors. The motors are coupled to the

toothed belt. The belt is guided via pulleys so that the slide can move to any position in a working space when the motors are actuated accordingly.

When using attachment components, additional processes can be carried out by independent Z-axes.

		Motor 1		
Motor 2				

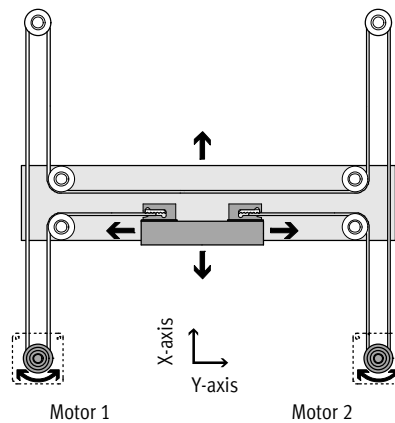

Type		EXCH-40	EXCH-60
Guide		Recirculating ball bearing guide	
Stroke of the			
X-axis	[mm]	200 ... 2000	500 ... 2500
Y-axis	[mm]	200 ... 1000	500 ... 1500
Nominal load at max. dynamic response ¹⁾	[kg]	4	6
Repetition accuracy ²⁾	[mm]	±0.1	

1) Nominal load = tool load (attachment component (Z-axis) + gripper, for example) + working load
 2) The repetition accuracy relates to the centre point of the slide.

Planar surface gantries EXCH

Key features

Motor attachment variants

EXCH-...-B – Motor underneath

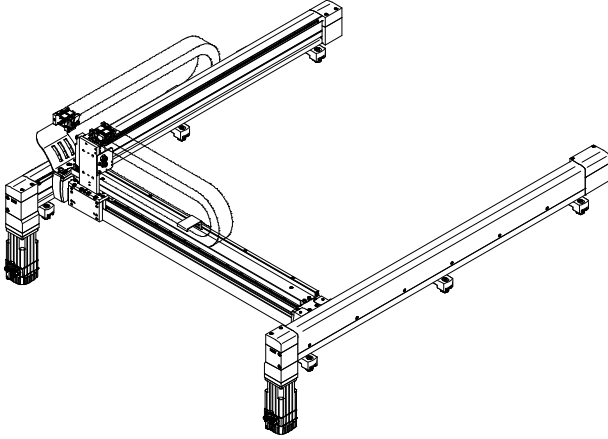

EXCH-...-T – Motor on top

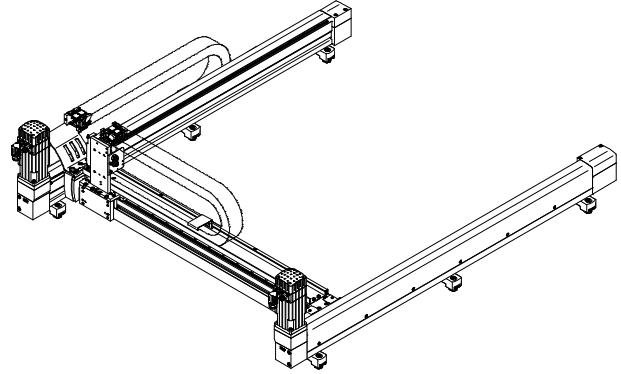

Mounting positions

Horizontal

- Installation always has energy chain at the top

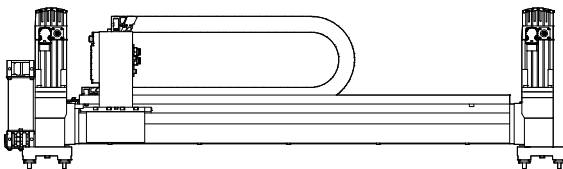

Vertical

- Only the X-axes may be installed vertically
- Motors must be at the top so that the energy chain can hang freely
- In combination with a control cabinet, the integrated safety switching device with power failure detection (order code S2) must be ordered
- Only in combination with the more powerful motors
 - EXCH-40: order code AB2
 - EXCH-60: order code AB3
- Only use motors with brake
- Braking resistors are essential

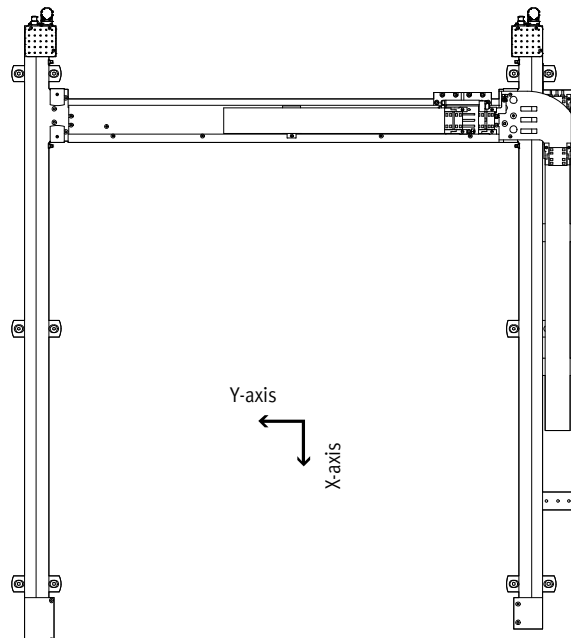

 Note

During commissioning, the motor brake must be released for safety purposes. We recommend the teach

pendant CDSA (→ modular product system) for this purpose.

Planar surface gantries EXCH

Key features

Selection of attachment components (Z-axis)

Without attachment component

The following are already installed on delivery:

- 1 2 supply ports for e.g. Z-axis
- 2 Multi-pin plug distributor (6-way) for bundling signals:
 - e.g. proximity sensor

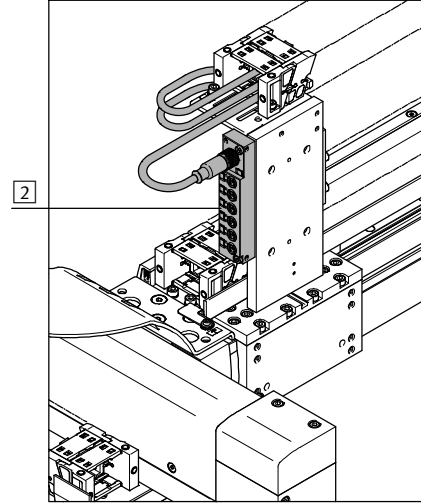
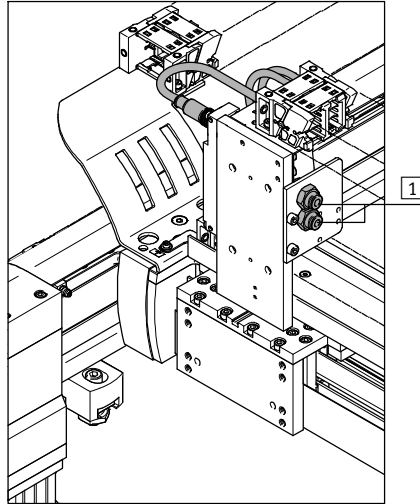

Attachment component, pneumatic (mini slide DGSL)

The following are already installed on delivery:

- 1 Solenoid valve for controlling the drive
- 2 1 supply port for e.g. gripper
- 3 Multi-pin plug distributor (6-way) for bundling signals:
 - For mini slide DGSL:
 - 2 proximity sensors
 - 1 solenoid valve
 - 3 ports are available
- 4 Proximity sensor for sensing the end positions

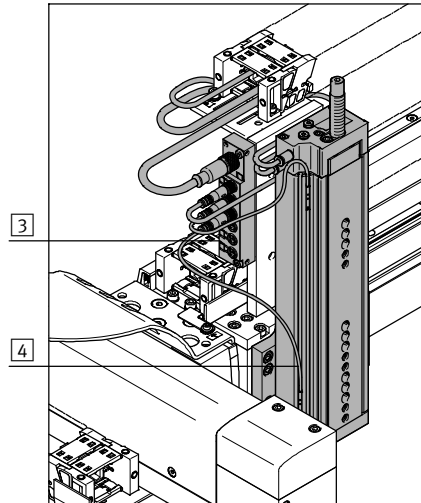
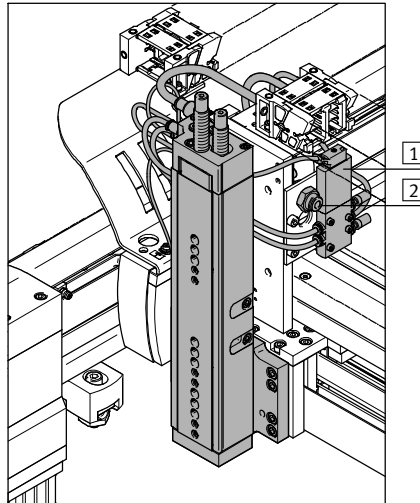

Attachment component, electric (mini slide EGSL)

The following are already installed on delivery:

- 1 2 supply ports for e.g. gripper
- 2 Multi-pin plug distributor (6-way) for bundling signals:
 - e.g. proximity sensor

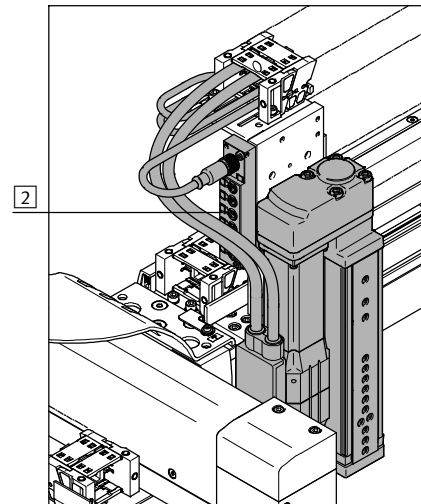
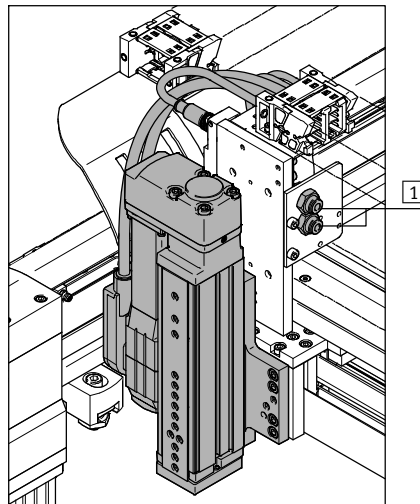

More information → 18

Planar surface gantries EXCH

Key features

Control systems CMCA

A suitable control system CMCA (control cabinet) that is perfectly matched to the planar surface gantry EXCH can be ordered using the modular product system → 32.

This is available in three versions:

- Mounting plate
- Mounting plate in a control cabinet housing
- Mounting plate in a control cabinet housing with base

The control system includes the multi-axis controller CMXR and motor controller CMMP required for activation. There is also an integrated safety circuit, which together with the teach pendant CDSA realises the basic functionality.

The version with the control cabinet housing also features control elements and fans in the door.

Mounting plate in the control cabinet housing

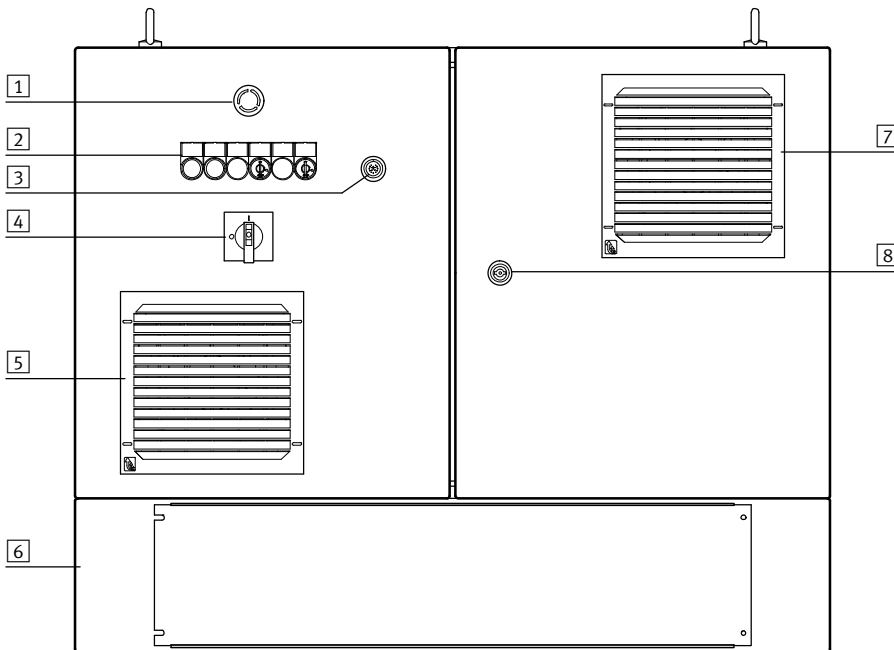

- 1 Emergency stop switch
- 2 Control and signal elements
- 3 Connection for teach pendant CDSA
- 4 Power switch
- 5 Cover for control cabinet fan
- 6 Base (optional)
- 7 Cover for outlet filter
- 8 Lock for control cabinet doors

Mounting plate

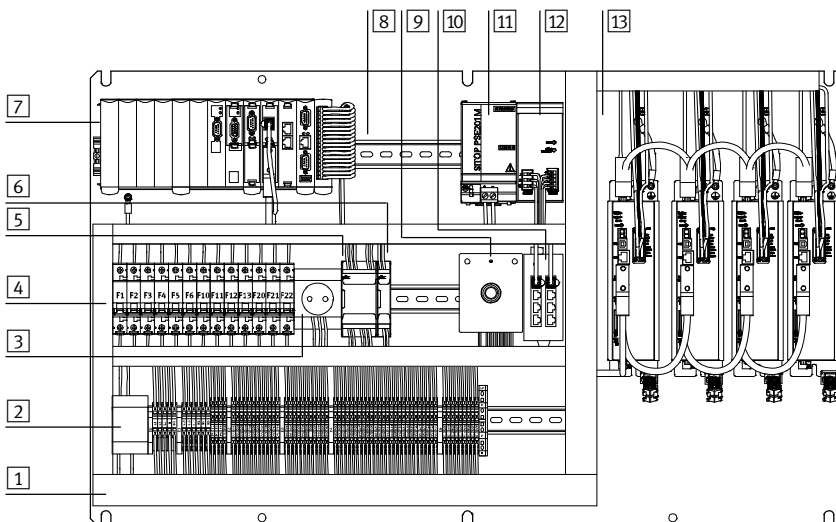

- 1 Terminal strips X0 ... X6
- 2 Monitoring module for power failure detection
- 3 Socket with earthing contact
- 4 Fuses F1 ... F22
- 5 Safety circuit control system
- 6 Extension for safety circuit control system
- 7 Multi-axis control system
- 8 Additional peripheral modules possible
- 9 Port for CDSA
- 10 Ethernet switch
- 11 Buffer module 24 V DC
- 12 Power supply unit 24 V DC
- 13 Motor controller

Planar surface gantries EXCH

Type codes

		EXCH	-	40	-	750	-	400	-	KF	-	AB1	-	B	-	L	-	P2	-	CC	
Type																					
EXCH	Planar surface gantry																				
Size																					
Stroke of the X-axis [mm]																					
Stroke of the Y-axis [mm]																					
Guide																					
KF	Recirculating ball bearing guide																				
Motor type																					
W	Without motor																				
AB1	Servo motor, size 70, with brake																				
AB2	Servo motor, size 100, with brake																				
AB3	Servo motor, size 140, with brake																				
AS1	Servo motor, size 70																				
AS2	Servo motor, size 100																				
AS3	Servo motor, size 140																				
Motor attachment position																					
B	Bottom																				
T	Top																				
Energy chain connection side																					
L	Left-hand																				
Attachment components																					
T0	Without attachment components																				
E1	Electric lifter, 100 mm stroke																				
E2	Electric lifter, 200 mm stroke																				
P1	Pneumatic lifter, 50 mm stroke																				
P2	Pneumatic lifter, 100 mm stroke																				
P3	Pneumatic lifter, 150 mm stroke																				
P4	Pneumatic lifter, 200 mm stroke																				
Control system																					
-	Without control system																				
C	Mounting plate																				
CC	Control cabinet																				
CS	Control cabinet with base																				

Planar surface gantries EXCH

Type codes

		-	C2	-	B1	-		-	B	-	5K	-		-	DE
Multi-axis controller															
-	Without controller														
C2	CMXR-C2, with integrated PLC														
Motor controller															
-	Without														
B1	2x CMMP-AS-C5-3A, without electric front unit														
B2	2x CMMP-AS-C5-3A, 1x CMMP-AS-C2-3A, for front unit (1 electric axis)														
B3	2x CMMP-AS-C5-3A, 2x CMMP-AS-C2-3A, for front unit (2 electric axes)														
B6	2x CMMP-AS-C5-11A-P3, without electric front unit														
B7	2x CMMP-AS-C5-11A-P3, 1x CMMP-AS-C2-3A, for front unit (1 electric axis)														
B8	2x CMMP-AS-C5-11A-P3, 2x CMMP-AS-C2-3A, for front unit (2 electric axes)														
Safety technology															
-	Without safety switching device														
K1	Integrated safety switching device														
S2	Integrated safety switching device with power failure detection														
Operator terminal															
-	Without														
B	With teach pendant CDSA														
Cable length [m]															
-	Without														
5K	5 m														
10K	10 m														
Mounting kit															
-	With adjusting kit														
P	With mounting kit														
Document language															
DE	German														
EN	English														
ES	Spanish														
FR	French														
IT	Italian														
RU	Russian														
ZH	Chinese														

 Note
Ordering data → 32

Planar surface gantries EXCH

Peripherals overview

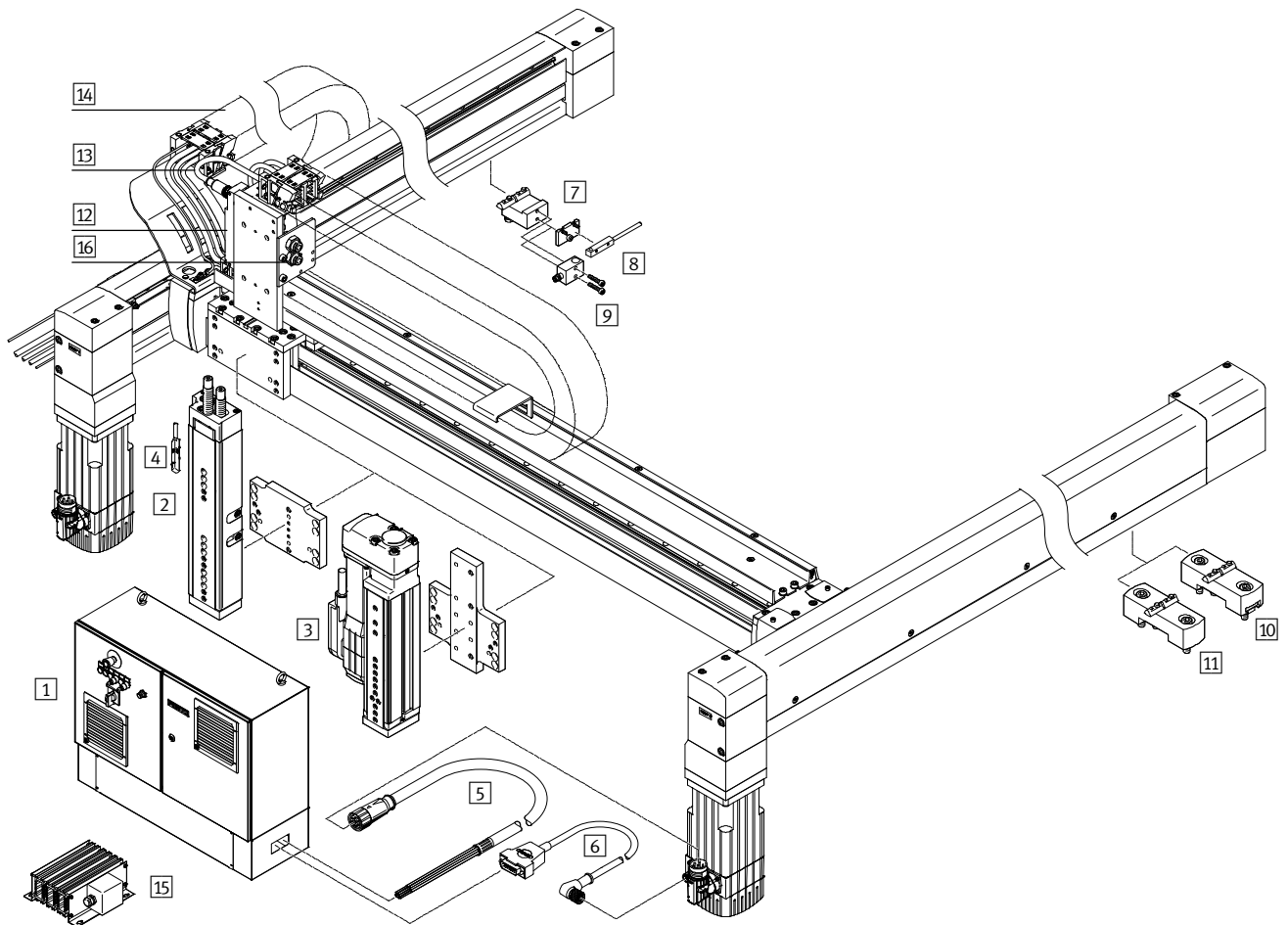

Proximity sensor for sensing the position of the slide on the Y-axis

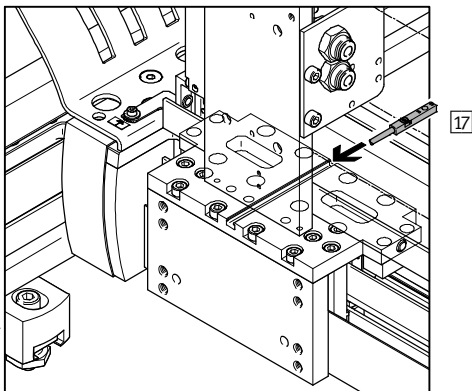

Planar surface gantries EXCH

Peripherals overview



Attachments and accessories		
Type	Description	→ Page/Internet
1 Control system CMCA	<ul style="list-style-type: none"> For controlling the planar surface gantry 	cmca
2 Mini slide P1, P2, P3, P4	<ul style="list-style-type: none"> Pneumatic attachment component (mini slide DGSL) for the Z-axis 	dgsl
3 Mini slide E1, E2	<ul style="list-style-type: none"> Electric attachment component (mini slide EGSL) with motor cable NEBM and encoder cable NEBM for the Z-axis 	egsl
4 Proximity sensor SME-10M	<ul style="list-style-type: none"> For position sensing on the Z-axis Included in the scope of delivery of the planar surface gantry EXCH-...-P... 	35
5 Motor cable NEBM-M23G6	<ul style="list-style-type: none"> Connecting cable between motor and motor controller CMMP-AS Included in the scope of delivery of the planar surface gantry EXCH-...-A... 	nebm
6 Encoder cable NEBM-M12W8	<ul style="list-style-type: none"> Connecting cable between encoder and motor controller CMMP-AS Included in the scope of delivery of the planar surface gantry EXCH-...-A... 	nebm
7 Sensor mounting EAPR	<ul style="list-style-type: none"> For mounting the proximity sensors SIES-Q8B, SIES-V3B on the X-axis Not included in the scope of delivery of the planar surface gantry 	22
8 Proximity sensor SIES-Q8B	<ul style="list-style-type: none"> For position sensing on the X-axis Not included in the scope of delivery of the planar surface gantry 	35
9 Proximity sensor SIES-V3B	<ul style="list-style-type: none"> For position sensing on the X-axis Not included in the scope of delivery of the planar surface gantry 	35
10 Adjusting kit EADC-12	<ul style="list-style-type: none"> Height-adjustable mounting kit for the planar surface gantry Included in the scope of delivery of the planar surface gantry. If no adjusting kit is selected in the modular product system, the mounting kit will automatically be delivered 	30
11 Mounting kit EAHM-E12	<ul style="list-style-type: none"> Non-height-adjustable mounting kit for the planar surface gantry 	30
12 Multi-pin plug distributor NEDU	<ul style="list-style-type: none"> For connecting up to 6 inputs/outputs Included in the scope of delivery of the planar surface gantry 	nedu
13 Plug socket with cable SIM	<ul style="list-style-type: none"> Connecting cable between multi-pin plug distributor and controller Included in the scope of delivery of the planar surface gantry 	sim
14 Energy chain	<ul style="list-style-type: none"> For EXCH-40: type IGUS E6.29.040.075.0 For EXCH-60: type IGUS E6.35.050.075.0 	–
15 Braking resistor CACR-KL2	<ul style="list-style-type: none"> Essential in the case of a vertical mounting position 	35
16 Plastic tubing PUN-H-6x1	<ul style="list-style-type: none"> Two tubes are connected to the bulkhead fittings and routed in the energy chains on delivery (for pneumatic Z-axis, one tube on the valve and one on the bulkhead fitting) 	pun
17 Proximity sensor SIES-8M	<ul style="list-style-type: none"> For position sensing on the Y-axis Not included in the scope of delivery of the planar surface gantry 	35
– Motor cable NEBM-T1G7	<ul style="list-style-type: none"> Connecting cable between motor on the Z-axis and motor controller CMMP-AS Included in the scope of delivery of the planar surface gantry EXCH-...-E... 	nebm
Encoder cable NEBM-T1G8	<ul style="list-style-type: none"> Connecting cable between encoder on the Z-axis and motor controller CMMP-AS Included in the scope of delivery of the planar surface gantry EXCH-...-E... 	nebm
Teach pendant CDSA	<ul style="list-style-type: none"> For operating the multi-axis controller CMXR Available with or without teach pendant 	cdsa

Planar surface gantries EXCH

Technical data

Size
40, 60



General technical data			
Size		40	60
Design		Planar surface gantry	
Guide		Recirculating ball bearing guide	
Stroke of the			
X-axis	[mm]	200 ... 2000	500 ... 2500
Y-axis	[mm]	200 ... 1000	500 ... 1500
Z-axis	[mm]	50, 100, 150, 200	
EXCH-...-E1	[mm]	100	
EXCH-...-E2	[mm]	200	
EXCH-...-P1	[mm]	50	
EXCH-...-P2	[mm]	100	
EXCH-...-P3	[mm]	150	
EXCH-...-P4	[mm]	–	
Nominal load at max. dynamic response ¹⁾	[kg]	4	6
Max. torque ²⁾	[Nm]	→ 14	
Max. no-load torque ²⁾³⁾	[Nm]	→ 15	
Max. acceleration ⁴⁾			
Horizontal	[m/s ²]	50	
Vertical	[m/s ²]	30	
Max. speed ⁴⁾			
Horizontal	[m/s]	5	
Vertical	[m/s]	4	3
Repetition accuracy	[mm]	±0.1	
Mounting position ⁵⁾		Vertical or horizontal	
Type of mounting		Mounting kit, adjusting kit	

- 1) Nominal load = tool load (attachment component (Z-axis) + gripper, for example) + working load
- 2) These values must also be complied with during installation of third-party motors
- 3) At v=0.2 m/s and 45° travel.
- 4) These data apply only under ideal conditions.
For a precise configuration please consult a sales engineer from Festo.
More information → 15
- 5) Vertical installation only permitted with: motors with brake and braking resistors

Factoring in software end positions

When selecting the strokes for the X- and Y-axis, the dimension L3 for the software end positions must be taken into account in addition to the working stroke L2. This dimension is freely selectable.

Setting pieces with L3 = 30 mm are included in the scope of delivery of the planar surface gantry.

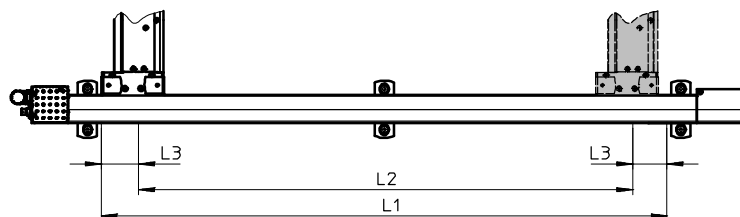

Stroke L1 = working stroke L2 + 2x software end position L3

Planar surface gantries EXCH

Technical data

Operating and environmental conditions		
Size	40	60
Degree of protection	IP40	
Ambient temperature ¹⁾	[°C]	+10 ... +50
Storage temperature	[°C]	-10 ... +60
Relative air humidity	[%]	0 ... 90 (non-condensing)
Noise level	[dB(A)]	74
Duty cycle	[%]	100
CE marking (see declaration of conformity)	To EC Machinery Directive	

1) Note operating range of proximity sensors and motors

Materials

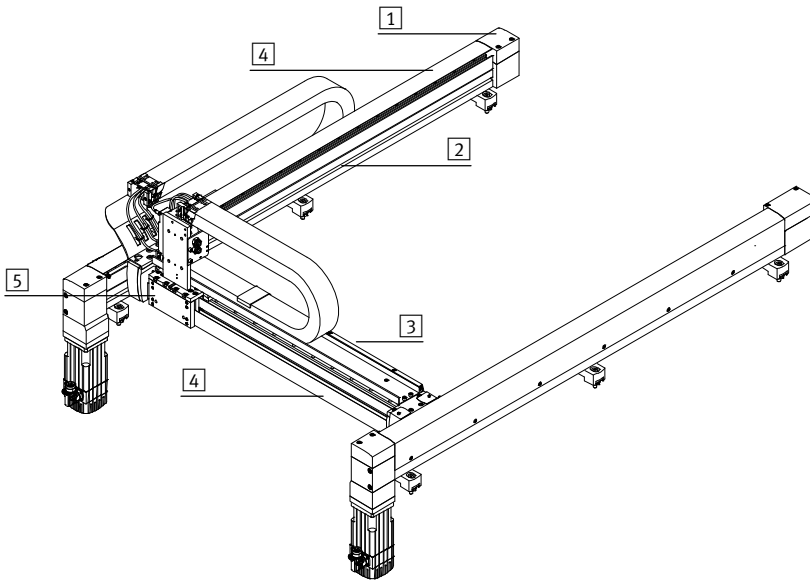

Size	40	60
1 Drive and end caps	Aluminium	
2 Profiles of the X-axis	Aluminium	
3 Profile of the Y-axis	Aluminium	
4 Cover		
X-axis	Aluminium	
Y-axis	Aluminium	
5 Slide	Aluminium	
- Coupling	Aluminium with elastomer ring gear	Clamping hub: aluminium Expanding mandrel hub: stainless steel Collar: elastomer
Guide	Steel	
Drive pinion	Steel	
Ball bearings	Steel	
Toothed belt	PU with steel cord	
Note on materials	RoHS-compliant	
	Contains PWIS (paint-wetting impairment substances)	

Planar surface gantries EXCH

Technical data

Weight [kg]		
Size	40	60
Product weight with 0 mm stroke (without nominal load, motors, axial kits, mounting kits)		
X-axis and Y-axis	16.6	37.9
Y-axis (without slide)	6.0	11.5
Additional weight per 100 mm stroke		
X-axis	1.69	2.21
Y-axis	0.81	0.99
Axial kit ¹⁾		
For EMMS-AS-70/-100	0.66	1.33
For EMMS-AS-100/-140	1.02	2.06
Motor ¹⁾		
Without brake		
EXCH-...-AS1	2.7	–
EXCH-...-AS2	4.8	6.9
EXCH-...-AS3	–	9.6
With brake		
EXCH-...-AB1	2.9	–
EXCH-...-AB2	5.3	7.5
EXCH-...-AB3	–	10.4
Attachment component (Z-axis)		
Electrical		
EXCH-...-E1	3.4	5.3
EXCH-...-E2	4.0	6.2
Pneumatic		
EXCH-...-P1	1.8	2.7
EXCH-...-P2	2.4	3.6
EXCH-...-P3	2.7	4.3
EXCH-...-P4	–	5.0
Mounting kit for X-axis		
Adjusting kit ¹⁾	0.78	0.89
Mounting kit ¹⁾	0.33	0.37

1) Weight per component

Planar surface gantries EXCH

Technical data

FESTO

Acceleration a as a function of the nominal load and stroke of the Y-axis

EXCH-40

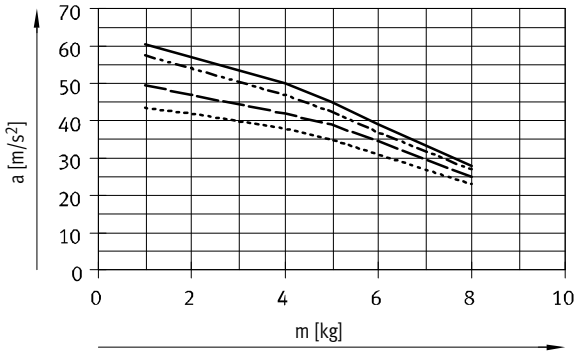

- Stroke, Y-axis = 400 mm
- - - Stroke, Y-axis = 500 mm
- · - Stroke, Y-axis = 750 mm
- · · Stroke, Y-axis = 1000 mm

EXCH-60

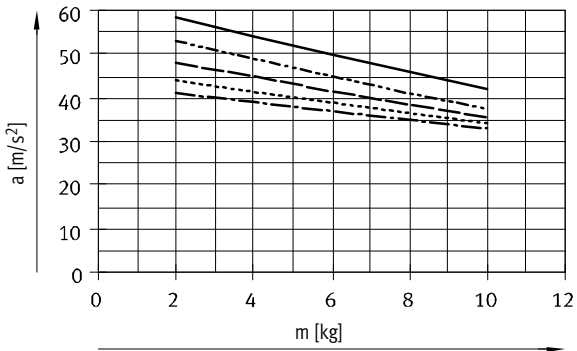

- Stroke, Y-axis = 500 mm
- - - Stroke, Y-axis = 750 mm
- · - Stroke, Y-axis = 1000 mm
- · · Stroke, Y-axis = 1250 mm
- - - Stroke, Y-axis = 1500 mm

Planar surface gantries EXCH

Technical data

Torque M as a function of rotational speed n

Typical motor characteristic curve with nominal voltage and optimal motor controller. The torque may briefly exceed the nominal torque. The rms value of the torque for the respective positioning cycle must remain below the nominal torque.

EXCH-40

In conjunction with:
EMMS-AS-70-M-LS-RM, EMMS-AS-70-M-LS-RMB
and CMMP-AS-C5-3A

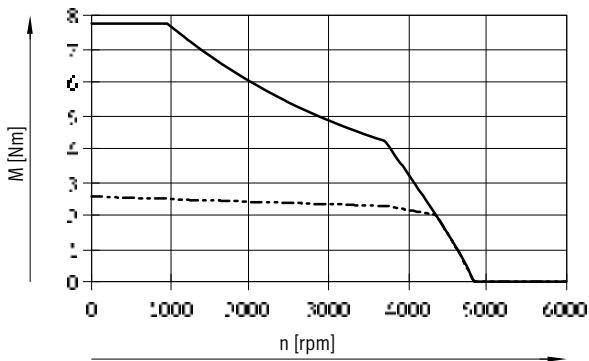

— Max. torque
- - - Nominal torque

In conjunction with:
EMMS-AS-100-S-HS-RM, EMMS-AS-100-S-HS-RMB
and CMMP-AS-C5-11A

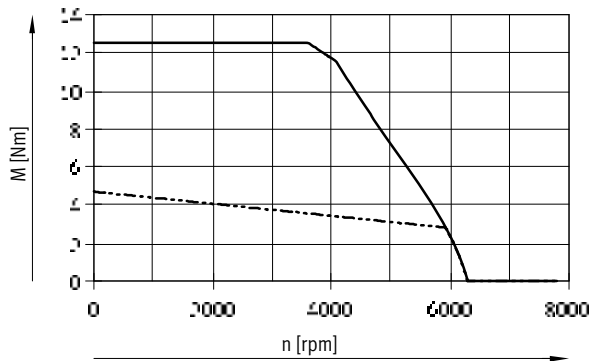

— Max. torque
- - - Nominal torque

EXCH-60

In conjunction with:
EMMS-AS-100-M-HS-RM, EMMS-AS-100-M-HS-RMB
and CMMP-AS-C5-11A

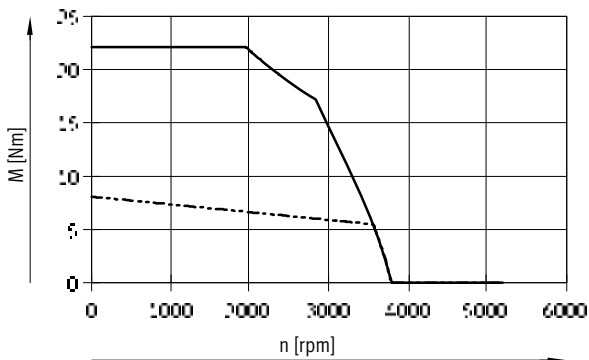

— Max. torque
- - - Nominal torque

In conjunction with:
EMMS-AS-140-S-HV-RM, EMMS-AS-140-S-HV-RMB
and CMMP-AS-C5-11A

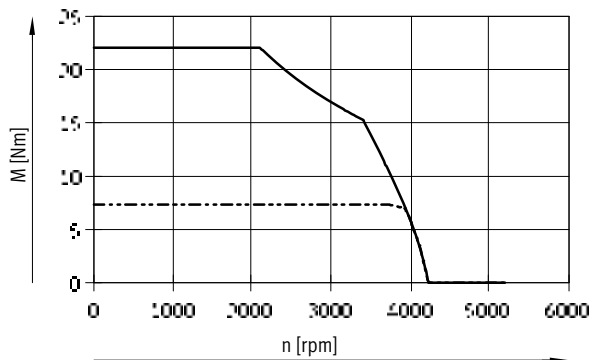

— Max. torque
- - - Nominal torque

Planar surface gantries EXCH

Technical data

No-load torque M as a function of speed n

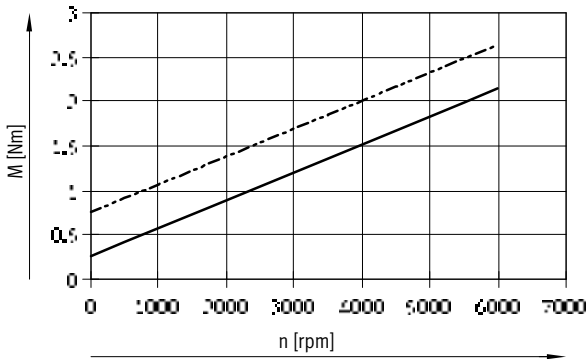

— EXCH-40
 - - - EXCH-60

Characteristic load values

The following information applies for a horizontal mounting position. For vertical installation positions, please get in touch with your local contact at Festo.

The centre of gravity of the slide is at the height of the slide in the Z-direction and in the centre of the slide in the X-/Y-directions.

The system is subject to the greatest load in the case of 45° travel. The following data apply in this case:

Formula for calculating the required torque M and the required nominal rotary speed n

For EXCH-40:

$$M_{45^\circ} = a \times (9.79 \times m_L + 4.89 \times m_{Ay} + 10.21 \times J_m + 19.58) \times 10^{-3} + M_R$$

$$n_{45^\circ} = 975 \times v$$

For EXCH-60:

$$M_{45^\circ} = a \times (14.07 \times m_L + 7.03 \times m_{Ay} + 7.11 \times J_m + 49.24) \times 10^{-3} + M_R$$

$$n_{45^\circ} = 679 \times v$$

- a = acceleration [m/s²]
- v = speed [m/s]
- m_{Ay} = product weight at the Y-axis [kg]
→ 12
- m_L = attachment component (Z-axis) [kg] with payload
- J_m = moment of inertia of motor [kgcm²]
→ table below
- M_R = no-load torque [Nm]
→ 15
- n_{45°} = nominal rotary speed for 45° travel [rpm]

Allocation of planar surface gantry to servo motor for X-/Y-axis

Planar surface gantry	Motor	Moment of inertia of motor [kgcm ²]
EXCH-40-...-AB1	EMMS-AS-70-M-LS-RMB	0.68
EXCH-40-...-AS1	EMMS-AS-70-M-LS-RM	0.611
EXCH-40-...-AB2 ¹⁾	EMMS-AS-100-S-HS-RMB	3.085
EXCH-40-...-AS2	EMMS-AS-100-S-HS-RM	2.529
EXCH-60-...-AB2	EMMS-AS-100-M-HS-RMB	5.285
EXCH-60-...-AS2	EMMS-AS-100-M-HS-RM	4.729
EXCH-60-...-AB3 ¹⁾	EMMS-AS-140-S-HV-RMB	9.271
EXCH-60-...-AS3	EMMS-AS-140-S-HV-RM	8.189

1) Essential when the planar surface gantry is mounted vertically.

Planar surface gantries EXCH

Technical data

Sample calculation

Given:

Planar surface gantry
 EXCH-40-1000-500-KF-AS2-B-L-E1-...
 with attached motor
 EMMS-AS-100-S-HS-RMB

$a_{max} = 25 \text{ m/s}^2$

$v_{max} = 2 \text{ m/s}$

Payload = 0.5 kg

Attachment component Z-axis: EGSL-BS-45-100-3P

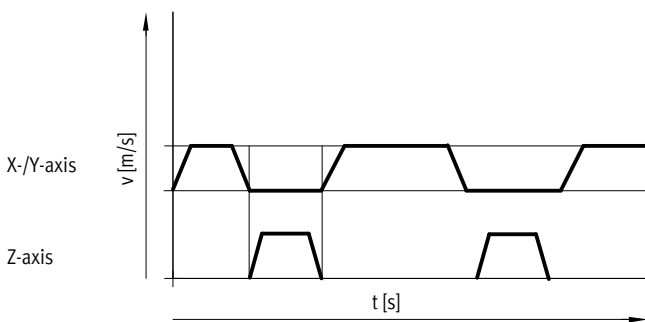

Calculation:

1. What is the max. acceleration permitted by the mechanical system?

Moving mass m_l at the Y-axis:

Z-axis 3.40 kg
 Payload 0.50 kg
 = 3.90 kg

Stroke of the Y-axis:
 500 mm

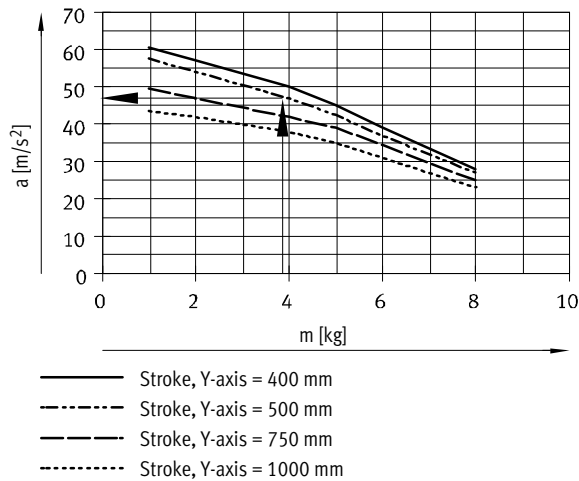

Result:

In the case of a moving mass m_l of 3.9 kg, the maximum permissible acceleration is 46 m/s^2 .
 The requested acceleration of 25 m/s^2 is thus permissible.

Planar surface gantries EXCH

Technical data

Sample calculation

2. Is the attached motor sufficient for this load?

Given:

$$a_{max} = 25 \text{ m/s}^2$$

$$v_{max} = 2 \text{ m/s}$$

$$m_{Ay} = 10.05 \text{ kg}$$

$$m_L = 3.90 \text{ kg}$$

$$J_m = 3.085 \text{ kgcm}^2$$

$$M_{45^\circ} = a \times (9.79 \times m_L + 4.89 \times m_{Ay} + 10.21 \times J_m + 19.58) \times 10^{-3} + M_R$$

$$n_{45^\circ} = 975 \times v$$

a = acceleration [m/s²]

v = speed [m/s]

m_{Ay} = product weight at the Y-axis [kg]
→ 12

m_L = attachment component (Z-axis) [kg]
with payload

J_m = moment of inertia of motor [kgcm²]

→ 15

M_R = no-load torque [Nm]

→ 15

n_{45°} = nominal rotary speed for 45° travel [rpm]



Note

These requirements for the dynamic response apply to 45° travel. For travel only in the X- or Y-direction, the dynamic values may be higher.

Determination of M_R:

$$n_{45^\circ} = 975 \times 2 \text{ m/s} = 1950 \text{ 1/min}$$

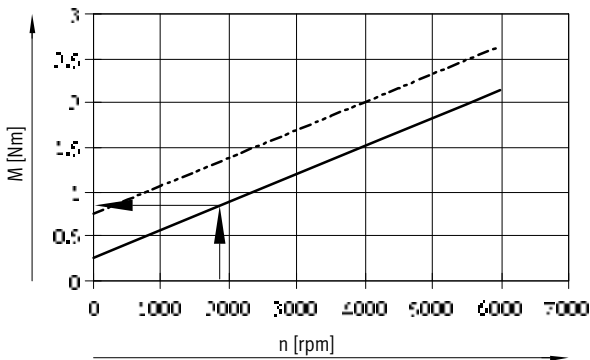

No-load torque:

— EXCH-40

- - - EXCH-60

$$M_R = 0.9 \text{ Nm}$$

$$M_{45^\circ} = a \times (9.79 \times m_L + 4.89 \times m_{Ay} + 10.21 \times J_m + 19.58) \times 10^{-3} + M_R$$

$$M_{45^\circ} = 25 \frac{\text{m}}{\text{s}^2} \times (9.79 \times 3.90 \text{ kg} + 4.89 \times 10.05 \text{ kg} + 10.21 \times 3.085 \text{ kgcm}^2 + 19.58) \times 10^{-3} + 0.9 \text{ Nm} = 4.36 \text{ Nm}$$

Result:

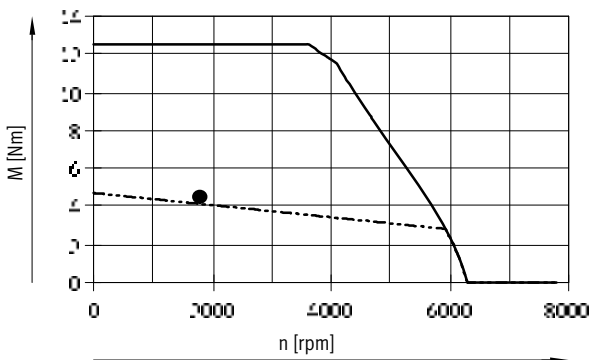

— Max. torque

- - - Nominal torque

The value for the torque is above the nominal torque and below the maximum torque.

This torque is only required in the acceleration phases.

The design is fine, depending on the travel profile.

Planar surface gantries EXCH

Technical data

Selection of attachment components

The following variants for the Z-axis can optionally be ordered using the modular product system → 32:

- Without attachment component
- With pneumatic attachment component (mini slide DGSL)
- With electric attachment component (mini slide EGSL)

The drives are delivered fully connected. Cables and tubing are routed as far as the output of the energy chain (X-axis).

EXCH-...-TO... (without attachment component)

The following are preinstalled:

- 2 supply ports for e.g. Z-axis
- Multi-pin plug distributor for bundling signals:
 - e.g. proximity sensor

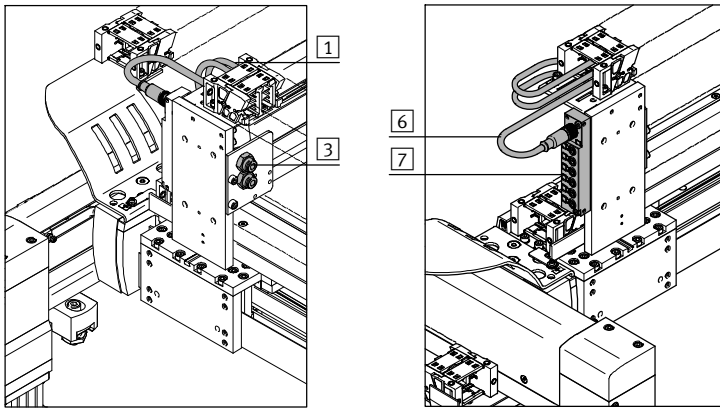

Components affected	Number of components
1 Tubing	2
3 Bulkhead fitting	2
6 Plug socket with cable	1
7 Multi-pin plug distributor (6-way)	1
– Earthing cable	2

EXCH- ... -P... (pneumatic attachment component)

The following are preinstalled:

- Solenoid valve for controlling the drive
- 1 supply port for e.g. gripper
- Proximity sensor for end position sensing
- Multi-pin plug distributor for bundling signals:
 - For mini slide DGSL:
 - 2 proximity sensors
 - 1 solenoid valve
 - 3 ports are available

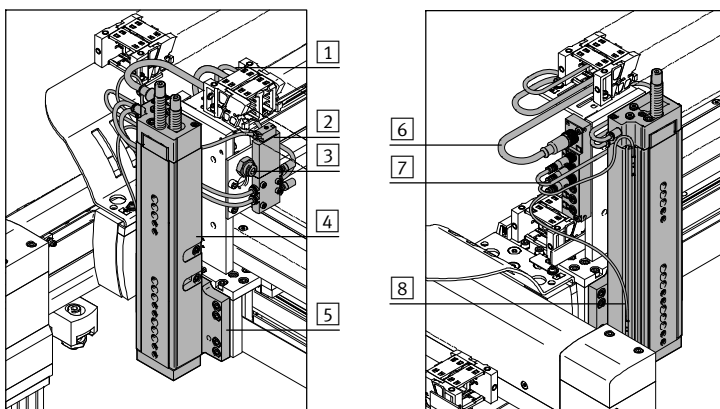

Components affected	Number of components
1 Tubing	2
2 Solenoid valve	1
3 Bulkhead fitting	1
4 Mini slide DGSL-...-Y3A ¹⁾	1
5 Adapter plate	1
6 Plug socket with cable	1
7 Multi-pin plug distributor (6-way)	1
8 Proximity sensor	2
– Earthing cable	2

1) For EXCH-40, the mini slide DGSL-16 is used with progressive shock absorbers. For EXCH-60, the mini slide DGSL-20 is used with progressive shock absorbers. More information → Internet: dgs1

Planar surface gantries EXCH

Technical data

Selection of attachment components

EXCH-...-E... (electrical attachment component)

The following are preinstalled:

- 2 supply ports for e.g. gripper
- Multi-pin plug distributor for bundling signals:
 - e.g. proximity sensor

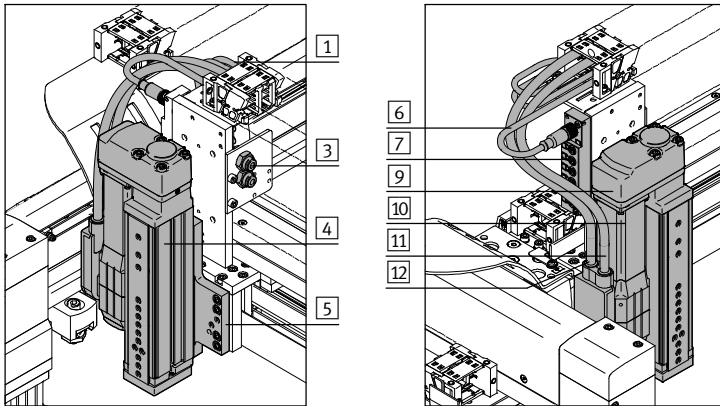

Components affected	Number of components
1 Tubing	2
3 Bulkhead fitting	2
4 Mini slide EGSL ¹⁾	1
5 Adapter plate	1
6 Plug socket with cable	1
7 Multi-pin plug distributor (6-way)	1
9 Parallel kit	1
10 Motor	1
11 Motor cable	1
12 Encoder cable	1
- Earthing cable	2

1) For EXCH-40, the mini slide EGSL-45 is used with a lead of 10 mm.
 For EXCH-60, the mini slide EGSL-55 is used with a lead of 12.7 mm.
 More information → Internet: egsl

Mounting position of the Z-axis

Owing to manufacturing tolerances and the backlash in the guides, the angle between the X- and Z-axes may not be exactly 90° in certain circumstances.

Max. deviation:

EXCH-40: $\alpha = \pm 1.1^\circ$

EXCH-60: $\alpha = \pm 2.1^\circ$

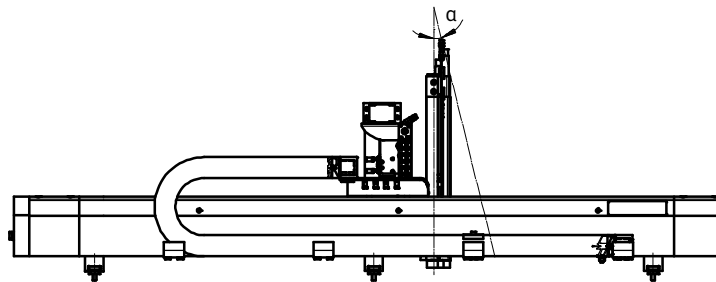

Selection of cable lengths

2 cable lengths (5 m or 10 m) can be selected using the modular product system → 32. This specification relates to the output of the energy chain at the X-axis (dimension L) and describes the minimum length by which the cables and tubing protrude. The selected length applies to the following components:

- Tubing
- Plug sockets with cable
- Motor cables
- Encoder cables
- Earthing cables

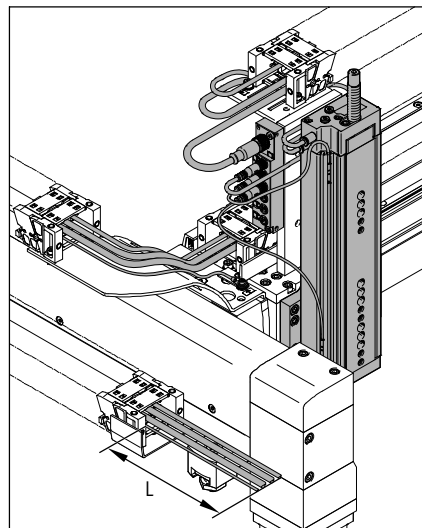

Planar surface gantries EXCH

Technical data

Number of profile mountings

Irrespective of the mounting position, a different number of profile mountings need to be used depending on

the stroke of the X-axis.
The item is delivered with the required number attached.

Stroke of the X-axis [mm]	Number of profile mountings per axis	
	EXCH-40	EXCH-60
200 ... 499	2	-
500 ... 899	2	-
900 ... 1799	3	-
1800 ... 2000	4	-
2000 ... 2500	-	4

Spacings of the profile mountings

The profile mountings must be uniformly spaced from one another by the distance l.

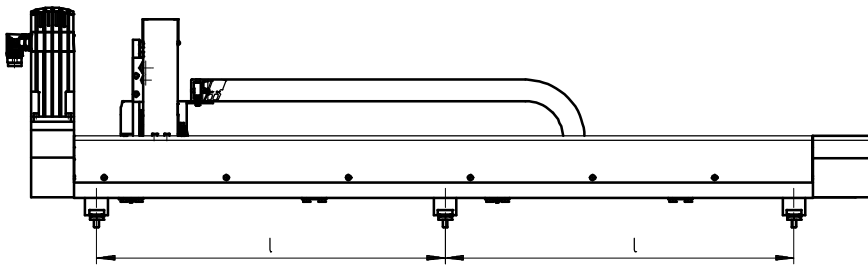

For EXCH-40

For EXCH-60

$$\text{Distance } l = \frac{\text{stroke} + 141}{n - 1}$$

$$\text{Distance } l = \frac{\text{stroke} + 328}{n - 1}$$

n = number of profile mountings per axis

Planar surface gantries EXCH

Technical data

FESTO

Pin allocations

Motors on the X-/Y-axis

Motor (M23, pins)

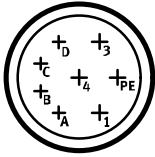

PIN	Function	Colour
1	U Phase U	BK (1)
PE	PE Protective earth	GNYE
3	W Phase W	BK (3)
4	V Phase V	BK (2)
A	M _{T+} Temperature sensor	WH
B	M _{T-} Temperature sensor	BN
C	BR+ Brake	GN
D	BR- Brake	YE

Encoder (M12, pins)

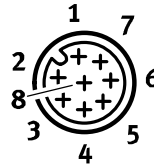

PIN	Function
1	-SENS
2	+SENS
3	DATA
4	DATA/
5	0 V
6	CLOCK/
7	CLOCK
8	UP

Motor on the Z-axis

Motor

Black plug connector

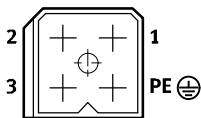

PIN	Function	Colour
1	Phase V	BK (2)
2	Phase W	BK (3)
3	Phase U	BK (1)
PE	PE Protective earth	GNYE

Temperature sensor and brake

Blue plug connector

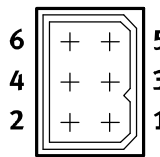

PIN	Function	Colour
1	M _{T+} Temperature sensor	WH
2	M _{T-} Temperature sensor	BN
3	BR+ Brake	GN
4	BR- Brake	YE
5	n.c.	-
6	n.c.	-

Encoder

Red plug connector

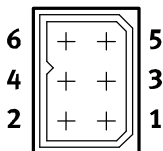

PIN	Function
1	DATA
2	DATA/
3	0 V
4	UP
5	CLOCK/
6	CLOCK

Encoder

Yellow plug connector

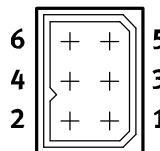

PIN	Function
1	-SENS
2	+SENS
3	n.c.
4	n.c.
5	n.c.
6	n.c.

Planar surface gantries EXCH

Technical data

Dimensions

Download CAD data → www.festo.com

EXCH-40-...-T – Motor attachment position on top

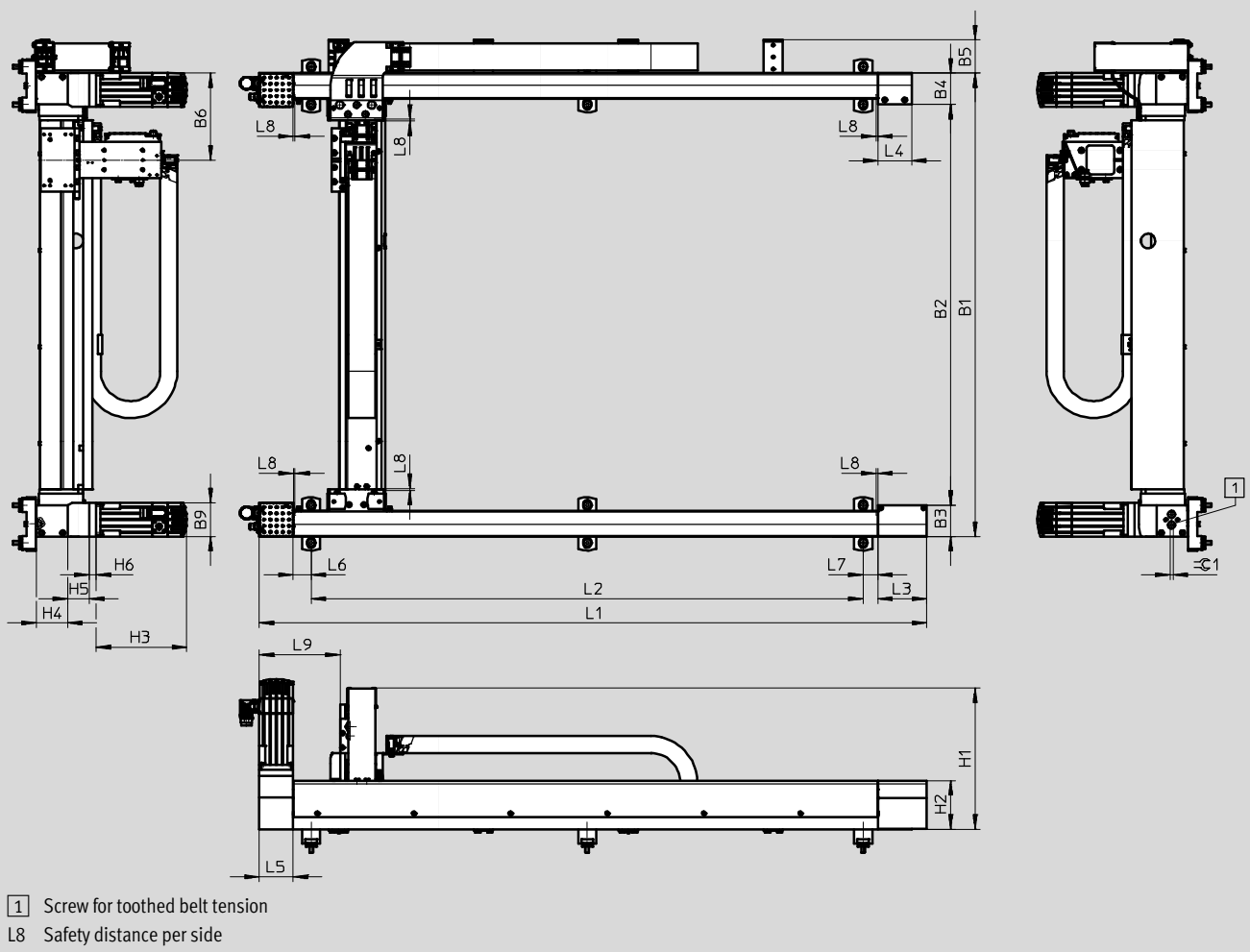

EXCH-40-...-B – Motor attachment position underneath

EXCH-40-... – Motor interface

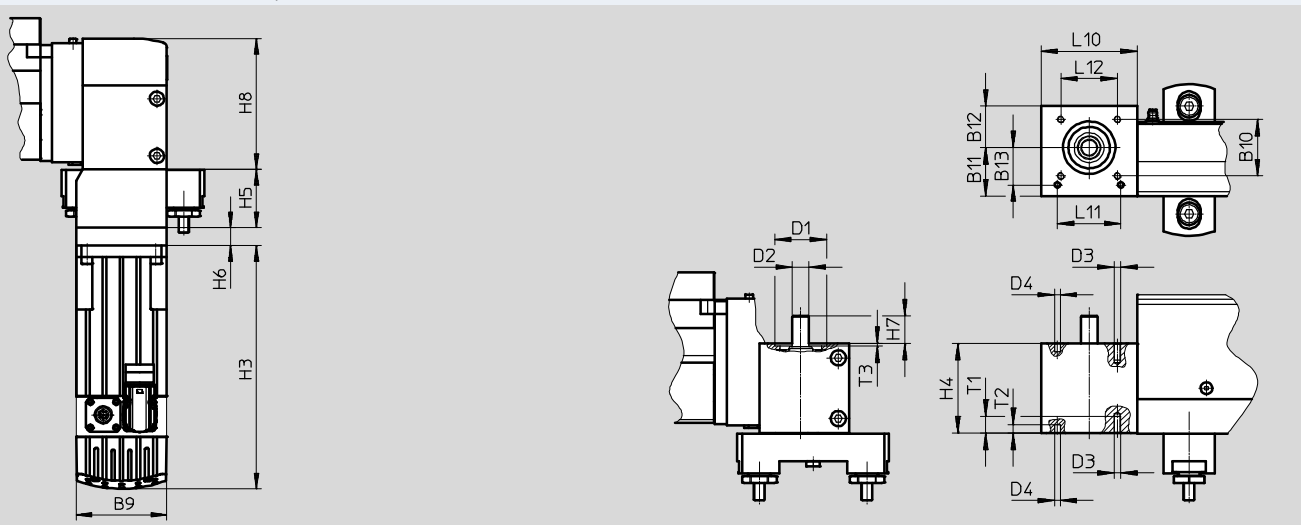

Planar surface gantries EXCH

Technical data

Dimensions

Download CAD data → www.festo.com

EXCH-40-... – Slide

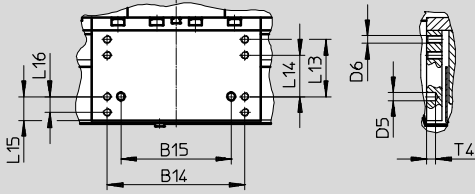

Type	B3	B4	B5	B6	B9	B10	B11	B12	B13	B14
									±0.05	±0.1
With EMMS-AS-70	65	65	69	179.9	70	41	35	30	27	106
With EMMS-AS-100	65	65	69	179.9	100.5					

Type	B15	D1	D2	D3	D4	D5	D6	H1	H2	H3
	±0.03	∅ H7	∅ H6		∅ H7	∅ H7				
With EMMS-AS-70	85	38	12	M5	4	6	M6	Approx. 293	100.8	187.3
With EMMS-AS-100										192.3

Type	H4	H5	H6	H7	H8	L3	L4	L5	L6	L7	L8	L9
With EMMS-AS-70	65	44.9	13.8	20	100.3	101	70	70	37.5	30.5	4	167.2
With EMMS-AS-100		57	20.1									

Type	L10	L11	L12	L13	L14	L15	L16	T1	T2	T3	T4	≅G1
		±0.03		±0.1	±0.1		±0.1					
With EMMS-AS-70	70	46	41	44	32	18.5	12	12	6	1.9	7	6
With EMMS-AS-100												

Stroke-dependent dimensions

Stroke of the X-axis	L1	L2	Stroke of the Y-axis	B1	B2
500	882	641	400	760	630
750	1132	891	500	860	730
1000	1382	1141	750	1100	980
1500	1882	1641	1000	1360	1230
200 ... 2000	382+stroke	→ 20	200 ... 1000	360+stroke	230+stroke

 Note

A different number of profile mountings is required depending on the stroke of the X-axis. The spacing between the profile mountings must always be the same (→ 20).

The tension of the toothed belt must be adjusted in preparation for commissioning. The tools required for this (e.g. frequency meter) are not included in the scope of delivery.

Planar surface gantries EXCH

Technical data

Dimensions

Download CAD data → www.festo.com

EXCH-60-...-T – Motor attachment position on top

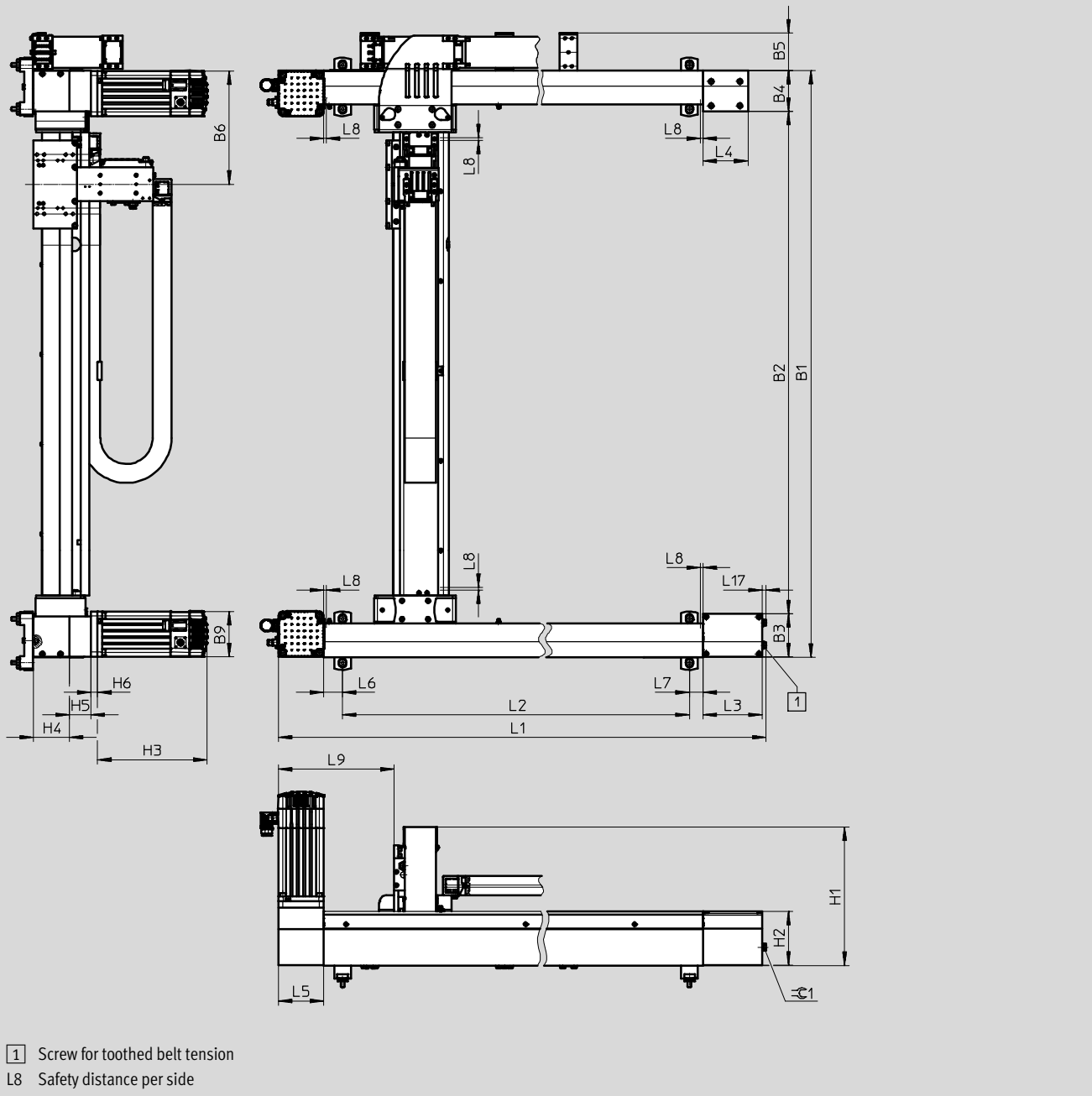

Planar surface gantries EXCH

Technical data

Type	B3	B4	B5	B6	B9	H1
With EMMS-AS-100	96.6	91	83.5	253.3	100.5	Approx. 310
With EMMS-AS-140					140.5	

Type	H2	H3	H4	H5	H6	L3	L4
With EMMS-AS-100	120.1	243.3	80.6	48	14.5	131.2	100
With EMMS-AS-140		209			24.5		

Type	L5	L6	L7	L8	L9	L17	≈C1
With EMMS-AS-100	100	42.5	30.5	6	257	8.9	13
With EMMS-AS-140							

Stroke-dependent dimensions

Stroke of the X-axis	L1	L2	Stroke of the Y-axis	B1	B2
750	1393	1078	500	1007	819
1000	1643	1328	750	1257	1069
1500	2143	1828	1000	1507	1319
2000	2643	2328	1250	1757	1569
500 ... 2500	643 + stroke	→ 20	1500	2007	1819
			500 ... 1500	507 + stroke	319 + stroke

Note

A different number of profile mountings is required depending on the stroke of the X-axis. The spacing between the profile mountings must always be the same (→ 20).

The tension of the toothed belt must be adjusted in preparation for commissioning. The tools required for this (e.g. frequency meter) are not included in the scope of delivery.

Planar surface gantries EXCH

Technical data

Dimensions

Download CAD data → www.festo.com

EXCH-60-...-B – Motor attachment position underneath

EXCH-60-... – Motor interface

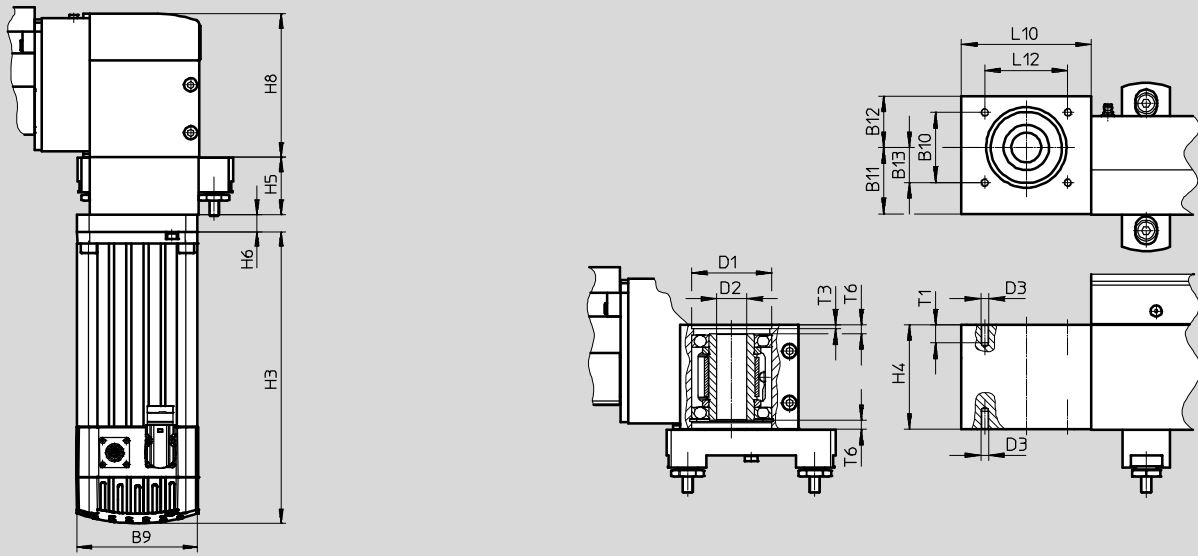

EXCH-60-... – Slide

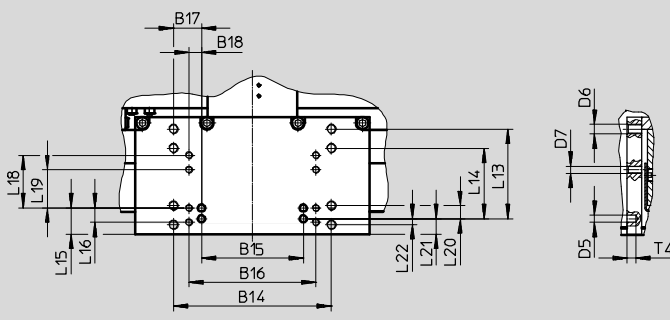

Type	B9	B10	B11	B12	B13	B14	B15	B16	B17
		±0.1			±0.05	±0.1	±0.03	±0.1	±0.1
With EMMS-AS-100	100.5	54	51	39.5	27	132	85	106	23.5
With EMMS-AS-140	140.5								

Type	B18	D1	D2	D3	D5	D6	D7	H3	H4	H5
	±0.1	∅ H7	∅ H7		∅ H7					
With EMMS-AS-100	10.5	62	23	M6	6	M8	M6	243.3	80.6	48
With EMMS-AS-140								209		

Type	H6	H8	L10	L12	L13	L14	L15	L16	L18
				±0.1	±0.1	±0.1		±0.1	±0.1
With EMMS-AS-100	14.5	119.6	100	64	75	59	22	12	44
With EMMS-AS-140	24.5								

Type	L19	L20	L21	L22	T1	T3	T4	T6
	±0.1	±0.1						
With EMMS-AS-100	32	11	13	5	14	3.1	7	6.9
With EMMS-AS-140								

Planar surface gantries EXCH

Technical data

Dimensions

Download CAD data → www.festo.com

EXCH-40-...-P...

EXCH-40-...-E...

With pneumatic attachment component (mini slide DGSL)

With electric attachment component (mini slide EGSL)

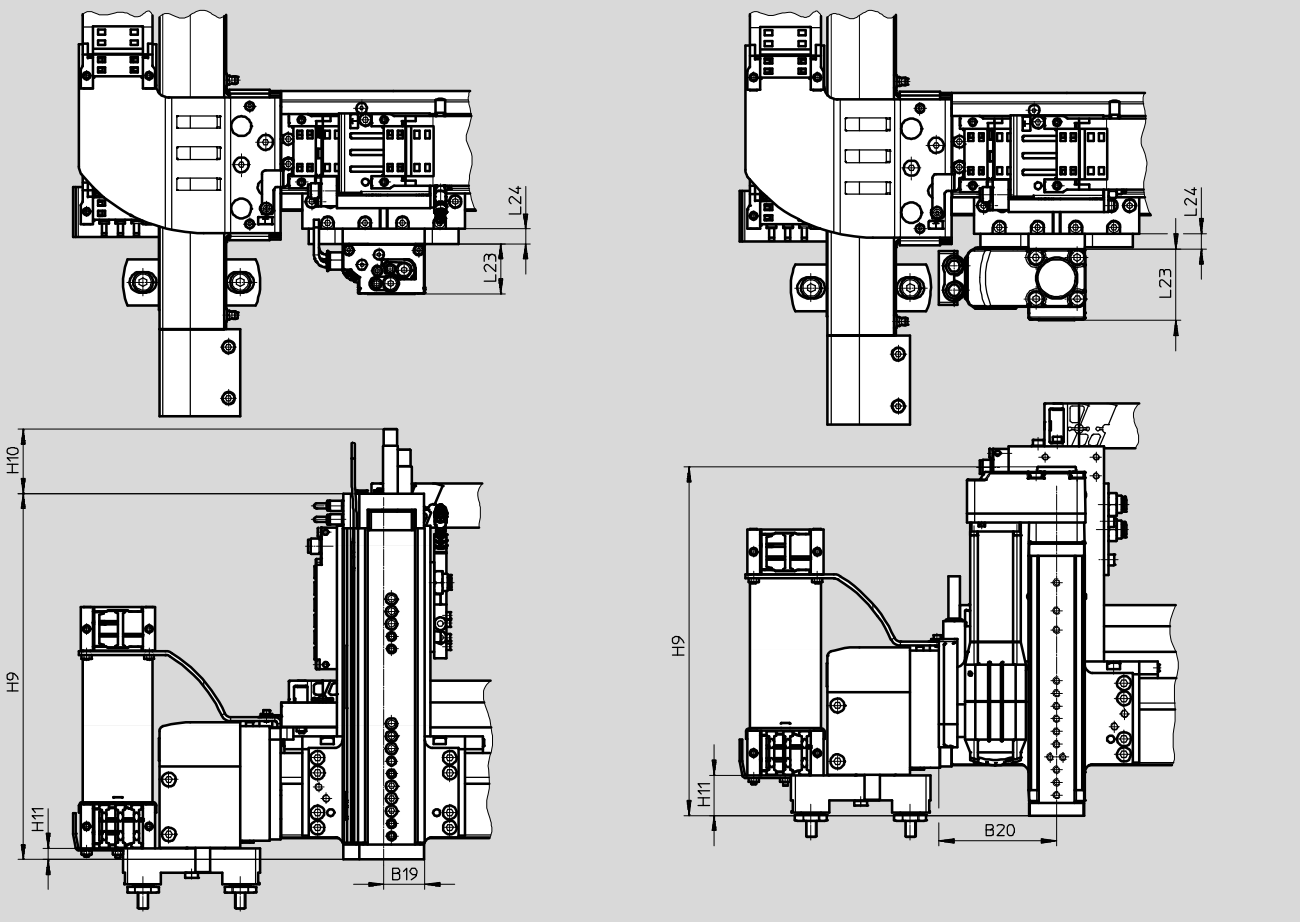

Type	B19	B20	H9	H10 Max.	H11	L23	L24
With pneumatic attachment component (mini slide DGSL)							
EXCH-40-...-P1	33	-	164.6	51.9	9.1	40±0.08	12
EXCH-40-...-P2			243.6				
EXCH-40-...-P3			293.6				
With electric attachment component (mini slide EGSL)							
EXCH-40-...-E1	-	92.3	274	-	31.5	56	12
EXCH-40-...-E2			374				

Planar surface gantries EXCH

Technical data

Dimensions

Download CAD data → www.festo.com

EXCH-60-...-P...

With pneumatic attachment component (mini slide DGSL)

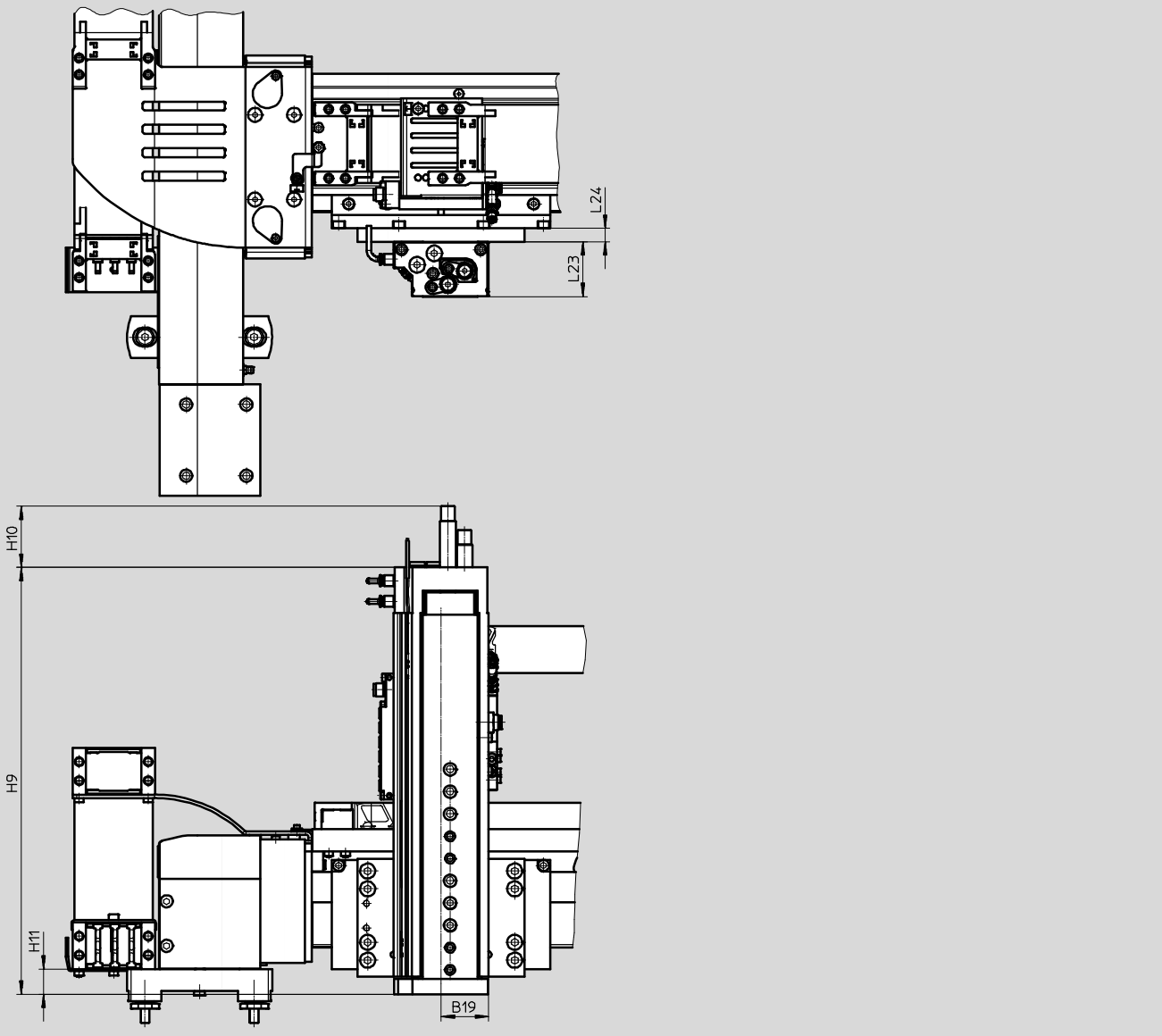

Type	B19	H9	H10 Max.	H11	L23 ±0.08	L24
EXCH-60-...-P1	42.5	183.2	55.5	22.7	49	12
EXCH-60-...-P2		270.2				
EXCH-60-...-P3		333.2				
EXCH-60-...-P4		383.2				

Planar surface gantries EXCH

Technical data

Dimensions

Download CAD data → www.festo.com

EXCH-60-...-E...

With electric attachment component (mini slide EGSL)

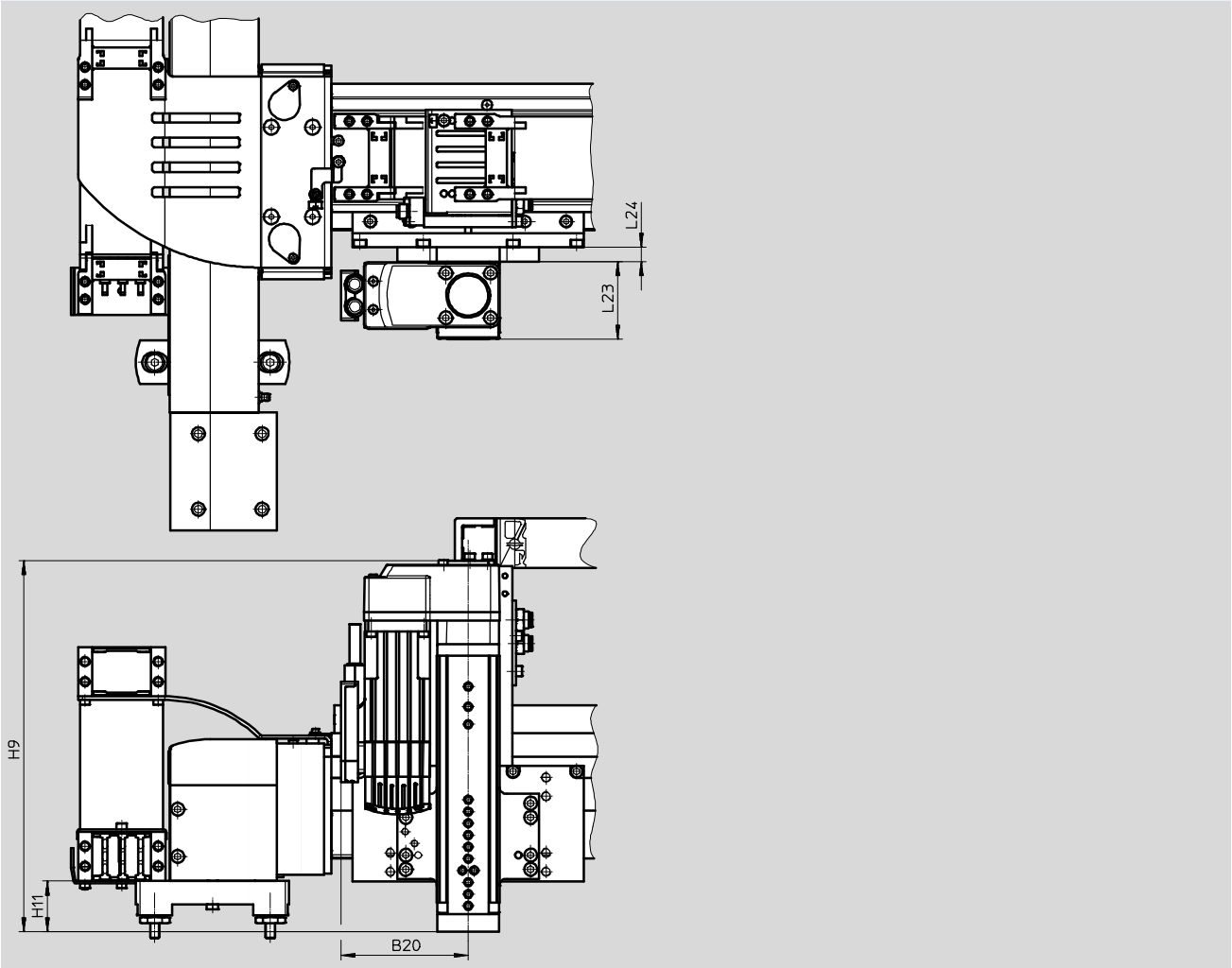

Type	B20	H9	H11	L23	L24
EXCH-60-...-E1	108	315	43	66	12
EXCH-60-...-E2		415			

Planar surface gantries EXCH

Technical data

Dimensions

Download CAD data → www.festo.com

Adjusting kit EADC

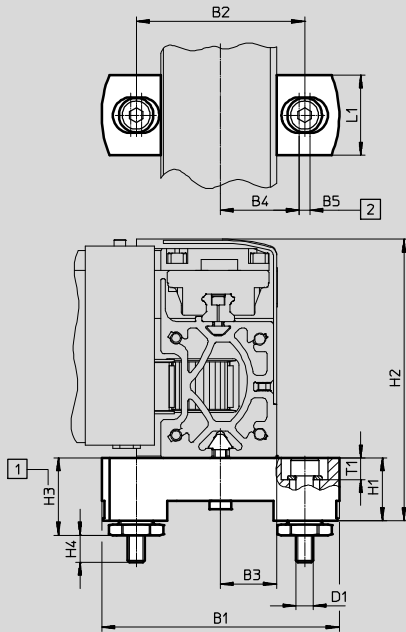

- 1 Adjustable
- 2 Width of hole

Height differences of up to 5 mm can be compensated using the adjusting kit.

Can be ordered via:
Modular product system → 32
Or accessories → 34

For size	B1	B2	B3	B4 ±0.2	B5	D1	H1	H2	H3		H4 Max.	L1	T1
									Min.	Max.			
40	110	78	26	36.5	5	M8	29	129.8	34.8	39.8	14	37	10
60	130	98	36.5	46.5	5	M8	29	149.1	34.8	39.8	14	37	10

Mounting kit

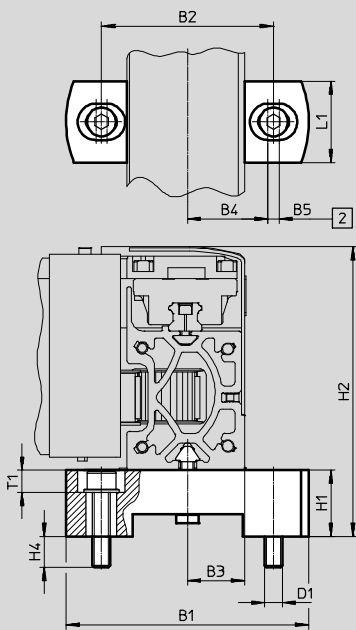

- 2 Width of hole
- No compensation is possible using the mounting kit.

Can be ordered via:
Modular product system → 32
Or accessories → 34

For size	B1	B2	B3	B4 ±0.2	B5	D1	H1 +0.2	H2	H4 Max.	L1	T1
40	110	78	26	36.5	5	M8	30	131.3	14	37	10
60	130	98	36.5	46.5	5	M8	30	150.1	14	37	10

Planar surface gantries EXCH

Technical data

Allocation of planar surface gantry to servo motor for X-/Y-axis	
Planar surface gantry	Motor
EXCH-40-...-AB1	EMMS-AS-70-M-LS-RMB
EXCH-40-...-AS1	EMMS-AS-70-M-LS-RM
EXCH-40-...-AB2 ¹⁾	EMMS-AS-100-S-HS-RMB
EXCH-40-...-AS2	EMMS-AS-100-S-HS-RM
EXCH-60-...-AB2	EMMS-AS-100-M-HS-RMB
EXCH-60-...-AS2	EMMS-AS-100-M-HS-RM
EXCH-60-...-AB3 ¹⁾	EMMS-AS-140-S-HV-RMB
EXCH-60-...-AS3	EMMS-AS-140-S-HV-RM

1) Essential when the planar surface gantry is mounted vertically.

Allocation of planar surface gantry to servo motor for Z-axis	
Planar surface gantry	Motor
EXCH-40-...-E1	EMMS-AS-40-M-LS-TMB
EXCH-40-...-E2	EMMS-AS-40-M-LS-TMB
EXCH-60-...-E1	EMMS-AS-55-M-LS-TMB
EXCH-60-...-E2	EMMS-AS-55-M-LS-TMB

 Note

Third-party motors with a driving torque that is too high can damage the planar surface gantry. When selecting the motors, please observe the limits specified in the technical data. During commissioning, the motor brake must be released for safety purposes. We recommend the teach pendant CDSA (→ modular product system) for this purpose.

Combinations of motor and motor controller			
Planar surface gantry	Order code (→ 32) for		
	Motor type for X-/Y-axis	Attachment component for Z-axis	Motor controller
EXCH-40-...	AB1, AS1	P1, P2, P3	B1, B2
		E1, E2	B2, B3
		None	B1, B2, B3
	AB2, AS2	P1, P2, P3	B6, B7
		E1, E2	B7, B8
		None	B6, B7, B8
EXCH-60-...	AB2, AS2	P1, P2, P3, P4	B6, B7
		E1, E2	B7, B8
		None	B6, B7, B8
	AB3, AS3	P1, P2, P3, P4	B6, B7
		E1, E2	B7, B8
		None	B6, B7, B8

Planar surface gantries EXCH

Ordering data – Modular products

Ordering table					
Size	40	60	Conditions	Code	Entry code
M Module no.	1923050	1939785			
Product type	EXCH series H			EXCH	EXCH
Size	40	60		-...	
Stroke of the X-axis [mm]	200 ... 2000	500 ... 2500			
Stroke of the Y-axis [mm]	200 ... 1000	500 ... 1500			
Guide	Recirculating ball bearing guide			-KF	-KF
Motor type	Servo motor, size 70, with brake	-	1	-AB1	
	Servo motor, size 100, with brake	-	3	-AB2	
	-	Servo motor, size 140, with brake	2 3	-AB3	
	Servo motor, size 70	-	1	-AS1	
	Servo motor, size 100	-		-AS2	
	-	Servo motor, size 140	2	-AS3	
	Without motor	-	4	-W	
Motor attachment position	Bottom			-B	
	Top			-T	
Energy chain connection side	Left-hand			-L	-L
Attachment components	None			-T0	
	Electric lifter, 100 mm stroke			-E1	
	Electric lifter, 200 mm stroke			-E2	
	Pneumatic lifter, 50 mm stroke			-P1	
	Pneumatic lifter, 100 mm stroke			-P2	
	Pneumatic lifter, 150 mm stroke			-P3	
	-	Pneumatic lifter, 200 mm stroke		-P4	

- 1 AB1, AS1** Not in combination with size 60
- 2 AB3, AS3** Not in combination with size 40
- 3 AB2, AB3** Essential in the case of a vertical mounting position
EXCH-40: AB2, EXCH-60: AB3
- 4 W** Not in combination with C, CC, CS, C2, B (operator unit)

 **Note**
In combination with feature W (without motor), the planar surface gantry EXCH is delivered without coupling housing and without coupling.

Transfer order code

EXCH - - - - **KF** - - - **L** -

Planar surface gantries EXCH

Ordering data – Modular product system

Ordering table					
Size	40	60	Conditions	Code	Entry code
[O] Control systems	None			-	
	Mounting plate		[5]	-C	
	Control cabinet		[5]	-CC	
	Control cabinet with base		[5]	-CS	
Multi-axis controller	None			-	
	With CMXR-C2, with integrated PLC			-C2	
Motor controller	None			-	
	2x CMMP-AS-C5-3A, without electric front unit		[6] [8]	-B1	
	2x CMMP-AS-C5-3A, 1x CMMP-AS-C2-3A, for front unit (1 electric axis)		[6]	-B2	
	2x CMMP-AS-C5-3A, 2x CMMP-AS-C2-3A, for front unit (2 electric axes)		[6]	-B3	
	2x CMMP-AS-C5-11A-P3, without electric front unit		[7] [8] [9]	-B6	
	2x CMMP-AS-C5-11A-P3, 1x CMMP-AS-C2-3A, for front unit (1 electric axis)		[7] [9]	-B7	
	2x CMMP-AS-C5-11A-P3, 2x CMMP-AS-C2-3A, for front unit (2 electric axes)		[7] [9]	-B8	
	Safety technology	None			-
Integrated safety switching device				-S1	
Integrated safety switching device with power failure detection			[9]	-S2	
Operator terminal	None			-	
	With teach pendant CDSA		[10]	-B	
Cable length	None			-	
	With cable length 5 m			-5K	
	With cable length 10 m			-10K	
Mounting kit	With adjusting kit			-	
	With mounting kit			-P	
[M] Document language	German			-DE	
	English			-EN	
	Spanish			-ES	
	French			-FR	
	Italian			-IT	
	Russian			-RU	
	Chinese			-ZH	

[5] **C, CC, CS** Mandatory specification in combination with C2, B1, B2, B3, B6, B7, B8, S1, S2, B (teach pendant)

[6] **B1, B2, B3** Only in combination with AB1, AS1

[7] **B6, B7, B8** Not in combination with AB1, AS1

[8] **B1, B6** Not in combination with E1, E2

[9] **B6, B7,**

B8, S2 Essential in the case of a vertical mounting position

[10] **B** Only in combination with C2

Transfer order code

- [] - [] - [] - [] - [] - [] - [] - []

Planar surface gantries EXCH

Accessories

Sensor mounting EAPR

For proximity sensor
SIES-V3B and SIES-Q8B
(for sensing the slide position on the X-axis)

Materials:
Switch lug: Steel
Sensor bracket: Wrought aluminium alloy
RoHS-compliant

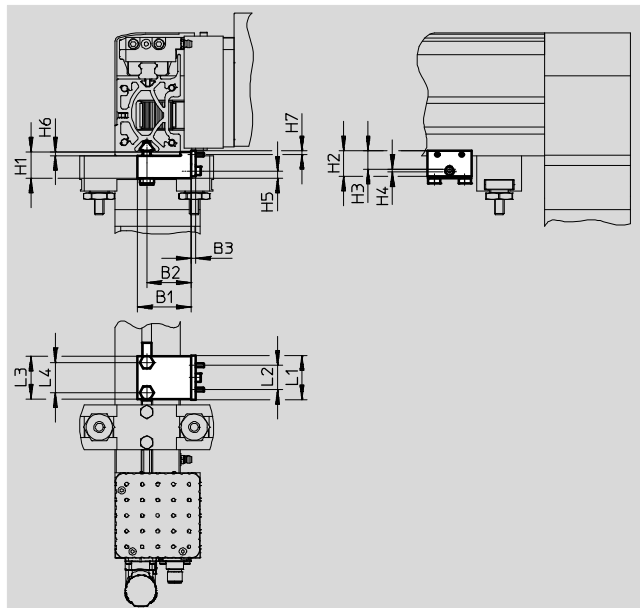

Dimensions and ordering data										
For size	B1	B2	B3	H1	H2	H3 ±0.1	H4	H5	H6 -0.1	H7 -0.2
40	44	36.3	4	21.8	21	15	2.5	6.1	3.1	3
60	54	46.3	4	21	21	15	2.5	5.3	2.3	3

For size	L1	L2	L3	L4	Weight [g]	Part No.	Type
40	36	20	35	25	120	2536353	EAPR-E12-40
60	36	20	35	25	150	2478805	EAPR-E12-60

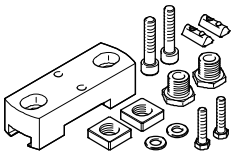
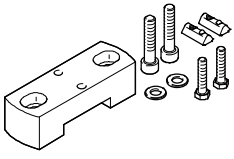
Ordering data				
	For size	Description	Part No.	Type
Adjusting kit EADC				
	40	For mounting and aligning the planar surface gantry. The kit is height-adjustable	8029165	EADC-E12-40
	60		8029166	EADC-E12-60
Mounting kit EAHM				
	40	For mounting the planar surface gantry. The kit is not height-adjustable	3489340	EAHM-E12-K-40
	60		3489318	EAHM-E12-K-60

1) Packaging unit

Planar surface gantries EXCH

Accessories

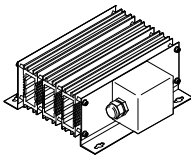
Ordering data					
	For size	Description	Part No.	Type	
Braking resistor CACR					
	40, 60	Essential in the case of a vertical mounting position	2882343	CACR-KL2-40-W2000	

1) Packaging unit

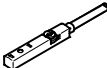
Permissible proximity sensor for sensing the position of the slide on the Y-axis					
Ordering data – Proximity sensor for T-slot, inductive					Technical data → Internet: sies
	Type of mounting	Electrical connection	Switching output	Cable length [m]	Part No. Type
	Inserted in the slot from above, flush with the cylinder profile	Plug connector M8x1, 3-pin	PNP, N/O contact	0.3	551387 SIES-8M-PS-24V-K-0,3-M8D

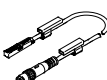
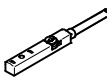
Permissible proximity sensors for sensing the positions on the Z-axis					
Ordering data – Proximity sensors for T-slot					Technical data → Internet: smt
	Type of mounting	Electrical connection	Switching output	Cable length [m]	Part No. Type
With mini slide DGSL (magneto-resistive)					
	Inserted in the slot from above, flush with the cylinder profile	Plug connector M8x1, 3-pin	PNP, N/O contact	0.3	551367 SME-10M-DS-24V-E-0,3-L-M8D
With mini slide EGSL (inductive)					
	Inserted in the slot from above, flush with the cylinder profile	Plug connector M8x1, 3-pin	PNP, N/O contact	0.3	551387 SIES-8M-PS-24V-K-0,3-M8D

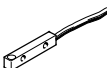
Permissible proximity sensors in combination with sensor mounting EAPR-E12					
Ordering data – Proximity sensors					Technical data → Internet: sies
	Type of mounting	Electrical connection	Switching output	Part No.	Type
N/O contact					
	Screwed on	Plug connector M8x1, 3-pin	PNP	150491	SIES-V3B-PS-S-L
N/C contact					
	Screwed on	Cable, 3-wire	NPN	174550	SIES-Q8B-NO-K-L

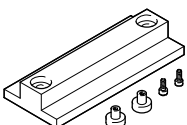
Ordering data					
	For size	Description	Part No.	Type	
Adjusting tool EADT					
	40, 60	For aligning and checking the levelness of the planar surface gantry	3197697	EADT-W-E12	

Product Range and Company Overview

A Complete Suite and Company Overview

Our experienced engineers provide complete support at every stage of your development process, including: conceptualization, analysis, engineering, design, assembly, documentation, validation, and production.



Custom Automation Components
Complete custom engineered solutions



Custom Control Cabinets
Comprehensive engineering support and on-site services



Complete Systems
Shipment, stocking and storage services

The Broadest Range of Automation Components

With a comprehensive line of more than 30,000 automation components, Festo is capable of solving the most complex automation requirements.



Electromechanical
Electromechanical actuators, motors, controllers & drivers



Pneumatics
Pneumatic linear and rotary actuators, valves, and air supply



PLCs and I/O Devices
PLC's, operator interfaces, sensors and I/O devices

Supporting Advanced Automation... As No One Else Can!

Festo is a leading global manufacturer of pneumatic and electromechanical systems, components and controls for industrial automation, with more than 16,000 employees in 60 national headquarters serving more than 180 countries. For more than 80 years, Festo has continuously elevated the state of manufacturing with innovations and optimized motion control solutions that deliver higher performing, more profitable automated manufacturing and processing equipment. Our dedication to the advancement of automation extends beyond technology to the education and development of current and future automation and robotics designers with simulation tools, teaching programs, and on-site services.

Quality Assurance, ISO 9001 and ISO 14001 Certifications

Festo Corporation is committed to supply all Festo products and services that will meet or exceed our customers' requirements in product quality, delivery, customer service and satisfaction.

To meet this commitment, we strive to ensure a consistent, integrated, and systematic approach to management that will meet or exceed the requirements of the ISO 9001 standard for Quality Management and the ISO 14001 standard for Environmental Management.



© Copyright 2013, Festo Corporation. While every effort is made to ensure that all dimensions and specifications are correct, Festo cannot guarantee that publications are completely free of any error, in particular typing or printing errors. Accordingly, Festo cannot be held responsible for the same. For Liability and Warranty conditions, refer to our "Terms and Conditions of Sale", available from your local Festo office. All rights reserved. No part of this publication may be reproduced, distributed, or transmitted in any form or by any means, electronic, mechanical, photocopying or otherwise, without the prior written permission of Festo. All technical data subject to change according to technical update.



Printed on recycled paper at New Horizon Graphic, Inc., FSC certified as an environmental friendly printing plant.

Festo North America

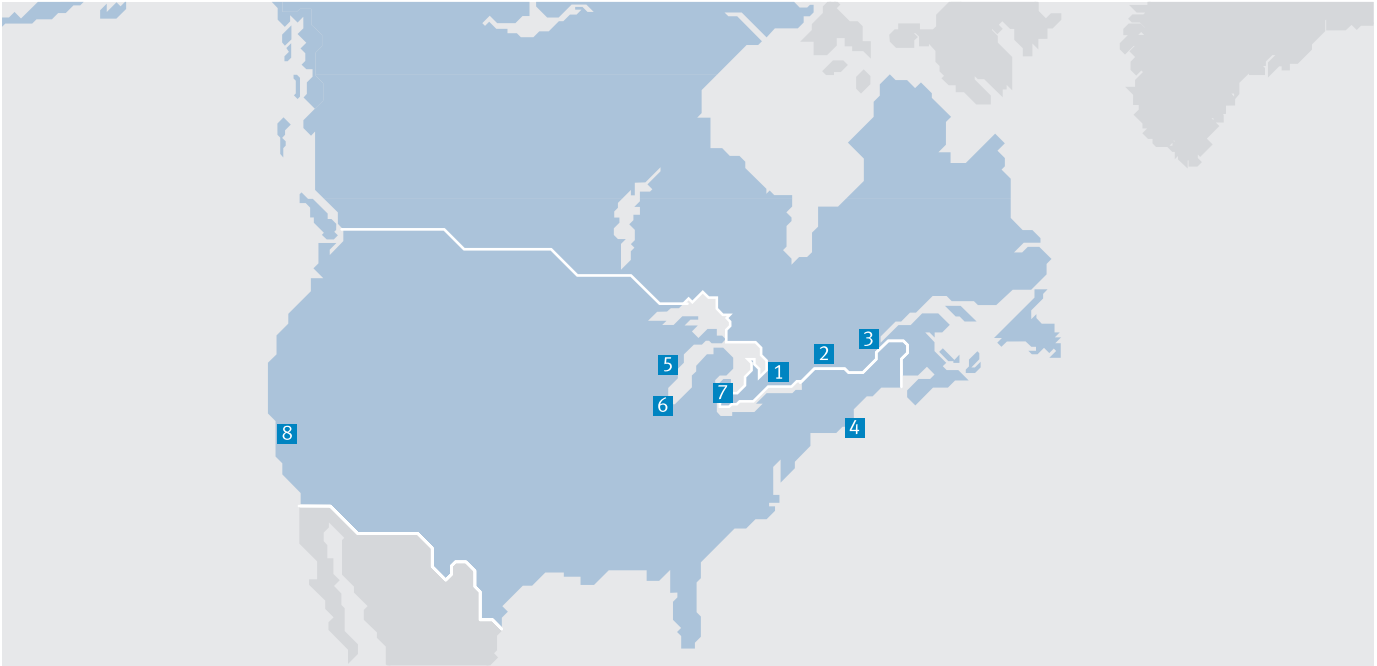

**1 Festo Canada
Headquarters
Festo Inc.**
5300 Explorer Drive
Mississauga, ON
L4W 5G4

2 Montréal
5600, Trans-Canada
Pointe-Claire, QC
H9R 1B6

3 Québec City
2930, rue Watt#117
Québec, QC
G1X 4G3



**4 Festo United States
Headquarters
Festo Corporation**
395 Moreland Road
Hauppauge, NY
11788

5 Appleton
North 922 Tower View Drive, Suite N
Greenville, WI
54942

7 Detroit
1441 West Long Lake Road
Troy, MI
48098

6 Chicago
85 W Algonquin - Suite 340
Arlington Heights, IL
60005

8 Silicon Valley
4935 Southfront Road, Suite F
Livermore, CA
94550

Festo Regional Contact Center

Canadian Customers

Commercial Support:
Tel: 1 877 GO FESTO (1 877 463 3786)
Fax: 1 877 FX FESTO (1 877 393 3786)
Email: festo.canada@ca.festo.com

Technical Support:

Tel: 1 866 GO FESTO (1 866 463 3786)
Fax: 1 877 FX FESTO (1 877 393 3786)
Email: technical.support@ca.festo.com

USA Customers

Commercial Support:
Tel: 1 800 99 FESTO (1 800 993 3786)
Fax: 1 800 96 FESTO (1 800 963 3786)
Email: customer.service@us.festo.com

Technical Support:

Tel: 1 866 GO FESTO (1 866 463 3786)
Fax: 1 800 96 FESTO (1 800 963 3786)
Email: product.support@us.festo.com