

Rotary drives ERMO, electric



Rotary drives ERMO, electric

Key features

At a glance

General

- Electric rotary drive with stepper motor and integrated gear unit
- ServoLite – closed-loop operation with encoder
- Heavy-duty bearing for high forces and torques
- Backlash-free pre-stressed rotating plate with very good axial eccentricity and concentricity properties

Range of applications

- Optional holding brake
- Hollow shaft for energy throughfeed for attachments
- Quick and accurate installation
- Rotating and positioning parts
- Simple rotary indexing table applications
- As a rotary axis in multi-axis applications

The technology in detail

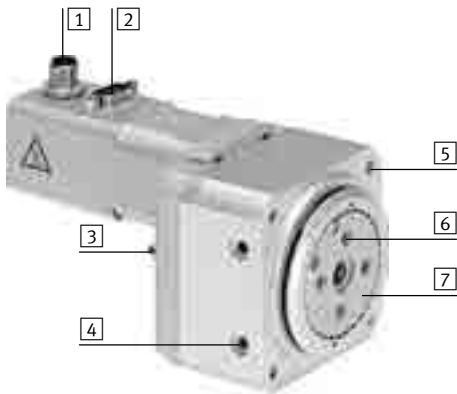

- 1 Encoder connection
- 2 Motor connection
- 3 Proximity sensor for homing or position sensing
- 4 Thread/centring holes for mounting
- 5 Thread for mounting
- 6 Thread/centring holes for attachments
- 7 Rotating plate

Optimised Motion Series (OMS) – Package solution with motor and motor controller

A package that makes positioning easier than ever before. The Optimised Motion Series is as easy to handle as a pneumatic cylinder, but with the functionality of an electric drive.



Simple choice

- Easy sizing and selection using cycle time charts
- No specialist knowledge of electric drive technology required

Ordering and logistics

- All the necessary component parts with a single part number
- Motors mounted on rotary drive

Quick to configure

- Parameterisation and commissioning via web server/browser
- Parameterise up to 7 freely definable positions directly on the PC



For simple positioning tasks

Rotary drive ERMO



Controller CMMO

→ Internet: cmmo



Rotary drives ERMO, electric

Key features

Mounting options

At the side

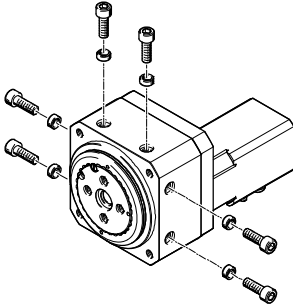

From the front/rear

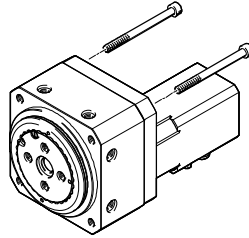

Motor attachment variants

Top (standard)

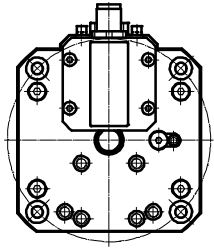

Left (feature L)

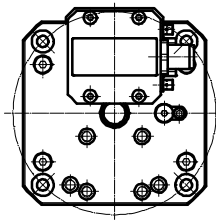

Right (feature R)

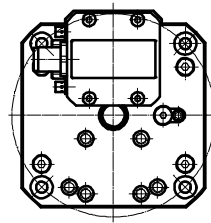

Direct mounting options with drives from Festo

With electric cylinder EPCO

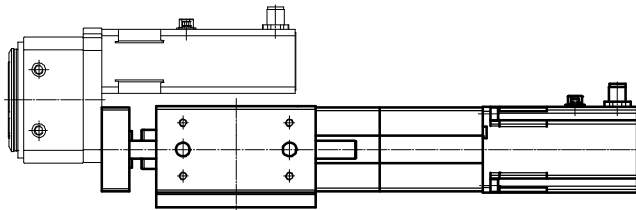

Size	Base axis		
	EPCO-16-...-KF	EPCO-25-...-KF	EPCO-40-...-KF
Assembly axis			
ERMO-12	■	-	-
ERMO-16	-	■	-
ERMO-25	-	-	■

With mini slide EGSL

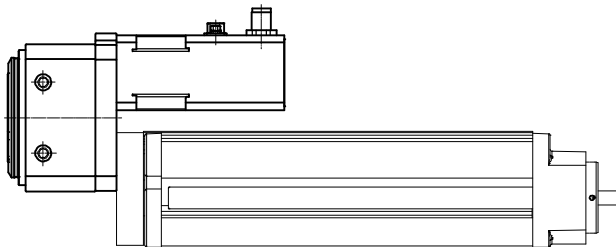

Size	Base axis		
	EGSL-35	EGSL-45	EGSL-55
Assembly axis			
ERMO-12	■	-	-
ERMO-16	-	■	-
ERMO-25	-	-	■
ERMO-32	-	-	■

Rotary drives ERMO, electric

Type codes

		ERMO	-	16	-	ST	-	E	B	-		+	5E	+	C5		DIO		P
Type																			
ERMO	Rotary drive																		
Size																			
Motor type																			
ST	Stepper motor																		
Measuring unit																			
E	Encoder																		
Brake																			
-	None																		
B	With brake																		
Cable outlet direction																			
-	Top (standard)																		
L	Left																		
R	Right																		
Connecting cable to motor controller																			
-	None																		
1.5E	1.5 m, straight plug connector																		
2.5E	2.5 m, straight plug connector																		
5E	5 m, straight plug connector																		
7E	7 m, straight plug connector																		
10E	10 m, straight plug connector																		
1.5EA	1.5 m, angled plug connector																		
2.5EA	2.5 m, angled plug connector																		
5EA	5 m, angled plug connector																		
7EA	7 m, angled plug connector																		
10EA	10 m, angled plug connector																		
Controllertype																			
C5	CMMO, 5 A																		
Bus protocol/activation																			
-	None																		
DIO	Digital I/O interface																		
LK	IO-Link																		
Switching input/output																			
-	None																		
N	NPN																		
P	PNP																		

Rotary drives ERMO, electric

Peripherals overview

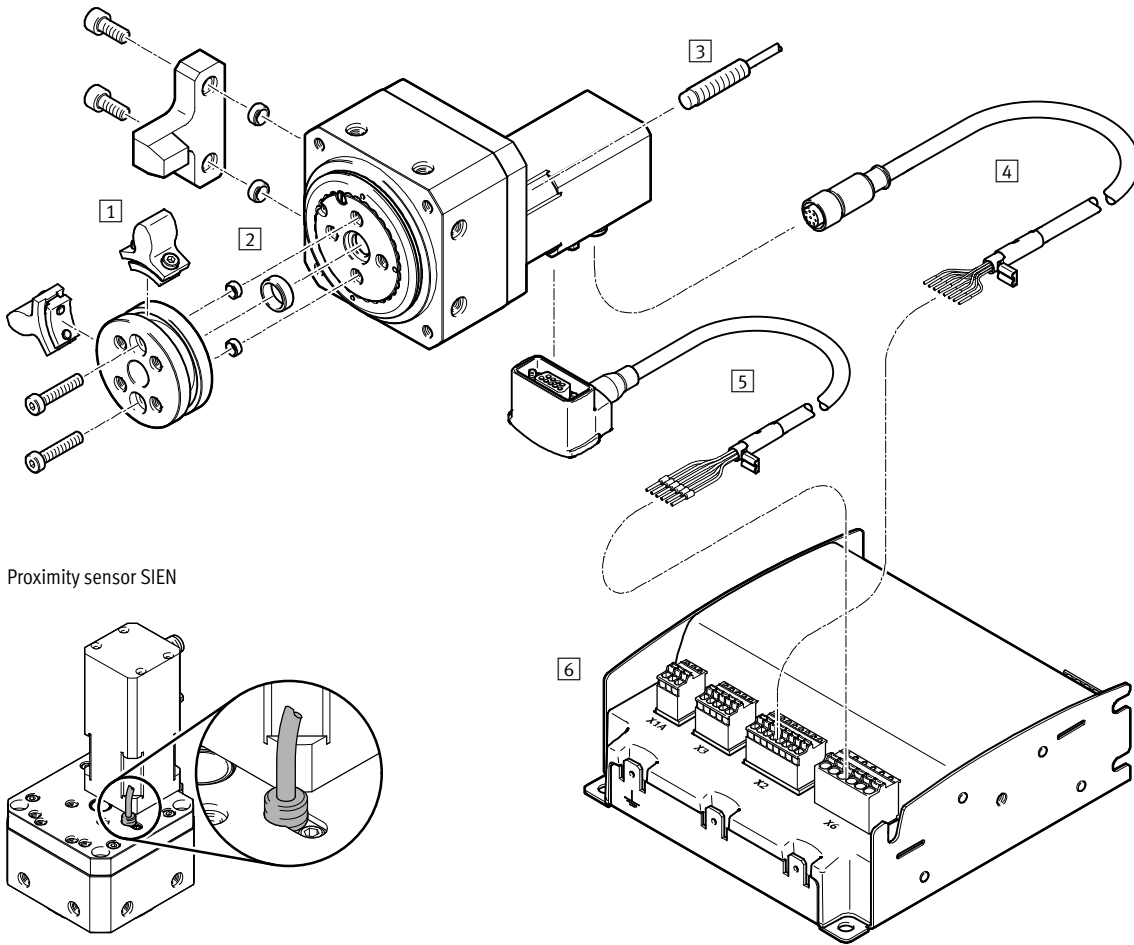

Proximity sensor SIEN

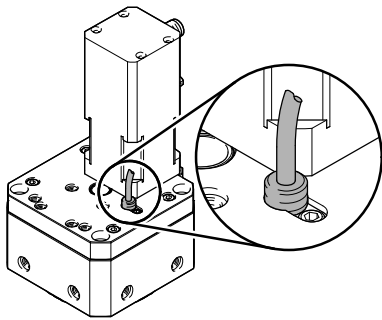

Accessories		
Type/order code	Description	→ Page/Internet
1 Stop kit EADP	<ul style="list-style-type: none"> • For homing to the end position • As end stop for rotary drives with no brake • For safety functions 	18
2 Centring sleeve ZBH	<ul style="list-style-type: none"> • For centring attachments • For centring the rotary drive 	19
3 Proximity sensor SIEN	For homing or position sensing	19
4 Encoder cable NEBM	For connecting the encoder and controller	20
5 Motor cable NEBM	For connecting the motor and controller	20
6 Motor controller CMMO	For positioning the rotary drive	20

Rotary drives ERMO, electric

Technical data

 Size

12, 16, 25, 32



General technical data					
Size	12	16	25	32	
Design	Electromechanical rotary drive with integrated gear unit				
Angle of rotation	Infinite				
Repetition accuracy ¹⁾	[°]	±0.05	±0.05	±0.05	±0.1
Torsional backlash ¹⁾	[°]	0.2			
Positioning time	→ 8				
Gear ratio	9:1			7:1	
Step angle with full step	[°]	1.8 ±5%			
Type of mounting	Via internal thread				
Mounting position	Any				
Product weight					
Without brake	[g]	475	900	1350	2200
With brake	[g]	–	960	1500	2380

1) Without payload in new condition

Mechanical data					
Size	12	16	25	32	
Nominal torque ¹⁾	[Nm]	0.15	0.8	2.5	5
Holding torque	[Nm]	0.33	0.81	4	7
Nominal rotational speed	[rpm]	100	100	66	50
Max. speed	[rpm]	200	200	150	100
Permissible mass moment of inertia	[kgm ² x10 ⁻⁴]	3	13	65	164
Mass moment of inertia J _o	[kgm ² x10 ⁻⁴]	0.0079	0.0383	0.114	0.39
Max. impact energy	[Jx10 ⁻⁴]	0.2	0.7	1.6	2.9

1) Theoretical torque at nominal rotary speed → 8

Rotary drives ERMO, electric

Technical data

Electrical data					
Size		12	16	25	32
Motor					
Nominal operating voltage	[V DC]	24			
Nominal current	[A]	0.8	1.4	3	4.2
Duty cycle	[%]	100			
Brake					
Nominal voltage	[V DC]	-		24	
Rated output	[W]	-		8	
Holding torque	[Nm]	-		1	2.5
Mass moment of inertia	[kgm ² x10 ⁻⁴]	-		0.69	1.3
Encoder					
Rotary position encoder		Incremental			
Rotary position encoder measuring principle		Opto-electrical			
Pulses/revolution	[1/rev]	500			
Interface		RS422, TTL, AB channel + zero index			
Operating voltage	[V DC]	5			
Insulation protection class		B (130 °C)			

Operating and environmental conditions		
Ambient temperature	[°C]	0 ... +50
Storage temperature	[°C]	-20 ... +60
Degree of protection		IP40
Relative air humidity	[%]	0 ... 85 (non-condensing)
Corrosion resistance class CRC ¹⁾		1
CE marking (see declaration of conformity)		To EU EMC Directive ²⁾
Approval certificate		RCM trademark

- 1) Corrosion resistance class CRC 1 to Festo standard FN 940070
Low corrosion stress. For dry indoor applications or transport and storage protection. Also applies to parts behind covers, in the non-visible interior area, and parts which are covered in the application (e.g. drive trunnions).
- 2) For information about the applicability of the component see the manufacturer's EC declaration of conformity at: www.festo.com/sp → User documentation.
If the component is subject to restrictions on usage in residential, office or commercial environments or small businesses, further measures to reduce the emitted interference may be necessary.

Materials

Sectional view

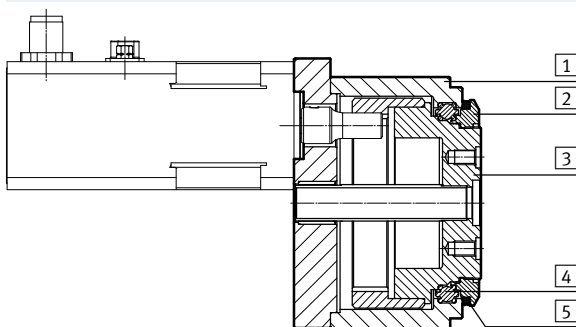

Rotary drive		
1	Housing	Anodised wrought aluminium alloy
2	Clamping ring	Anodised wrought aluminium alloy
3	Rotating plate	Anodised wrought aluminium alloy
4	Ball bearing	Rolled steel
5	Sealing ring	NBR
Note on materials		RoHS compliant
		Contains paint-wetting impairment substances

Rotary drives ERMO, electric

Technical data

Torque M as a function of speed n

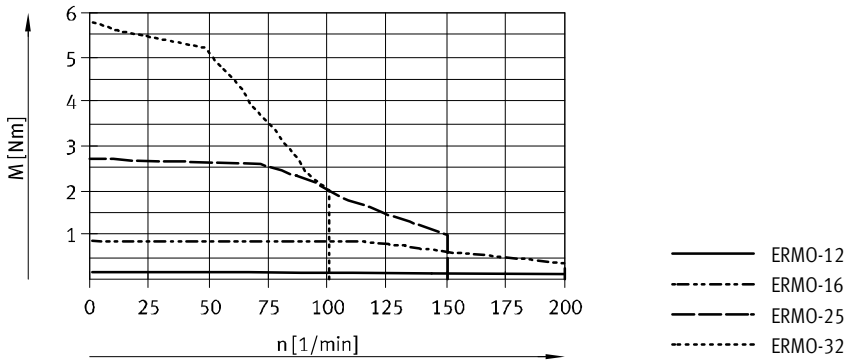

Positioning time t as a function of angle of rotation α

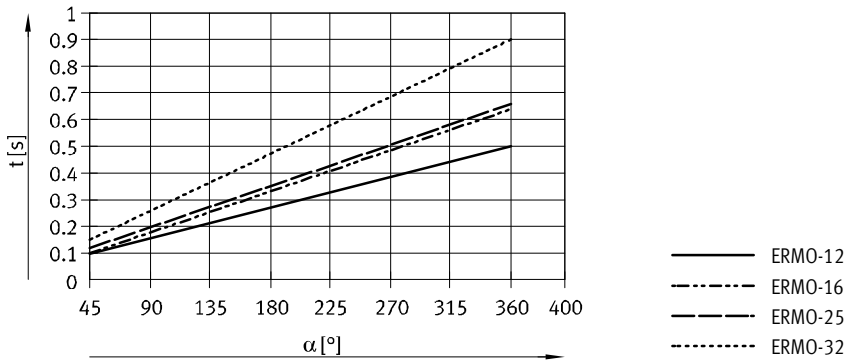

Axial eccentricity and concentricity

Axial eccentricity

Measured on the surface of the rotating plate at the plate edge, in new condition.

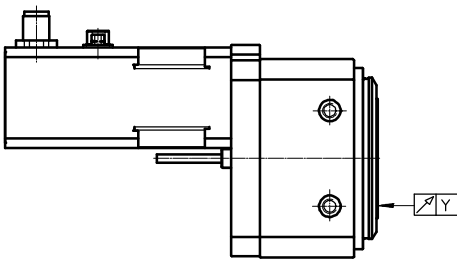

Concentricity

Measured at the centring hole of the rotating plate, in new condition.

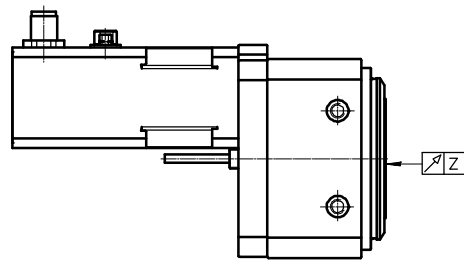

Size		12	16	25	32
Axial eccentricity Y	[mm]	<0.02	<0.02	<0.02	<0.04
Concentricity Z	[mm]	<0.02	<0.02	<0.02	<0.04

Rotary drives ERMO, electric

Technical data

Max. permissible axial and radial force F_x/F_z					
Size		12	16	25	32
Static					
Axial force F_x	[N]	500	600	700	800
Radial force F_z	[N]	500	750	1200	2000
Dynamic					
Axial force F_x	[N]	180	290	350	450
Radial force F_z	[N]	200	300	450	550

Max. dynamic axial force F_x as a function of lever arm l

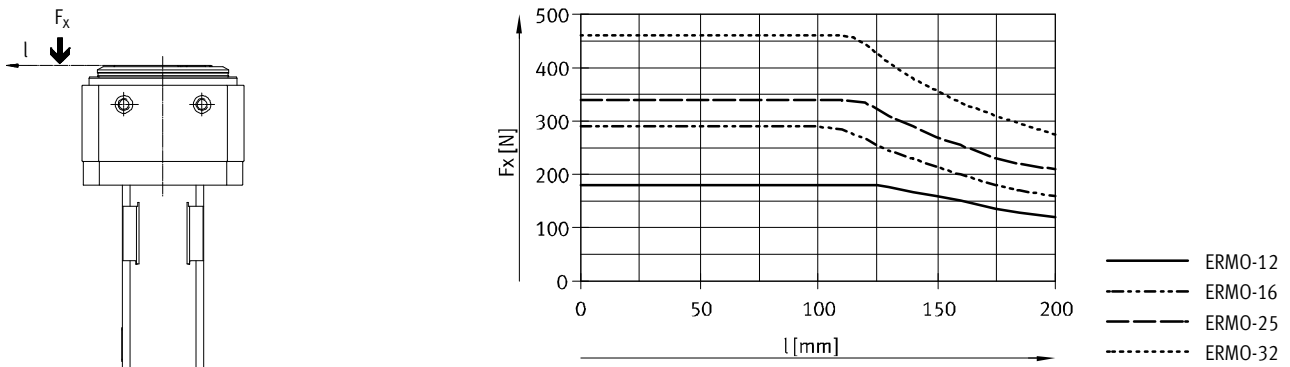

Max. dynamic radial force F_z as a function of lever arm l

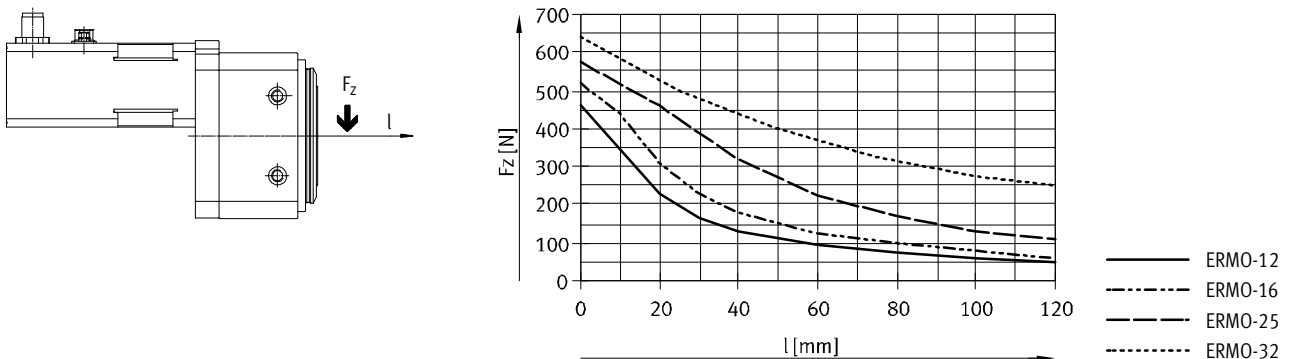

Pin allocation

Motor

ERMO-12/-16

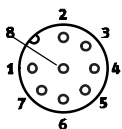

ERMO-25/-32

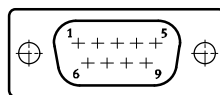

Encoder

ERMO-12/-16/-25/-32

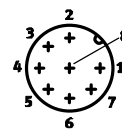

PIN	Function
1	String A
2	String A/
3	String B
4	String B/
5	n.c.
6	n.c.
7	Brake +24 V DC ¹⁾
8	Brake GND ¹⁾
-	-

PIN	Function
1	String A
2	String A/
3	String B
4	String B/
5	n.c.
6	n.c.
7	Brake +24 V DC ¹⁾
8	Brake GND ¹⁾
9	n.c.

PIN	Function
1	Signal trace A
2	Signal trace A/
3	Signal trace B
4	Signal trace B/
5	GND encoder
6	Signal trace N
7	Signal trace N/
8	VCC auxiliary supply +5 V
GND	Shield on plug housing

1) Only on motors with brake.

Rotary drives ERMO, electric

Technical data

Dimensions

Download CAD data → www.festo.com

Size 12

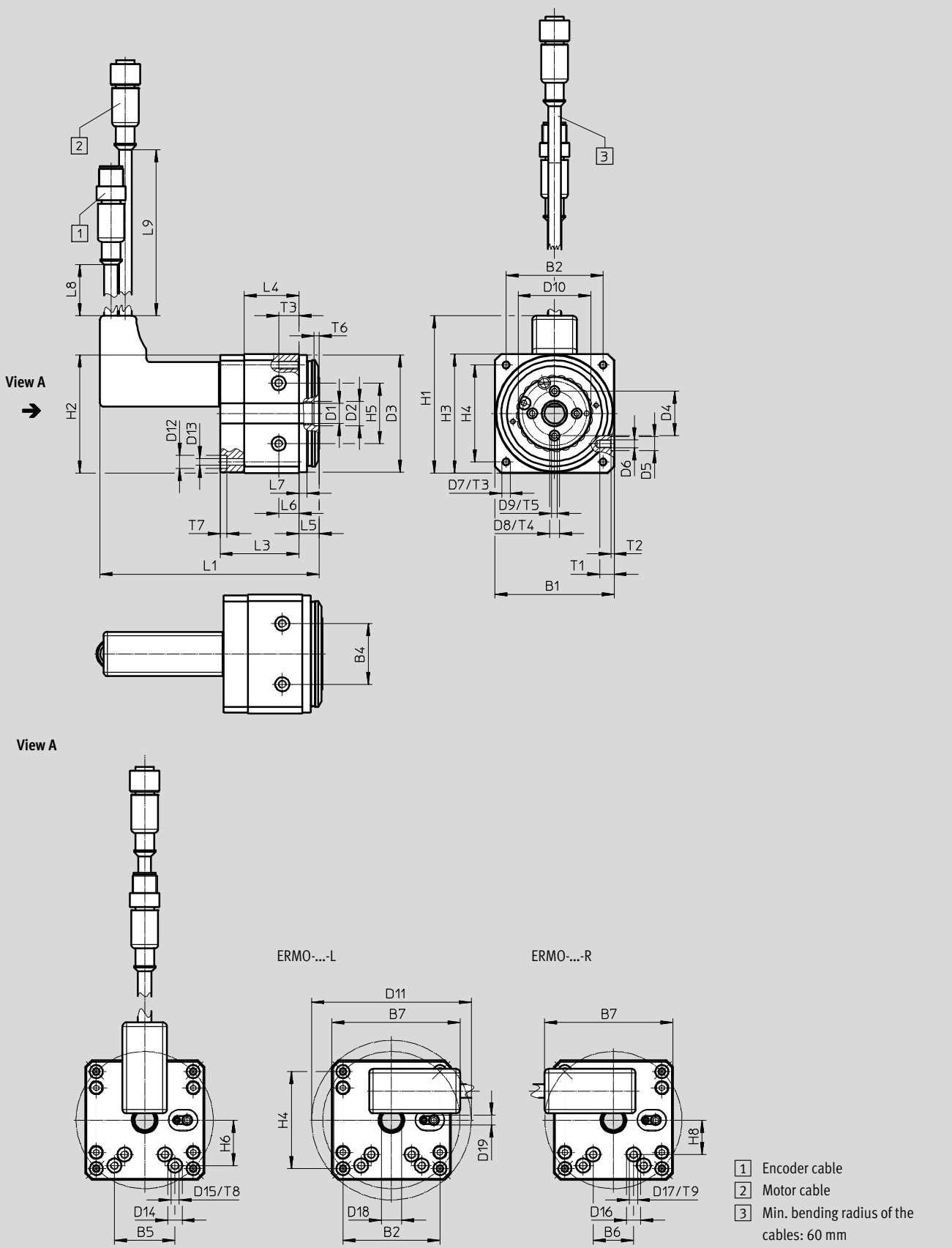

Rotary drives ERMO, electric

Technical data

Size	B1	B2	B4	B5	B6	B7	D1	D2	D3	D4
	±0.3		±0.03	±0.02	±0.02		∅	∅ H8	∅ f8	∅ ±0.02
12	59	48	30	30	20	46	10	12	58	22

Size	D5	D6	D7	D8	D9	D10	D11	D12	D13	D14
	∅ H7			∅ H7		∅	∅ ±0.5	∅	∅	∅ H7
12	7	M4	M4	5	M3	36	79	6.5	3.4	7

Size	D15	D16	D17	D18	D19	H1	H2	H3	H4	H5
		∅ H7		max.				±0.3		±0.03
12	M4	7	M4	7	M5x0.5	80	58.5	59	48	30

Size	H6	H8	L1	L3	L4	L5	L6	L7	L8	L9
			±1.5	±0.6		±0.2	±0.1	±0.1		
12	22.5	17	100	39	27	10	10	4	300	300

Size	T1	T2	T3	T4	T5	T6	T7	T8	T9
		+0.1		+0.1		+0.1			
12	7	1.5	10	1.2	7	2.5	3.4	1.5	1.5

Rotary drives ERMO, electric

Technical data

Dimensions

Download CAD data → www.festo.com

Size 16

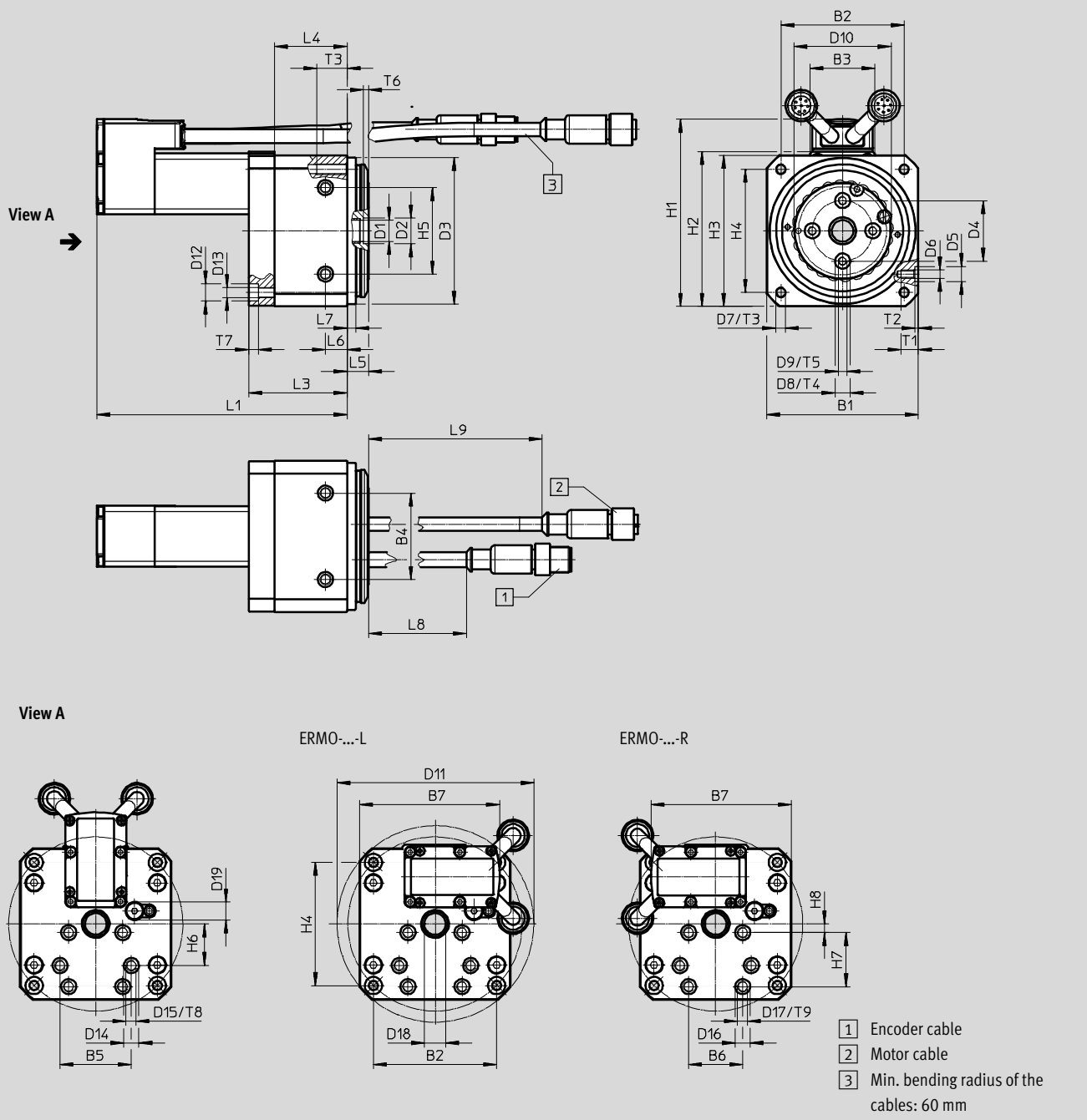

Rotary drives ERMO, electric

Technical data

Size	B1	B2	B3	B4	B5	B6	B7	D1 ∅	D2 ∅ H8	D3 ∅ f8	D4 ∅ ±0.02
16	±0.3			±0.03	±0.02	±0.02		10	12	68	28

Size	D5 ∅ H7	D6	D7	D8 ∅ H7	D9	D10 ∅	D11 ∅ ±0.5	D12 ∅	D13 ∅	D14 ∅ H7
16	7	M5	M5	7	M4	45	91	8	4.6	7

Size	D15	D16 ∅ H7	D17	D18 max.	D19	H1	H2	H3 ±0.3	H4	H5 ±0.03
16	M5	7	M5	–	M8x1	87	71.8	70	57	40

Size	H6	H7 ±0.02	H8	L1 ±1.5	L3 ±0.6	L4	L5 ±0.2	L6 ±0.1	L7 ±0.1	L8
16	19.3	25	4	116/142 ¹⁾	45.5	33.5	10	10	4	250

Size	L9	T1	T2 +0.1	T3	T4 +0.1	T5	T6 +0.1	T7	T8	T9
16	350	8	1.5	14	1.5	8	2.5	4.5	1.5	1.5

1) Motor with brake

Rotary drives ERMO, electric

FESTO

Technical data

Size	B1 ±0.3	B2	B3	B4 ±0.03	B5 ±0.02	B6 ±0.02	B7	D1 ∅	D2 ∅ H8	D3 ∅ f8	D4 ∅ ±0.02
25	83	65	44	40	40	25	78	10	15	76	30
32	105	85	58	60	-	25	96	16	20	96	42

Size	D5 ∅ H7	D6	D7	D8 ∅ H7	D9	D10 ∅	D11 ∅ ±0.5	D12 ∅	D13 ∅	D14 ∅ H7
25	9	M6	M6	7	M5	50	106	10	5.5	7
32	12	M 8	M 8	7	M5	65	135	11	6.6	-

Size	D15	D16 ∅ H7	D17	D18 max.	D19	H1	H2	H3 ±0.3	H4	H5 ±0.03
25	M5	7	M5	10	M8x1	103	89	83	65	40
32	-	7	M5	9	M8x1	125	110.5	105	85	60

Size	H6	H7 ±0.02	H8	L1 ±1.5	L3 ±0.6	L4	L5 ±0.2	L6 ±0.1	L7 ±0.1
25	32.5	25	10.5	146/179 ¹⁾	51.3	39.3	10	10	4
32	-	25	15	148/189 ¹⁾	46.5	34.5	12	10	6

Size	T1	T2 +0.1	T3	T4 +0.1	T5	T6 +0.1	T7	T8	T9
25	9.5	2	16	1.5	8.5	2.5	5.5	1.5	1.5
32	15	2.5	20	1.5	10	2.8	6.8	-	1.5

1) Motor with brake

Rotary drives ERMO, electric

Technical data

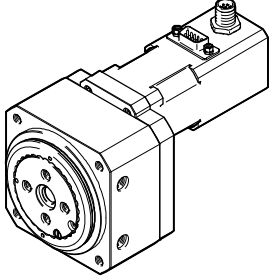
Ordering data			
	Size	Part No.	Type
	12	3008525	ERMO-12-ST-E
	16	3008526	ERMO-16-ST-E
	25	3008527	ERMO-25-ST-E
	32	3008528	ERMO-32-ST-E

Rotary drives ERMO, electric

Ordering data – Modular products



Ordering table							
Size	12	16	25	32	Condi- tions	Code	Entry code
M Module no.	2954695	2954696	2954697	2954698			
Function	Electric cylinders					ERMO	ERMO
Size	12	16	25	32		-...	
Motor type	Stepper motor					-ST	-ST
Measuring unit	Encoder					-E	-E
O Brake	None		With brake			B	
Cable outlet direction	Top (standard)						
	Left					-L	
	Right					-R	
Connecting cable to motor controller	Without						
	1.5 m, straight plug connector					+1.5E	
	2.5 m, straight plug connector					+2.5E	
	5 m, straight plug connector					+5E	
	7 m, straight plug connector					+7E	
	10 m, straight plug connector					+10E	
			1.5 m, angled plug connector			+1.5EA	
			2.5 m, angled plug connector			+2.5EA	
			5 m, angled plug connector			+5EA	
			7 m, angled plug connector			+7EA	
		10 m, angled plug connector			+10EA		
Controller type	None						
	CMMO, 5 A				1	+C5	
Bus protocol/activation	None						
	Digital I/O interface					DIO	
	IO-Link					LK	
Switching input/output	None						
	NPN				2	N	
	PNP					P	

1 **DIO, LK, N, P** Must be selected if controller type +C5 is selected.

2 **N** Not with IO-Link LK

M Mandatory data

O Options

Transfer order code

ERMO - - **ST** - **E** - + +

Rotary drives ERMO, electric

Accessories

Stop kit EADP

Materials:

Housing: Anodised aluminium

Stops: Nickel-plated beryllium bronze

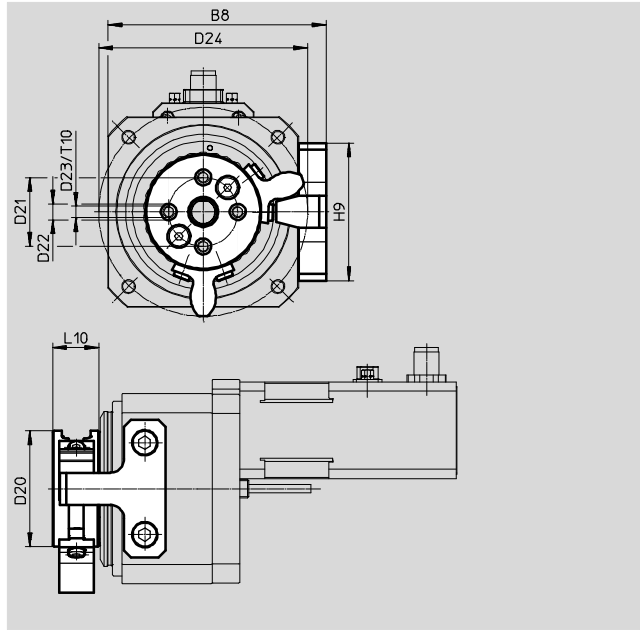
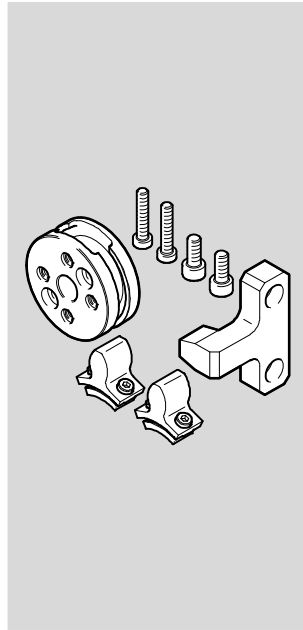



Dimensions and ordering data									
For size	B8	D20 Ø ±0.1	D21 Ø ±0.1	D22 Ø H7	D23	D24 Ø	H9	L10 ±0.1	T10
12	69	44	28	7	M4	74.8	40	16	16
16	80	44	28	7	M4	74.2	52	16	16
25	95	50.5	30	7	M5	91	60	20	20
32	120	64	42	7	M5	90	80	27	27

For size	Setting range for rotation angle		Weight [g]	Part No.	Type
	1 stop	2 stops			
12	0 ... 325	0 ... 280	96	3044562	EADP-ES-R3-12
16	0 ... 325	0 ... 280	100	2715501	EADP-ES-R3-16
25	0 ... 325	0 ... 270	210	2721599	EADP-ES-R3-25
32	0 ... 325	0 ... 270	290	2735411	EADP-ES-R3-32



Rotary drives ERMO, electric



Accessories

FESTO

Ordering data – Centring sleeves			Technical data → Internet: zbh		
	For size	Description	Part No.	Type	PU ¹⁾
	12, 16	For centring the drive for lateral mounting	186717	ZBH-7	10
	25		150927	ZBH-9	
	32		189653	ZBH-12	
	12 ... 32	For centring attachments on the rotating plate	186717	ZBH-7	
	12, 16	For centring attachments in the middle of the rotating plate	189653	ZBH-12	
	25		191409	ZBH-15	
	32		150901	SLZZ-25/16	1

1) Packaging unit

Ordering data – Proximity sensor M5/M8 (round design), inductive						Technical data → Internet: sien	
	Switching element function	Electrical connection	LED	Switching output	Cable length [m]	Part No.	Type
For size 12							
	N/C contact	Cable, 3-wire	■	PNP	2.5	150374	SIEN-M5B-PO-K-L
		Plug connector M8x1, 3-pin			–	150375	SIEN-M5B-PO-S-L
For size 16 ... 32							
	N/C contact	Cable, 3-wire	■	PNP	2.5	150390	SIEN-M8B-PO-K-L
		Plug connector M8x1, 3-pin			–	150391	SIEN-M8B-PO-S-L

Ordering data – Connecting cables				Technical data → Internet: nebu	
	Electrical connection, left	Electrical connection, right	Cable length [m]	Part No.	Type
	Straight socket, M8x1, 3-pin	Cable, open end, 3-wire	2.5	159420	SIM-M8-3GD-2,5-PU
			2.5	541333	NEBU-M8G3-K-2.5-LE3
			5.0	541334	NEBU-M8G3-K-5-LE3
	Angled socket, M8x1, 3-pin	Cable, open end, 3-wire	2.5	541338	NEBU-M8W3-K-2.5-LE3
			5.0	541341	NEBU-M8W3-K-5-LE3

Rotary drives ERMO, electric

Accessories

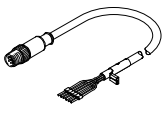
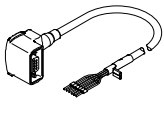
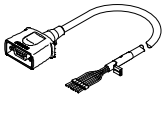
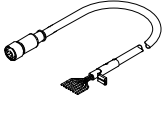
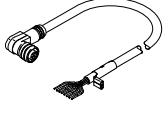
Ordering data – Cables ¹⁾					
	For size	Description	Cable length [m]	Part No.	Type
Motor cable					
	12, 16	Straight plug connector – Min. bending radius: 62 mm – Suitable for use with energy chains – Ambient temp.: –40 ... +80 °C	1.5	1449600	NEBM-M12G8-E-1.5-Q5-LE6
			2.5	1449601	NEBM-M12G8-E-2.5-Q5-LE6
			5.0	1449602	NEBM-M12G8-E-5-Q5-LE6
			7.0	1449603	NEBM-M12G8-E-7-Q5-LE6
			10.0	1449604	NEBM-M12G8-E-10-Q5-LE6
	25, 32	Angled plug connector – Min. bending radius: 62 mm – Suitable for use with energy chains – Ambient temp.: –40 ... +80 °C	1.5	1450736	NEBM-S1W9-E-1.5-Q5-LE6
			2.5	1450737	NEBM-S1W9-E-2.5-Q5-LE6
			5.0	1450738	NEBM-S1W9-E-5-Q5-LE6
			7.0	1450739	NEBM-S1W9-E-7-Q5-LE6
			10.0	1450740	NEBM-S1W9-E-10-Q5-LE6
	25, 32	Straight plug connector – Min. bending radius: 62 mm – Suitable for use with energy chains – Ambient temp.: –40 ... +80 °C	1.5	1450368	NEBM-S1G9-E-1.5-Q5-LE6
			2.5	1450369	NEBM-S1G9-E-2.5-Q5-LE6
			5.0	1450370	NEBM-S1G9-E-5-Q5-LE6
			7.0	1450371	NEBM-S1G9-E-7-Q5-LE6
			10.0	1450372	NEBM-S1G9-E-10-Q5-LE6
Encoder cable					
	12, 16, 25, 32	Straight plug connector – Min. bending radius: 68 mm – Suitable for use with energy chains – Ambient temp.: –40 ... +80 °C	1.5	1451586	NEBM-M12G8-E-1.5-LE8
			2.5	1451587	NEBM-M12G8-E-2.5-LE8
			5.0	1451588	NEBM-M12G8-E-5-LE8
			7.0	1451589	NEBM-M12G8-E-7-LE8
			10.0	1451590	NEBM-M12G8-E-10-LE8
	25, 32	Angled plug connector – Min. bending radius: 68 mm – Suitable for use with energy chains – Ambient temp.: –40 ... +80 °C	1.5	1451674	NEBM-M12W8-E-1.5-LE8
			2.5	1451675	NEBM-M12W8-E-2.5-LE8
			5.0	1451676	NEBM-M12W8-E-5-LE8
			7.0	1451677	NEBM-M12W8-E-7-LE8
			10.0	1451678	NEBM-M12W8-E-10-LE8

1) Other cable lengths on request.

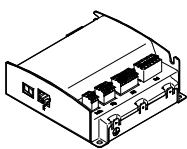
Ordering data – Motor controller		Technical data → Internet: cmmo	
	Description	Part No.	Type
	With I/O interface		
	Switching input/output PNP	1512316	CMMO-ST-C5-1-DIOP
	Switching input/output NPN	1512317	CMMO-ST-C5-1-DION
	With IO-Link		
	Switching input/output PNP	1512320	CMMO-ST-C5-1-LKP

Product Range and Company Overview

A Complete Suite and Company Overview

Our experienced engineers provide complete support at every stage of your development process, including: conceptualization, analysis, engineering, design, assembly, documentation, validation, and production.

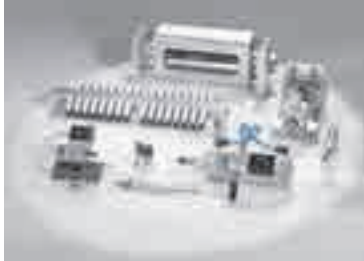

Custom Automation Components
Complete custom engineered solutions



Custom Control Cabinets
Comprehensive engineering support and on-site services



Complete Systems
Shipment, stocking and storage services

The Broadest Range of Automation Components

With a comprehensive line of more than 30,000 automation components, Festo is capable of solving the most complex automation requirements.



Electromechanical
Electromechanical actuators, motors, controllers & drivers



Pneumatics
Pneumatic linear and rotary actuators, valves, and air supply



PLCs and I/O Devices
PLC's, operator interfaces, sensors and I/O devices

Supporting Advanced Automation... As No One Else Can!

Festo is a leading global manufacturer of pneumatic and electromechanical systems, components and controls for industrial automation, with more than 16,000 employees in 60 national headquarters serving more than 180 countries. For more than 80 years, Festo has continuously elevated the state of manufacturing with innovations and optimized motion control solutions that deliver higher performing, more profitable automated manufacturing and processing equipment. Our dedication to the advancement of automation extends beyond technology to the education and development of current and future automation and robotics designers with simulation tools, teaching programs, and on-site services.

Quality Assurance, ISO 9001 and ISO 14001 Certifications

Festo Corporation is committed to supply all Festo products and services that will meet or exceed our customers' requirements in product quality, delivery, customer service and satisfaction.

To meet this commitment, we strive to ensure a consistent, integrated, and systematic approach to management that will meet or exceed the requirements of the ISO 9001 standard for Quality Management and the ISO 14001 standard for Environmental Management.



© Copyright 2013, Festo Corporation. While every effort is made to ensure that all dimensions and specifications are correct, Festo cannot guarantee that publications are completely free of any error, in particular typing or printing errors. Accordingly, Festo cannot be held responsible for the same. For Liability and Warranty conditions, refer to our "Terms and Conditions of Sale", available from your local Festo office. All rights reserved. No part of this publication may be reproduced, distributed, or transmitted in any form or by any means, electronic, mechanical, photocopying or otherwise, without the prior written permission of Festo. All technical data subject to change according to technical update.



Printed on recycled paper at New Horizon Graphic, Inc., FSC certified as an environmental friendly printing plant.

Festo North America

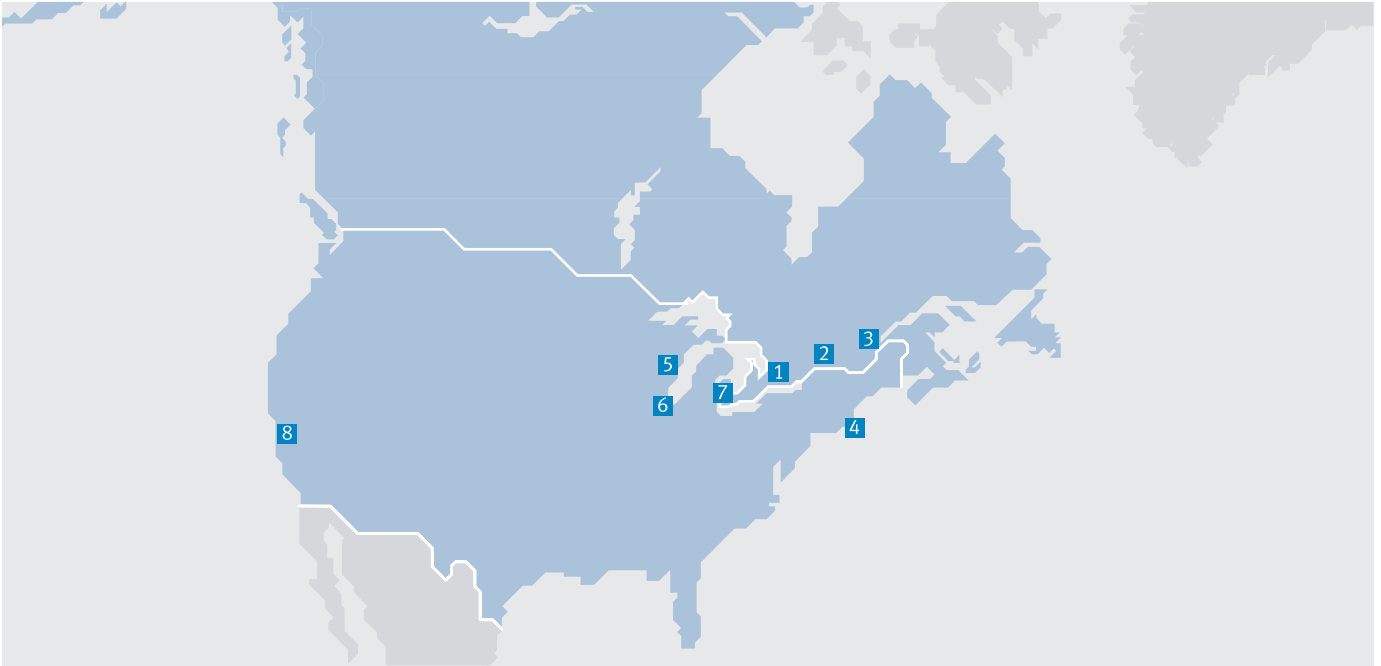

**1 Festo Canada
Headquarters
Festo Inc.**
5300 Explorer Drive
Mississauga, ON
L4W 5G4

2 Montréal
5600, Trans-Canada
Pointe-Claire, QC
H9R 1B6

3 Québec City
2930, rue Watt#117
Québec, QC
G1X 4G3



**4 Festo United States
Headquarters
Festo Corporation**
395 Moreland Road
Hauppauge, NY
11788

5 Appleton
North 922 Tower View Drive, Suite N
Greenville, WI
54942

7 Detroit
1441 West Long Lake Road
Troy, MI
48098

6 Chicago
85 W Algonquin - Suite 340
Arlington Heights, IL
60005

8 Silicon Valley
4935 Southfront Road, Suite F
Livermore, CA
94550

Festo Regional Contact Center

Canadian Customers

Commercial Support:
Tel: 1 877 GO FESTO (1 877 463 3786)
Fax: 1 877 FX FESTO (1 877 393 3786)
Email: festo.canada@ca.festo.com

Technical Support:

Tel: 1 866 GO FESTO (1 866 463 3786)
Fax: 1 877 FX FESTO (1 877 393 3786)
Email: technical.support@ca.festo.com

USA Customers

Commercial Support:
Tel: 1 800 99 FESTO (1 800 993 3786)
Fax: 1 800 96 FESTO (1 800 963 3786)
Email: customer.service@us.festo.com

Technical Support:

Tel: 1 866 GO FESTO (1 866 463 3786)
Fax: 1 800 96 FESTO (1 800 963 3786)
Email: product.support@us.festo.com