

Rotary modules ERMB, electric



# Rotary modules ERMB, electric

Key features

## At a glance

The rotary module ERMB facilitates unlimited and flexible rotation angles. The output interface is the same as on the semi-rotary drive DRQD.

The motor's power is transmitted to the output pinion by means of a circulating toothed belt with a specific transmission ratio. The drive and

output pinions run on separate bearings. The toothed belt is pretensioned at the factory by means of an eccentric tensioning roller.

Advantages:

- Stable arrangement of the output shaft bearings
- Pretensioned toothed belt means zero backlash
- Compact design

## The technology in detail

- 1 Interface with the motor, via axial kit
- 2 Mounting interface
- 3 Mounting for proximity sensor SIEN in the retaining ring
- 4 Output interface: Same as on the semi-rotary drive DRQD (with larger through-hole)

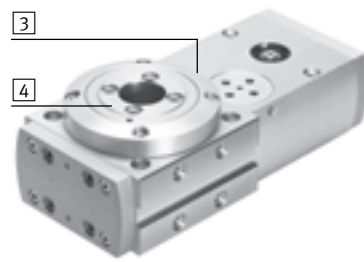
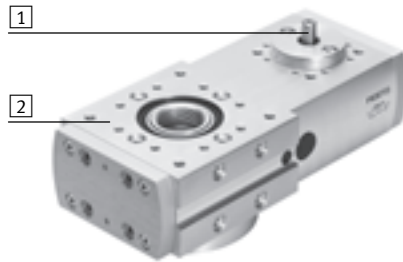

## Sensing kit EAPS as an accessory

→ 14

The sensing kit facilitates monitoring of the angle of rotation using adjustable cams. It can also be used for reference checking.

Without housing

With housing

- 1 Trip cam support
- 2 Proximity sensor SIEN
- 3 Sensor bracket
- 4 Housing

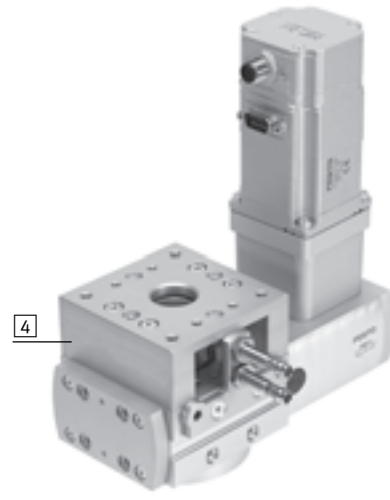
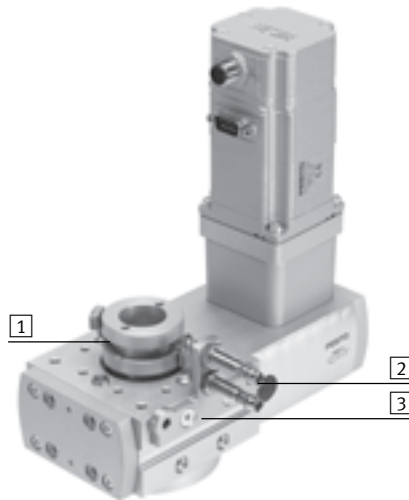

## Mounting and installation options

Mounting option

Installation option

The rotary module can be attached on six sides.

As a front end

As a rotary table in a plate

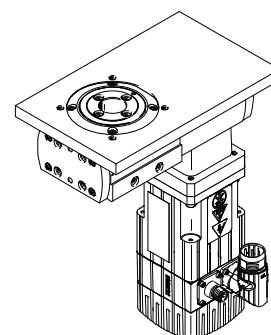
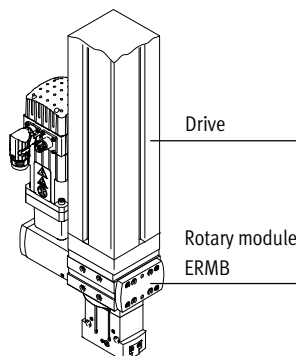
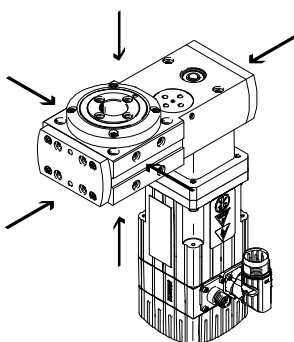

# Rotary modules ERMB, electric

Key features

## Total system comprising rotary module, motor and axial kit

Rotary module

→ 6

With axial kit

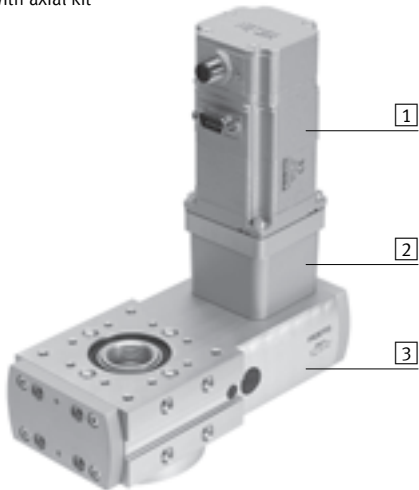

- 1 Motor
- 2 Axial kit
- 3 Rotary module

## Motors

→ 16

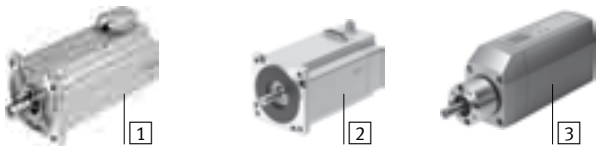

- 1 Servo motor EMME-AS, EMMS-AS
- 2 Stepper motor EMMS-ST
- 3 Motor unit MTR-DCI

 Note  
A range of specially adapted complete solutions is available for the rotary module ERMB.

## Motor controllers

Technical data → Internet: motor controller

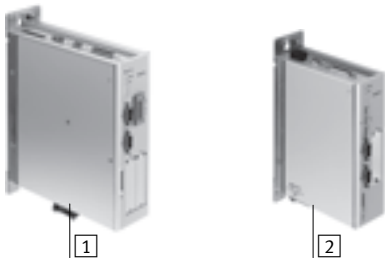

- 1 Servo motor controller CMMP-AS
- 2 Stepper motor controller CMMS-ST

## Axial kit

→ 16



- Kit comprising:
- Motor flange
  - Coupling housing
  - Coupling
  - Screws

# Rotary modules ERMB, electric

Key features

System product for handling and assembly technology

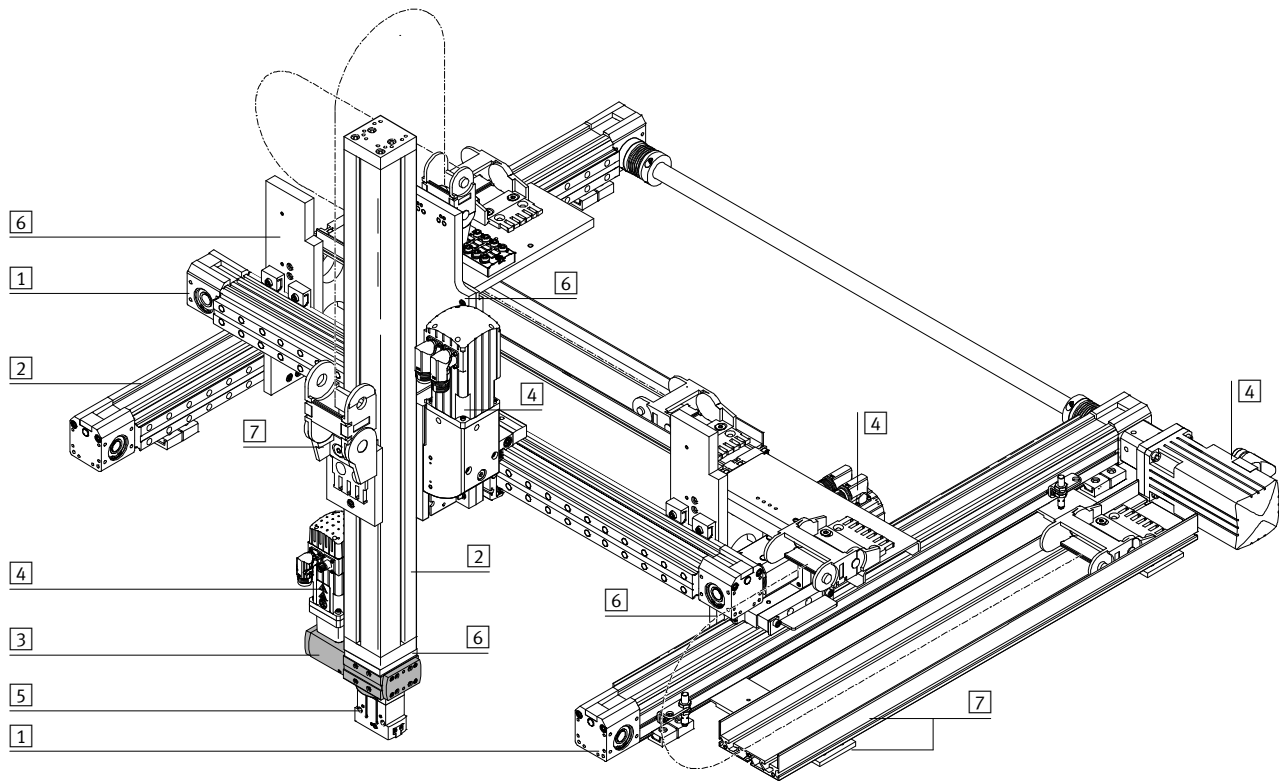

System components and accessories		
	Description	→ Page/Internet
1	Axes	Wide range of combinations possible within handling and assembly technology axes
2	Guide axes	For extending force and torque capacity in multi-axis applications guide axes
3	Rotary module	Wide range of combinations possible within handling and assembly technology rotary module
4	Motors	Servo or stepper motors, with or without gear unit motor
5	Gripper	Wide range of variations possible within handling and assembly technology gripper
6	Adapters	For drive/drive and drive/gripper connections adapter kit
7	Installation components	For a clean, safe layout of electrical cables and tubing installation component

# Rotary modules ERMB, electric

Type code and peripherals overview

## Type code

		ERMB	–	25
<b>Type</b>				
ERMB	Rotary module			
<b>Size</b>				
20	Size 20			
25	Size 25			
32	Size 32			

## Peripherals overview

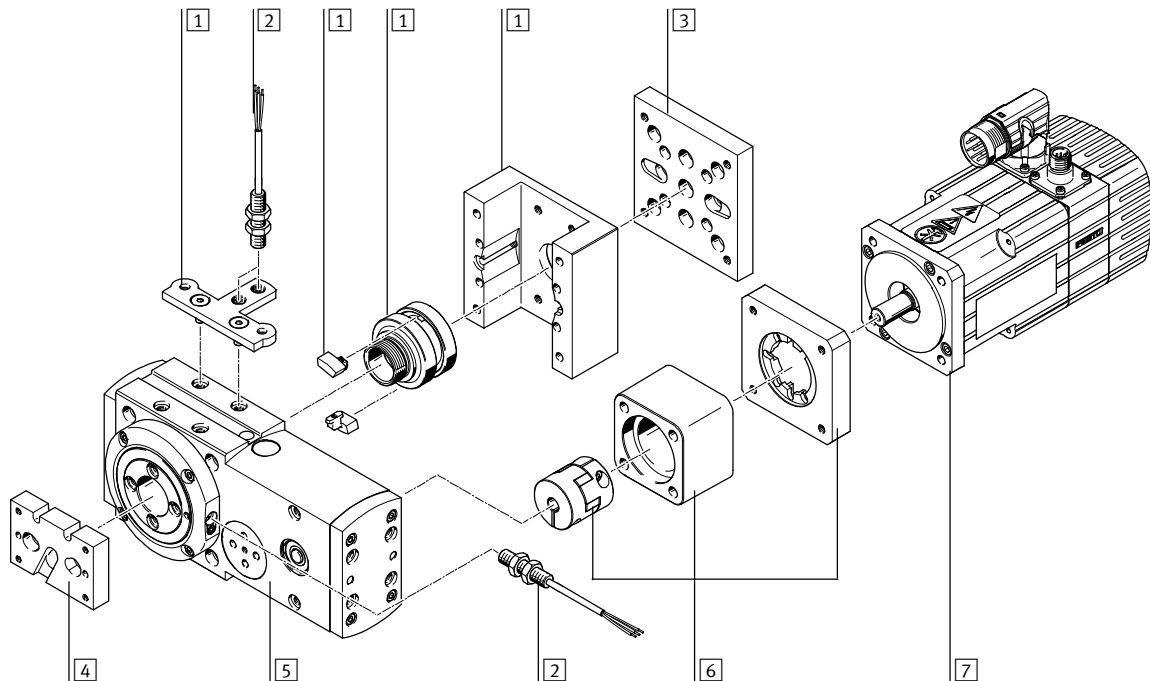

Accessories			
Type	Description	→ Page/Internet	
1 Sensing kit EAPS	For indicating impermissible swivel angles, i.e. obstacles or areas that cannot be approached can be sensed using proximity sensors (comprising: housing, trip cam support, 2 cams and sensor bracket)	19	
2 Proximity sensor SIEN	For use as a signal or safety check	19	
3 Adapter kit	Interface between the rotary module and drive (the rotary module can be attached to a drive with or without a sensing kit)	adapter kit	
4 Adapter kit	Interface between the rotary module and gripper	adapter kit	
5 Rotary module ERMB	Facilitates unlimited and flexible rotation angles	6	
6 Axial kit EAMM-A	For axial motor mounting (comprising: coupling, coupling housing and motor flange)	16	
7 Motor EMMS, MTR-DCI	<ul style="list-style-type: none"> <li>• Motors specially matched to the axis, with or without brake</li> <li>• The motor can be turned by 90° for mounting, depending on requirements. This means the connection side can be freely selected</li> </ul>	16	

# Rotary modules ERMB, electric

FESTO

Technical data

Size  
20, 25, 32



General technical data			
Size	20	25	32
Constructional design	Electromechanical rotary module with toothed belt		
Drive shaft $\varnothing$ [mm]	6	8	12
Rotation angle	Infinite		
Repetition accuracy <sup>1)</sup>			
with servo motor EMMS-AS [°]	±0.03		
with stepper motor EMMS-ST <sup>2)</sup> [°]	±0.08		
with motor unit MTR-DCI [°]	±0.05		
Positioning times	→ 8		
Transmission ratio	4.5:1	4:1	3:1
Position sensing	Via proximity sensor		
Mounting position	Any		
Product weight [g]	850	1460	3250

- 1) As per FN 942 027. The specifications apply only when the motor is directly mounted. If a gear unit is also installed, the repetition accuracy will be different  
2) Depends on the encoder resolution

Mechanical data			
Size	20	25	32
Max. driving torque [Nm]	0.7	2.2	8.5
Max. output torque <sup>1)</sup> [Nm]	3.15	8.8	25.5
Average driving torque <sup>2)</sup> [Nm]	< 0.07	< 0.18	≤ 0.5
Max. input speed [rpm]	1350	1200	900
Max. output speed [rpm]	300	300	300
Max. mass moment of inertia <sup>3)</sup>			
with servo motor EMMS-AS [kgcm <sup>2</sup> ]	50	200	1000
with stepper motor EMMS-ST [kgcm <sup>2</sup> ]	30	100	500
with motor unit MTR-DCI-...-G7 [kgcm <sup>2</sup> ]	50	300	1000
with motor unit MTR-DCI-...-G14 [kgcm <sup>2</sup> ]	200	1200	3700
Toothed belt pitch	2	3	5
Hollow shaft $\varnothing$ [mm]	20	24	28

- 1) Output torque less friction depends on speed  
2) At maximum speed  
3) Depends on the size of the motor. Suitable motors → 16

Operating and environmental conditions			
Size	20	25	32
Ambient temperature [°C]	-10 ... +60		
Protection class	IP20		
Corrosion resistance class CRC <sup>1)</sup>	2		
Noise level $L_{pEq}$ <sup>2)</sup> [dB (A)]	32	49	53

- 1) Corrosion resistance class CRC 2 to Festo standard FN 940070  
Moderate corrosion stress. Indoor applications in which condensation may occur. External visible parts with primarily decorative requirements for the surface and which are in direct contact with the ambient atmosphere typical for industrial applications.  
2) In combination with servo motor EMMS-AS

# Rotary modules ERMB, electric

Technical data

## Materials

Sectional view

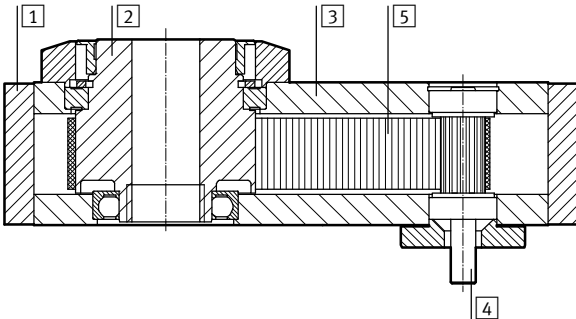

## Rotary module

1	End cap	Anodised aluminium
2	Output shaft	Wrought aluminium alloy, anodised
3	Housing	Wrought aluminium alloy, anodised
4	Drive shaft	High-alloy stainless steel
5	Toothed belt	Polychloroprene with glass fibres
-	Note on materials	Contains paint wetting impairment substances

## Maximum radial and axial force Fx/Fy on the output shaft as a function of the distance y/z

If the rotary module is subjected to several forces at once, the following equation must be satisfied in addition to the maximum loads indicated below.

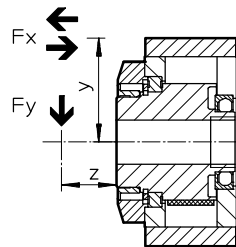

$$\frac{F_{y(z)}}{F_{y, \max. (z)}} + \frac{F_{x, \text{pushing} (v)}}{F_{x, \text{pushing, max.} (v)}} + \frac{F_{x, \text{pulling} (v)}}{F_{x, \text{pulling, max.} (v)}} \leq 1$$

Max. radial force Fy, static

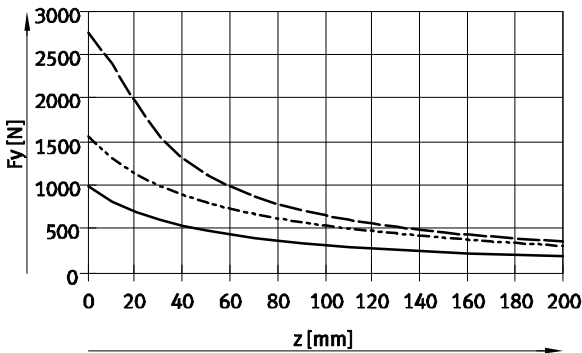

Max. radial force Fy, dynamic

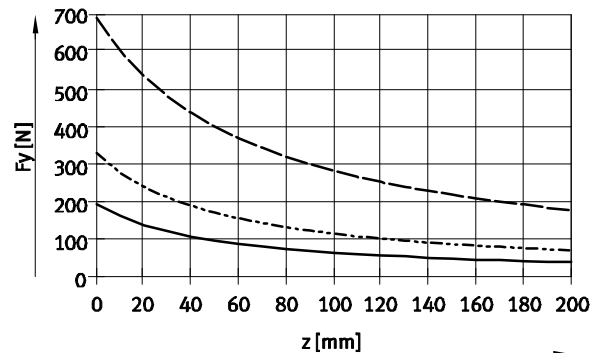

Max. axial force Fx, static, pushing and pulling

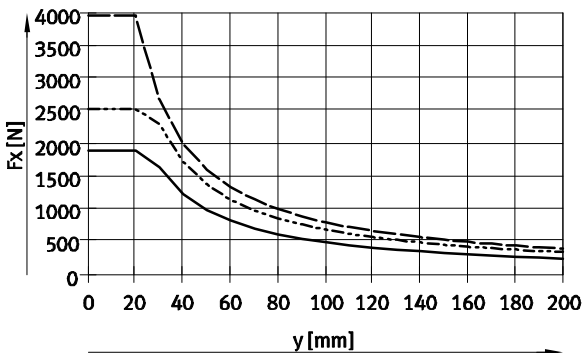

Max. axial force Fx, dynamic, pushing and pulling

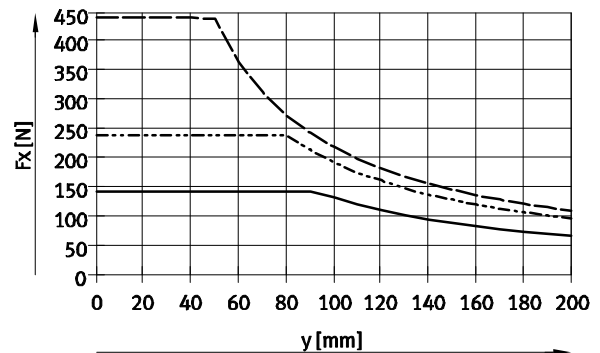

- ERMB-20
- - - ERMB-25
- · - ERMB-32

# Rotary modules ERMB, electric

Technical data

## Positioning time $t$ as a function of the rotation angle $\alpha$ in combination with motor EMMS-.../motor unit MTR-DCI-...

Size 20

with servo motor EMMS-AS

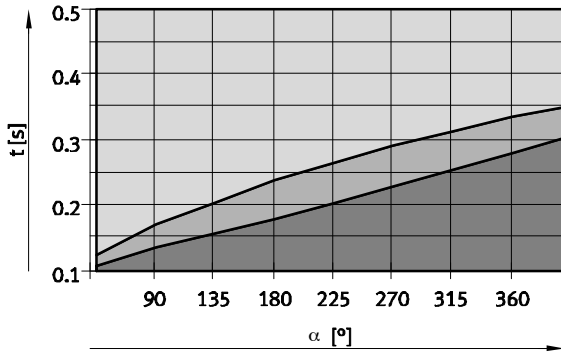

- Extended operating range
- Typical operating range, depending on motor size and load inertia
- Unrealisable range

with stepper motor EMMS-ST

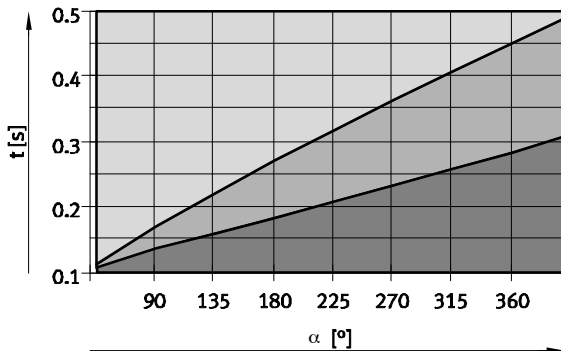

- Extended operating range
- Typical operating range, depending on motor size and load inertia
- Unrealisable range

with motor unit MTR-DCI

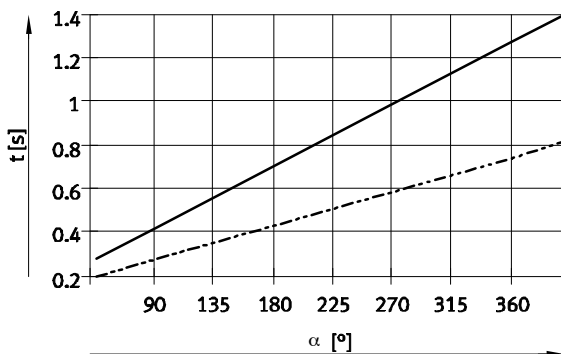

- Limit line for MTR-DCI-32-G14 at 0 ... 200 kgcm<sup>2</sup>
- Limit line for MTR-DCI-32-G7 at 0 ... 50 kgcm<sup>2</sup>

Note

The positioning time  $t$  ends with the controller signal MC (motion complete), i.e. on the drive side. Increased positioning times are to be expected at the output shaft depending on the motor type and eccentricity of the moving load.

For servo motor: 50 ... 100 ms  
For stepper motor: 100 ... 200 ms

Note

The "PositioningDrives" design tool compiles the optimum combination of rotary module and motor for the respective application with respect to mass moment of inertia, positioning time and positioning accuracy.

➔ [www.festo.com](http://www.festo.com)



# Rotary modules ERMB, electric

Technical data

## Positioning time $t$ as a function of the rotation angle $\alpha$ in combination with motor EMMS-.../motor unit MTR-DCI-...

Size 25

with servo motor EMMS-AS

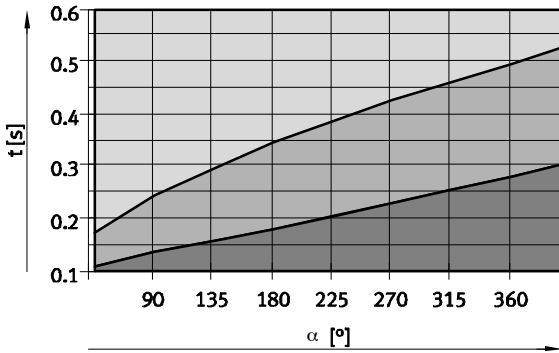

- Extended operating range
- Typical operating range, depending on motor size and load inertia
- Unrealisable range

with stepper motor EMMS-ST

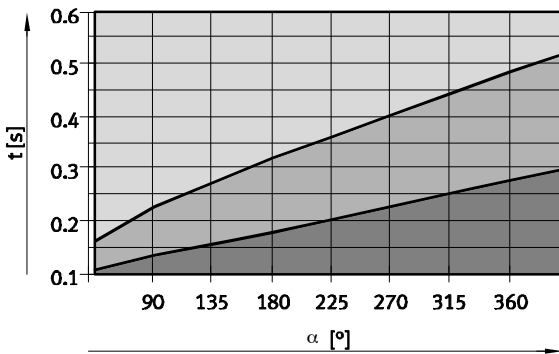

- Extended operating range
- Typical operating range, depending on motor size and load inertia
- Unrealisable range

with motor unit MTR-DCI

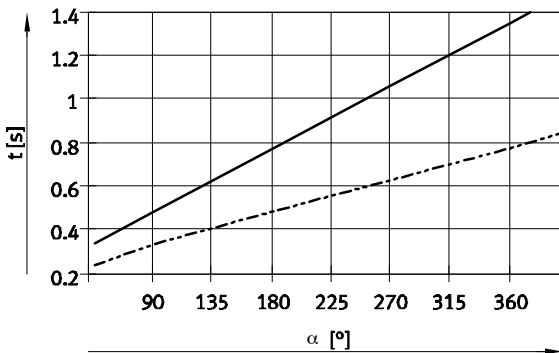

- Limit line for MTR-DCI-42-G14 at 0 ... 1200 kgcm<sup>2</sup>
- Limit line for MTR-DCI-42-G7 at 0 ... 300 kgcm<sup>2</sup>

Note

The positioning time  $t$  ends with the controller signal MC (motion complete), i.e. on the drive side. Increased positioning times are to be expected at the output shaft depending on the motor type and eccentricity of the moving load.

For servo motor: 50 ... 100 ms  
For stepper motor: 100 ... 200 ms

Note

The "PositioningDrives" design tool compiles the optimum combination of rotary module and motor for the respective application with respect to mass moment of inertia and positioning time, positioning accuracy.  
→ [www.festo.com](http://www.festo.com)

# Rotary modules ERMB, electric

Technical data

## Positioning time $t$ as a function of the rotation angle $\alpha$ in combination with motor EMMS-.../motor unit MTR-DCI-...

Size 32

with servo motor EMMS-AS

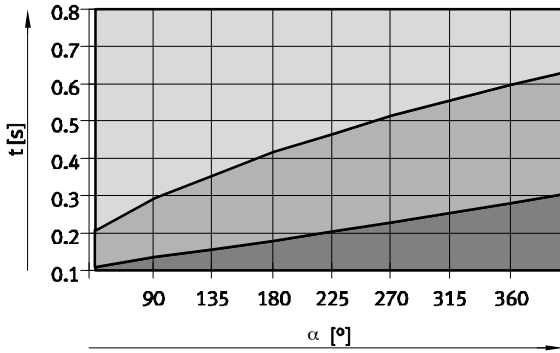

- Extended operating range
- Typical operating range, depending on motor size and load inertia
- Unrealisable range

with stepper motor EMMS-ST

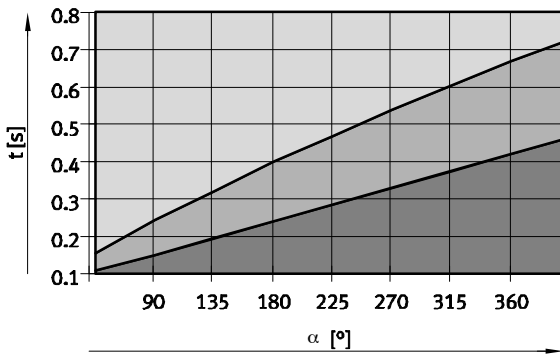

- Extended operating range
- Typical operating range, depending on motor size and load inertia
- Unrealisable range

with motor unit MTR-DCI

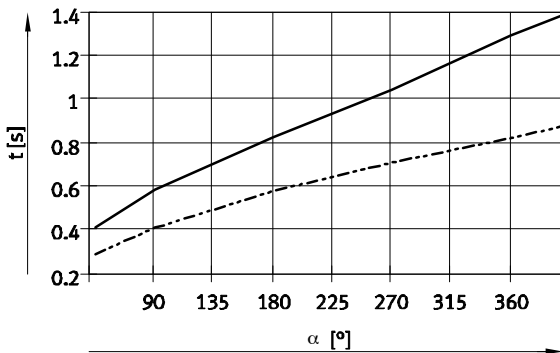

- Limit line for MTR-DCI-52-G14 at 0 ... 3700 kgcm<sup>2</sup>
- Limit line for MTR-DCI-52-G7 at 0 ... 1000 kgcm<sup>2</sup>

Note

The positioning time  $t$  ends with the controller signal MC (motion complete), i.e. on the drive side. Increased positioning times are to be expected at the output shaft depending on the motor type and eccentricity of the moving load.

For servo motor: 50 ... 100 ms  
For stepper motor: 100 ... 200 ms

Note

The "PositioningDrives" design tool compiles the optimum combination of rotary module and motor for the respective application with respect to mass moment of inertia and positioning time, positioning accuracy.  
→ [www.festo.com](http://www.festo.com)

# Rotary modules ERMB, electric

Technical data

## Information on service life characteristic values

Within the framework of product qualification, the specified statistic load changes/switching cycles were achieved with 3 samples.

### Definition of load change/switching cycle:

A switching cycle corresponds to two load changes: position A to position B and back.

Size		20	25	32
Guide value load changes	[Mio.]	30	40	40
Guide value switching cycles	[Mio.]	15	20	20
Mass moment of inertia at output	[kgcm <sup>2</sup> ]	24	80	400
Medium angle acceleration at output	[°/sec <sup>2</sup> ]	28000	20000	12000
Maximum angle speed at output	[°/sec]	1800	1800	1800

The above specified statistic load change/switching cycles were achieved under the following defined operating conditions: horizontally hanging fitting, 180° swivel angle,

frequency 2 Hz, mass moment of inertia, acceleration (jerk-free) and max. angle speed as specified in the table, room temperature (23 ± 5) °C.

Under different operating conditions, a shorter or longer service life is possible.

The conditions of use and safety regulations specified in the product documentation must also be taken into account.

## Dimensions

Download CAD data → [www.festo.com](http://www.festo.com)

Size 20

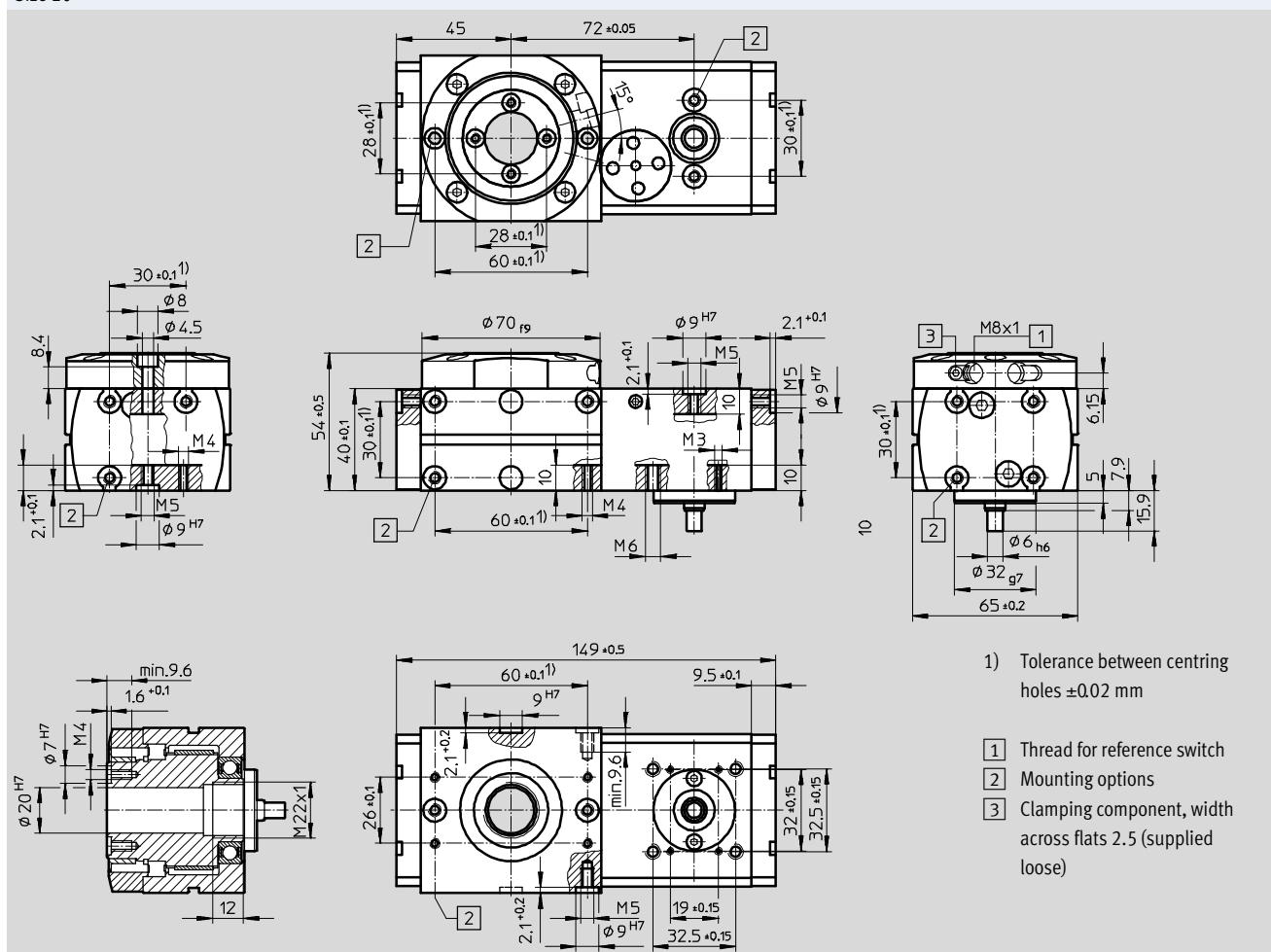

1) Tolerance between centring holes ±0.02 mm

- 1) Thread for reference switch
- 2) Mounting options
- 3) Clamping component, width across flats 2.5 (supplied loose)



# Rotary modules ERMB, electric

Technical data

Size	B1 ±0.2	D1 ∅ f9	D2 ∅ h6	D3 ∅ g7	D4 ∅ H7	D5	D6 ∅ H7	D7	D8	D9	D10
25	85	80	8	40	24	M25x1	9	M5	M6	M6	M4
32	115	112	12	60	28	M32x1.5	9	M5	M6	M8	M5

Size	D11 ∅	D12 ∅	D13 ∅ H7	D14	H1 ±0.5	H2 ±0.1	H3	H4	H5	H6	L1 ±0.5
25	10	6.2	-	-	60	46	18.45	-	7	6.3	185
32	10	6.2	7	M4	76.05	60	23.5	6.5	6	9.4	222

Size	L2 ±0.2	L3 ±0.1	L4 ±0.1	L5 <sup>1)</sup> ±0.1	L6	L7 ±0.15	L8 ±0.15	L9 <sup>1)</sup> ±0.1	L10	L11 ±0.05	L12 <sup>1)</sup> ±0.1	L13 <sup>1)</sup> ±0.1
25	85	9.5	26	60	64±0.15	20	38	30	52	96	34	-
32	100	13	36	80	88±0.1	31	56.5	40	63	108	45	30

Size	L14 ±0.15	L15 ±0.15	L16 +0.2	T1	T2 +0.1	T3 min.	T4	T5 min.	T6	T7 +0.1	T8 min.	T9 +0.2
25	38	42	-	12	2.1	12	10	9.6	40.8±0.2	-	-	2.1
32	56.5	62	103	12	2.1	12	10	10	54.3	1.6	7.6	2.1

1) Tolerance between centring holes ±0.02 mm

# Rotary modules ERMB, electric

Technical data

FESTO

## Dimensions

Download CAD data → [www.festo.com](http://www.festo.com)

Sensing kit EAPS-R1-20-S for size 20

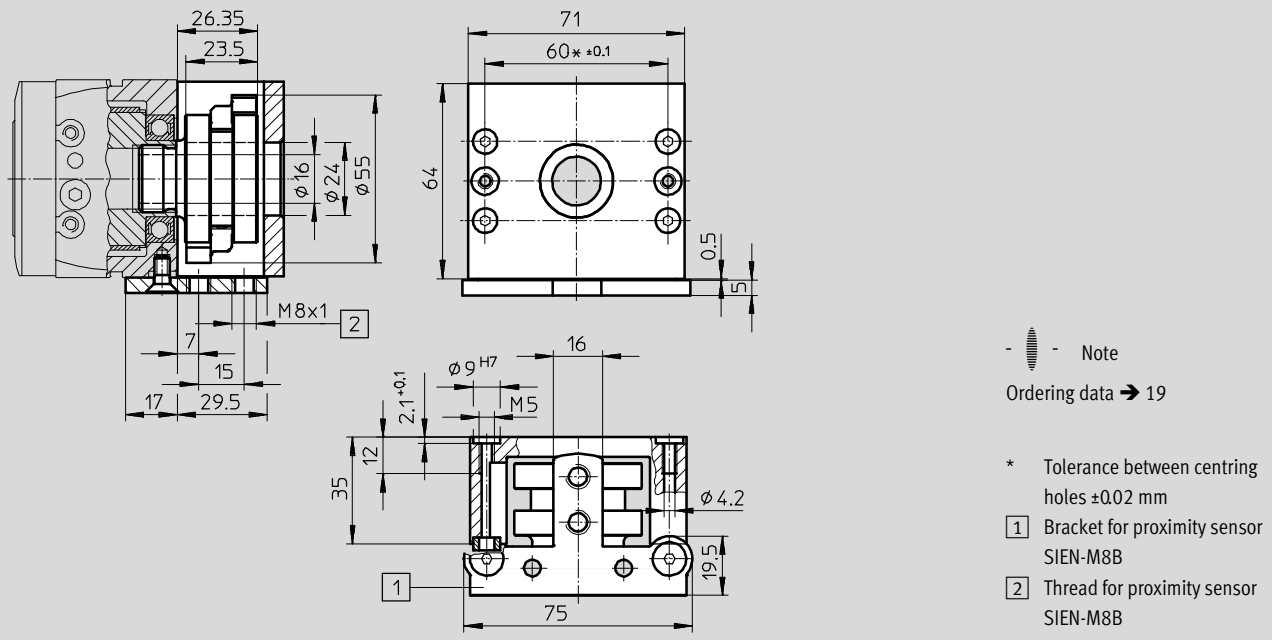

Sensing kit EAPS-R1-25-S for size 25

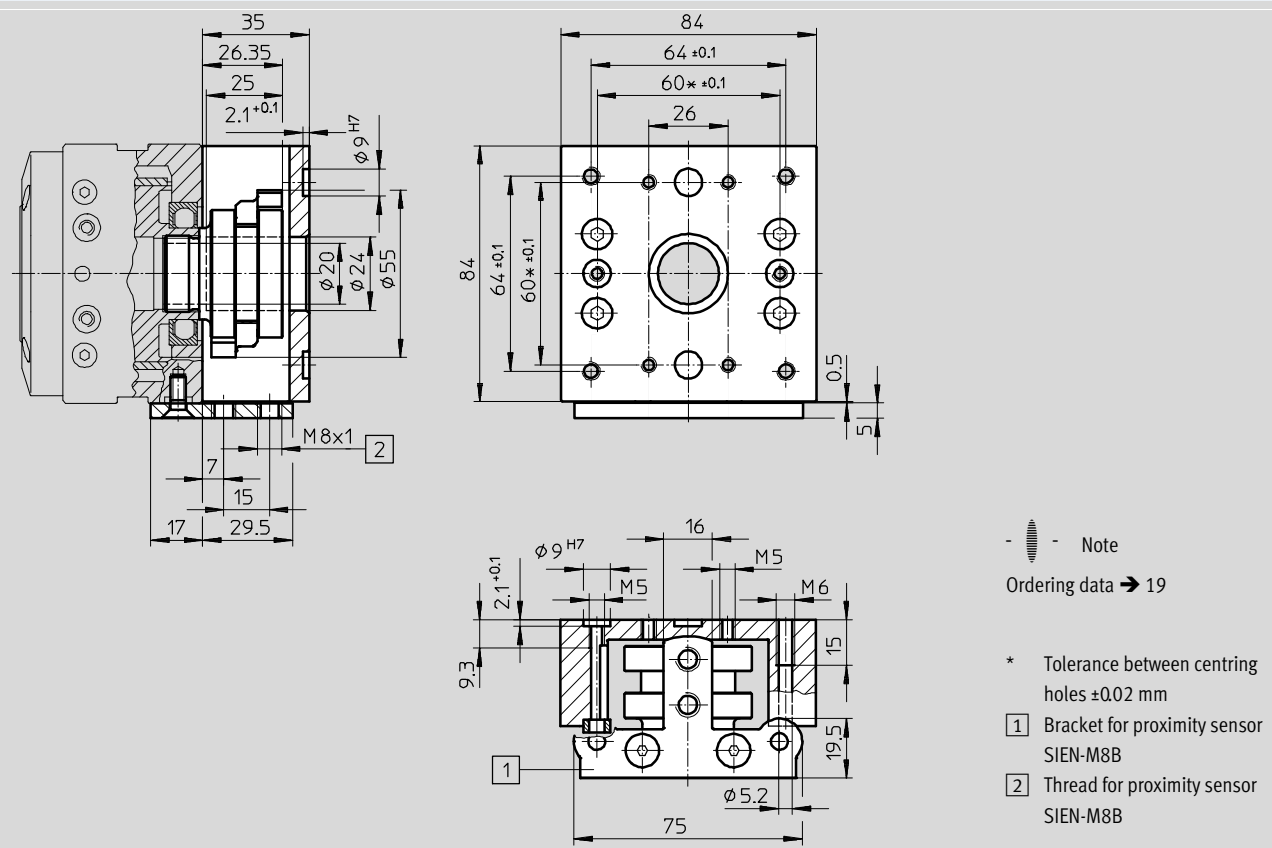

# Rotary modules ERMB, electric

Technical data

## Dimensions

Download CAD data → [www.festo.com](http://www.festo.com)

Sensing kit EAPS-R1-32-S for size 32

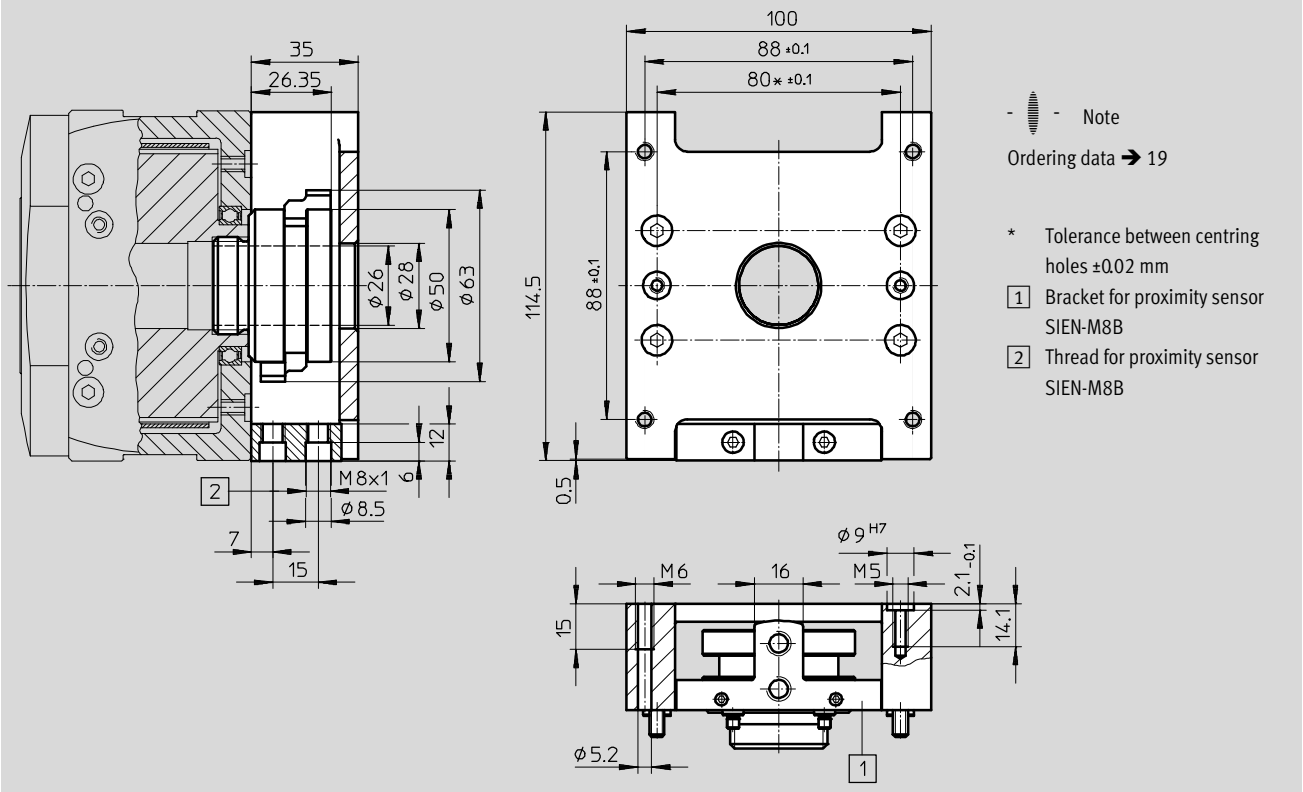

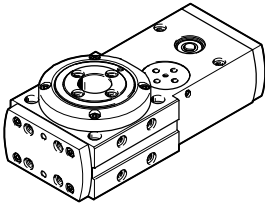

# Rotary modules ERMB, electric

Technical data and accessories

Ordering data			
	Size	Part No.	Type
	20	552706	ERMB-20
	25	552707	ERMB-25
	32	552708	ERMB-32

## Accessories

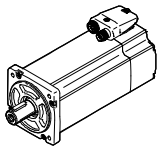
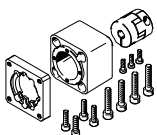
-  - Note  
 Depending on the combination of motor and drive, it may not be possible to reach the maximum feed force of the drive.

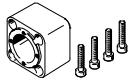
Permissible axis/motor combinations with axial kit – Without gear unit				
Motor/motor unit <sup>1)</sup>	Axial kit	Axial kit comprising:		
		Motor flange	Coupling	Coupling housing
				
Type	Part No. Type	Part No. Type	Part No. Type	Part No. Type
<b>ERMB-20</b>				
with servo motor				
EMME-AS-40-...	2207441 EAMM-A-D32-35A-40P	–	533708 EAMC-30-32-6-8	2207509 EAMK-A-D32-35-40P
EMMS-AS-40-...	560281 EAMM-A-D32-35A-40A	–	558312 EAMC-30-32-6-6	560280 EAMK-A-D32-35-40A
with stepper motor				
EMMS-ST-42-...	543148 EAMM-A-D32-42A	552164 EAMF-A-28B-42A	543419 EAMC-16-20-5-6	552155 EAMK-A-D32-28B
EMMS-ST-57-...	550980 EAMM-A-D32-57A	530081 EAMF-A-44A/B-57A	551002 EAMC-30-32-6-6.35	551006 EAMK-A-D32-44A/C
with integrated drive				
EMCA-EC-67-...	1454239 EAMM-A-D32-67A	1476305 EAMF-A-44A/B/C-67A-S1	551003 EAMC-30-32-6-9	551006 EAMK-A-D32-44A/C
With motor unit				
MTR-DCI-32S-...	543149 EAMM-A-D32-32B	–	543420 EAMC-16-20-6-6	552156 EAMK-A-D32-32B



1) The input torque must not exceed the maximum permissible transferable torque of the axial kit.



# Rotary modules ERMB, electric

Accessories

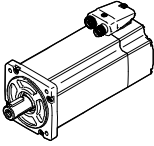
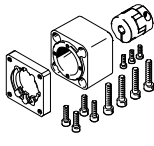
FESTO

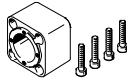

Permissible axis/motor combinations with axial kit – Without gear unit				Technical data → Internet: eamm-a
Motor <sup>1)</sup>	Axial kit	Axial kit consisting of:		
		Motor flange	Coupling	Coupling housing
				
Type	Part No. Type	Part No. Type	Part No. Type	Part No. Type
<b>ERMB-25</b>				
With servo motor				
EMMS-AS-55-...	543153 EAMM-A-D40-55A	529942 EAMF-A-44A/B-55A	543423 EAMC-30-32-8-9	552157 EAMK-A-D40-44A/C
EMME-AS-60-...	1977000 EAMM-A-D40-60P	1956846 EAMF-A-44C-60P	562682 EAMC-30-32-8-14	552157 EAMK-A-D40-44A/C
EMMS-AS-70-...	550981 EAMM-A-D40-70A	529943 EAMF-A-44A/B-70A	551004 EAMC-30-32-8-11	552157 EAMK-A-D40-44A/C
With stepper motor				
EMMS-ST-57-...	543154 EAMM-A-D40-57A	530081 EAMF-A-44A/B-57A	543421 EAMC-30-32-6.35-8	552157 EAMK-A-D40-44A/C
With integrated drive				
EMCA-EC-67-...	1454243 EAMM-A-D40-67A	1476305 EAMF-A-44A/B/C-67A-S1	543423 EAMC-30-32-8-9	552157 EAMK-A-D40-44A/C
With motor unit				
MTR-DCI-42S-...-G7	543155 EAMM-A-D40-42B	–	543422 EAMC-30-32-8-8	552158 EAMK-A-D40-42B
MTR-DCI-42S-...-G14	543156 EAMM-A-D40-42C	–	543422 EAMC-30-32-8-8	552159 EAMK-A-D40-42C
<b>ERMB-32</b>				
With servo motor				
EMMS-AS-70-...	543161 EAMM-A-D60-70A	529945 EAMF-A-64A/B-70A	543424 EAMC-42-50-11-12	552160 EAMK-A-D60-64B
EMME-AS-80-...	1977073 EAMM-A-D60-80P	1977113 EAMF-A-64A/C-80P	551005 EAMC-42-50-12-19	551007 EAMK-A-D60-64C
EMME-AS-100-...	550983 EAMM-A-D60-100A	529947 EAMF-A-64A/C/D-100A	551005 EAMC-42-50-12-19	551007 EAMK-A-D60-64C
EMMS-AS-100-...	550983 EAMM-A-D60-100A	529947 EAMF-A-64A/C/D-100A	551005 EAMC-42-50-12-19	551007 EAMK-A-D60-64C
With stepper motor				
EMMS-ST-87-...	543162 EAMM-A-D60-87A	533140 EAMF-A-64A/B-87A	543424 EAMC-42-50-11-12	552160 EAMK-A-D60-64B
With motor unit				
MTR-DCI-52S-...-G7	543163 EAMM-A-D60-52B	–	533709 EAMC-42-50-12-12	552161 EAMK-A-D60-52B
MTR-DCI-52S-...-G14	543164 EAMM-A-D60-52C	–	533709 EAMC-42-50-12-12	552162 EAMK-A-D60-52C

1) The input torque must not exceed the maximum permissible transferable torque of the axial kit.

# Rotary modules ERMB, electric

Accessories

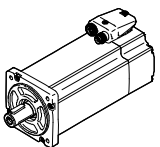
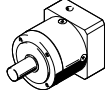
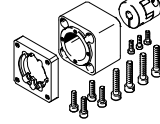
FESTO

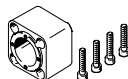
Permissible axis/motor combinations with axial kit – With gear unit						Technical data → Internet: eamm-a
Motor <sup>1)</sup>	Gear unit	Axial kit	Axial kit consisting of:			
			Motor flange	Coupling	Coupling housing	
						
Type	Type	Part No. Type	Part No. Type	Part No. Type	Part No. Type	
<b>ERMB-20</b>						
With integrated drive						
EMCA-EC-67-...	EMGC-40-...	1454238 EAMM-A-D32-40G	1460095 EAMF-A-44C-40G-S	562681 EAMC-30-32-6-10	551006 EAMK-A-D32-44A/C	
	EMGC-60-...	2946760 EAMM-A-D32-60H	1460105 EAMF-A-44C-60G/H-S1	1233256 EAMC-30-32-6-14	551006 EAMK-A-D32-44A/C	
<b>ERMB-25</b>						
With servo motor						
EMME-AS-40-...	EMGA-40-P-G...-EAS-40	560282 EAMM-A-D40-40G	550986 EAMF-A-44A/B-40G	558029 EAMC-30-32-8-10	552157 EAMK-A-D40-44A/C	
EMMS-AS-40-...	EMGA-40-P-G...-SAS-40	560282 EAMM-A-D40-40G	550986 EAMF-A-44A/B-40G	558029 EAMC-30-32-8-10	552157 EAMK-A-D40-44A/C	
With stepper motor						
EMME-ST-42-...	EMGA-40-P-G...-SST-42	560282 EAMM-A-D40-40G	550986 EAMF-A-44A/B-40G	558029 EAMC-30-32-8-10	552157 EAMK-A-D40-44A/C	
With integrated drive						
EMCA-EC-67-...	EMGC-40-...	560282 <sup>2)</sup> EAMM-A-D40-40G	550986 EAMF-A-44A/B-40G	558029 EAMC-30-32-8-10	552157 EAMK-A-D40-44A/C	
		2256398 EAMM-A-D40-40G-G2	1460095 EAMF-A-44C-40G-S	558029 EAMC-30-32-8-10	552157 EAMK-A-D40-44A/C	
	EMGC-60-...	1454242 EAMM-A-D40-60H	1460105 EAMF-A-44C-60G/H-S1	562682 EAMC-30-32-8-14	552157 EAMK-A-D40-44A/C	
<b>ERMB-32</b>						
With servo motor						
EMMS-AS-55-...	EMGA-60-P-G...-SAS-55	560283 EAMM-A-D60-60G	550987 EAMF-A-64A/B-60G	543424 EAMC-42-50-11-12	552160 EAMK-A-D60-64B	
EMMS-AS-70-...	EMGA-60-P-G...-SAS-70	560283 EAMM-A-D60-60G	550987 EAMF-A-64A/B-60G	543424 EAMC-42-50-11-12	552160 EAMK-A-D60-64B	
With stepper motor						
EMMS-ST-57-...	EMGA-60-P-G...-SST-57	560283 EAMM-A-D60-60G	550987 EAMF-A-64A/B-60G	543424 EAMC-42-50-11-12	552160 EAMK-A-D60-64B	
With integrated drive						
EMCA-EC-67-...	EMGC-60-...	1454245 EAMM-A-D60-60H	2256289 EAMF-A-64B-60G/H-S1	1455671 EAMC-42-50-12-14	552160 EAMK-A-D60-64B	

- 1) The input torque must not exceed the maximum permissible transferable torque of the axial kit.  
 2) Type discontinued

 Note  
 Note the maximum permissible drive torque of the ERMB. The motor current may need to be limited.





# Rotary modules ERMB, electric

Accessories

FESTO

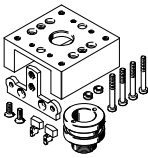
Ordering data – Centring sleeves						
	For size	Brief description	Number	Part No.	Type	PU <sup>1)</sup>
	20	For centring loads and attachments (centring sleeves are included in the scope of delivery of the rotary module)	2	<b>186717</b>	<b>ZBH-7</b>	10
	25, 32		2	<b>150927</b>	<b>ZBH-9</b>	
			4			

1) Packaging unit

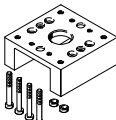
Ordering data						
	For size	Brief description	Weight [g]	Part No.	Type	PU <sup>1)</sup>
<b>Sensing kit EAPS-...-S</b>						
	20	Kit with housing (trip cam support, 2 cams, sensor bracket)	258	<b>558392</b>	<b>EAPS-R1-20-S</b>	1
	25		406	<b>558393</b>	<b>EAPS-R1-25-S</b>	
	32		560	<b>558394</b>	<b>EAPS-R1-32-S</b>	
<b>Sensing kit without housing EAPS-...-S-WH</b>						
	20	Kit without housing (trip cam support, 2 cams, sensor bracket)	86	<b>558395</b>	<b>EAPS-R1-20-S-WH</b>	1
	25		90	<b>558396</b>	<b>EAPS-R1-25-S-WH</b>	
	32		136	<b>558397</b>	<b>EAPS-R1-32-S-WH</b>	
<b>Cam EAPS-...-CK</b>						
	20, 25, 32	For sensing positions (2 cams included in the scope of delivery)	5 each	<b>558398</b>	<b>EAPS-R1-CK</b>	2
<b>Sensor bracket EAPS-...-SH</b>						
	20, 25	For attaching proximity sensors to the rotary module	24	<b>558399</b>	<b>EAPS-R1-20-SH</b>	1
	32		30	<b>558400</b>	<b>EAPS-R1-32-SH</b>	
<b>Housing EAPS-...-H</b>						
	20	For protecting the sensing kit and as mounting interface for the drive	172	<b>560673</b>	<b>EAPS-R1-20-H</b>	1
	25		316	<b>560674</b>	<b>EAPS-R1-25-H</b>	
	32		424	<b>560675</b>	<b>EAPS-R1-32-H</b>	

Ordering data – Proximity sensors, inductive				Technical data → Internet: sien		
	Contact	Connection	Part No.	Type		
	N/O contact	Cable, 2.5 m	<b>150386</b>	<b>SIEN-M8B-PS-K-L</b>		
		Plug connector	<b>150387</b>	<b>SIEN-M8B-PS-S-L</b>		
	N/C contact	Cable, 2.5 m	<b>150390</b>	<b>SIEN-M8B-PO-K-L</b>		
		Plug connector	<b>150391</b>	<b>SIEN-M8B-PO-S-L</b>		

Ordering data – Connecting cables				Technical data → Internet: nebu		
	Electrical connection, left	Electrical connection, right	Cable length [m]	Part No.	Type	
	Straight socket, M8x1, 3-pin	Cable, open end, 3-wire	2.5	<b>541333</b>	<b>NEBU-M8G3-K-2.5-LE3</b>	
			5	<b>541334</b>	<b>NEBU-M8G3-K-5-LE3</b>	

# Rotary modules ERMB, electric

Accessories



**Adapter kit**  
**HAPB, HMSV**

Material:  
Wrought aluminium alloy  
Free of copper and PTFE  
RoHS-compliant

 Note  
The kit includes the individual mounting interface as well as the necessary mounting material.

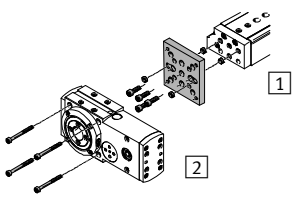
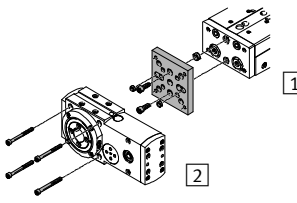
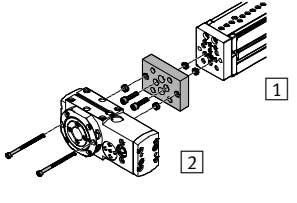
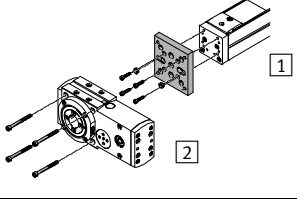
Permissible drive/drive combinations with adapter kit				Download CAD data → <a href="http://www.festo.com">www.festo.com</a>	
Combination	1	2	Adapter kit		
	Drive	Drive	CRC <sup>1)</sup>	Part No.	Type
DGSL/ERMB	DGSL	ERMB	HAPB		
	16, 20, 25	20	2	558306	HAPB-38
	20, 25	25		558307	HAPB-39
	25	32		558308	HAPB-40
SLT/ERMB	SLT	ERMB	HAPB		
	20	20	2	558306	HAPB-38
	25	25		558307	HAPB-39
EGSL/ERMB	EGSL	ERMB	HAPB		
	45, 55, 75	20	2	558306	HAPB-38
	75	25		558307	HAPB-39
	75	32		558308	HAPB-40
DGEA/ERMB	DGEA	ERMB	HAPB		
	18, 25	20	2	558306	HAPB-38
	25, 40	25		558307	HAPB-39
	40	32		558308	HAPB-40

1) Corrosion resistance class CRC 2 to Festo standard FN 940070  
Moderate corrosion stress. Indoor applications in which condensation may occur. External visible parts with primarily decorative requirements for the surface and which are in direct contact with the ambient atmosphere typical for industrial applications.

## Product Range and Company Overview

### A Complete Suite and Company Overview

Our experienced engineers provide complete support at every stage of your development process, including: conceptualization, analysis, engineering, design, assembly, documentation, validation, and production.

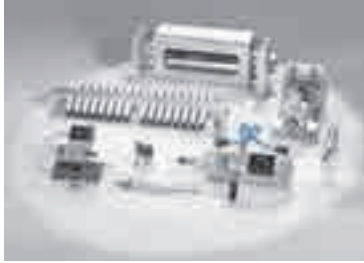

**Custom Automation Components**  
Complete custom engineered solutions



**Custom Control Cabinets**  
Comprehensive engineering support and on-site services

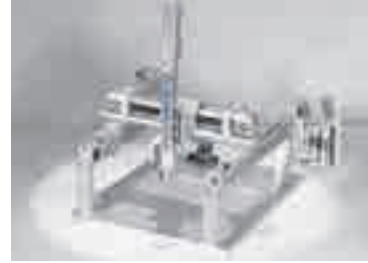

**Complete Systems**  
Shipment, stocking and storage services

### The Broadest Range of Automation Components

With a comprehensive line of more than 30,000 automation components, Festo is capable of solving the most complex automation requirements.



**Electromechanical**  
Electromechanical actuators, motors, controllers & drivers



**Pneumatics**  
Pneumatic linear and rotary actuators, valves, and air supply



**PLCs and I/O Devices**  
PLC's, operator interfaces, sensors and I/O devices

### Supporting Advanced Automation... As No One Else Can!

Festo is a leading global manufacturer of pneumatic and electromechanical systems, components and controls for industrial automation, with more than 16,000 employees in 60 national headquarters serving more than 180 countries. For more than 80 years, Festo has continuously elevated the state of manufacturing with innovations and optimized motion control solutions that deliver higher performing, more profitable automated manufacturing and processing equipment. Our dedication to the advancement of automation extends beyond technology to the education and development of current and future automation and robotics designers with simulation tools, teaching programs, and on-site services.

### Quality Assurance, ISO 9001 and ISO 14001 Certifications

Festo Corporation is committed to supply all Festo products and services that will meet or exceed our customers' requirements in product quality, delivery, customer service and satisfaction.

To meet this commitment, we strive to ensure a consistent, integrated, and systematic approach to management that will meet or exceed the requirements of the ISO 9001 standard for Quality Management and the ISO 14001 standard for Environmental Management.



© Copyright 2013, Festo Corporation. While every effort is made to ensure that all dimensions and specifications are correct, Festo cannot guarantee that publications are completely free of any error, in particular typing or printing errors. Accordingly, Festo cannot be held responsible for the same. For Liability and Warranty conditions, refer to our "Terms and Conditions of Sale", available from your local Festo office. All rights reserved. No part of this publication may be reproduced, distributed, or transmitted in any form or by any means, electronic, mechanical, photocopying or otherwise, without the prior written permission of Festo. All technical data subject to change according to technical update.



Printed on recycled paper at New Horizon Graphic, Inc., FSC certified as an environmental friendly printing plant.

# Festo North America

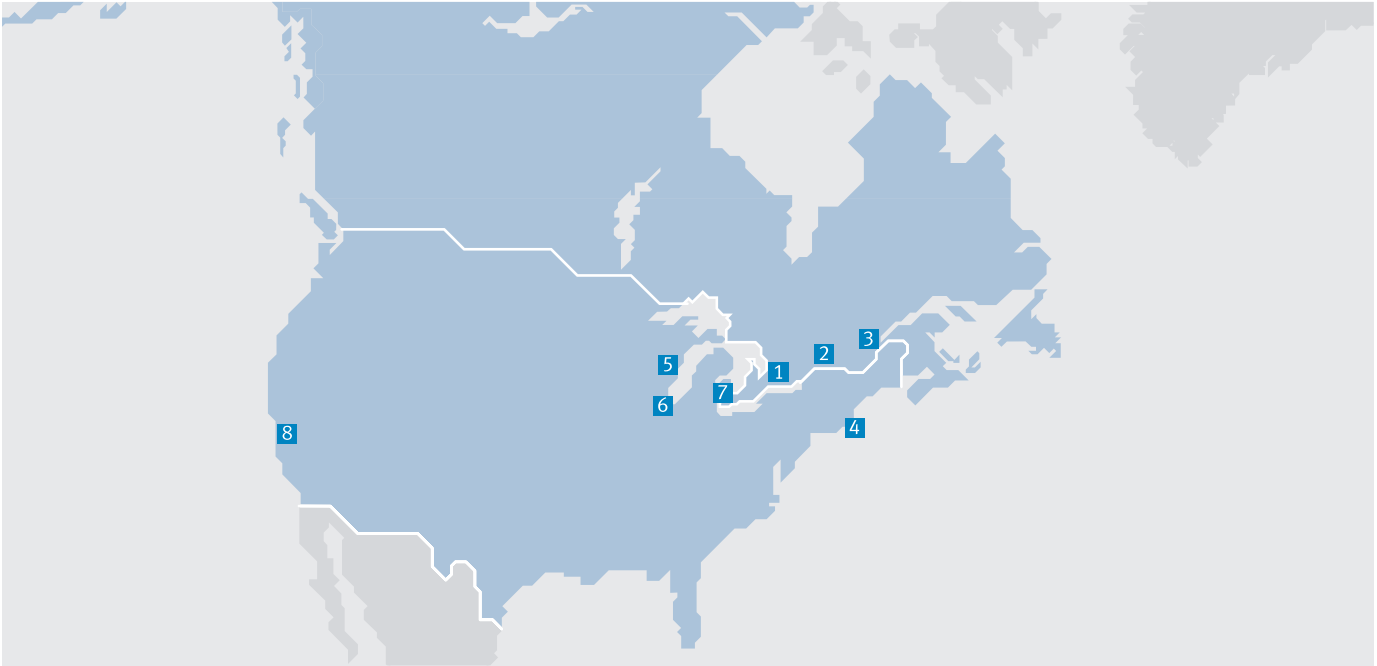

**1 Festo Canada  
Headquarters  
Festo Inc.**  
5300 Explorer Drive  
Mississauga, ON  
L4W 5G4

**2 Montréal**  
5600, Trans-Canada  
Pointe-Claire, QC  
H9R 1B6

**3 Québec City**  
2930, rue Watt#117  
Québec, QC  
G1X 4G3



**4 Festo United States  
Headquarters  
Festo Corporation**  
395 Moreland Road  
Hauppauge, NY  
11788

**5 Appleton**  
North 922 Tower View Drive, Suite N  
Greenville, WI  
54942

**7 Detroit**  
1441 West Long Lake Road  
Troy, MI  
48098

**6 Chicago**  
85 W Algonquin - Suite 340  
Arlington Heights, IL  
60005

**8 Silicon Valley**  
4935 Southfront Road, Suite F  
Livermore, CA  
94550

## Festo Regional Contact Center

### Canadian Customers

Commercial Support:  
Tel: 1 877 GO FESTO (1 877 463 3786)  
Fax: 1 877 FX FESTO (1 877 393 3786)  
Email: festo.canada@ca.festo.com

Technical Support:  
Tel: 1 866 GO FESTO (1 866 463 3786)  
Fax: 1 877 FX FESTO (1 877 393 3786)  
Email: technical.support@ca.festo.com

### USA Customers

Commercial Support:  
Tel: 1 800 99 FESTO (1 800 993 3786)  
Fax: 1 800 96 FESTO (1 800 963 3786)  
Email: customer.service@us.festo.com

Technical Support:  
Tel: 1 866 GO FESTO (1 866 463 3786)  
Fax: 1 800 96 FESTO (1 800 963 3786)  
Email: product.support@us.festo.com