

Toothed belt axes ELGG

FESTO



Toothed belt axes ELGG

Key features



At a glance

- Toothed belt axis with two opposing slides
- Optimum price/performance ratio
- Ready-to-install unit for quick and easy design
- High reliability thanks to a tested service life of 2500 km per slide
- Motor can be mounted on four sides using identical mounting accessories
- Complete kit for a simple and space-saving solution for end-position sensing
- Plain-bearing guide
 - For small loads
 - Restricted operating behaviour with torque load
 - Guide backlash = 0.05 mm (on delivery)
- Recirculating ball bearing guide
 - For medium loads
 - Very good operating behaviour with torque load
 - Backlash-free guide (preloaded guide elements)

Opposing movement, controlled via a motor

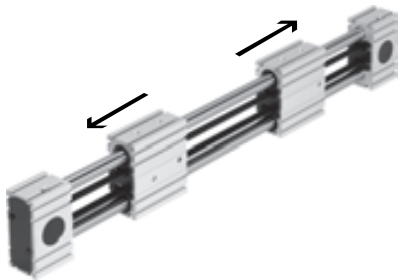

Optionally with central support to increase the forces and torques per slide

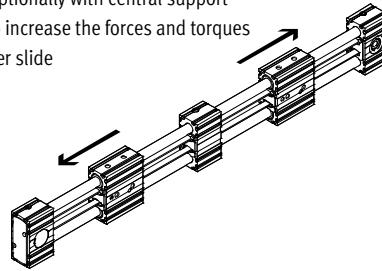

Application examples

- Suitable for sorting, separating and spreading
- For opening doors
- For gripping tasks with small loads
- Positioning and handling with low process forces
- Centring and aligning

Characteristic values of the axes

The specifications shown in the table are maximum values.

The precise values for each of the variants can be found in the relevant technical data.

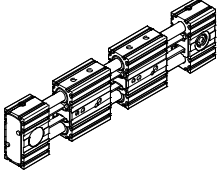
Version	Size	Working stroke per slide [mm]	Speed [m/s]	Repetition accuracy [mm]	Feed force ¹⁾ [N]	Guide characteristics				
						Forces and torques				
						Fy [N]	Fz [N]	Mx [Nm]	My [Nm]	Mz [Nm]
	35	50 ... 700	3	±0.1	50	50	50	2.5	20	20
	45	50 ... 900	3	±0.1	100	100	100	5	40	40
	55	50 ... 1200	3	±0.1	350	300	300	15	124	124

1) Combined feed force of both slides

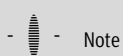

Note

PositioningDrives
sizing software
www.festo.com

Toothed belt axes ELGG

Key features

Complete system comprising toothed belt axis, motor, motor controller and motor mounting kit

Toothed belt axis with recirculating ball bearing guide or plain-bearing guide

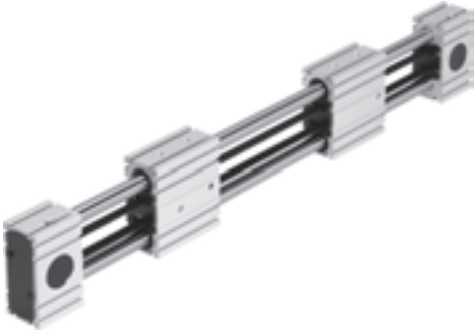

Motor

→ 18



- 1 Servo motor EMME-AS, EMMS-AS
- 2 Stepper motor EMMS-ST

-  - Note

A range of specially adapted complete solutions is available for the toothed belt axis ELGG and the motors.

Motor controller

Technical data → Internet: motor controller



- 1 Servo motor controller CMMP-AS
- 2 Stepper motor controller CMMS-ST

Motor mounting kit

→ 18

Axial kit



Kit comprising:

- Motor flange
- Coupling housing
- Coupling
- Screws
- Slot nuts

Toothed belt axes ELGG

Peripherals overview

FESTO

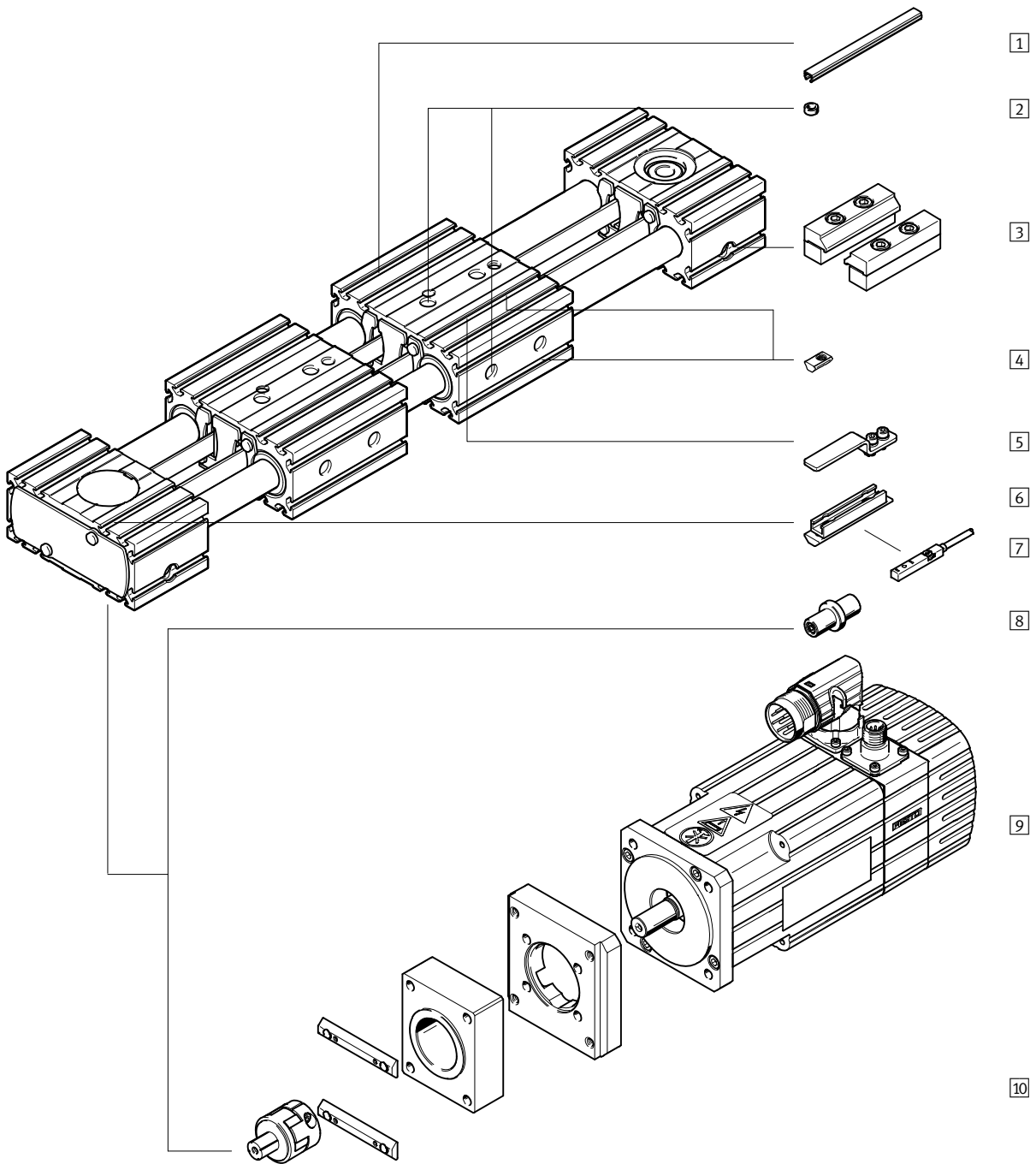

Toothed belt axes ELGG

Peripherals overview

Variants and accessories		
Type	Description	→ Page/Internet
1 Slot cover NC	<ul style="list-style-type: none"> For protecting against ingress of dirt 	22
2 Centring sleeve ZBH	<ul style="list-style-type: none"> For centring loads and attachments on the slide 4 centring sleeves included in the scope of delivery of the axis 	22
3 Profile mounting MA	For mounting the axis on the bearing cap	21
4 Slot nut NM	For mounting attachments	22
5 Switching lug SA, SB	For sensing the slide position	21
6 Sensor bracket SA, SB	Adapter for mounting the inductive proximity sensors on the axis	21
7 Proximity sensor, T-slot SA, SB	<ul style="list-style-type: none"> Inductive proximity sensor, for T-slot 1 switching lug and 1 sensor bracket are included in the scope of delivery with the order code SA, SB 	23
8 Drive shaft EA	<ul style="list-style-type: none"> Can, if required, be used as an alternative interface No drive shaft is required for the axis/motor combination → 18 	22
9 Motor EMME, EMMS	Motors specially matched to the axis, with or without brake	18
10 Axial kit EAMM	For axial motor mounting (comprising: coupling, coupling housing and motor flange)	18
– Connecting cable NEBU	For proximity sensor (order code SA and SB)	23

Toothed belt axes ELGG

Type codes

ELGG - TB - - 45 - 500 - 30H - L - - M

Type	
ELGG	Linear axis
Drive function	
TB	Toothed belt
Guide	
-	Recirculating ball bearing guide
GF	Plain-bearing guide
Size	
Stroke per slide [mm]	
Stroke reserve per slide	
Slide	
-	Standard slide
L	Long slide
Additional slide	
-	No additional slide
ZB	1 slide on right, 1 slide on left
Additional function	
-	None
M	Central support

Toothed belt axes ELGG

Type codes



→	+	2SA		4NM	EA	2MA
Proximity sensor						
...SA	Proximity sensor (SIES), inductive, T-slot, PNP, N/O contact, cable 7.5 m					
...SB	Proximity sensor (SIES), inductive, T-slot, PNP, N/C contact, cable 7.5 m					
Cover						
...NC	For mounting slot					
Slot nut						
...NM	For mounting slot					
Drive shaft						
...EA	Drive shaft					
Profile mounting						
...MA	Profile mounting					

Toothed belt axes ELGG

Technical data

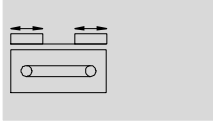
Function



-  Size
35 ... 55
-  Stroke length
50 ... 1200 mm
-  www.festo.com

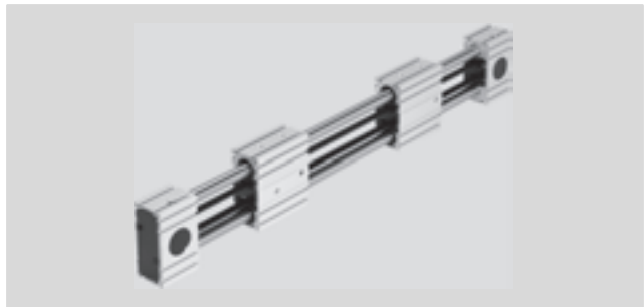

General technical data				
Size		35	45	55
Design		Electromechanical linear axis with toothed belt		
Guide		Recirculating ball bearing guide		
		Plain-bearing guide		
Mounting position		Any		
Working stroke per slide	[mm]	50 ... 700	50 ... 900	50 ... 1200
Max. feed force $F_x^{1)}$	[N]	50	100	350
Max. no-load torque	[Nm]	0.18	0.3	0.5
Max. driving torque	[Nm]	0.46	1.24	5
Max. no-load resistance to shifting	[N]	10.8	16.1	27.9
Max. speed				
Recirculating ball bearing guide	[m/s]	3		
Plain-bearing guide	[m/s]	1		
Max. acceleration ²⁾	[m/s ²]	50		
Repetition accuracy	[mm]	±0.1		

- 1) Combined feed force of both slides
- 2) The max. acceleration is dependent on the moving load, the driving torque and the max. feed force

Operating and environmental conditions		
Ambient temperature		
Recirculating ball bearing guide	[°C]	-10 ... +50
Plain-bearing guide	[°C]	0 ... +40
Protection class		IP20
Duty cycle	[%]	100

Weight [kg]				
Size		35	45	55
Recirculating ball bearing guide				
Basic weight with 0 mm stroke ¹⁾				
Standard slide		1.9	4.2	7.2
Long slide		2.6	6.0	10.3
Additional weight per 1,000 mm stroke		4.9	10.0	15.6
Moving load		0.8	1.7	2.9
Slide				
Standard slide		0.8	1.7	2.9
Long slide		1.3	3.0	5.2
Additional slide		0.6	1.5	2.6
Central support		0.2	0.5	0.7

- 1) Incl. 2 slides, without central support

Toothed belt axes ELGG

Technical data

FESTO

Weight [kg]			
Size	35	45	55
Plain-bearing guide			
Basic weight with 0 mm stroke ¹⁾			
Standard slide	1.9	4.3	7.2
Long slide	2.7	6.2	10.8
Additional weight per 1,000 mm stroke	4.9	10.0	15.6
Moving load	0.8	1.7	3.0
Slide			
Standard slide	0.8	1.7	3.0
Long slide	1.5	3.2	5.6
Additional slide	0.6	1.5	2.6
Central support	0.2	0.5	0.7

1) Incl. 2 slides, without central support

Toothed belt			
Size	35	45	55
Pitch [mm]	2	3	3
Expansion [%]	0.094	0.08	0.21
Width [mm]	10	15	19.3
Effective diameter [mm]	18.46	24.83	28.65
Feed constant [mm/rev.]	58	78	90

Mass moment of inertia			
Size	35	45	55
J ₀			
Standard slide [kg mm ²]	76.12	289.55	656.98
Long slide [kg mm ²]	128.6	522.01	1212.78
J _S per metre stroke [kg mm ² /m]	0.26	1.1	1.9
J _L per kg effective load [kg mm ² /kg]	85	154	205
J _W Additional slide [kg mm ²]	55	224	533

The mass moment of inertia J_A of the entire axis is calculated as follows:

$$J_A = J_0 + K \times J_W + J_S \times \text{working stroke [m]} + J_L \times \text{m effective load [kg]}$$

K = Number of additional slides

Materials

Sectional view

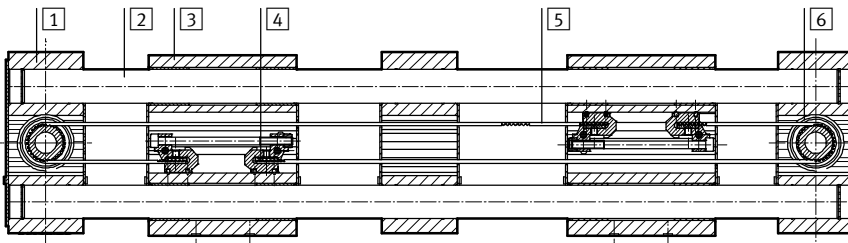

Axis		
1	Bearing cap, profile	Anodised wrought aluminium alloy
2	Guide rods	Tempered steel, hardened and hard-chromium plated
3	Slide, profile	Anodised wrought aluminium alloy
4	Toothed belt clamping component	Beryllium bronze
5	Toothed belt	Polychloroprene with glass cord and nylon coating
6	Pulley	High-alloy stainless steel
Note on materials		RoHS-compliant
		Contains PWIS (paint-wetting impairment substances)

Toothed belt axes ELGG

Technical data

Characteristic load values

The indicated forces and torques refer to the centre of the guide. These values must not be exceeded during dynamic operation. Special attention must be paid to the cushioning phase.

Without central support

The point of application of force is the point where the centre of the guide and the centre point between the two bearing caps intersect.

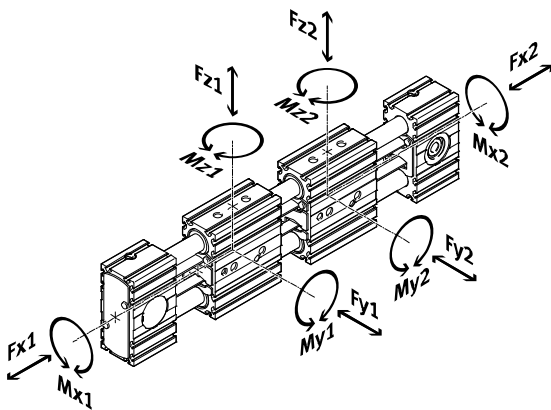

If the axis is subjected to more than two of the indicated forces and torques simultaneously, the following equation must be satisfied in addition to the indicated maximum loads:

With central support

The point of application of force is the point where the centre of the guide and the centre point between the bearing cap and the central support intersect.

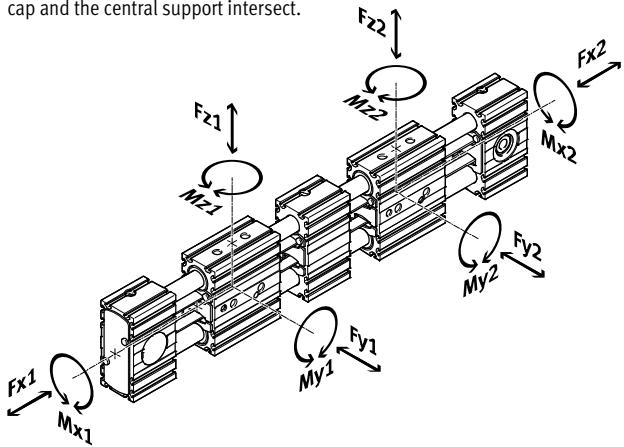

Without central support

Calculating the load comparison factor:

$$f_v = \frac{|F_{y1,dyn} + F_{y2,dyn}|}{F_{Ymax.}} + \frac{|F_{z1,dyn} + F_{z2,dyn}|}{F_{Zmax.}} + \frac{|M_{x1,dyn} + M_{x2,dyn}|}{M_{Xmax.}} + \frac{|M_{y1,dyn} + M_{y2,dyn}|}{M_{Ymax.}} + \frac{|M_{z1,dyn} + M_{z2,dyn}|}{M_{Zmax.}} \leq 1$$

With central support

Calculating the load comparison factor:

$$f_v = \frac{|F_{y1,dyn}|}{F_{Ymax.}} + \frac{|F_{z1,dyn}|}{F_{Zmax.}} + \frac{|M_{x1,dyn}|}{M_{Xmax.}} + \frac{|M_{y1,dyn}|}{M_{Ymax.}} + \frac{|M_{z1,dyn}|}{M_{Zmax.}} \leq 1$$

$$f_v = \frac{|F_{y2,dyn}|}{F_{Ymax.}} + \frac{|F_{z2,dyn}|}{F_{Zmax.}} + \frac{|M_{x2,dyn}|}{M_{Xmax.}} + \frac{|M_{y2,dyn}|}{M_{Ymax.}} + \frac{|M_{z2,dyn}|}{M_{Zmax.}} \leq 1$$

Permissible forces and torques for a service life of 2500 km per slide						
Guide	Plain-bearing guide			Recirculating ball bearing guide		
Size	35	45	55	35	45	55
F _{ymax.} , F _{zmax.} [N]	50	100	300	50	100	300
Standard slide						
M _{xmax.} [Nm]	1	2.5	5	2.5	5	15
M _{ymax.} [Nm]	4	8	16	8	16	48
M _{zmax.} [Nm]	4	8	16	8	16	48
Long slide						
M _{xmax.} [Nm]	1	2.5	5	2.5	5	15
M _{ymax.} [Nm]	10	20	40	20	40	124
M _{zmax.} [Nm]	10	20	40	20	40	124

Toothed belt axes ELGG

Technical data

Service life

The service life of the guide depends on the load. To provide a rough indication of the service life of the guide,

the graph below plots the load comparison factor f_v against the service life.

These values are only theoretical. Consultation with your local contact person at Festo is mandatory for load

comparison factors f_v greater than 1.5.

Load comparison factor f_v as a function of service life

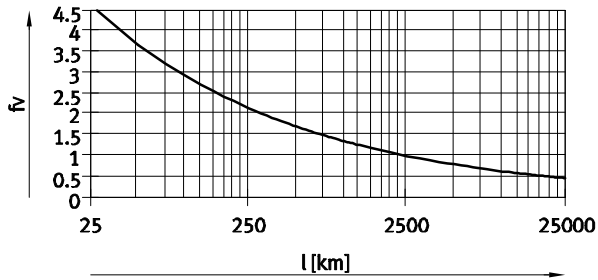

Example:

A user wants to move an X kg load. Using the formula $\rightarrow 10$ gives a value of 1.5 for the load comparison factor f_v . According to the graph, the guide would have a service life of

approx. 750 km. Reducing the acceleration reduces the M_z and M_y values. A load comparison factor of 1 now gives a service life of 2500 km.

Note
PositioningDrives
sizing software
www.festo.com

Maximum acceleration a as a function of applied load m

ELGG-35

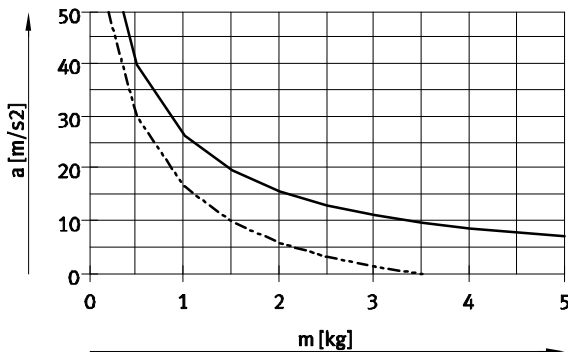

ELGG-45

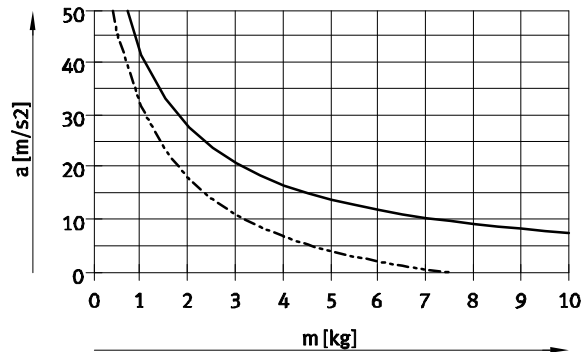

ELGG-55

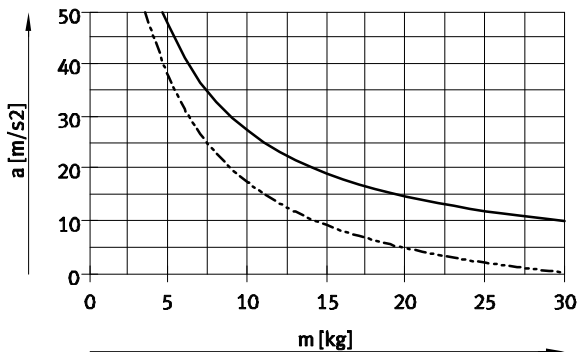

Note

For the plain-bearing guide (GF) it is recommended to reduce the acceleration to minimise overshings and increase positioning accuracy.

— Horizontal
- - - Vertical

Toothed belt axes ELGG

Technical data

Feed force F_x as a function of input torque M

ELGG-35

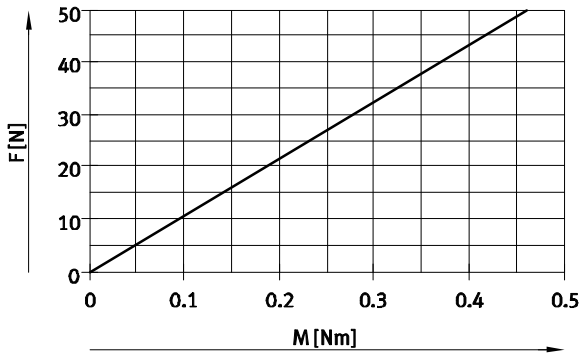

ELGG-45

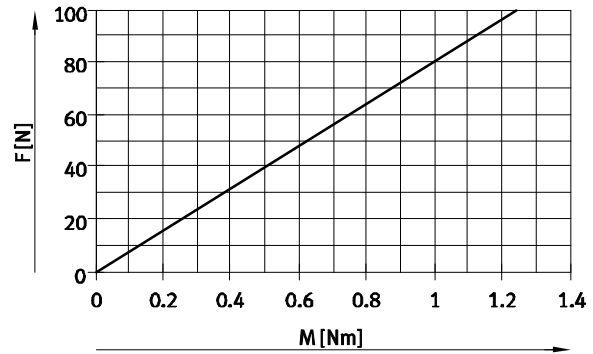

ELGG-55

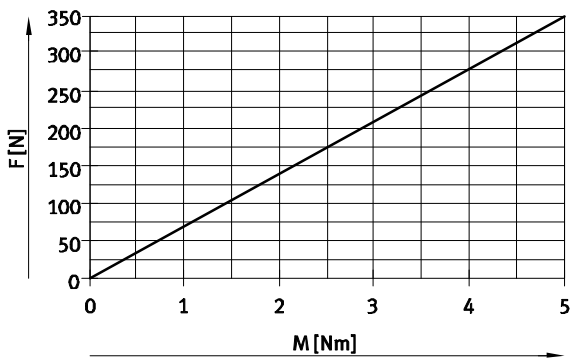

Speed v as a function of rotational speed n

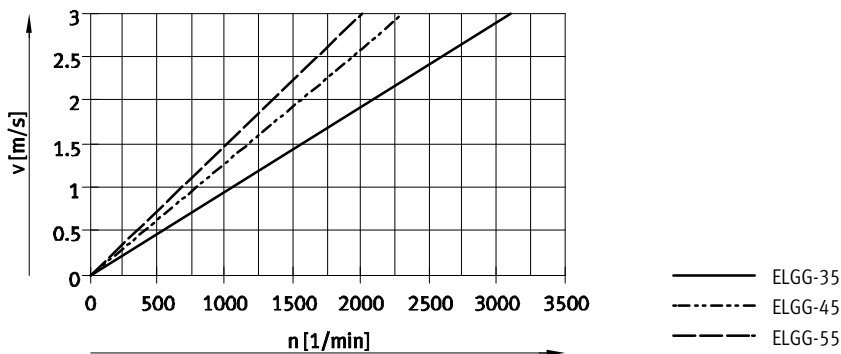

Min. nominal stroke

With standard slide or long slide L with additional slide ZB

Size	35		45		55	
Variant	-/L	ZB	-/L	ZB	-/L	ZB
Min. nominal stroke [mm]	50	126	50	146	50	166

Toothed belt axes ELGG

Technical data

Stroke reserve

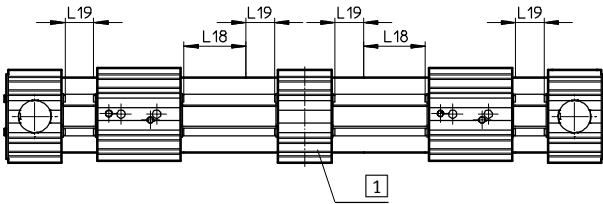

- L18 = Nominal stroke
- L19 = Stroke reserve
- 1 Central support

- The stroke reserve is a safety distance available on both sides of the slide in addition to the nominal stroke
- The sum of the nominal stroke and 2x stroke reserve must not exceed the maximum working stroke per slide
- The stroke reserve length can be freely selected
- The stroke reserve is defined via the “stroke reserve” attribute in the modular product system

Example:
 Type ELGG-TB-45-500-20H-...
 Nominal stroke = 500 mm
 2x stroke reserve = 40 mm
 Working stroke per slide = 540 mm
 (540 mm = 500 mm + 2x 20 mm)

Working stroke reduction

With standard slide or long slide L with additional slide ZB

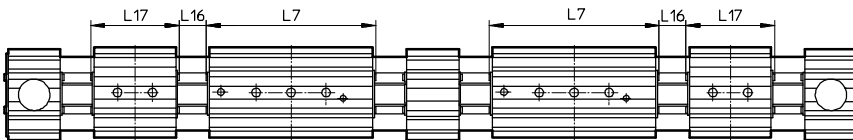

- L7 = Slide length
- L16 = Distance between both slides
- L17 = Additional slide length

- With a toothed belt axis with additional slide, the working stroke is reduced by the length of the additional slide and the distance between both slides
 - If the variant long slide L is ordered, the additional slide is not extended
- Example:**
 Type ELGG-TB-35-500-...-ZR
 Working stroke = 500 mm
 L16 = 10 mm
 L7 = 146 mm
 L17 = 76 mm

Working stroke per slide with additional slide = 414 mm
 (500 mm – 10 mm – 76 mm)

Dimensions – Additional slide

Size	35	45	55
Length L17 [mm]	76	96	116
Distance between the slides L16 [mm]	≥ 0		

2nd moment of area

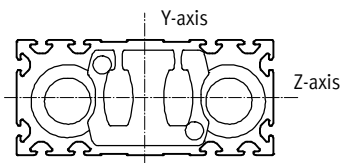

Size	35	45	55
ly [mm ⁴]	3.77x10 ³	1.57x10 ⁴	3.83x10 ⁴
lz [mm ⁴]	1.89x10 ⁵	8.08x10 ⁵	1.85x10 ⁶

Recommended deflection limits

It is recommended to adhere to a maximum deflection of 0.5 mm so as not to impair the functionality of the axes. Greater deformation can result in increased friction, greater wear and reduced service life.

Toothed belt axes ELGG

Technical data

FESTO

Dimensions

Download CAD data → www.festo.com

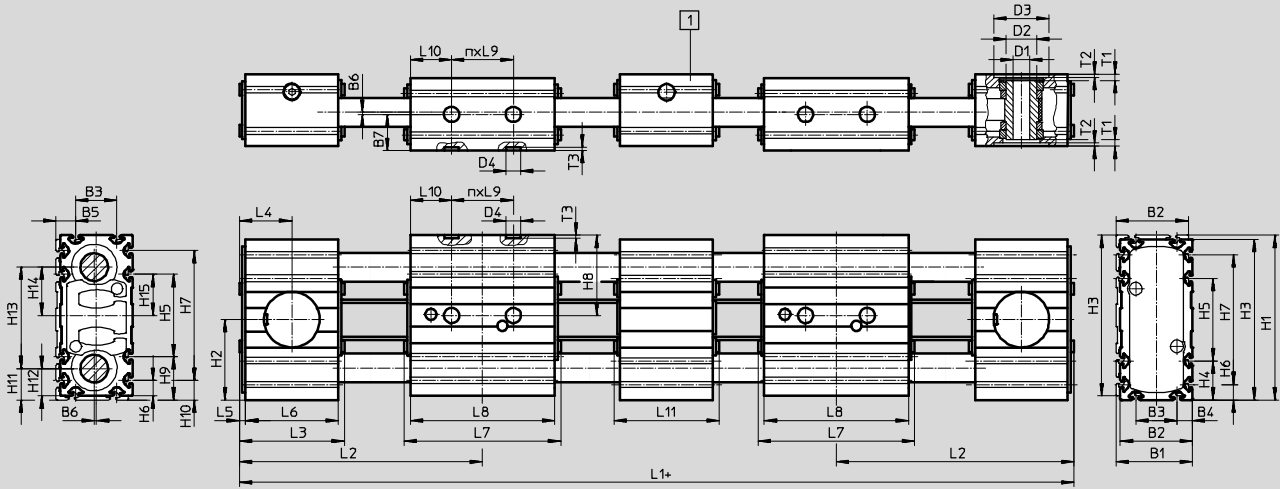

- - Note

With the size 35 and stroke > 350 mm,
size 45 and stroke > 450 mm,
size 55 and stroke > 700 mm,
the toothed belt axis is always supplied with
central support M.

+ Plus 2x stroke + 4x stroke reserve + L11

1 Central support

Profile

ELGG-35

ELGG-45

ELGG-55

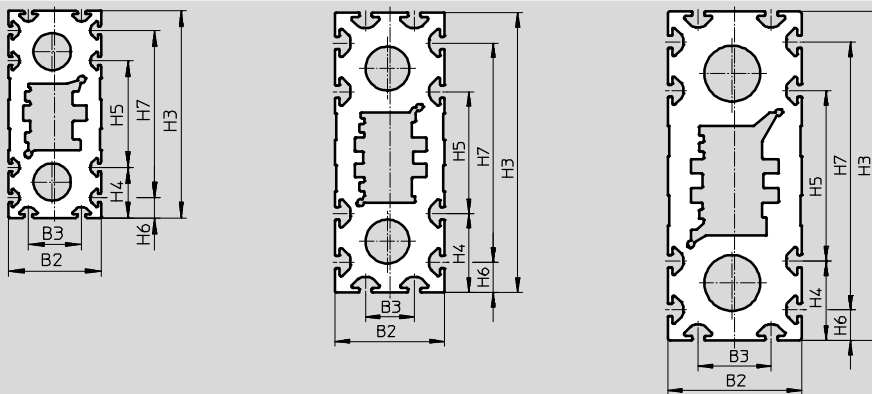

Toothed belt axes ELGG

Technical data

Size	B1	B2	B3	B4	B5	B6	B7	D1 ∅ H7	D2 ∅	D3 ∅ H7	D4 ∅ H7	H1	H2	H3
ELGG-35	37	35	20	7.5	9.5	1	17.5	8	15	27	7	80	39	78
ELGG-35-L														
ELGG-45	47	45	20	12.5	14.5		22.5	10	20	38		117	57.5	115
ELGG-45-L														
ELGG-55	57	55	30	12.5	14.5		27.5	16	25	48		137	67.5	135
ELGG-55-L														

Size	H4	H5	H6	H7	H8	H9	H10	H11	H12	H13	H14	H15	L1	L2
ELGG-35	19	40	7.5	63	39	21	9.5	15.5	13.5	49	23.5	20	259	89
ELGG-35-L													399	124
ELGG-45	32.5	50	12.5	90	57.5	34.5	14.5	23	21	71	34.5	25	317	108
ELGG-45-L													497	153
ELGG-55	32.5	70	12.5	110	67.5	34.5	14.5	25.5	23.5	86	42	35	361	120
ELGG-55-L													581	175

Size	L3	L4	L5	L6	L7	L8	L9	L10	L11	n	T1	T2	T3 +0.1
ELGG-35	51	25.5	3	45	76	70	30	20	51	1	3.1	1.6	1.6
ELGG-35-L					146	140		40		2			
ELGG-45	60	30		54	96	90	40	25	60	1	3	1.7	
ELGG-45-L					186	180		50		2			
ELGG-55	62	31		56	116	110	40	35	62	1	4.5	2	
ELGG-55-L					226	220		70		2			

Toothed belt axes ELGG

Ordering data – Modular products



Order code

Axis

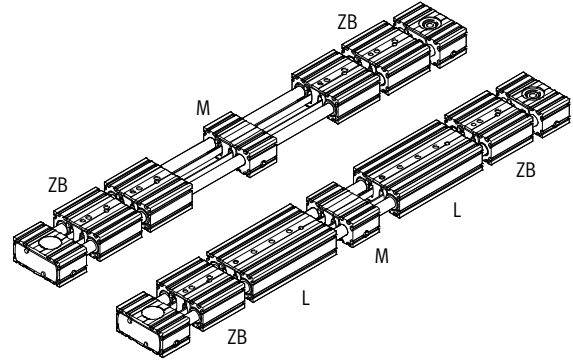
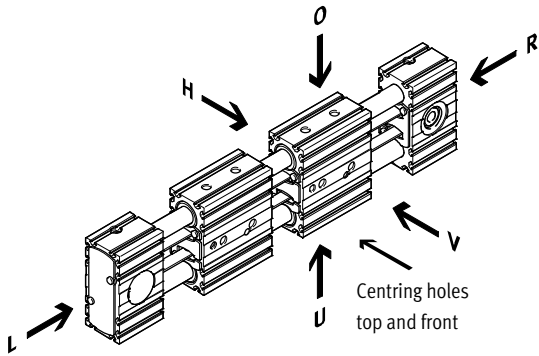

O top
U underneath
R right
L left
V front
H rear

L Long slide
ZB Additional slide
M Central support

Accessories

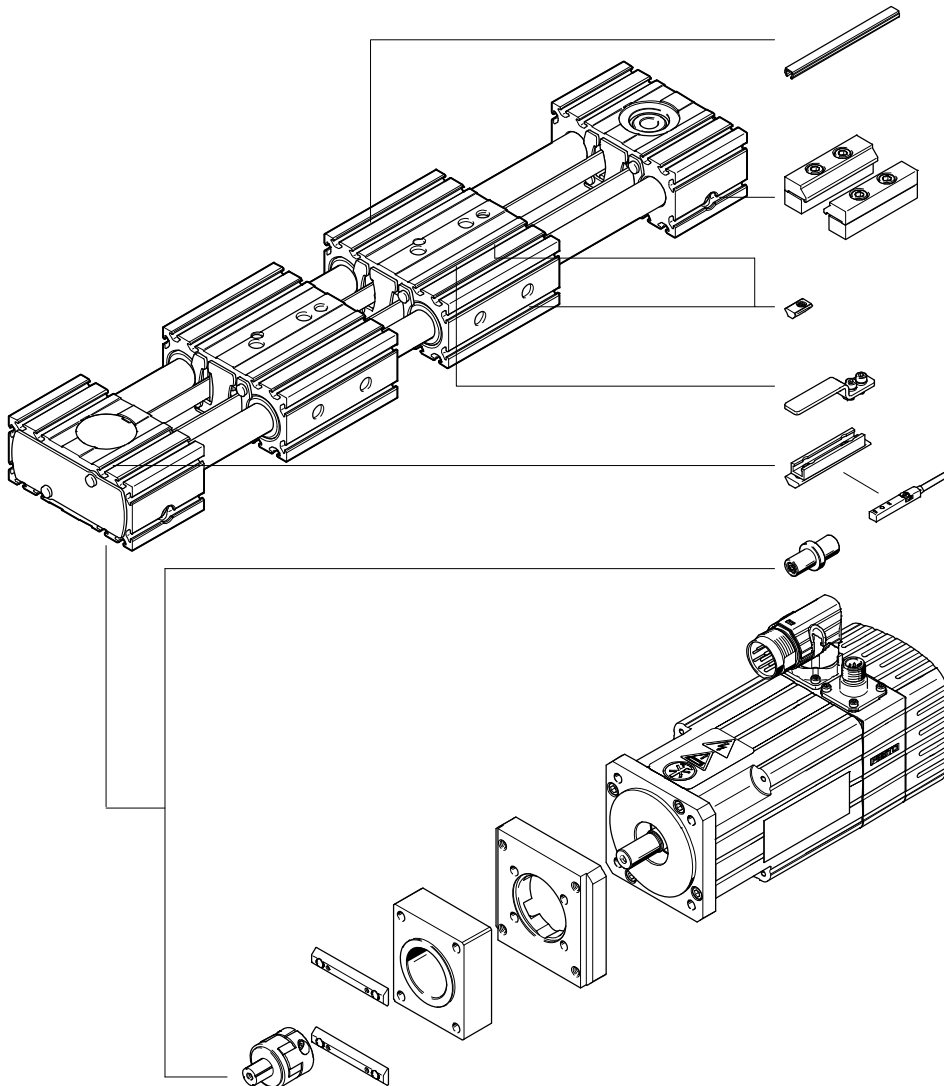

NC

MA

NM

SA, SB

SA, SB

EA

Servo motor
Stepper motor
→ 18

Axial kit
→ 18

Toothed belt axes ELGG

Ordering data – Modular products



Ordering table									
Size	35		45		55		Condi- tions	Code	Enter code
M Module no.	571058		571059		571060				
Design	Linear axis							ELGG	ELGG
Function	Toothed belt							-TB	-TB
O Guide	Recirculating ball bearing guide								
	Plain-bearing guide							-GF	
M Size [mm]	35		45		55			-...	-...
Stroke length per slide [mm]	1 ... 700		1 ... 900		1 ... 1200			-...	-...
Stroke reserve per slide	0 ... 999 (0 = no stroke reserve)						1	-...H	
O Slide design	Standard slide								
	Long slide							-L	
Additional slide	No additional slide								
	1 slide on right, 1 slide on left						2	-ZB	
Additional function	None								
	Central support						3	-M	
Accessories	Accessories enclosed separately							+	+
Proximity sensor (SIES), inductive, T-slot, PNP, incl. switching lug	N/O contact, cable 7.5 m	1 ... 6						...SA	
	N/C contact, cable 7.5 m	1 ... 6						...SB	
Mounting slot cover	-	1 ... 50 (1 = 2 units, 500 mm)						...NC	
Slot nut for mounting slot	1 ... 99								...NM
Drive shaft	1 ... 4								...EA
Profile mounting	1 ... 2								...MA

1 The sum of the nominal stroke and 2x stroke reserve must be at least 50 mm and must not exceed the maximum stroke length.

3 M With the size 35 and stroke > 350 mm, size 45 and stroke > 450 mm, size 55 and stroke > 700 mm, the toothed belt axis is always supplied with central support M.

2 ZB Working stroke reduction → 13





Size	35		45		55	
Variant	-/L	ZB	-/L	ZB	-/L	ZB
Min. nominal stroke [mm]	50	126	50	146	50	166

Transfer order code

Toothed belt axes ELGG

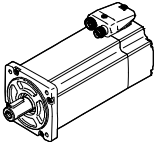
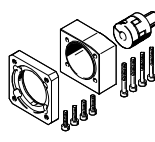
Accessories

 Note
Depending on the combination of motor and drive, it may not be possible to reach the maximum feed force of the drive.





Permissible axis/motor combinations with axial kit – Without gear unit					Technical data → Internet: eamm-a
Motor ¹⁾	Axial kit	Axial kit comprises:			
		Motor flange	Coupling	Coupling housing	
					
Type	Part No. Type	Part No. Type	Part No. Type	Part No. Type	
ELGG-35					
With servo motor					
EMMS-AS-55-...	1133400 EAMM-A-R27-55A	558176 EAMF-A-38A-55A	557999 EAMD-19-15-9-8X10	1133397 EAMK-A-R27-38A	
With stepper motor					
EMMS-ST-57-...	1133403 EAMM-A-R27-57A	560692 EAMF-A-38A-57A	561292 EAMD-16-15-6.35-8X10	1133397 EAMK-A-R27-38A	
With integrated drive					
EMCA-EC-67-...	1456619 EAMM-A-R27-67A	1490100 EAMF-A-38A-67A	557999 EAMD-19-15-9-8X10	1133397 EAMK-A-R27-38A	
ELGG-45					
With servo motor					
EMME-AS-60-...	2224996 EAMM-A-R38-60P	1987412 EAMF-A-38A-60P	1453861 EAMD-28-22-14-10X12	1133398 EAMK-A-R38-38A	
EMMS-AS-70-...	1133401 EAMM-A-R38-70A	558018 EAMF-A-38A-70A	558000 EAMD-25-22-11-10X12	1133398 EAMK-A-R38-38A	
With stepper motor					
EMMS-ST-57-...	1578138 EAMM-A-R38-57A	560692 EAMF-A-38A-57A	561293 EAMD-25-22-6.35-10X12	1133398 EAMK-A-R38-38A	
EMMS-ST-87-...	1133404 EAMM-A-R38-87A	560693 EAMF-A-38A-87A	558000 EAMD-25-22-11-10X12	1133398 EAMK-A-R38-38A	
ELGG-55					
With servo motor					
EMMS-AS-70-...	1578139 EAMM-A-R48-70A	558025 EAMF-A-48A-70A	558001 EAMD-32-32-11-16X20	1133399 EAMK-A-R48-48A	
EMME-AS-80-...	2225090 EAMM-A-R48-80P	2043427 EAMF-A-48A-80P	558002 EAMD-42-40-19-16X25	1133399 EAMK-A-R48-48A	
EMMS-AS-100-...	1133402 EAMM-A-R48-100A	558020 EAMF-A-48A-100A	558002 EAMD-42-40-19-16X25	1133399 EAMK-A-R-48-48A	
With stepper motor					
EMMS-ST-87-...	1133405 EAMM-A-R48-87A	560695 EAMF-A-48A-87A	558001 EAMD-32-32-11-16X20	1133399 EAMK-A-R48-48A	

1) The input torque must not exceed the maximum permissible transferable torque of the axial kit.

Toothed belt axes ELGG

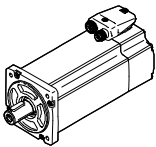
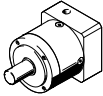
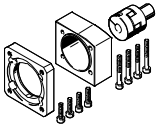
Accessories

FESTO

Permissible axis/motor combinations with axial kit – With gear unit						Technical data → Internet: eamm-a
Motor ¹⁾	Gear unit	Axial kit	Axial kit comprises:			
			Motor flange	Coupling	Coupling housing	
						
Type		Part No. Type	Part No. Type	Part No. Type	Part No. Type	
ELGG-35						
With servo motor						
EMME-AS-40-...	EMGA-40-P-G...-EAS-40	1456622 EAMM-A-R27-40G	1460097 EAMF-A-38A-40G	557998 EAMD-19-15-10-8X10	1133397 EAMK-A-R27-38A	
EMMS-AS-40-...	EMGA-40-P-G...-SAS-40	1456622 EAMM-A-R27-40G	1460097 EAMF-A-38A-40G	557998 EAMD-19-15-10-8X10	1133397 EAMK-A-R27-38A	
With stepper motor						
EMMS-ST-42-...	EMGA-40-P-G...-SST-42	1456622 EAMM-A-R27-40G	1460097 EAMF-A-38A-40G	557998 EAMD-19-15-10-8X10	1133397 EAMK-A-R27-38A	
With integrated drive						
EMCA-EC-67-...	EMGC-40-...	1456622 EAMM-A-R27-40G	1460097 EAMF-A-38A-40G	557998 EAMD-19-15-10-8X10	1133397 EAMK-A-R27-38A	
ELGG-45						
With servo motor						
EMME-AS-40-...	EMGA-40-P-G...-EAS-40	1456623 EAMM-A-R38-40G	1460097 EAMF-A-38A-40G	1453860 EAMD-25-22-10-10X12	1133398 EAMK-A-R38-38A	
EMMS-AS-40-...	EMGA-40-P-G...-SAS-40	1456623 EAMM-A-R38-40G	1460097 EAMF-A-38A-40G	1453860 EAMD-25-22-10-10X12	1133398 EAMK-A-R38-38A	
EMMS-AS-55-...	EMGA-60-P-G...-SAS-55	2310075 EAMM-A-R38-60G	558017 EAMF-A-38A-60G/H	558000 EAMD-25-22-11-10X12	1133398 EAMK-A-R38-38A	
EMME-AS-60-...	EMGA-60-P-G...-EAS-60	1456630 EAMM-A-R38-60H	558017 EAMF-A-38A-60G/H	1453861 EAMD-28-22-14-10X12	1133398 EAMK-A-R38-38A	
EMMS-AS-70-...	EMGA-60-P-G...-SAS-70	2310075 EAMM-A-R38-60G	558017 EAMF-A-38A-60G/H	558000 EAMD-25-22-11-10X12	1133398 EAMK-A-R38-38A	
With stepper motor						
EMMS-ST-42-...	EMGA-40-P-G...-SST-42	1456623 EAMM-A-R38-40G	1460097 EAMF-A-38A-40G	1453860 EAMD-25-22-10-10X12	1133398 EAMK-A-R38-38A	
EMMS-ST-57-...	EMGA-60-P-G...-SST-57	2310075 EAMM-A-R38-60G	558017 EAMF-A-38A-60G/H	558000 EAMD-25-22-11-10X12	1133398 EAMK-A-R38-38A	
With integrated drive						
EMCA-EC-67-...	EMGC-40-...	1456623 EAMM-A-R38-40G	1460097 EAMF-A-38A-40G	1453860 EAMD-25-22-10-10X12	1133398 EAMK-A-R38-38A	
	EMGC-60-...	1456630 EAMM-A-R38-60H	558017 EAMF-A-38A-60G/H	1453861 EAMD-28-22-14-10X12	1133398 EAMK-A-R38-38A	

1) The input torque must not exceed the maximum permissible transferable torque of the axial kit.

Toothed belt axes ELGG

Accessories

FESTO

Permissible axis/motor combinations with axial kit – With gear unit						Technical data → Internet: eamm-a
Motor ¹⁾	Gear unit	Axial kit	Axial kit comprises:			
			Motor flange	Coupling	Coupling housing	
Type		Part No. Type	Part No. Type	Part No. Type	Part No. Type	
ELGG-55						
With servo motor						
EMMS-AS-55-...	EMGA-60-P-G...-SAS-55	2374780 EAMM-A-R48-60G	558019 EAMF-A-48A-60G/H	558001 EAMD-32-32-11-16X20	1133399 EAMK-A-R48-48A	
EMME-AS-60-...	EMGA-60-P-G...-EAS-60	1456633 EAMM-A-R48-60H	558019 EAMF-A-48A-60G/H	1377840 EAMD-32-32-14-16X20	1133399 EAMK-A-R48-48A	
EMMS-AS-70-...	EMGA-60-P-G...-SAS-70	2374780 EAMM-A-R48-60G	558019 EAMF-A-48A-60G/H	558001 EAMD-32-32-11-16X20	1133399 EAMK-A-R48-48A	
With stepper motor						
EMMS-ST-57-...	EMGA-60-P-G...-SST-57	2374780 EAMM-A-R48-60G	558019 EAMF-A-48A-60G/H	558001 EAMD-32-32-11-16X20	1133399 EAMK-A-R48-48A	
With integrated drive						
EMCA-EC-67-...	EMGC-60-...	1456633 EAMM-A-R48-60H	558019 EAMF-A-48A-60G/H	1377840 EAMD-32-32-14-16X20	1133399 EAMK-A-R48-48A	

1) The input torque must not exceed the maximum permissible transferable torque of the axial kit.

Toothed belt axes ELGG

Accessories

Profile mounting MUE (Order code MA)

Materials:
Anodised aluminium
RoHS-compliant

 Note
The central support can also be attached using the profile mounting.

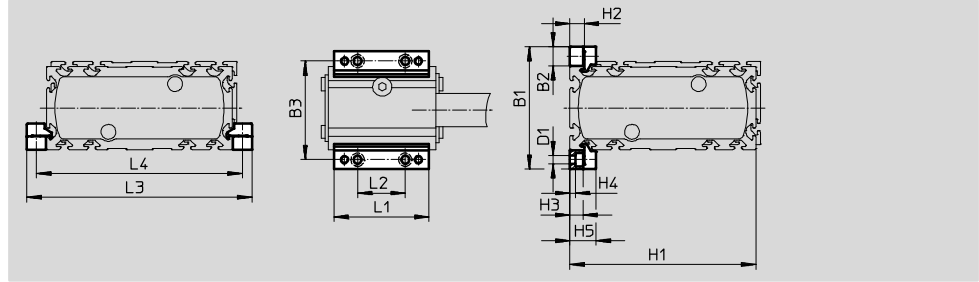

Dimensions and ordering data								
For size	B1	B2	B3	D1	H1	H2	H3	H4
35	51	8	43	3.4	78	6	5.5	2.3
45	69	12	57	5.5	115	10	9	3.2
55	79	12	67	5.5	135	10	9	3.2

For size	H5	L1	L2	L3	L4	Weight [g]	Part No.	Type
35	11	40	20	94	86	20	558042	MUE-50
45	17.5	52	40	139	127	32	562238	MUE-45
55	17.5	52	40	159	147	32	562238	MUE-45

Sensor bracket EAPM-...-SHS, switch lug EAPM-...-SLS (order code SA/SB)

Materials:
Switch lug: Galvanised steel
Sensor bracket: Wrought aluminium alloy, anodised
RoHS-compliant

 Note
The sensor bracket can also be mounted on the central support.

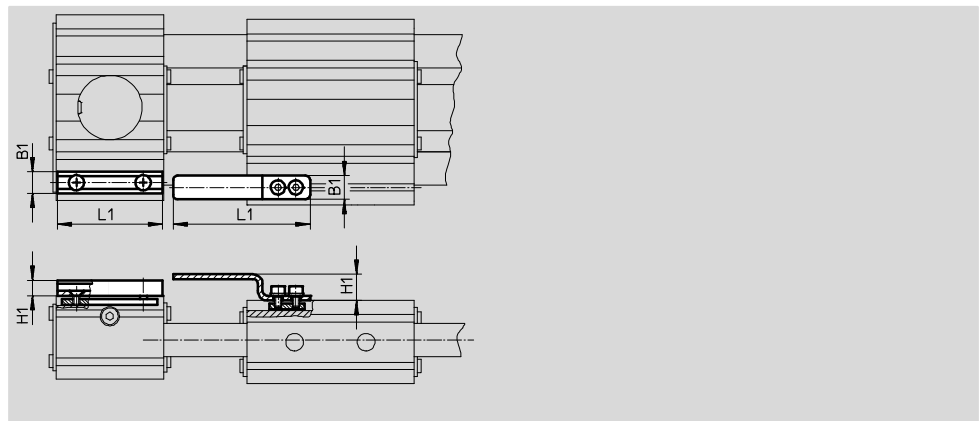

Dimensions and ordering data								
For size	B1	H1	L1	Weight [g]	Part No.	Type		
Sensor bracket								
35, 45, 55	9	6.5	44	20	567537	EAPM-L4-SHS		
Switch lug								
35, 45, 55	10	11	57.5	15	567538	EAPM-L4-SLS		

Toothed belt axes ELGG

Accessories

FESTO

Drive shaft EAMB
Alternative interface
(Order code EA)

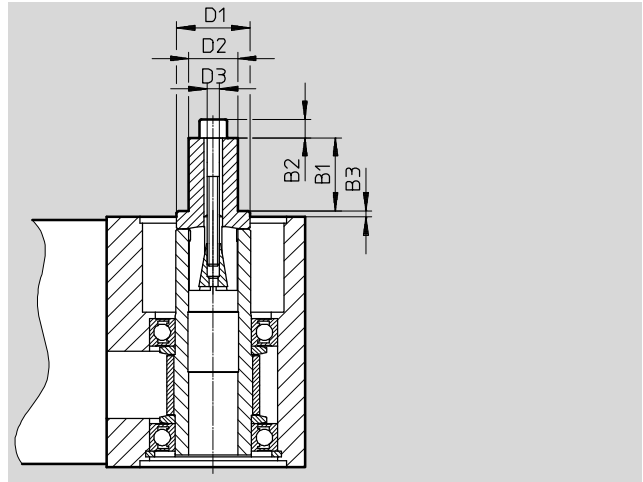

Dimensions and ordering data									
For size	B1	B2	B3	D1 ∅	D2 ∅	D3	Weight [g]	Part No.	Type
35	12	3	3.9	16	8	M4	20	558034	EAMB-16-7-8X15-8X10
45	12	4	6	18	8	M5	29	558035	EAMB-18-9-8X16-10X12
55	21	-	1.5	24	15	M6	70	558036	EAMB-24-6-15X21-16X20

Ordering data						
	For size	Comment	Order code	Part No.	Type	PU ¹⁾
Slot nut NST						
	35	For mounting slot	NM	558045	NST-3-M3	1
	45, 55			150914	NST-5-M5	
Centring sleeve ZBH²⁾						
	35, 45, 55	For slide	-	186717	ZBH-7	10
Slot cover ABP						
	45, 55	For mounting slot Every 0.5 m	NC	151681	ABP-5	2

1) Packaging unit quantity



2) 4 centring sleeves included in the scope of delivery of the axis

Toothed belt axes ELGG

Accessories

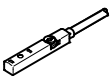
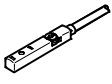
FESTO

Ordering data – Proximity sensor for T-slot, inductive						Technical data → Internet: sies	
	Type of mounting	Electrical connection	Switching output	Cable length [m]	Order code	Part No.	Type
N/O contact							
	Insertable in the slot from above, flush with the cylinder profile	Cable, 3-wire	PNP	7.5	SA	551386	SIES-8M-PS-24V-K-7,5-OE
		Plug connector M8x1, 3-pin		0.3	–	551387	SIES-8M-PS-24V-K-0,3-M8D
		Cable, 3-wire	NPN	7.5	–	551396	SIES-8M-NS-24V-K-7,5-OE
		Plug connector M8x1, 3-pin		0.3	–	551397	SIES-8M-NS-24V-K-0,3-M8D
N/C contact							
	Insertable in the slot from above, flush with the cylinder profile	Cable, 3-wire	PNP	7.5	SB	551391	SIES-8M-PO-24V-K-7,5-OE
		Plug connector M8x1, 3-pin		0.3	–	551392	SIES-8M-PO-24V-K-0,3-M8D
		Cable, 3-wire	NPN	7.5	–	551401	SIES-8M-NO-24V-K-7,5-OE
		Plug connector M8x1, 3-pin		0.3	–	551402	SIES-8M-NO-24V-K-0,3-M8D

Ordering data – Connecting cables				Technical data → Internet: nebu	
	Electrical connection, left	Electrical connection, right	Cable length [m]	Part No.	Type
	Straight socket, M8x1, 3-pin	Cable, open end, 3-wire	2.5	541333	NEBU-M8G3-K-2.5-LE3
			5	541334	NEBU-M8G3-K-5-LE3
	Angled socket, M8x1, 3-pin	Cable, open end, 3-wire	2.5	541338	NEBU-M8W3-K-2.5-LE3
			5	541341	NEBU-M8W3-K-5-LE3

Product Range and Company Overview

A Complete Suite and Company Overview

Our experienced engineers provide complete support at every stage of your development process, including: conceptualization, analysis, engineering, design, assembly, documentation, validation, and production.

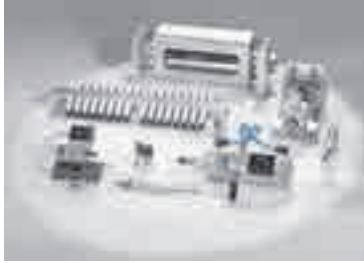

Custom Automation Components
Complete custom engineered solutions



Custom Control Cabinets
Comprehensive engineering support and on-site services

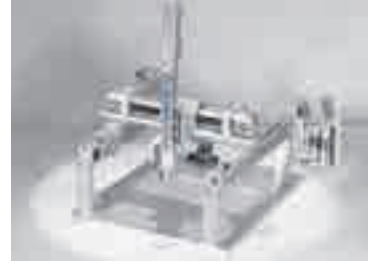

Complete Systems
Shipment, stocking and storage services

The Broadest Range of Automation Components

With a comprehensive line of more than 30,000 automation components, Festo is capable of solving the most complex automation requirements.



Electromechanical
Electromechanical actuators, motors, controllers & drivers



Pneumatics
Pneumatic linear and rotary actuators, valves, and air supply



PLCs and I/O Devices
PLC's, operator interfaces, sensors and I/O devices

Supporting Advanced Automation... As No One Else Can!

Festo is a leading global manufacturer of pneumatic and electromechanical systems, components and controls for industrial automation, with more than 16,000 employees in 60 national headquarters serving more than 180 countries. For more than 80 years, Festo has continuously elevated the state of manufacturing with innovations and optimized motion control solutions that deliver higher performing, more profitable automated manufacturing and processing equipment. Our dedication to the advancement of automation extends beyond technology to the education and development of current and future automation and robotics designers with simulation tools, teaching programs, and on-site services.

Quality Assurance, ISO 9001 and ISO 14001 Certifications

Festo Corporation is committed to supply all Festo products and services that will meet or exceed our customers' requirements in product quality, delivery, customer service and satisfaction.

To meet this commitment, we strive to ensure a consistent, integrated, and systematic approach to management that will meet or exceed the requirements of the ISO 9001 standard for Quality Management and the ISO 14001 standard for Environmental Management.



© Copyright 2013, Festo Corporation. While every effort is made to ensure that all dimensions and specifications are correct, Festo cannot guarantee that publications are completely free of any error, in particular typing or printing errors. Accordingly, Festo cannot be held responsible for the same. For Liability and Warranty conditions, refer to our "Terms and Conditions of Sale", available from your local Festo office. All rights reserved. No part of this publication may be reproduced, distributed, or transmitted in any form or by any means, electronic, mechanical, photocopying or otherwise, without the prior written permission of Festo. All technical data subject to change according to technical update.



Printed on recycled paper at New Horizon Graphic, Inc., FSC certified as an environmental friendly printing plant.

Festo North America

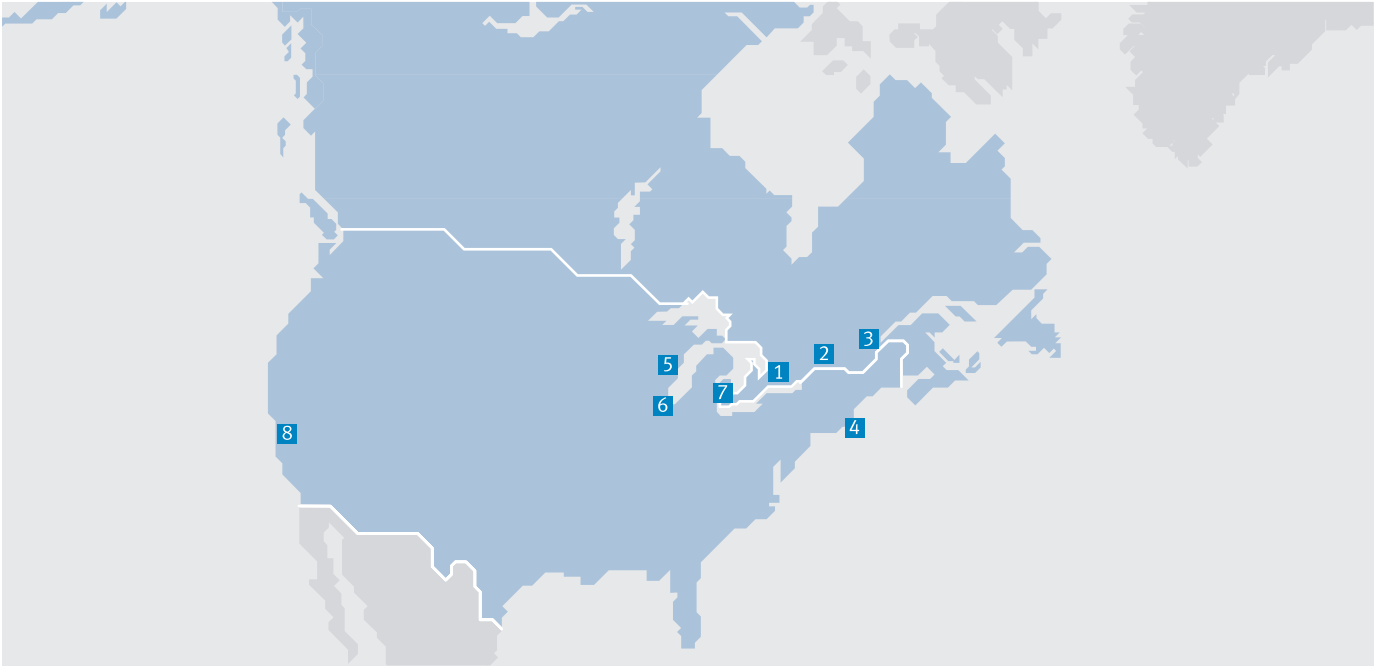

**1 Festo Canada
Headquarters
Festo Inc.**
5300 Explorer Drive
Mississauga, ON
L4W 5G4

2 Montréal
5600, Trans-Canada
Pointe-Claire, QC
H9R 1B6

3 Québec City
2930, rue Watt#117
Québec, QC
G1X 4G3



**4 Festo United States
Headquarters
Festo Corporation**
395 Moreland Road
Hauppauge, NY
11788

5 Appleton
North 922 Tower View Drive, Suite N
Greenville, WI
54942

7 Detroit
1441 West Long Lake Road
Troy, MI
48098

6 Chicago
85 W Algonquin - Suite 340
Arlington Heights, IL
60005

8 Silicon Valley
4935 Southfront Road, Suite F
Livermore, CA
94550

Festo Regional Contact Center

Canadian Customers

Commercial Support:
Tel: 1 877 GO FESTO (1 877 463 3786)
Fax: 1 877 FX FESTO (1 877 393 3786)
Email: festo.canada@ca.festo.com

Technical Support:

Tel: 1 866 GO FESTO (1 866 463 3786)
Fax: 1 877 FX FESTO (1 877 393 3786)
Email: technical.support@ca.festo.com

USA Customers

Commercial Support:
Tel: 1 800 99 FESTO (1 800 993 3786)
Fax: 1 800 96 FESTO (1 800 963 3786)
Email: customer.service@us.festo.com

Technical Support:

Tel: 1 866 GO FESTO (1 866 463 3786)
Fax: 1 800 96 FESTO (1 800 963 3786)
Email: product.support@us.festo.com