

Toothed belt axes EGC-HD-TB, with heavy-duty guide

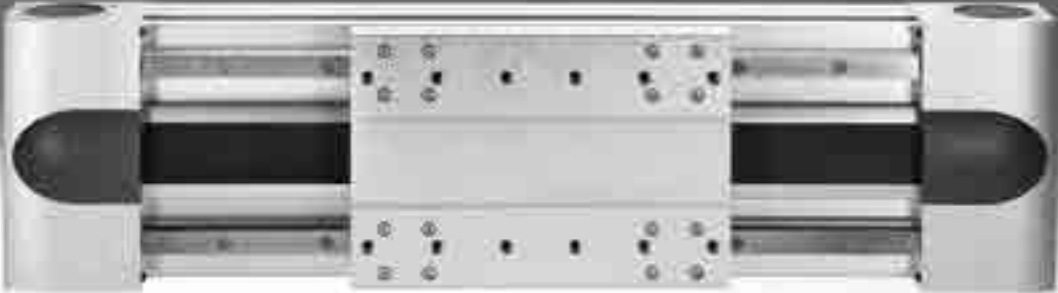

Electromechanical drives

Selection aid



Overview of toothed belt and spindle axes

Toothed belt axes

- Speeds of up to 10 m/s
- Acceleration of up to 50 m/s²
- Repetition accuracy of up to ±0.08 mm
- Strokes of up to 8500 mm (longer strokes on request)
- Flexible motor mounting

Spindle axes

- Speeds of up to 2 m/s
- Acceleration of up to 20 m/s²
- Repetition accuracy of up to ±0.003 mm
- Strokes of up to 3000 mm

Coordinate system

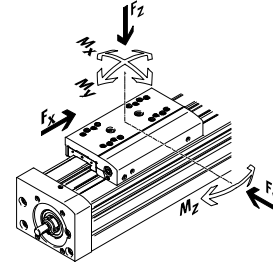

Toothed belt axes

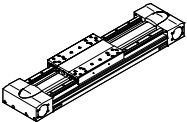
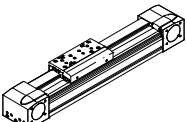
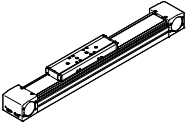
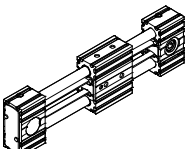
Type	F_x [N]	v [m/s]	M_x [Nm]	M_y [Nm]	M_z [Nm]	Properties
Heavy-duty recirculating ball bearing guide						
EGC-HD-TB						
	450 1000 1800	3 5 5	140 300 900	275 500 1450	275 500 1450	<ul style="list-style-type: none"> • Flat drive unit with rigid, closed profile • Precision, resilient DUO guide rail • Ideal as a basic axis for linear gantries and cantilever axes
Recirculating ball bearing guide						
EGC-TB-KF						
	50 100 350 800 2500	3 5 5 5 5	3.5 16 36 144 529	10 132 228 680 1820	10 132 228 680 1820	<ul style="list-style-type: none"> • Rigid, closed profile • Precision, resilient guide rail • Small drive pinions reduce necessary driving torque • Space-saving position sensing
ELGA-TB-KF						
	350 800 1300 2000	5 5 5 5	16 36 104 167	132 228 680 1150	132 228 680 1150	<ul style="list-style-type: none"> • Internal guide and toothed belt • Precision, resilient guide rail • Guide and toothed belt protected by cover strip • High feed forces
ELGR-TB						
	50 100 350	3 3 3	2.5 5 15	20 40 124	20 40 124	<ul style="list-style-type: none"> • Cost-optimised rod guide • Ready-to-install unit • Resilient ball bearings for dynamic operation

Electromechanical drives

Selection aid

Overview of toothed belt and spindle axes

Toothed belt axes

- Speeds of up to 10 m/s
- Acceleration of up to 50 m/s²
- Repetition accuracy of up to ±0.08 mm
- Strokes of up to 8500 mm (longer strokes on request)
- Flexible motor mounting

Spindle axes

- Speeds of up to 2 m/s
- Acceleration of up to 20 m/s²
- Repetition accuracy of up to ±0.003 mm
- Strokes of up to 3000 mm

Coordinate system

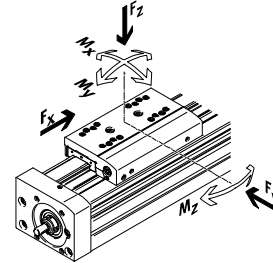

Toothed belt axes

Type	F_x [N]	v [m/s]	M_x [Nm]	M_y [Nm]	M_z [Nm]	Properties
Roller bearing guide						
ELGA-TB-RF						
	350	10	11	40	40	<ul style="list-style-type: none"> • Sturdy roller bearing guide • Guide and toothed belt protected by cover strip • Speeds of up to 10 m/s • Lower weight than axes with guide rails
	800	10	30	180	180	
	1300	10	100	640	640	
ELGA-TB-RF-F1						
	260	10	8.8	32	32	<ul style="list-style-type: none"> • Suitable for use in the food zone • Sturdy roller bearing guide • Guide and toothed belt protected by cover strip • Speeds of up to 10 m/s • Lower weight than axes with guide rails
	600	10	24	144	144	
	1000	10	80	512	512	
Plain-bearing guide						
ELGA-TB-G						
	350	5	5	30	10	<ul style="list-style-type: none"> • Guide and toothed belt protected by cover strip • For simple handling tasks • As an actuator for external guides • Insensitive to harsh environmental conditions
	800	5	10	60	20	
	1300	5	120	120	40	
ELGR-TB-GF						
	50	1	1	10	10	<ul style="list-style-type: none"> • Cost-optimised rod guide • Ready-to-install unit • Heavy-duty plain bearings for use in harsh environmental conditions
	100	1	2.5	20	20	
	350	1	1	40	40	

Electromechanical drives

Selection aid



Overview of toothed belt and spindle axes

Toothed belt axes	Spindle axes	Coordinate system
<ul style="list-style-type: none"> • Speeds of up to 10 m/s • Acceleration of up to 50 m/s² • Repetition accuracy of up to ±0.08 mm • Strokes of up to 8500 mm (longer strokes on request) • Flexible motor mounting 	<ul style="list-style-type: none"> • Speeds of up to 2 m/s • Acceleration of up to 20 m/s² • Repetition accuracy of up to ±0.003 mm • Strokes of up to 3000 mm 	

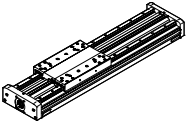
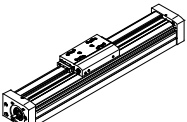
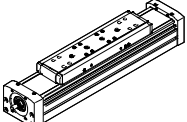
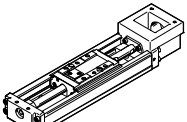
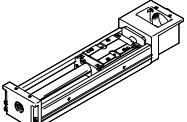
Spindle axes						
Type	F_x [N]	v [m/s]	M_x [Nm]	M_y [Nm]	M_z [Nm]	Properties
Heavy-duty recirculating ball bearing guide						
EGC-HD-BS						
	300 600 1300	0.5 1.0 1.5	140 300 900	275 500 1450	275 500 1450	<ul style="list-style-type: none"> • Flat drive unit with rigid, closed profile • Precision, resilient DUO guide rail • Ideal as a basic axis for linear gantries and cantilever axes
Recirculating ball bearing guide						
EGC-BS-KF						
	300 600 1300 3000	0.5 1.0 1.5 2.0	16 36 144 529	132 228 680 1820	132 228 680 1820	<ul style="list-style-type: none"> • Rigid, closed profile • Precision, resilient guide rail • For extremely high requirements for speed force and precision • Space-saving position sensing
ELGA-BS-KF						
	300 600 1300 3000	0.5 1.0 1.5 2.0	16 36 104 167	132 228 680 1150	132 228 680 1150	<ul style="list-style-type: none"> • Internal guide and ball screw • Precision guide rail with high load capacity • For the highest requirements for feed force and precision • Guide and ball screw protected by cover strip • Space-saving position sensing
EGSK						
	57 133 184 239 392	0.33 1.10 0.83 1.10 1.48	13 28.7 60 79.5 231	3.7 9.2 20.4 26 77.3	3.7 9.2 20.4 26 77.3	<ul style="list-style-type: none"> • Spindle axes with maximum precision, compactness and rigidity • Recirculating ball bearing guide and ball screw without caged ball bearings • Standard designs in stock
EGSP						
	112 212 466 460	0.6 0.6 2.0 2.0	36.3 81.5 90.3 258	12.5 31.6 32.1 94	12.5 31.6 32.1 94	<ul style="list-style-type: none"> • Spindle axes with maximum precision, compactness and rigidity • Recirculating ball bearing guide with caged ball bearings • Ball screw sizes 33, 46 with caged ball bearings

Toothed belt axes EGC-HD-TB, with heavy-duty guide

Key features

At a glance

- New heavy-duty guide for:
 - Maximum loads and torques
 - High feed forces and speeds
 - Long service life
- Precision, resilient DUO guide rail
- Ideal as a basic axis for linear gantries and cantilever axes
- In addition to its technical data, the toothed belt axis also offers an excellent price/performance ratio
- Space-saving position sensing with proximity sensor in the profile slot
- Wide range of options for mounting on drives

Flexible motor mounting

The motor position can be freely selected on four sides and can be changed at any time.



Flat unit with rigid, closed profile

EGC-HD-125

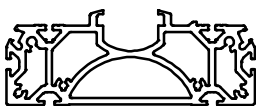

EGC-HD-160

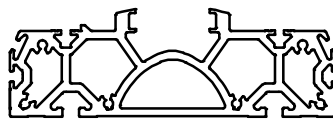

EGC-HD-220

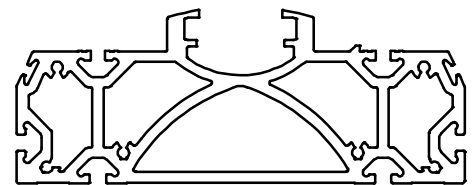

Characteristic values of the axes

The specifications shown in the table are maximum values.

The precise values for each of the variants can be found in the relevant technical data section.

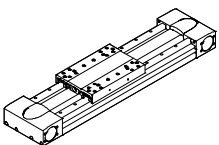
Version	Size	Working stroke [mm]	Speed [m/s]	Repetition accuracy [mm]	Feed force [N]	Guide characteristics				
						Forces and torques				
						Fy [N]	Fz [N]	Mx [Nm]	My [Nm]	Mz [Nm]
Recirculating ball bearing guide										
	125	50 ... 3000	3	+0.08	450	3650	3650	140	275	275
	160	50 ... 5000	5	+0.08	1000	5600	5600	300	500	500
	220	50 ... 4750	5	+0.1	1800	13000	13000	900	1450	1450

-  - Note
PositioningDrives
sizing software
www.festo.com

Toothed belt axes EGC-HD-TB, with heavy-duty guide

Key features

Slide variants

Standard slide



Standard slide, protected



With additional slide



Complete system comprising toothed belt axis, motor, motor controller and motor mounting kit

Toothed belt axis with recirculating ball bearing guide



Motor

→ 24



1

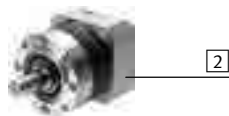

2

- 1 Servo motor EMME-AS, EMMS-AS
- 2 Gear unit EMGA

- - Note

A range of specially adapted complete solutions is available for the toothed belt axis EGC and the motors.

Motor controller

Technical data → Internet: motorcontroller



Servo motor controller
CMMP-AS

Motor mounting kit

→ 24

Axial kit



Kit comprising:

- Motor flange
- Coupling housing
- Coupling
- Screws

Toothed belt axes EGC-HD-TB, with heavy-duty guide

Type codes

	EGC	-	HD	-	125	-	500	-	TB	-	50H	-	GK
Type													
EGC	Toothed belt axis												
Guide													
HD	Heavy-duty guide												
Size													
Stroke [mm]													
Drive function													
TB	Toothed belt												
Stroke reserve													
Slide													
GK	Standard slide												
GP	Standard slide, protected												

→		-		ZUB	-	2MX2Z	-	DN
Additional slide								
KL	Standard, left							
Additional slide								
KR	Standard, right							
Accessories enclosed separately								
...M	Profile mounting							
...B	Mounting slot cover							
...S	Sensor slot cover							
...Y	Slot nut for mounting slot							
...X	Proximity sensor (SIES), inductive, slot type 8, PNP, N/O contact, 7.5 m cable							
...Z	Proximity sensor (SIES), inductive, slot type 8, PNP, N/C contact, 7.5 m cable							
...A	Emergency buffer with retainer							
...C	Shock absorber with retainer							
...O	Proximity sensor (SIEN), inductive, M8, PNP, N/O contact, 2.5 m cable							
...P	Proximity sensor (SIEN), inductive, M8, PNP, N/C contact, 2.5 m cable							
...W	Proximity sensor (SIEN), inductive, M8, PNP, N/O contact, plug M8							
...R	Proximity sensor (SIEN), inductive, M8, PNP, N/C contact, plug M8							
...V	Connecting cable							
...CL	Cable clip							
Operating instructions								
DN	None							

Toothed belt axes EGC-HD-TB, with heavy-duty guide

Peripherals overview

FESTO

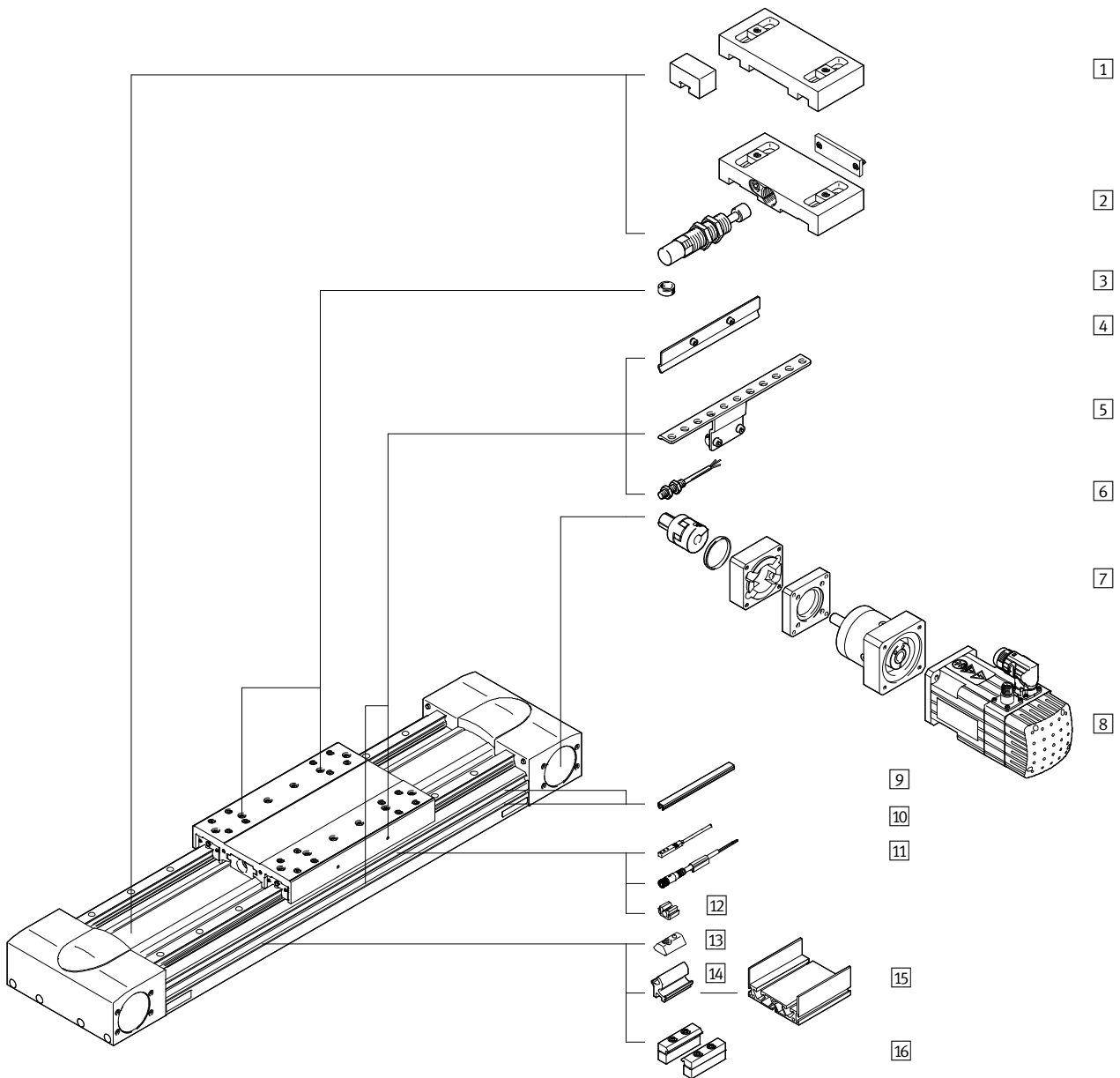

Toothed belt axes EGC-HD-TB, with heavy-duty guide

Peripherals overview



Variants and accessories		
Type	Description	→ Page/Internet
1 Emergency buffer with retainer A	For avoiding damage at the end stop in the event of malfunction	26
2 Shock absorber with retainer C	For avoiding damage at the end stop in the event of malfunction	26
3 Centring pin/sleeve ZBS, ZBH	<ul style="list-style-type: none"> For centring loads and attachments on the slide 2 centring pins/sleeves included in the scope of delivery of the axis 	28
4 Switch lug X, Z, O, P, W, R	For sensing the slide position	26
5 Sensor bracket O, P, W, R	Adapter for mounting the inductive proximity sensors (round design) on the axis	26
6 Proximity sensor, M8 O, P, W, R	<ul style="list-style-type: none"> Inductive proximity sensor, round design The order code O, P, W, R includes 1 switch lug and max. 2 sensor brackets 	29
7 Axial kit EAMM-A	For axial motor mounting (consisting of: coupling, coupling housing and motor flange)	24
8 Motor EMME, EMMS	Motors specially matched to the axis, with gear unit, with or without brake	24
9 Slot cover B, S	<ul style="list-style-type: none"> For protecting against the ingress of dirt 	28
10 Proximity sensor, T-slot X, Z	<ul style="list-style-type: none"> Inductive proximity sensor, for T-slot The order code X, Z includes 1 switch lug 	29
11 Connecting cable V	For proximity sensor (order code W and R)	29
12 Clip CL	For mounting the proximity sensor cable in the slot	28
13 Slot nut Y	For mounting attachments	28
14 Adapter kit DHAM	For mounting the support profile on the axis	35
15 Auflageprofil HMIA	For mounting and guiding an energy chain	35
16 Profile mounting M	For mounting the axis on the profile	25

Toothed belt axes EGC-HD-TB, with heavy-duty guide

Technical data

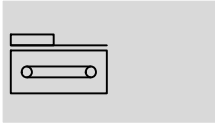
Function



-  Size
125 ... 220
-  Stroke length
50 ... 5000 mm
-  www.festo.com



General technical data				
Size		125	160	220
Design		Electromechanical axis with toothed belt		
Guide		Recirculating ball bearing guide		
Mounting position		Any		
Working stroke	[mm]	50 ... 3000	50 ... 5000	50 ... 4750
Max. feed force F_x	[N]	450	1000	1800
Max. no-load torque ¹⁾	[Nm]	1.1	2.1	4.1
Max. no-load resistance to shifting ¹⁾	[N]	30.79	105.5	123.8
Max. driving torque	[Nm]	7.2	20	59.58
Max. speed				
EGC-...-GK	[m/s]	3	5	
EGC-...-GP	[m/s]	–	3	
Max. acceleration	[m/s ²]	40	50	
Repetition accuracy	[mm]	+0.08		+0.1

1) At 0.2 m/s

Operating and environmental conditions	
Ambient temperature	[°C] –10 ... +60
Protection class	IP40
Duty cycle	[%] 100

Weight [g]				
Size		125	160	220
Basic weight with 0 mm stroke ¹⁾		4720	9050	25510
Additional weight per 10 mm stroke		73	107	210
Slide				
EGC-...-GK		1218	2571	6317
EGC-...-GP		–	2643	6417
Additional slide				
EGC-...-GK		1026	2022	5498
EGC-...-GP		–	2134	5598

1) Incl. slide

Toothed belt axes EGC-HD-TB, with heavy-duty guide

Technical data

Toothed belt				
Size		125	160	220
Pitch	[mm]	3	5	8
Width	[mm]	30.3	40.0	50.5
Expansion ¹⁾	[%]	0.31	0.23	0.29
Effective diameter	[mm]	32.47	39.79	66.21
Feed constant	[mm/rev.]	102	125	208

1) At max. feed force

Mass moment of inertia				
Size		125	160	220
J_0	[kg cm ²]	4,639	14.49	108.99
J_S per metre stroke	[kg cm ² /m]	0.38	1.267	6.269
J_L per kg effective load	[kg cm ² /kg]	2.635	3.96	10.96
J_W Additional slide	[kg cm ²]	3.3	11.734	80.66

The mass moment of inertia J_A of the entire axis is calculated as follows:

$$J_A = J_0 + J_W + J_S \times \text{working stroke [m]} + J_L \times m_{\text{effective load [kg]}}$$

Materials

Sectional view

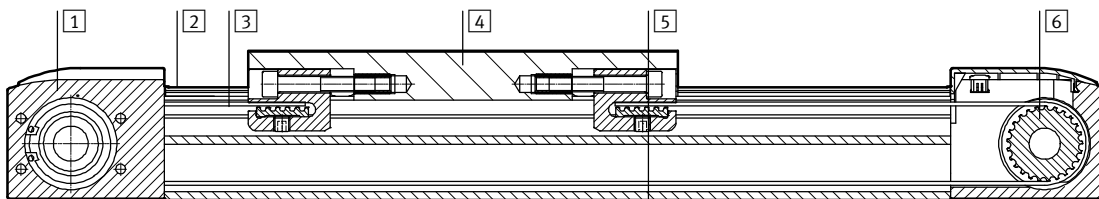

Axis		
1	Drive cover	Anodised wrought aluminium alloy
2	Guide rail	Coated and corrosion-resistant steel
3	Toothed belt	Polychloroprene with glass cord and nylon coating
4	Slide	Anodised wrought aluminium alloy
5	Profile	Anodised wrought aluminium alloy
6	Toothed belt disc	High-alloy stainless steel
Note on materials		Conforms to RoHS
		Contains PWIS (paint-wetting impairment substances)

Toothed belt axes EGC-HD-TB, with heavy-duty guide

Technical data

Characteristic load values

The indicated forces and torques refer to the slide surface. The point of application of force is the point where the centre of the guide and the longitudinal centre of the slide intersect.

These values must not be exceeded during dynamic operation. Special attention must be paid to the deceleration phase.

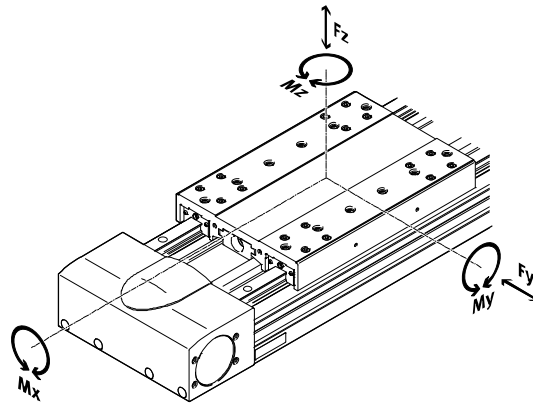

Max. permissible forces and torques for a service life of 5000 km				
Size		125	160	220
F _{y,max.}	[N]	3650	5600	13000
F _{z,max.}	[N]	3650	5600	13000
M _{x,max.}	[Nm]	140	300	900
M _{y,max.}	[Nm]	275	500	1450
M _{z,max.}	[Nm]	275	500	1450

-  - Note

For a service life of 5000 km for the guide system, the load comparison factor must have a value of $f_v < 1$,

based on the maximum permissible forces and torques for a service life of 5000 km.

If the axis is simultaneously subjected to several of the indicated forces and torques, the following equation

must be satisfied in addition to the indicated maximum loads:

Calculating the load comparison factor:

$$f_v = \frac{|F_{y,dyn}|}{F_{y,max}} + \frac{|F_{z,dyn}|}{F_{z,max}} + \frac{|M_{x,dyn}|}{M_{x,max}} + \frac{|M_{y,dyn}|}{M_{y,max}} + \frac{|M_{z,dyn}|}{M_{z,max}}$$

Toothed belt axes EGC-HD-TB, with heavy-duty guide

Technical data

Calculating service life

The service life of the guide depends on the load. To provide a rough indication of the service life of the

guide, the graph below plots the load comparison factor f_v against the service life.

These values are only theoretical. You must consult your local contact

person at Festo for load comparison factors f_v greater than 1.5.

Load comparison factor f_v as a function of service life

Example:

A user wants to move an X kg load.

Using the formula $\rightarrow 12$ gives a value of 1.5 for the load comparison factor f_v . According to the graph, the guide would have a service life of

approx. 1500 km. Reducing the acceleration reduces the M_z and M_y values. A load comparison factor f_v of 1 now gives a service life of 5000 km.

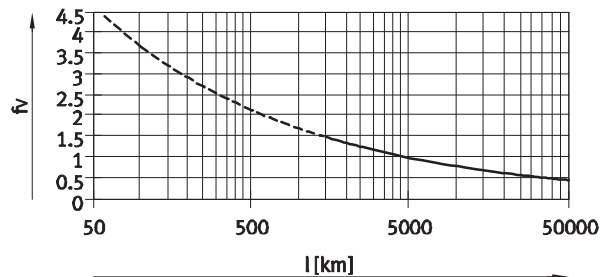

Note

PositioningDrives
sizing software
www.festo.com

The guide workload for a service life of 5000 km can be calculated with the help of the sizing software.

$f_v > 1.5$ are only theoretical comparison values for the recirculating ball bearing guide.

Comparison of the characteristic load values for 5000 km with dynamic forces and torques of recirculating ball bearing guides

The characteristic load values of roller bearing guides are standardised to ISO and JIS using dynamic and static forces and torques. These forces and torques are based on an expected service life for the guide system of 100 km to ISO or 50 km to JIS.

As the characteristic load values are dependent on the service life, the max. permissible forces and torques for a service life of 5000 km cannot be compared with the dynamic forces and torques of roller bearing guides to ISO/JIS.

To make it easier to compare the guide capacity of linear axes EGC with roller bearing guides, the table below lists the theoretically permissible forces and torques for a calculated service life of 100 km. This corresponds to the dynamic forces and torques to ISO.

These 100 km values have been calculated mathematically and are only to be used for comparing with dynamic forces and torques to ISO. The drives must not be loaded with these characteristic values as this could damage them.

Max. permissible forces and torques for a theoretical service life of 100 km (from a guide perspective only)

Size		125	160	220
$F_{y_{max}}$	[N]	13447	20631	47892
$F_{z_{max}}$	[N]	13447	20631	47892
$M_{x_{max}}$	[Nm]	516	1105	3316
$M_{y_{max}}$	[Nm]	1013	1842	5342
$M_{z_{max}}$	[Nm]	1013	1842	5342

Toothed belt axes EGC-HD-TB, with heavy-duty guide

Technical data

Maximum acceleration a as a function of applied load m

EGC-HD-125

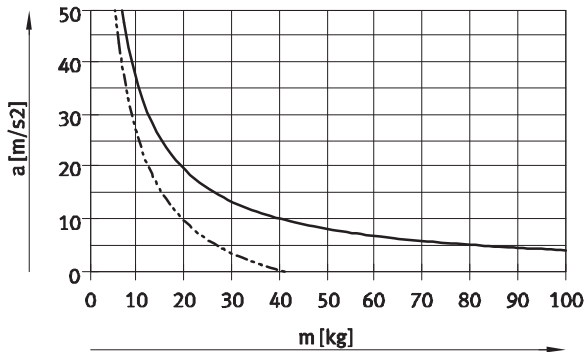

EGC-HD-160

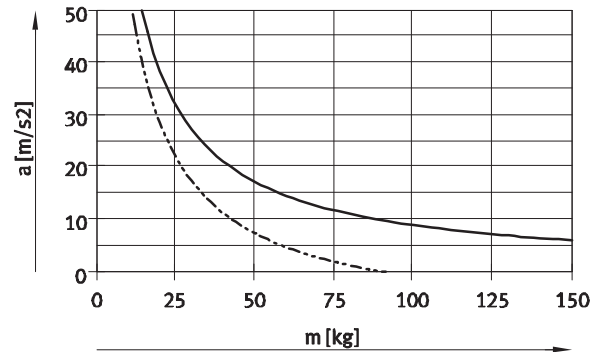

EGC-HD-220

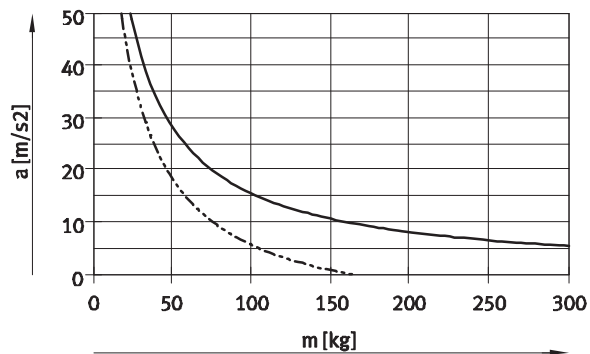

— Horizontal mounting position
 - - - Vertical mounting position

Speed v as a function of rotational speed n

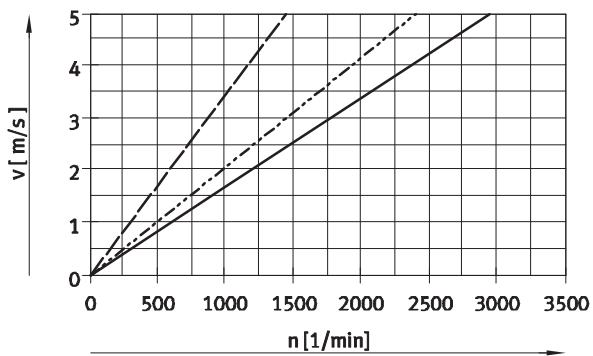

— EGC-HD-125
 - - - EGC-HD-160
 - - - EGC-HD-220

Toothed belt axes EGC-HD-TB, with heavy-duty guide

Technical data

Theoretical feed force F as a function of input torque M

EGC-HD-125

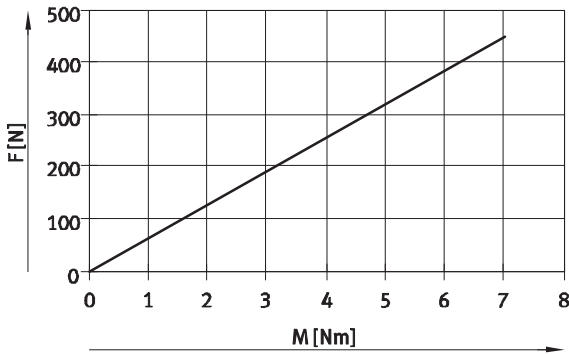

EGC-HD-160

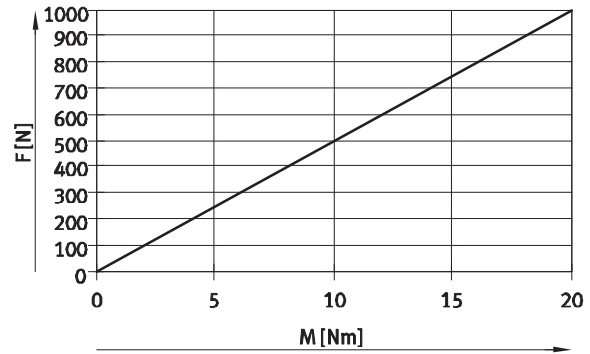

EGC-HD-220

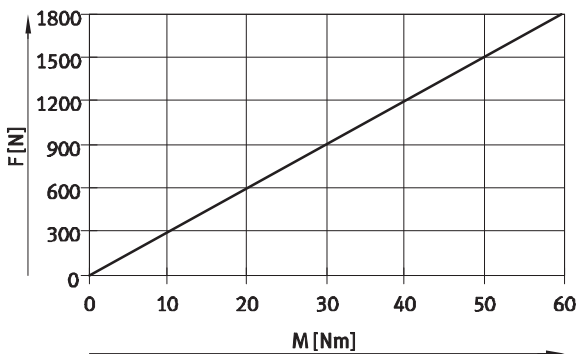

Stroke reserve

Stroke length

The selected stroke corresponds in principle to the required working stroke. The variants GK do not have a long-term lubrication unit on the guide. These variants therefore additionally have a safety distance between the drive cap and slide that is not designated as part of the working stroke.

Stroke reserve

A safety distance (similar to GK) between the drive cap and slide can be defined for the variants GP using the modular product system via the stroke reserve feature. With the variants GK, the stroke reserve and safety distance are added for each end position.

- The stroke reserve length can be freely selected
- The sum of the stroke length and 2x stroke reserve must not exceed the maximum working stroke

Example:

Type:
EGC-HD-125-500-TB-20H-...
Working stroke = 500 mm
2x stroke reserve = 40 mm

Total stroke = 540 mm
(540 mm = 500 mm + 2x 20 mm)

Size	125	160	220
L9 = safety distance with GK [mm] (per end position)	12.5	15.5	20

Toothed belt axes EGC-HD-TB, with heavy-duty guide

Technical data

Working stroke reduction

With standard slide GK/GP with additional slide KL/KR

- With a toothed belt axis with additional slide, the working stroke is reduced by the length of the additional slide L17 and the distance between both slides L18
- If the variant GP is ordered, the additional slide is also protected

L16 = Length of slide
 L17 = Length of additional slide
 L18 = Distance between both slides

Example:

Type: EGC-HD-220-1000-TB-...-GP-KR

L18 = 100 mm

Working stroke = 1000 mm – 328 mm – 100 mm = 572 mm

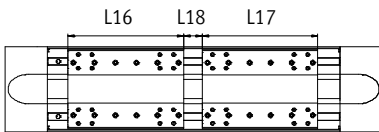

Dimensions – Additional slide

Size	125	160	220
Variant	GK	GK	GP
Length L17 [mm]	202	220	250

Working stroke reduction per side

With integrated emergency buffer NPE/shock absorber YSRW with shock absorber retainer EAYH-L2

- With a toothed belt axis, the working stroke is reduced by the total dimension of the emergency buffer/shock absorber and shock absorber retainer.

Size	125	160	220
With emergency buffer [mm]	65	93	98
With shock absorber [mm]	66	94	99

Second moment of area

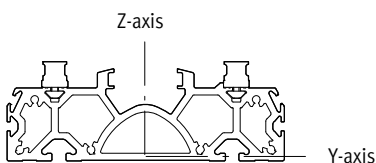

Size	125	160	220
ly [mm ⁴]	6.89x10 ⁵	12.9x10 ⁵	55.8x10 ⁵
lz [mm ⁴]	40.9x10 ⁵	98.9x10 ⁵	351x10 ⁵

Toothed belt axes EGC-HD-TB, with heavy-duty guide

Technical data

Maximum permissible support spacing L (without profile mounting) as a function of force F

In order to limit deflection in the case of large strokes, the axis may need to be supported.

The following graphs help to determine the maximum permissible support spacing L as a function of force F acting on the axis. The deflection is $f = 0.5 \text{ mm}$.

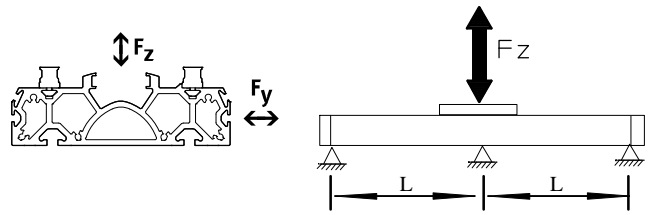

Force Fy

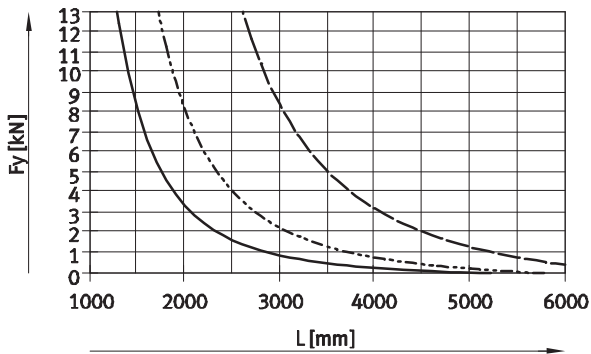

Force Fz

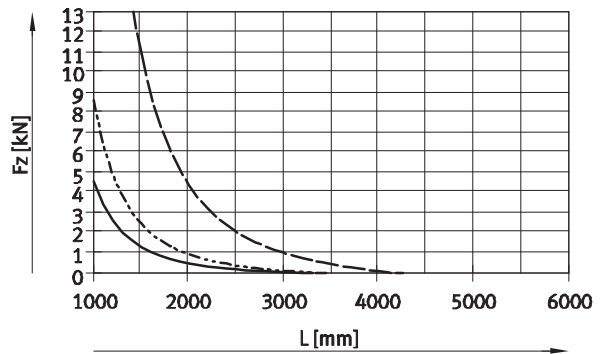

- EGC-HD-125-TB
- - - EGC-HD-160-TB
- · - EGC-HD-220-TB

Recommended deflection limits

Adherence to the following deflection limits is recommended so as not to impair the functional performance of

the axes. Greater deformation can result in increased friction, greater wear and reduced service life.

Size	Dyn. deflection (moving load)	Stat. deflection (stationary load)
125 ... 220	0.05% of the axis length, max. 0.5 mm	0.1% of the axis length

Toothed belt axes EGC-HD-TB, with heavy-duty guide

Technical data

Dimensions

Download CAD data → www.festo.com

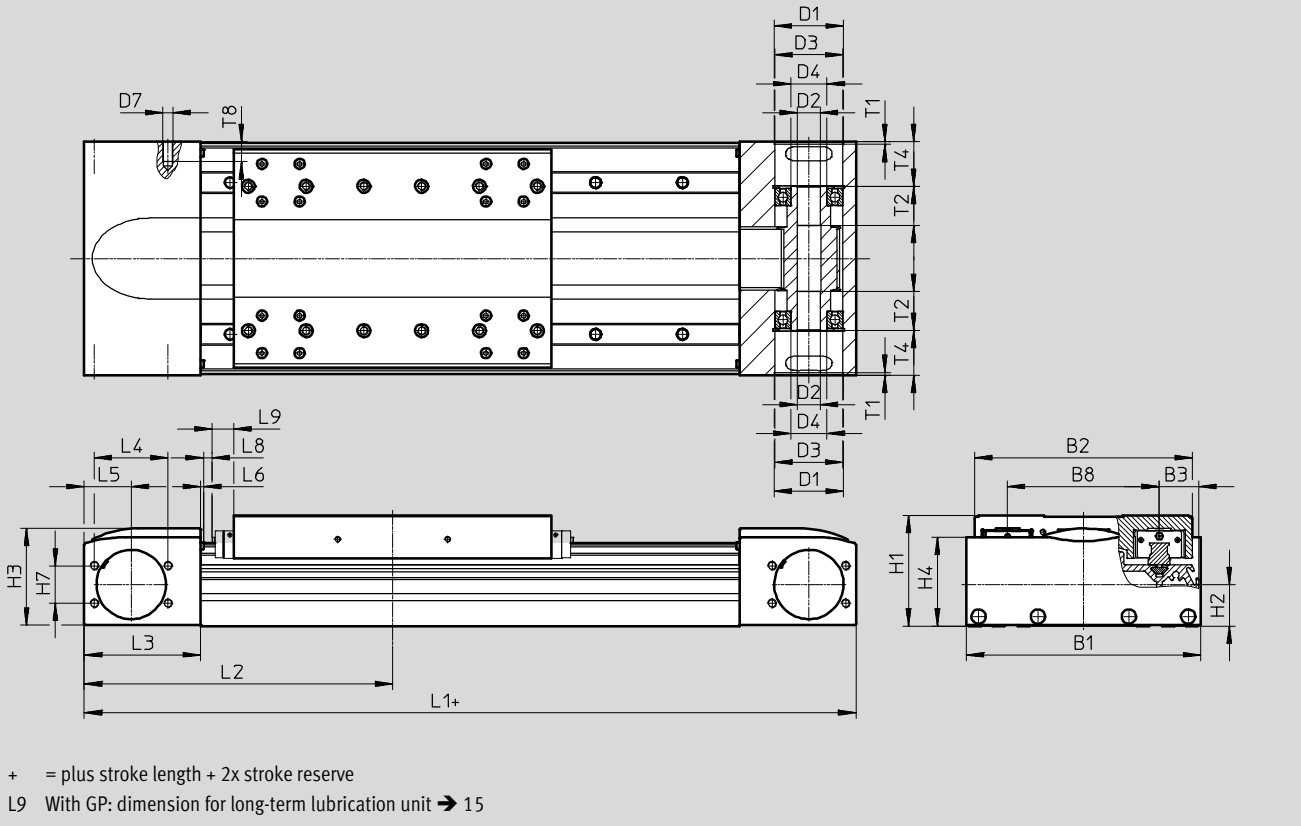

Size	B1	B2	B3	B8	D1 ∅ H7	D2 ∅ H7	D3 ∅	D4 ∅	D7
125	124	120	21	80	43	16	42	25	M6
160	162	150.7	27.5	105	48	16	47	25	M6
220	224	204.2	40	140	80	23	75	45	M8

Size	H1	H2	H3	H4	H7	L1	L2 min.	L3	L4
125	64	26.1	55.8	50.8	24	346	173	57.5	46
160	76.5	28.7	67.5	61.5	26	417	208.5	80.5	51
220	111.5	45.2	98	91.1	59	576	288	115	76

Size	L5	L6	L8	L9	T1	T2	T4	T8
125	27.5	1.8	2	-	2.1	27	23.65	13
160	32.5	2	0.55	14.9	3.1	27	31.1	14
220	50	2	2	18	3.1	29.5	47.5	16

Toothed belt axes EGC-HD-TB, with heavy-duty guide

Technical data

Dimensions Download CAD data → www.festo.com

Profile

1 Sensor slot for proximity sensor
2 Mounting slot for slot nut

Size	B10	B11	H10
125	122	80	20
160	160	100	20
220	220	140	20

GK – Standard slide

Size 125

5 Hole for centring sleeve ZBH
6 Hole for centring pin ZBS

Size	B4	B10	D1 ∅ H7	D2 ∅ H7	D3	D6	H2 ±0.03	H3 ±0.05	H4 ±0.1	L1 ±0.1	L2 ±0.2	L3 ±0.1
125	12	9	5	9	M5	M4	80	80	20	200	190	90

Size	L4 ±0.1	L5 ±0.2	L6 ±0.1	L7 ±0.03	L8 ±0.1	L10 202	L11 ±0.03	T1 7.8	T2 +0.1	T3 +0.1
125	40	56	20	20	10	202	100	7.8	2.1	3.1

Toothed belt axes EGC-HD-TB, with heavy-duty guide

Technical data

Dimensions

Download CAD data → www.festo.com

GK – Standard slide/GP – Standard slide, protected

Size 160

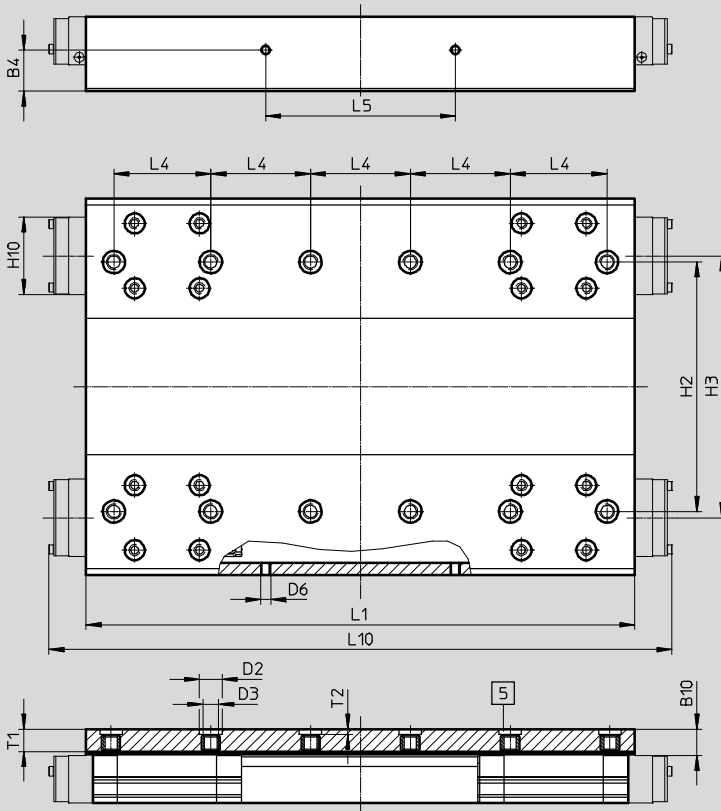

5 Hole for centring sleeve ZBH

Size	B4	B10 ^{*)}	D2 ∅ H7	D3	D6	H2	H3
160	±0.1 16.5	10.5	9	M6	M4	±0.03 100	±0.05 105

Size	H10 ^{*)}	L1	L4	L5	L10 ^{*)}	T1	T2
160	31	±0.1 220	±0.03 40	±0.1 76	250	9	+0.1 2.1

^{*)} Protected version

Toothed belt axes EGC-HD-TB, with heavy-duty guide

Technical data

Dimensions Download CAD data → www.festo.com
 GK – Standard slide/GP – Standard slide, protected

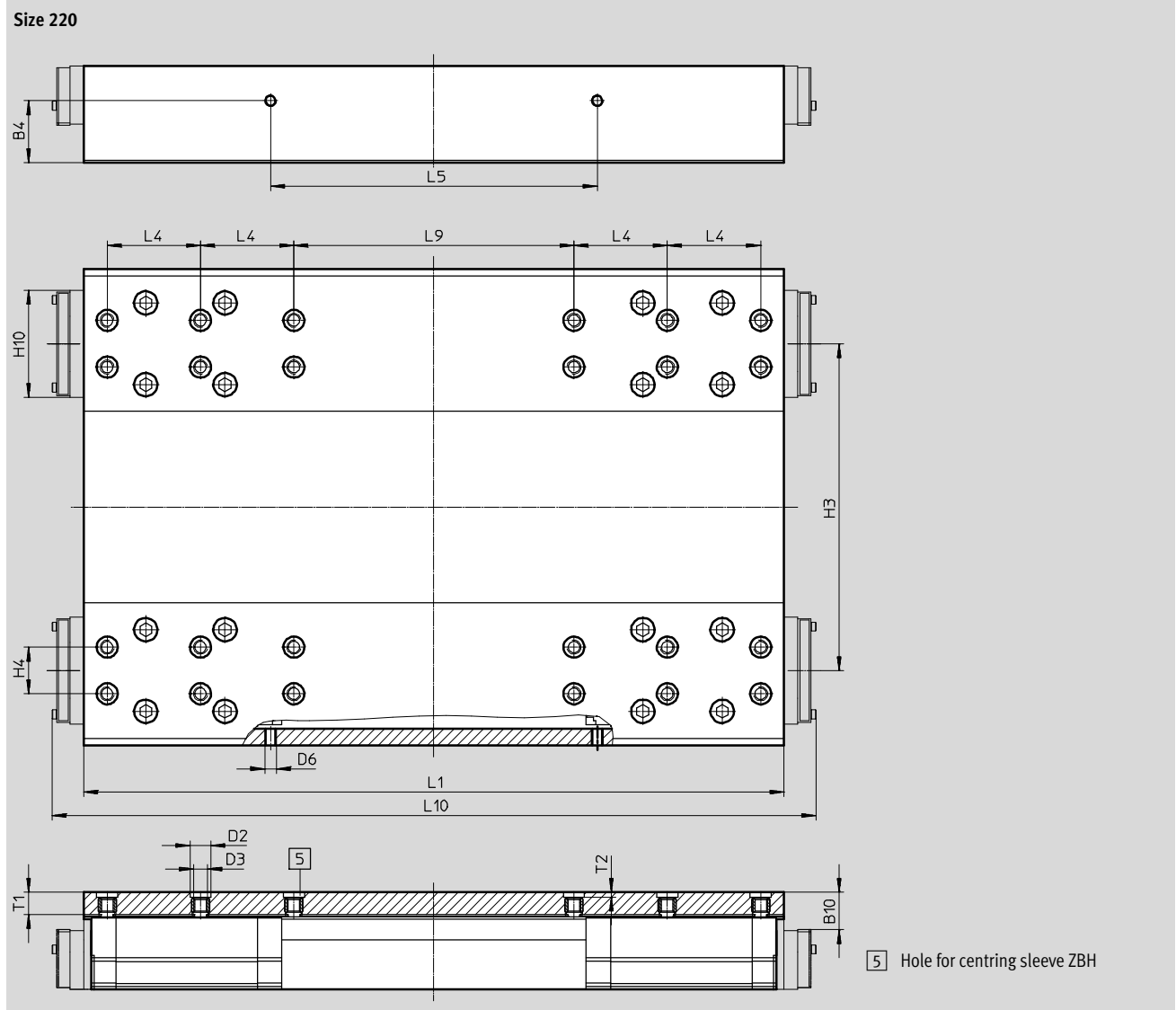

Size	B4	B10 ^{*)}	D2 ∅ H7	D3	D6	H3	H4	H10 ^{*)}
220	±0.1	16	9	M6	M5	±0.05	±0.03	45.95

Size	L1	L4	L5	L9	L10 ^{*)}	T1	T2
220	±0.1	±0.03	±0.1	±0.03	328	9.5	+0.1

^{*)} Protected version

Toothed belt axes EGC-HD-TB, with heavy-duty guide

Ordering data – Modular products

Order code
Mandatory data

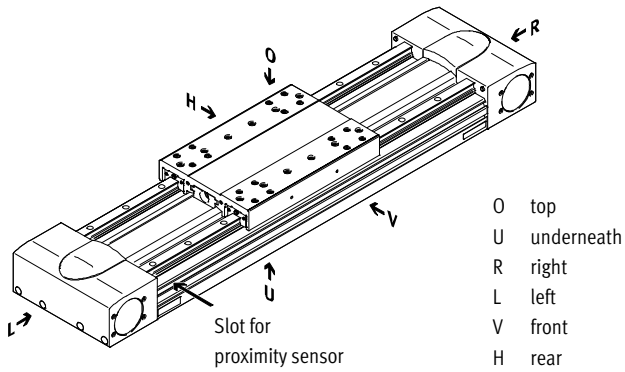

- O top
- U underneath
- R right
- L left
- V front
- H rear

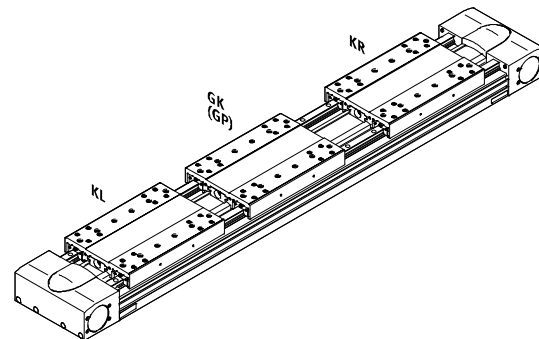

Accessories

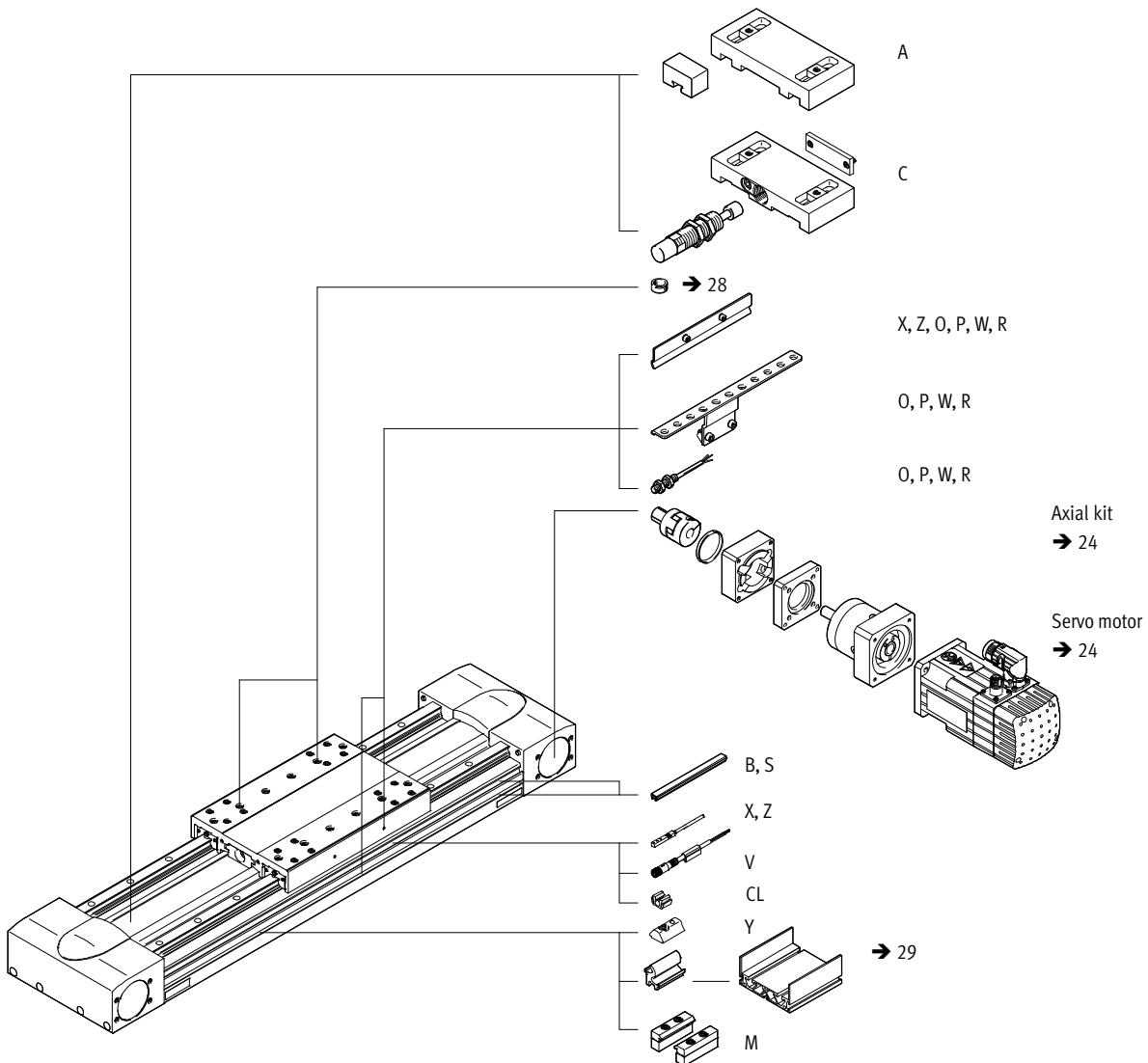

Toothed belt axes EGC-HD-TB, with heavy-duty guide

Ordering data – Modular products

Ordering table							
Size	125	160	220	Condi- tions	Code		Enter code
M Module No.	556823	556824	556825				
Design	Linear axis				EGC		EGC
Guide	Heavy-duty guide				-HD		-HD
Size	125	160	220		-...		-...
Stroke [mm]	50 ... 3000	50 ... 5000	50 ... 4750	1	-...		-...
Function	Toothed belt				-TB		-TB
Stroke reserve [mm]	0 ... 999 (0 = no stroke reserve)			1	-...H		
Slide	Standard slide				-GK		
	-	Standard slide, protected			-GP		
O Additional slide	Left	Additional slide, standard, on left		2	-KL		
	Right	Additional slide, standard, on right		2	-KR		
Accessories	Accessories enclosed separately				ZUB-		ZUB-
Profile mounting	1 ... 50				...M		
Cover	Mounting slot	1 ... 50 (1 = 2x 500 mm pieces)		4	...B		
	Sensor slot	1 ... 50			...S		
Slot nut for mounting slot	1 ... 99			4	...Y		
Proximity sensor (SIES), inductive, slot type 8, PNP, incl. switch lug	N/O contact, 7.5 m cable	1 ... 6			...X		
	N/C contact, 7.5 m cable	1 ... 6			...Z		
Emergency buffer with retainer	1 ... 2			3	...A		
Shock absorber with retainer	1 ... 2			3	...C		
Proximity sensor (SIEN), inductive, M8, PNP, incl. switch lug with sensor bracket	N/O contact, 2.5 m cable	1 ... 99			...O		
	N/C contact, 2.5 m cable	1 ... 99			...P		
Connecting cable, M8, 3-wire, 2.5 m	N/O contact, plug M8	1 ... 99			...W		
	N/C contact, plug M8	1 ... 99			...R		
Cable clip	10, 20, 30, 40, 50, 60, 70, 80, 90				...CL		
Operating instructions	Express waiver - no user documentation to be included (already available) (operating instructions in PDF format are available free of charge on the Internet at http://www.festo.com)				-DN		

- 1** -... The sum of the stroke length in mm and 2x the stroke reserve in mm must not exceed the maximum stroke length in mm.
- 2** **KL, KR** If the protected slide variant (GP) is selected, then the additional slide (KL, KR) is also protected.
- 3** ... **A, ... C** Cannot be combined with slide GP.
- 4** **B, Y** Scope of delivery with size 160 for both slot sizes (→ 34).



- M** Mandatory data
- O** Options

Order code

Toothed belt axes EGC-HD-TB, with heavy-duty guide

Accessories

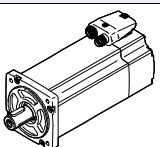
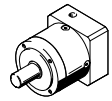
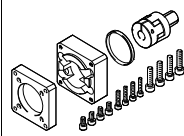
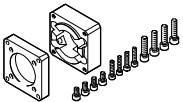
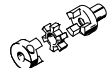
-  - Note
Depending on the combination of motor and drive, it may not be possible to reach the maximum feed force of the drive.

Permissible axis/motor combinations with axial kit – With gear unit						Technical data → Internet: eamm-a
Motor ¹⁾	Gear unit	Axial kit	Axial kit comprises:			
			Motor flange	Coupling	Centring ring	
						
Type	Type	Part No. Type	Part No. Type	Part No. Type	Part No. Type	
EGC-HD-125						
With servo motor						
EMMS-AS-55-...	EMGA-60-P-G...-SAS-55	1190076 EAMM-A-M43-60G	1597579 EAMF-A-43D-60G/H	558001 EAMD-32-32-11-16X20	575962 EAML-43-4-43	
EMME-AS-60-...	EMGA-60-P-G...-EAS-60	1456612 EAMM-A-M43-60H	1597579 EAMF-A-43D-60G/H	1377840 EAMD-32-32-14-16X20	575962 EAML-43-4-43	
EMMS-AS-70-...	EMGA-60-P-G...-SAS-70	1190076 EAMM-A-M43-60G	1597579 EAMF-A-43D-60G/H	558001 EAMD-32-32-11-16X20	575962 EAML-43-4-43	
With stepper motor						
EMMS-ST-57-...	EMGA-60-P-G...-SST-57	1190076 EAMM-A-M43-60G	1597579 EAMF-A-43D-60G/H	558001 EAMD-32-32-11-16X20	575962 EAML-43-4-43	
With integrated drive						
EMCA-ST-67-...	EMGC-60-...	1456612 EAMM-A-M43-60H	1597579 EAMF-A-43D-60G/H	1377840 EAMD-32-32-14-16X20	575962 EAML-43-4-43	
EGC-HD-160						
With servo motor						
EMME-AS-60-...	EMGA-60-P-G...-EAS-60	1456614 EAMM-A-M48-60H	1460111 EAMF-A-48C-60G/H	3420022 EAMD-42-40-14-16X25-U	558031 EAML-48-4-48	
EMMS-AS-70-...	EMGA-80-P-G...-SAS-70	1190421 EAMM-A-M48-80G	1190375 EAMF-A-48C-80G	1781043 EAMD-42-40-20-16X25-U	558031 EAML-48-4-48	
EMME-AS-80-...	EMGA-80-P-G...-EAS-80	1190421 EAMM-A-M48-80G	1190375 EAMF-A-48C-80G	1781043 EAMD-42-40-20-16X25-U	558031 EAML-48-4-48	
EMMS-AS-100-...	EMGA-80-P-G...-SAS-100	1190421 EAMM-A-M48-80G	1190375 EAMF-A-48C-80G	1781043 EAMD-42-40-20-16X25-U	558031 EAML-48-4-48	
With stepper motor						
EMMS-ST-87-...	EMGA-80-P-G...-SST-87	1190421 EAMM-A-M48-80G	1190375 EAMF-A-48C-80G	1190375 EAMF-A-48C-80G	1190375 EAMF-A-48C-80G	
With integrated drive						
EMCA-ST-67-...	EMGC-60-...	1456614 EAMM-A-M48-60H	1460111 EAMF-A-48C-60G/H	3420022 EAMD-42-40-14-16X25-U	558031 EAML-48-4-48	
EGC-HD-220						
With servo motor						
EMMS-AS-100-...	EMGA-120-P-G...-SAS-100	1190774 EAMM-A-M80-120G	1190702 EAMF-A-80A-120G	1781045 EAMD-56-46-25-23X27-U	1209006 EAML-80-6-80	
EMMS-AS-140-...	EMGA-120-P-G...-SAS-140	1190774 EAMM-A-M80-120G	1190702 EAMF-A-80A-120G	1781045 EAMD-56-46-25-23X27-U	1209006 EAML-80-6-80	

1) The input torque must not exceed the maximum permissible transferable torque of the axial kit.

Toothed belt axes EGC-HD-TB, with heavy-duty guide

Accessories

Profile mounting MUE
(order code M)

Materials:
Anodised aluminium
RoHS-compliant

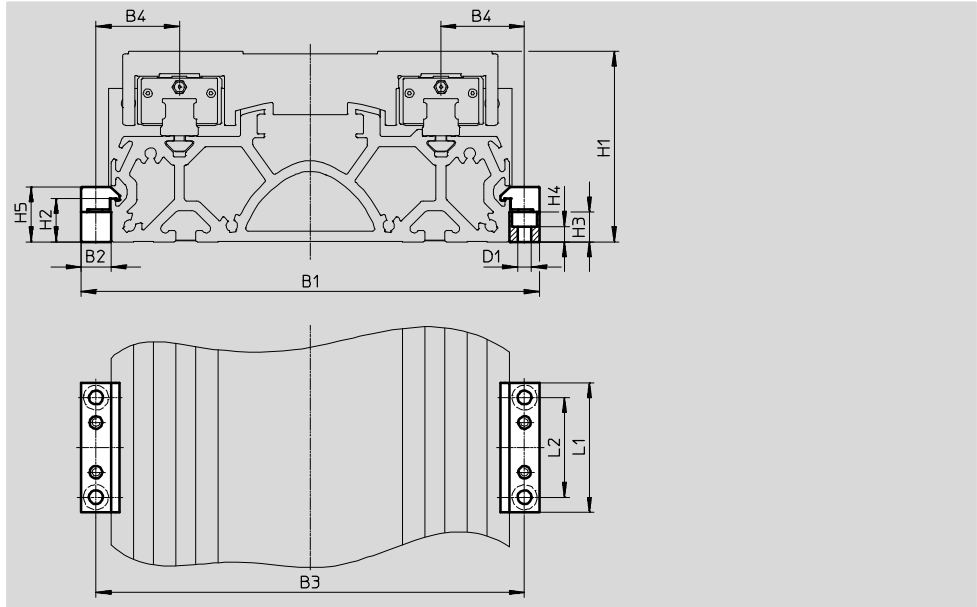

Dimensions and ordering data								
For size	B1	B2	B3	B4	D1 Ø	H1	H2	H3
125	146	12	134	27	5.5	64	17.5	12
160	184	12	172	33.5	5.5	76.5	17.5	12
220	258	19	239	49.5	9	111.5	16	14

For size	H4	H5	L1	L2	Weight [g]	Part No.	Type
125	6.2	22	52	40	80	558043	MUE-70/80
160	6.2	22	52	40	80	558043	MUE-70/80
220	5.5	29.5	90	40	290	558044	MUE-120/185

Toothed belt axes EGC-HD-TB, with heavy-duty guide

Accessories



Shock absorber retainer, retainer EAYH

Emergency buffer NPE → 28
Shock absorber YSRW → 28
(order code A or C)

Materials:
Anodised aluminium
RoHS-compliant

Cannot be used in combination with
the variants GP.

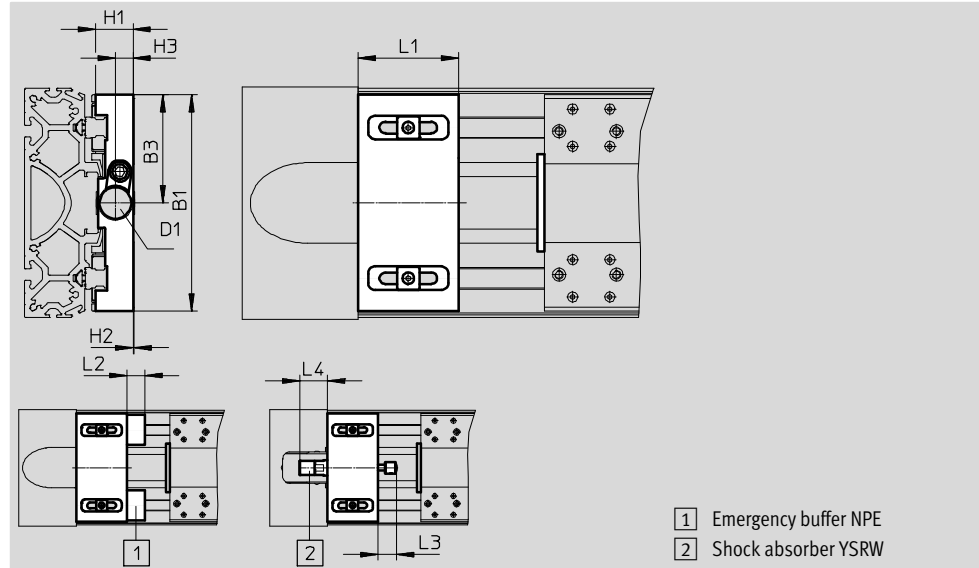
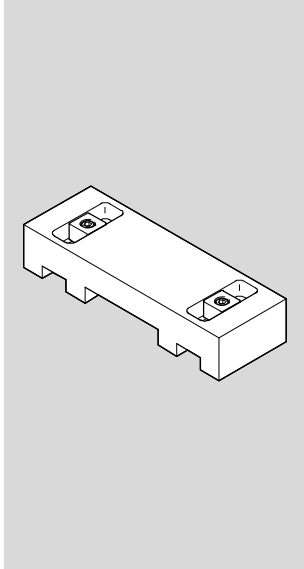

Dimensions and ordering data													
For size	B1	B3	D1	H1	H2	H3	L1	L2	L3	L4 Min.	Weight [g]	Part No.	Type
Shock absorber retainer													
125	120	60	M16x1	19.8	0.4	9.7	50	-	20	36	286	1653251	EAYH-L2-125
160	150.7	75.3	M22x1.5	26.2	0.8	12.3	70	-	26	38.5	622	1653250	EAYH-L2-160
220	204	102	M26x1.5	38.7	0.1	15	70	-	34	63.5	1218	1653253	EAYH-L2-220
Retainer for emergency buffer													
125	120	-	-	19.8	0.4	-	50	17	-	-	260	1662803	EAYH-L2-125-N
160	150.7	-	-	26.2	0.8	-	70	25	-	-	617	1669259	EAYH-L2-160-N
220	204	-	-	38.7	0.1	-	70	30	-	-	1195	1669260	EAYH-L2-220-N

Switch lug SF-EGC-HD-1

For sensing via proximity sensor
SIES-8M
(order code X or Z)

Materials:
Galvanised steel
RoHS-compliant

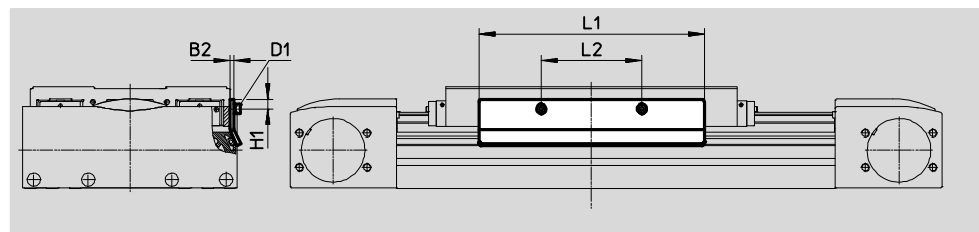

Dimensions and ordering data								
For size	B2	D1	H1	L1	L2	Weight [g]	Part No.	Type
125	2	M4x8	7.8	150	56	70	570027	SF-EGC-HD-1-125
160	3	M4x8	7.3	170	76	160	1645872	SF-EGC-HD-1-160
220	3	M5x10	11.5	250	140	310	1645866	SF-EGC-HD-1-220

Toothed belt axes EGC-HD-TB, with heavy-duty guide

Accessories

Switch lug SF-EGC-HD-2

For sensing via proximity sensor
SIEN-M8B (order code O, P, W or R) or
SIES-8M (order code X or Z)

Materials:

Galvanised steel
RoHS-compliant



Sensor bracket HWS-EGC

For proximity sensor SIEN-M8B
(order code O, P, W or R)

Materials:

Galvanised steel
RoHS-compliant

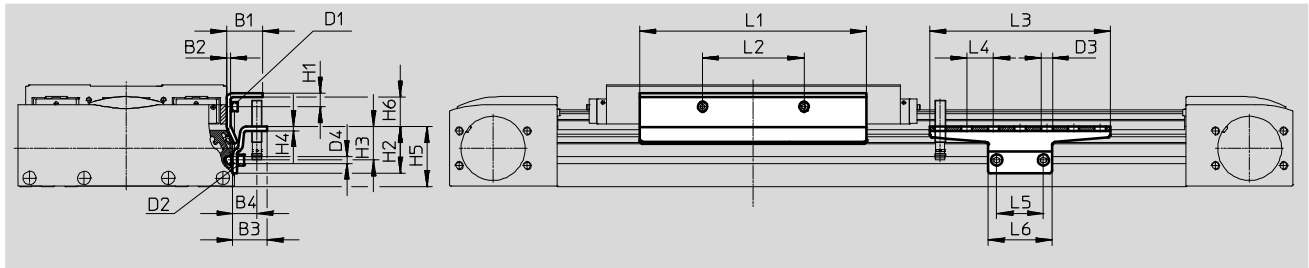

Dimensions and ordering data										
For size	B1	B2	B3	B4	D1	D2	D3 Ø	D4 Ø	H1	H2
125	24	2	25.5	18	M4x8	M5x8	8.4	5.2	9	35
160	27	3	25.5	18	M4x8	M5x8	8.4	5.2	10.3	35
220	31	3	25.5	18	M5x10	M5x14	8.4	5.2	11.5	65

For size	H3	H4	H5	H6	L1	L2	L3	L4	L5	L6
125	25	3	45	14	150	56	135	20	35	48
160	25	3	45	22.2	170	76	135	20	35	48
220	55	3	75	18.4	250	140	215	20	35	48





For size	Weight [g]	Part No.	Type
Switch lug			
125	122	570030	SF-EGC-HD-2-125
160	261	1645865	SF-EGC-HD-2-160
220	430	1645868	SF-EGC-HD-2-220

For size	Weight [g]	Part No.	Type
Sensor bracket			
125	110	558057	HWS-EGC-M5
160	110	558057	HWS-EGC-M5
220	217	570365	HWS-EGC-M8-B

Toothed belt axes EGC-HD-TB, with heavy-duty guide

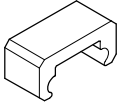
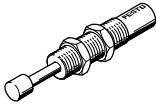
FESTO

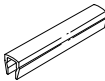
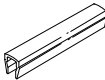
Accessories

Ordering data						
	For size	Comment	Order code	Part No.	Type	PU ¹⁾
Emergency buffer NPE						
	125	Use in combination with retainer EAYH	A	1662475	NPE-125	1
	160			1672593	NPE-160	
	220			1672598	NPE-220	
Shock absorber YSRW Technical data → Internet: ysrw						
	125	Use in combination with shock absorber retainer EAYH	C	191196	YSRW-12-20	1
	160			191197	YSRW-16-26	
	220			191198	YSRW-20-34	
Slot nut NST						
	125, 160 ³⁾	For mounting slot	Y	150914	NST-5-M5	1
				8047843	NST-5-M5-10	10
				8047878	NST-5-M5-50	50
	160 ⁴⁾ , 220	For mounting slot	Y	150915	NST-8-M6	1
				8047868	NST-8-M6-10	10
8047869	NST-8-M6-50	50				
Centring pin/sleeve ZBS/ZBH²⁾						
	125	For slide	-	150928	ZBS-5	10
	125 ... 220			150927	ZBH-9	
Slot cover ABP						
	125, 160 ³⁾	For mounting slot Every 0.5 m	B	151681	ABP-5	2
	160 ⁴⁾ , 220			151682	ABP-8	
Slot cover ABP-S						
	125 ... 220	For sensor slot Every 0.5 m	S	563360	ABP-5-S1	2
Clip SMBK						
	125 ... 220	For sensor slot, for attaching the proximity sensor cables	CL	534254	SMBK-8	10

- 1) Packaging unit quantity
- 2) 2 centring pins/sleeves included in the scope of delivery of the axis
- 3) For mounting slot at side
- 4) For mounting slot underneath

Toothed belt axes EGC-HD-TB, with heavy-duty guide

Accessories



Mounting options between axis and support profile

Depending on the adapter kit, the spacing between the axis and the support profile is:
x = 20 mm or 50 mm

The support profile must be mounted using at least 2 adapter kits. For longer strokes, an adapter kit must be used every 500 mm.

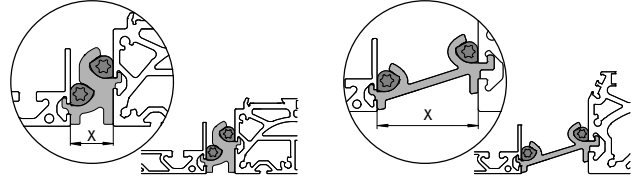
Example:

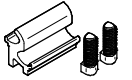

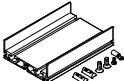
Ordering data					
	For size	Comment	Part No.	Type	PU ¹⁾
Adapter kit DHAM					
	160	<ul style="list-style-type: none"> For mounting the support profile on the axis Spacing between axis and profile is 20 mm 	562241	DHAM-ME-N1-CL	1
	220		562242	DHAM-ME-N2-CL	
	125, 160	<ul style="list-style-type: none"> For mounting the support profile on the axis Spacing between axis and profile is 50 mm 	574560	DHAM-ME-N1-50-CL	
	220		574561	DHAM-ME-N2-50-CL	
Support profile HMIA					
	70 ... 120	<ul style="list-style-type: none"> For guiding an energy chain 	539379	HMIA-E07-	1



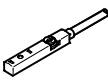
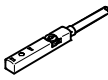

1) Packaging unit quantity



Ordering data – Proximity sensor for T-slot, inductive							Technical data → Internet: sies	
	Type of mounting	Electrical connection	Switching output	Cable length [m]	Order code	Part No.	Type	
N/O contact								
	Insertable in the slot from above, flush with the cylinder profile	Cable, 3-wire	PNP	7.5	X	551386	SIES-8M-PS-24V-K-7,5-OE	
		Plug connector M8x1, 3-pin		0.3	–	551387	SIES-8M-PS-24V-K-0,3-M8D	
		Cable, 3-wire	NPN	7.5	–	551396	SIES-8M-NS-24V-K-7,5-OE	
		Plug connector M8x1, 3-pin		0.3	–	551397	SIES-8M-NS-24V-K-0,3-M8D	
N/C contact								
	Insertable in the slot from above, flush with the cylinder profile	Cable, 3-wire	PNP	7.5	Z	551391	SIES-8M-PO-24V-K-7,5-OE	
		Plug connector M8x1, 3-pin		0.3	–	551392	SIES-8M-PO-24V-K-0,3-M8D	
		Cable, 3-wire	NPN	7.5	–	551401	SIES-8M-NO-24V-K-7,5-OE	
		Plug connector M8x1, 3-pin		0.3	–	551402	SIES-8M-NO-24V-K-0,3-M8D	

Toothed belt axes EGC-HD-TB, with heavy-duty guide



Accessories

Ordering data – Proximity sensors M8 (round design), inductive						Technical data → Internet: sien	
	Electrical connection	LED	Switching output	Cable length [m]	Order code	Part No.	Type
N/O contact							
	Cable, 3-wire	■	PNP	2.5	O	150386	SIEN-M8B-PS-K-L
	Plug connector M8x1, 3-pin	■	PNP	–	W	150387	SIEN-M8B-PS-S-L
N/C contact							
	Cable, 3-wire	■	PNP	2.5	P	150390	SIEN-M8B-PO-K-L
	Plug connector M8x1, 3-pin	■	PNP	–	R	150391	SIEN-M8B-PO-S-L

Ordering data – Connecting cables				Technical data → Internet: nebu	
	Electrical connection, left	Electrical connection, right	Cable length [m]	Part No.	Type
	Straight socket, M8x1, 3-pin	Cable, open end, 3-wire	2.5	159420	SIM-M8-3GD-2,5-PU
			2.5	541333	NEBU-M8G3-K-2.5-LE3
			5	541334	NEBU-M8G3-K-5-LE3
	Angled socket, M8x1, 3-pin	Cable, open end, 3-wire	2.5	541338	NEBU-M8W3-K-2.5-LE3
			5	541341	NEBU-M8W3-K-5-LE3

Product Range and Company Overview

A Complete Suite and Company Overview

Our experienced engineers provide complete support at every stage of your development process, including: conceptualization, analysis, engineering, design, assembly, documentation, validation, and production.



Custom Automation Components
Complete custom engineered solutions



Custom Control Cabinets
Comprehensive engineering support and on-site services



Complete Systems
Shipment, stocking and storage services

The Broadest Range of Automation Components

With a comprehensive line of more than 30,000 automation components, Festo is capable of solving the most complex automation requirements.



Electromechanical
Electromechanical actuators, motors, controllers & drivers



Pneumatics
Pneumatic linear and rotary actuators, valves, and air supply



PLCs and I/O Devices
PLC's, operator interfaces, sensors and I/O devices

Supporting Advanced Automation... As No One Else Can!

Festo is a leading global manufacturer of pneumatic and electromechanical systems, components and controls for industrial automation, with more than 16,000 employees in 60 national headquarters serving more than 180 countries. For more than 80 years, Festo has continuously elevated the state of manufacturing with innovations and optimized motion control solutions that deliver higher performing, more profitable automated manufacturing and processing equipment. Our dedication to the advancement of automation extends beyond technology to the education and development of current and future automation and robotics designers with simulation tools, teaching programs, and on-site services.

Quality Assurance, ISO 9001 and ISO 14001 Certifications

Festo Corporation is committed to supply all Festo products and services that will meet or exceed our customers' requirements in product quality, delivery, customer service and satisfaction.

To meet this commitment, we strive to ensure a consistent, integrated, and systematic approach to management that will meet or exceed the requirements of the ISO 9001 standard for Quality Management and the ISO 14001 standard for Environmental Management.



© Copyright 2013, Festo Corporation. While every effort is made to ensure that all dimensions and specifications are correct, Festo cannot guarantee that publications are completely free of any error, in particular typing or printing errors. Accordingly, Festo cannot be held responsible for the same. For Liability and Warranty conditions, refer to our "Terms and Conditions of Sale", available from your local Festo office. All rights reserved. No part of this publication may be reproduced, distributed, or transmitted in any form or by any means, electronic, mechanical, photocopying or otherwise, without the prior written permission of Festo. All technical data subject to change according to technical update.



Printed on recycled paper at New Horizon Graphic, Inc., FSC certified as an environmental friendly printing plant.

Festo North America

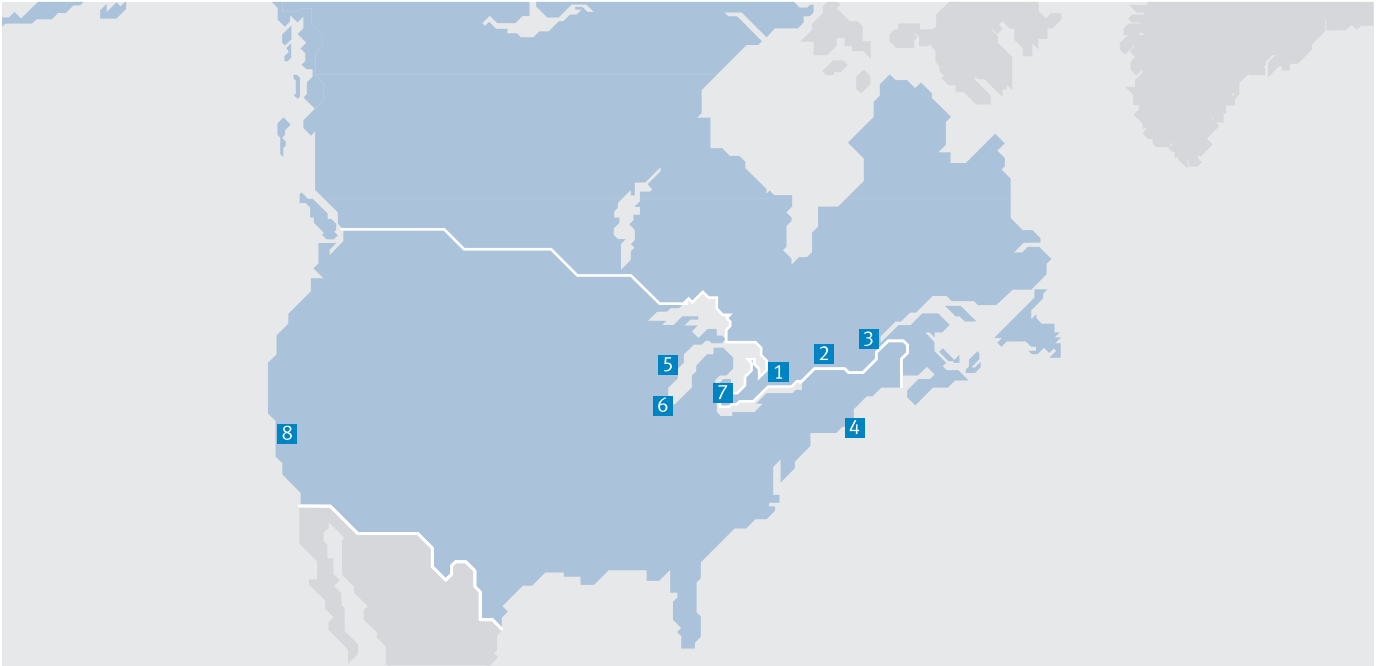

**1 Festo Canada
Headquarters
Festo Inc.**
5300 Explorer Drive
Mississauga, ON
L4W 5G4

2 Montréal
5600, Trans-Canada
Pointe-Claire, QC
H9R 1B6

3 Québec City
2930, rue Watt#117
Québec, QC
G1X 4G3



**4 Festo United States
Headquarters
Festo Corporation**
395 Moreland Road
Hauppauge, NY
11788

5 Appleton
North 922 Tower View Drive, Suite N
Greenville, WI
54942

7 Detroit
1441 West Long Lake Road
Troy, MI
48098

6 Chicago
85 W Algonquin - Suite 340
Arlington Heights, IL
60005

8 Silicon Valley
4935 Southfront Road, Suite F
Livermore, CA
94550

Festo Regional Contact Center

Canadian Customers

Commercial Support:
Tel: 1 877 GO FESTO (1 877 463 3786)
Fax: 1 877 FX FESTO (1 877 393 3786)
Email: festo.canada@ca.festo.com

Technical Support:
Tel: 1 866 GO FESTO (1 866 463 3786)
Fax: 1 877 FX FESTO (1 877 393 3786)
Email: technical.support@ca.festo.com

USA Customers

Commercial Support:
Tel: 1 800 99 FESTO (1 800 993 3786)
Fax: 1 800 96 FESTO (1 800 963 3786)
Email: customer.service@us.festo.com

Technical Support:
Tel: 1 866 GO FESTO (1 866 463 3786)
Fax: 1 800 96 FESTO (1 800 963 3786)
Email: product.support@us.festo.com