

Passive guide axes EGC-FA, without drive



Passive guide axes EGC-FA, without drive

Key features

At a glance

- Driveless linear guide units with guide and freely movable slide
- The passive guide axis is designed to support force and torque capacity in multi-axis applications
- Higher torsional resistance
- Reduced vibrations with dynamic loads
- Drive axis and passive guide axis can be placed adjacent to or above one another

System product for handling and assembly technology

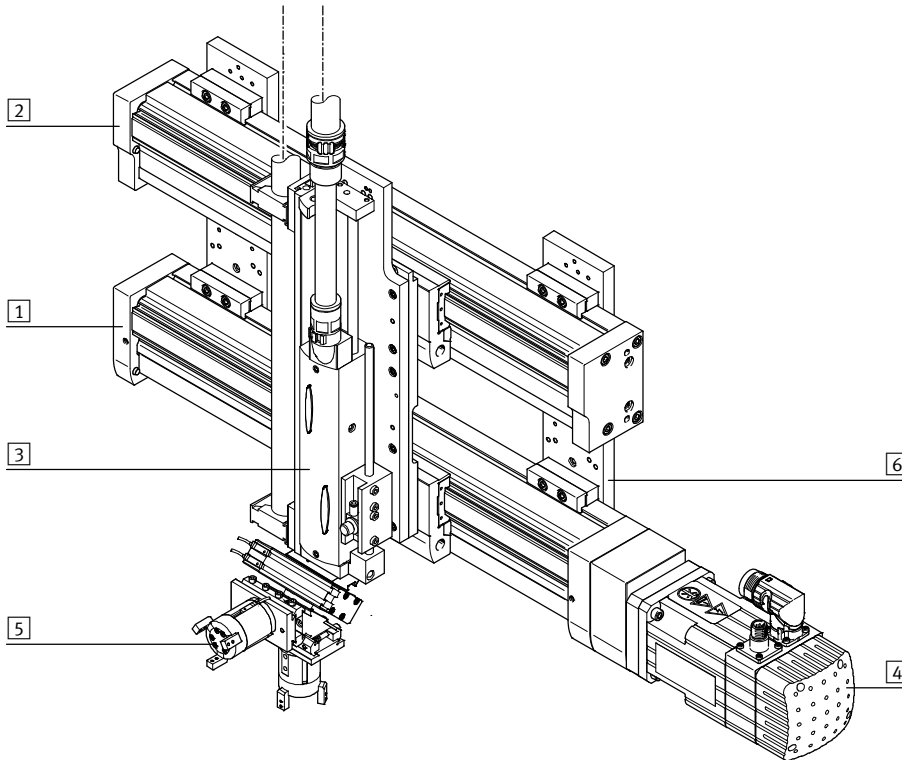

| System components and accessories | | |
|-----------------------------------|--------------------|-------------------------------------------------------------------------------------------|
| Type/Order code | Description | → Page/Internet |
| 1 | Axes | Wide range of combinations possible within handling and assembly technology axis |
| 2 | Passive guide axes | For supporting force and torque capacity in multi-axis applications passive guide axis |
| 3 | Drives | Wide range of combinations possible within handling and assembly technology drive |
| 4 | Motors | Servo and stepper motors, with or without gear unit motor |
| 5 | Grippers | Wide range of variations possible within handling and assembly technology gripper |
| 6 | Adapters | For drive/drive and drive/gripper connections adapter kit |

Passive guide axes EGC-FA, without drive

Key features

Slide variants

Standard slide



Additional slide



Guide options

Protected version

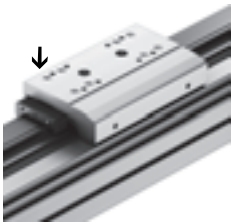

- The protected guide cleans the guide rail and protects the recirculating ball bearing guide with the aid of an additional wiper

With central lubrication

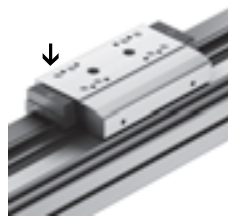

- The lubrication adapter enables the guide to be permanently lubricated using semi or fully automatic relubrication devices
- The adapters are suitable for oils and greases
- Both lubrication adapters must be connected

Clamping unit

→ 9

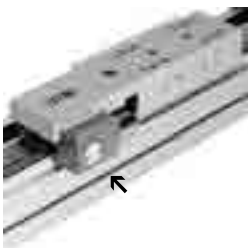

- 1 or 2-channel design, for holding loads
- Reliable holding is guaranteed since the forces act directly on the slide
- A limited number of emergency braking operations are permissible with the sizes 120 and 185

Guide axes and the corresponding axes/drives

Passive guide axis ELFA-RF



- Can be combined with:
 - Toothed belt axis ELGA-TB-RF
- For size 70, 80
- Load capacity to max. 800 N or 180 Nm

Passive guide axis DGC-FA



- Can be combined with:
 - Linear drive DGC-KF
- For size 8 ... 63
- Load capacity to max. 15200 N or 1157 Nm

Passive guide axis EGC-FA



- Can be combined with:
 - Toothed belt axis EGC-TB
 - Spindle axis EGC-BS
- For size 70 ... 185
- Load capacity to max. 15200 N or 1157 Nm

Passive guide axis FDG-ZR-RF



- Can be combined with:
 - Toothed belt axis DGE-ZR-KF
- For size 25 ... 63
- Load capacity to max. 600 N or 600 Nm

Passive guide axis FDG-ZR/-SP



- Can be combined with:
 - Toothed belt axis DGE-ZR-KF
 - Spindle axis DGE-SP-KF
- For size 18 ... 63
- Load capacity to max. 14050 N or 1820 Nm

Passive guide axes EGC-FA, without drive

Type codes

| | | | | | | | | | | | |
|-----------------------|---------------------------|---|----|---|-----|---|----|---|--|---|----|
| | EGC | - | 70 | - | 500 | - | FA | - | | - | GK |
| Type | | | | | | | | | | | |
| EGC | Passive guide axis | | | | | | | | | | |
| Size | | | | | | | | | | | |
| Stroke [mm] | | | | | | | | | | | |
| Guide | | | | | | | | | | | |
| FA | Passive guide axis | | | | | | | | | | |
| Stroke reserve | | | | | | | | | | | |
| Slide | | | | | | | | | | | |
| GK | Standard slide | | | | | | | | | | |
| GP | Standard slide, protected | | | | | | | | | | |

Passive guide axes EGC-FA, without drive

Type codes



[] - [] - [] - [] ZUB - F2MX2Z - DN

Additional slide

| | |
|------|--------|
| ...K | 1 to 2 |
|------|--------|

Lubrication function

| | |
|---|---------------------|
| - | Standard |
| C | Lubrication adapter |

Clamping unit

| | |
|-----|------------------|
| 1HL | 1-channel, left |
| 1HR | 1-channel, right |
| 2H | 2-channel |

Actuation type

| | |
|----|------------------------|
| PN | Pneumatically actuated |
|----|------------------------|

Accessories enclosed separately

| | |
|-------|--------------------------------------------------------------------------------|
| F | Foot mounting |
| ...M | Profile mounting |
| ...B | Mounting slot cover |
| ...S | Sensor slot cover |
| ...Y | Slot nut for mounting slot |
| ...X | Proximity sensor (SIES), inductive, slot type 8, PNP, N/O contact, 7.5 m cable |
| ...Z | Proximity sensor (SIES), inductive, slot type 8, PNP, N/C contact, 7.5 m cable |
| ...A | Emergency buffer with retainer |
| ...C | Shock absorber with retainer |
| ...O | Proximity sensor (SIEN), inductive, M8, PNP, N/O contact, 2.5 m cable |
| ...P | Proximity sensor (SIEN), inductive, M8, PNP, N/C contact, 2.5 m cable |
| ...W | Proximity sensor (SIEN), inductive, M8, PNP, N/O contact, plug M8 |
| ...R | Proximity sensor (SIEN), inductive, M8, PNP, N/C contact, plug M8 |
| ...V | Connecting cable |
| ...CL | Cable clip |

Operating instructions

| | |
|----|------|
| DN | None |
|----|------|

Passive guide axes EGC-FA, without drive

Peripherals overview

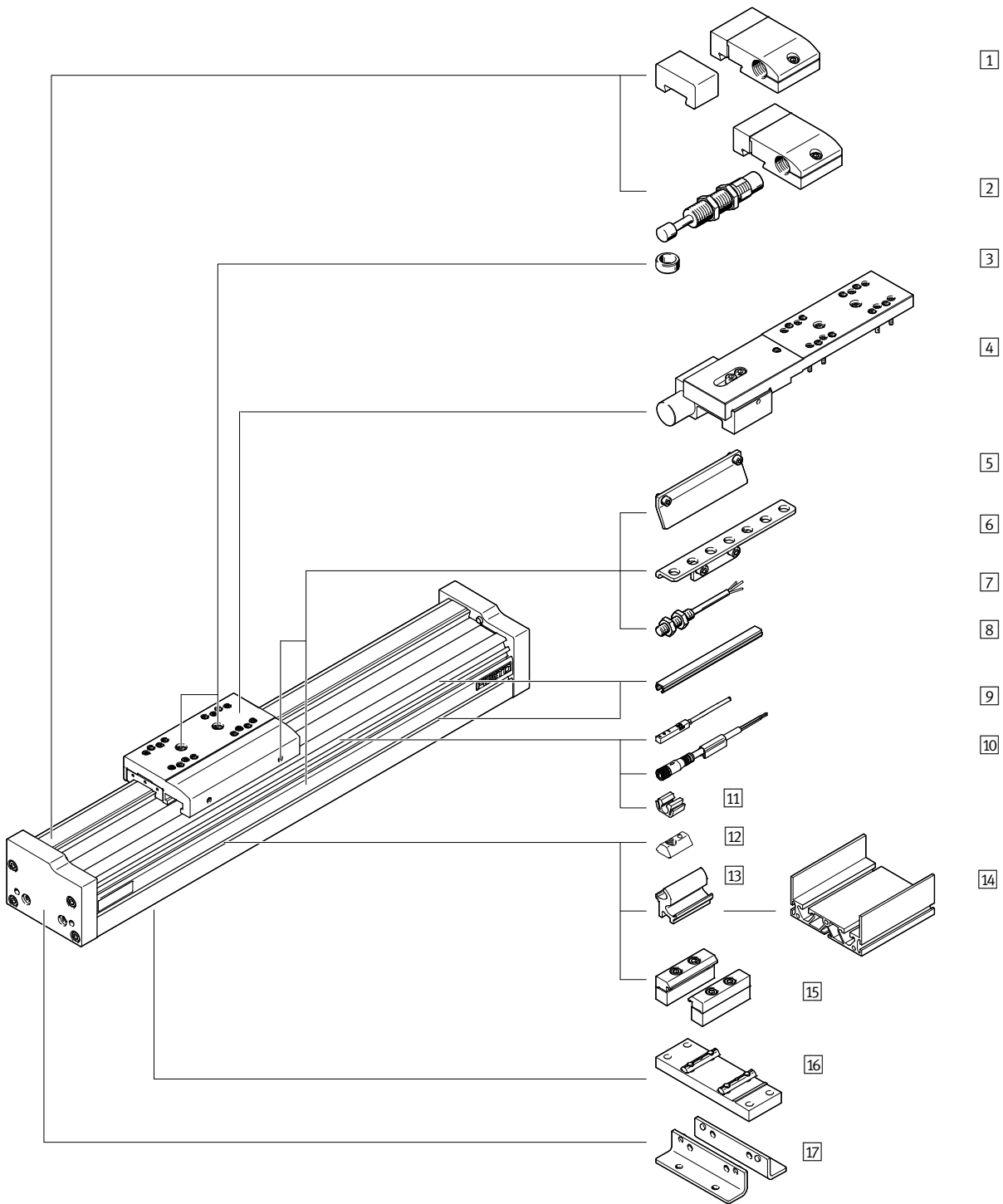

Passive guide axes EGC-FA, without drive

Peripherals overview



| Variants and accessories | | |
|-----------------------------------------|---------------------------------------------------------------------------------------------------------------------------------------------------------------------------------------------------------|-----------------|
| Type/Order code | Description | → Page/Internet |
| 1 Emergency buffer with retainer A | For avoiding damage at the end stop in the event of malfunction | 31 |
| 2 Shock absorber with retainer C | For avoiding damage at the end stop in the event of malfunction | 31 |
| 3 Centring pin/sleeve ZBS, ZBH | <ul style="list-style-type: none"> For centring loads and attachments on the slide 2 centring pins/sleeves included in the scope of delivery of the axis | 33 |
| 4 Clamping unit 1H...-PN, 2H-PN | For holding loads | 9 |
| 5 Switch lug X, Z, O, P, W, R | For sensing the slide position | 31 |
| 6 Sensor bracket O, P, W, R | Adapter for mounting the inductive proximity sensors (round design) on the axis | 32 |
| 7 Proximity sensor, M8 O, P, W, R | <ul style="list-style-type: none"> Inductive proximity sensor, round design The order code O, P, W, R includes 1 switch lug and max. 2 sensor brackets in the scope of delivery | 35 |
| 8 Slot cover B, S | <ul style="list-style-type: none"> For protecting against the ingress of dirt | 33 |
| 9 Proximity sensor, slot type 8 X, Z | <ul style="list-style-type: none"> Inductive proximity sensor, for slot type 8 The order code X, Z includes 1 switch lug in the scope of delivery | 34 |
| 10 Plug socket with cable V | For proximity sensor (order code W and R) | 35 |
| 11 Clip CL | For mounting the proximity sensor cable in the slot | 33 |
| 12 Slot nut Y | For mounting attachments | 33 |
| 13 Adapter kit DHAM | For mounting the support profile on the axis | 34 |
| 14 Support profile HMIA | For mounting and guiding an energy chain | 34 |
| 15 Profile mounting M | For mounting the axis at the side of the profile | 29 |
| 16 Central support EAHF | For mounting the axis at the bottom of the profile | 30 |
| 17 Foot mounting F | For mounting the axis on the end cap | 28 |

Passive guide axes EGC-FA, without drive

Technical data

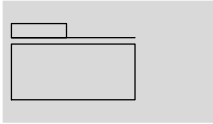
Function



-  - Size
70 ... 185
-  - Stroke length
50 ... 8500 mm
-  - www.festo.com



| General technical data | | | | | |
|------------------------|---------------------|----------------------------------|-------------|-------------|-------------|
| Size | | 70 | 80 | 120 | 185 |
| Design | | Passive axis | | | |
| Guide | | Recirculating ball bearing guide | | | |
| Mounting position | | Any | | | |
| Working stroke | | | | | |
| EGC-...-GK/-GP | [mm] | 50 ... 5000 | 50 ... 8500 | 50 ... 8500 | 50 ... 8500 |
| Max. speed | [m/s] | 5 | | | |
| Max. acceleration | [m/s ²] | 50 | | | |

| Operating and environmental conditions | | |
|----------------------------------------|------|-------------|
| Ambient temperature | [°C] | -10 ... +60 |
| Protection class | | IP40 |

| Weight [kg] | | | | | |
|---------------------------------------------|--|-------|-------|--------|--------|
| Size | | 70 | 80 | 120 | 185 |
| Basic weight with 0 mm stroke ¹⁾ | | | | | |
| EGC-...-GK/-GP | | 1,200 | 2,000 | 7,300 | 20,800 |
| Additional weight per 1,000 mm stroke | | 4,200 | 6,200 | 15,000 | 29,000 |
| Moving load | | | | | |
| EGC-...-GK/-GP | | 0,300 | 0,550 | 2,000 | 6,000 |
| Additional slide | | | | | |
| EGC-...-K | | 0,300 | 0,550 | 2,000 | 6,000 |
| Clamping unit | | | | | |
| EGC-...-1H...-PN | | - | 0,700 | 2,300 | 4,900 |
| EGC-...-2H-PN | | - | 1,300 | 4,000 | 8,300 |

1) Incl. slide

Passive guide axes EGC-FA, without drive

Technical data

Materials

Sectional view

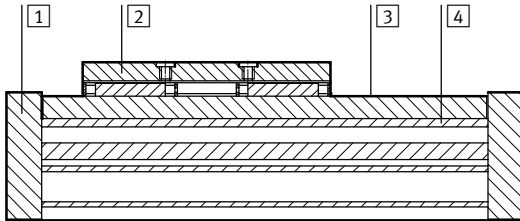

| Axis | |
|-----------------------------------------------------|---------------------------------------------|
| 1 | End cap Anodised wrought aluminium alloy |
| 2 | Slide Anodised wrought aluminium alloy |
| 3 | Guide rail High-alloy steel |
| 4 | Profile Anodised wrought aluminium alloy |
| Note on materials | |
| RoHS-compliant | |
| Contains PWIS (paint-wetting impairment substances) | |

| Technical data – Clamping unit | | | Dimensions → 20 | |
|-----------------------------------------------------------|----------------------------|--------------------------------------------------------|-----------------|-----------|
| Size | | 80 | 120 | 185 |
| Pneumatic connection | | M5 | M5 | M5 |
| Clamping type | | Clamping via spring force, released via compressed air | | |
| Static holding force | | | | |
| EGC-...-1H...-PN | [N] | 320 | 1200 | 1500 |
| EGC-...-2H-PN | [N] | 640 | 2400 | 3000 |
| Max. number of emergency braking operations ¹⁾ | [[]] | – | 750 35 | 750 70 |
| at reference energy | | | | |
| Number of clamping operations under nominal load | [million switching cycles] | 0.45 | 0.05 | > 1.4 |

1) Emergency braking refers to braking the effective load if the drive axis loses power.

| Operating and environmental conditions – Clamping unit | | |
|--------------------------------------------------------|-------|-----------------------------------------------------|
| Operating medium | | Compressed air according to ISO 8573-1:2010 [7:4:4] |
| Operating pressure | | |
| Clamping unit opened | [bar] | 4.5 ... 8 |
| Clamping unit closed | [bar] | Pressureless |
| Ambient temperature | [°C] | –10 ... +60 |

Passive guide axes EGC-FA, without drive

Technical data



Characteristic load values

The indicated forces and torques refer to the slide surface. The point of application of force is the point where the centre of the guide and the longitudinal centre of the slide intersect.

These values must not be exceeded during dynamic operation. Special attention must be paid to the cushioning phase.

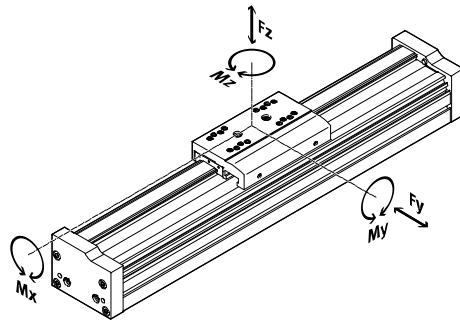

If the axis is subjected to more than two of the indicated forces and torques simultaneously, the following equation must be satisfied in addition to the indicated maximum loads:

Calculating the load comparison factor:

$$f_v = \frac{|F_{y,dyn}|}{F_{y,max}} + \frac{|F_{z,dyn}|}{F_{z,max}} + \frac{|M_{x,dyn}|}{M_{x,max}} + \frac{|M_{y,dyn}|}{M_{y,max}} + \frac{|M_{z,dyn}|}{M_{z,max}}$$

| Permissible forces and torques | | | | | |
|--------------------------------|------------|------|------|------|-------|
| Size | | 70 | 80 | 120 | 185 |
| F _{y,max.} | [N] | 1850 | 3050 | 6890 | 15200 |
| F _{z,max.} | [N] | 1850 | 3050 | 6890 | 15200 |
| M _{x,max.} | [Nm] | 16 | 36 | 144 | 529 |
| M _{y,max.} | GK/GP [Nm] | 51 | 97 | 380 | 1157 |
| M _{z,max.} | GK/GP [Nm] | 51 | 97 | 380 | 1157 |

Service life

The service life of the guide depends on the load. To provide a rough indication of the service life of the guide,

the graph below plots the load comparison factor f_v against the service life.

These values are only theoretical. You must consult your local contact person at Festo for load comparison factors f_v greater than 1.5.

Load comparison factor f_v as a function of service life

Example:

A user wants to move an X kg load. Using the above formula gives a value of 1.5 for the load comparison factor. According to the graph, the guide has a service life of approx.

1500 km. Reducing the acceleration reduces the M_z and M_y values. A load comparison factor of 1 now gives a service life of 5000 km.

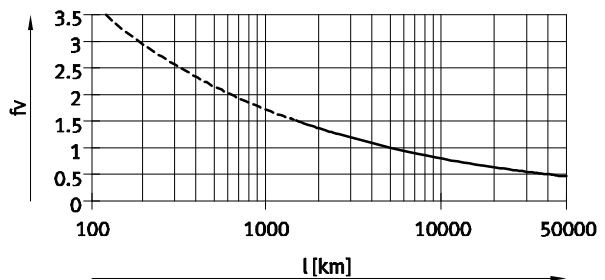

- - Note

PositioningDrives
sizing software
www.festo.com

The guide workload for a service life of 5000 km can be calculated with the help of the sizing software.

$f_v > 1.5$ are only theoretical comparison values for the recirculating ball bearing guide.

Passive guide axes EGC-FA, without drive

Technical data

| Stroke reserve | | | |
|--------------------------------------------------------------------------------------------------------------------------------------------------------------------------------------------------------------------------------------------------------------------------------------|-------------------------------------------------------------------------------------------------------------------------------------------------------------------------------------------------------------------------------------------------------------------------------|-----------------------------------------------------------------------------------------------------------------------------------------------------------------------------------------------------------|-----------------------------------------------------------------------------------------------------------------------------------------------------------|
| Stroke length | Stroke reserve | | |
| The selected stroke corresponds in principle to the required working stroke. The variant GK does not have a wiper seal on the guide. This variant therefore additionally has a safety distance between the drive cap and slide that is not designated as part of the working stroke. | A safety distance (similar to GK) between the drive cap and slide can be defined for the variants GP and GK-C using the modular product system via the "stroke reserve" feature. With the variant GK, the stroke reserve and safety distance are added for each end position. | <ul style="list-style-type: none"> The stroke reserve length can be freely selected The sum of the stroke length and 2x stroke reserve must not exceed the maximum working stroke | Example: EGC-70-500-FA-20H-... Working stroke = 500 mm 2x stroke reserve = 40 mm Total length = 540 mm (540 mm = 500 mm + 2x 20 mm) |

| Size | 70 | 80 | 120 | 185 |
|------------------------------------------------------|------|----|-----|-----|
| L9 = safety distance with GK [mm] (per end position) | 10.5 | 13 | 18 | 21 |

Working stroke reduction

With standard slide GK/GP with additional slide K

- With a guide axis with additional slide, the working stroke is reduced by the length of the additional slide and the distance between both slides
- With the variant GP, the additional slide is also protected
- If the variant GK-C is ordered, the additional slide is also supplied with lubrication adapters

L16 = Slide length
 L17 = Additional slide length

L18 = Distance between both slides
 1 Additional slide

Example:
 Type EGC-70-500-FA-...-GK-1K
 Working stroke without additional slide = 500 mm
 L18 = 20 mm
 L16, L17 = 100 mm
 Working stroke with additional slide = 380 mm
 (500 mm - 20 mm - 100 mm)

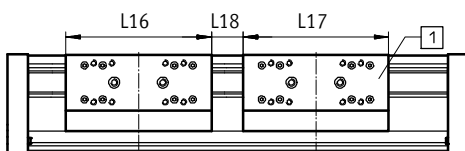

| Dimensions – Additional slide | | | | | | | | | |
|-------------------------------------------|-----|-----|-----|------------|-------|------------|-------|-----|------|
| Size | 70 | | 80 | | 120 | | 185 | | GK-C |
| | GK | GP | GK | GP or GK-C | GK | GP or GK-C | GK | GK | |
| Length L17 [mm] | 100 | 121 | 120 | 146 | 203.3 | 236 | 282.8 | 322 | |
| Min. distance between the slides L18 [mm] | - | 21 | - | 26 | - | 36 | - | 42 | |

Passive guide axes EGC-FA, without drive

Technical data

Working stroke reduction per side

With integrated emergency buffer NPE/shock absorber YSRW with shock absorber retainer KYE

- The working stroke is reduced by the total dimension of the emergency buffer/shock absorber and shock absorber retainer.
- The rubber buffer in the cap must be removed.
- Shock absorbers must not be used in combination with GK-C.

| Size | | 70 | 80 | 120 | 185 |
|-----------------------|------|----|----|-----|-----|
| With emergency buffer | [mm] | 43 | 68 | 98 | 133 |
| With shock absorber | [mm] | 42 | 63 | 84 | 107 |

Working stroke reduction

With integrated clamping unit

- The working stroke is reduced by the length of the clamping unit.
- With 1-channel clamping units, the stroke is reduced on one side with respect to the mounting surface.
- With 2-channel clamping units, the stroke is reduced symmetrically with respect to the mounting surface of the load.
- Shock absorbers must not be used in combination with the clamping unit.

| Size | | 80 | 120 | 185 |
|------------------|------|-----|-----|-----|
| EGC-...-1H...-PN | [mm] | 87 | 124 | 131 |
| EGC-...-2H-PN | [mm] | 174 | 248 | 262 |

2nd moment of area

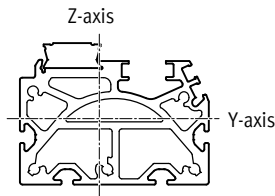

| Size | | 70 | 80 | 120 | 185 |
|-------|--------------------|--------------------|--------------------|--------------------|--------------------|
| I_y | [mm ⁴] | 3.95×10^5 | 8.44×10^5 | 4.62×10^6 | 2.34×10^7 |
| I_z | [mm ⁴] | 5.77×10^5 | 1.16×10^6 | 5.65×10^6 | 2.74×10^7 |

Passive guide axes EGC-FA, without drive

Technical data

Maximum permissible support span L (without profile mounting MUE/central support EAHF) as a function of force F

In order to limit deflection in the case of large strokes, the axis may need to be supported.

The following graphs can be used to determine the maximum permissible support span l as a function of force F acting on the axis. The deflection is $f = 0.5$ mm.

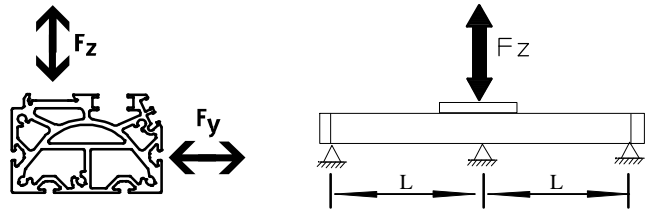

Force Fy

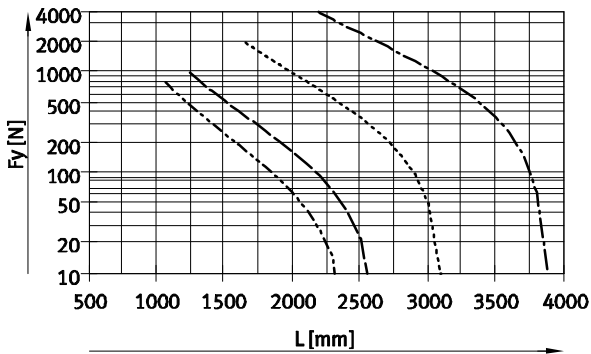

Force Fz

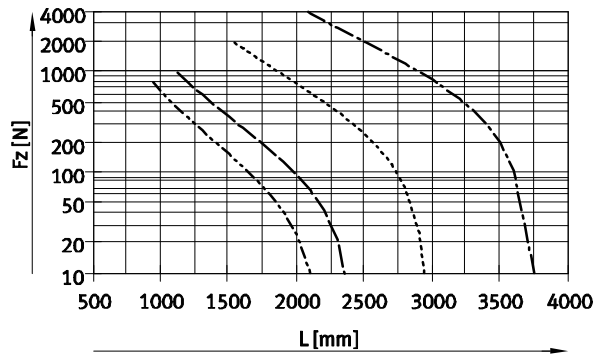

- EGC-70
- EGC-80
- EGC-120
- · - · - EGC-185

Recommended deflection limits

Adherence to the following deflection limits is recommended so as not to impair the functional performance of

the axes. Greater deformation can result in increased friction, greater wear and reduced service life.

| Size | Dyn. deflection (load moving) | Stat. deflection (load stationary) |
|------------|---------------------------------------|------------------------------------|
| 70 ... 185 | 0.05% of the axis length, max. 0.5 mm | 0.1% of the axis length |

Passive guide axes EGC-FA, without drive

Technical data

FESTO

Dimensions

Download CAD data → www.festo.com

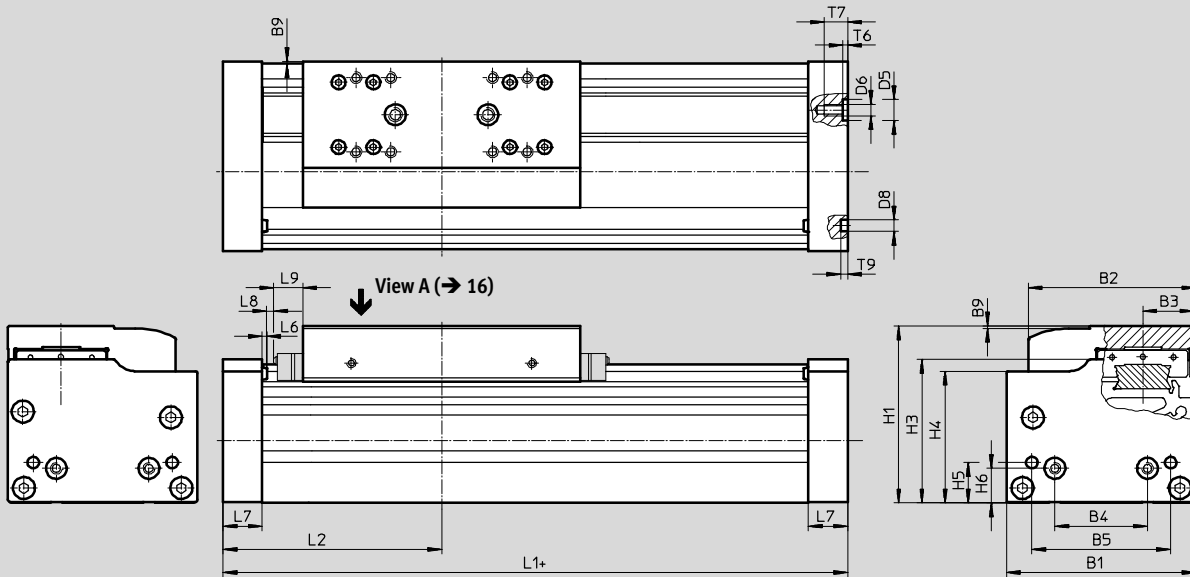

- + = plus stroke length + 2x stroke reserve
- L9 With GK: safety distance per end position
- With GP: dimension for wiper seal → 11
- With GK-C/GV-C: dimension for adapter → 18

| Size | B1 | B2 | B3 | B4 | B5 | B9 | D5 ∅ H7 |
|------|-----|------|------|-----|----|----|---------------|
| 70 | 69 | 58.6 | 16.5 | 30 | 45 | 1 | – |
| 80 | 82 | 72.6 | 22 | 40 | 60 | 1 | 9 |
| 120 | 120 | 107 | 33 | 80 | 40 | 1 | – |
| 185 | 186 | 169 | 53 | 120 | 80 | 1 | – |

| Size | D6 | D8 ∅ H7 | H1 | H3 | H4 | H5 | H6 | L1 |
|------|-----|---------------|-------|------|-------|------|----|-----|
| 70 | M5 | 5 | 64 | 50.5 | 47 | 13 | 13 | 163 |
| 80 | M5 | 5 | 76.5 | 62 | 57 | 17.5 | 15 | 190 |
| 120 | M8 | 9 | 111.5 | 89 | 82 | 22 | 22 | 306 |
| 185 | M10 | 9 | 172.5 | 141 | 131.5 | 25 | 25 | 406 |

| Size | L2 | L6 | L7 | L8 | L9 | T6 | T7 | T9 |
|------|------|-----|----|----|------|-----|------|-----|
| 70 | 81.5 | 1.8 | 16 | 3 | 10.5 | – | 10 | 3.1 |
| 80 | 95 | 2 | 17 | 3 | 13 | 2.1 | 10.1 | 3.1 |
| 120 | 153 | 2 | 30 | 3 | 18 | – | 16 | 2.1 |
| 185 | 203 | 2 | 37 | 3 | 21 | – | 20 | 2.1 |

Passive guide axes EGC-FA, without drive

Technical data

Profile

Size 70

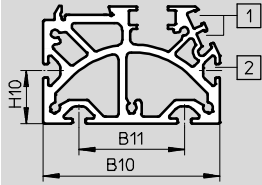

Size 80

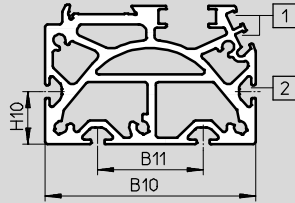

Size 120

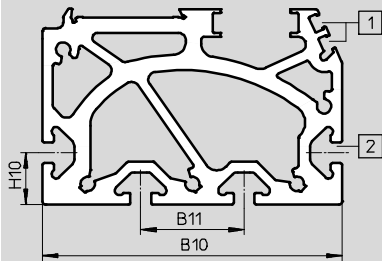

Size 185

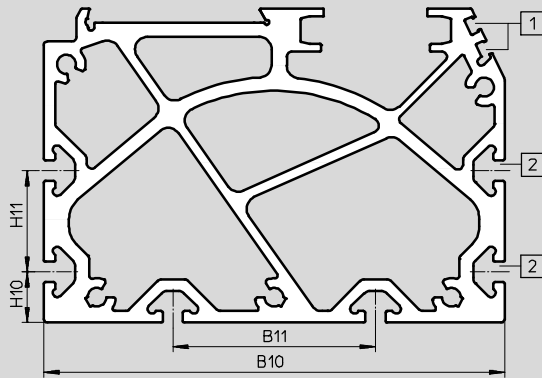

- 1 Sensor slot for proximity sensor
- 2 Mounting slot for slot nut

| Size | B10 | B11 | H10 | H11 |
|------|-----|-----|-----|-----|
| 70 | 67 | 40 | 20 | - |
| 80 | 80 | 40 | 20 | - |
| 120 | 116 | 40 | 20 | - |
| 185 | 182 | 80 | 20 | 40 |

- - Note

Flatness of the bearing surface and the attachments. The use in parallel constructions. → www.festo.com

Passive guide axes EGC-FA, without drive

Technical data

FESTO

Dimensions

Download CAD data → www.festo.com

GK – Standard slide/GP – Standard slide, protected

Size 70

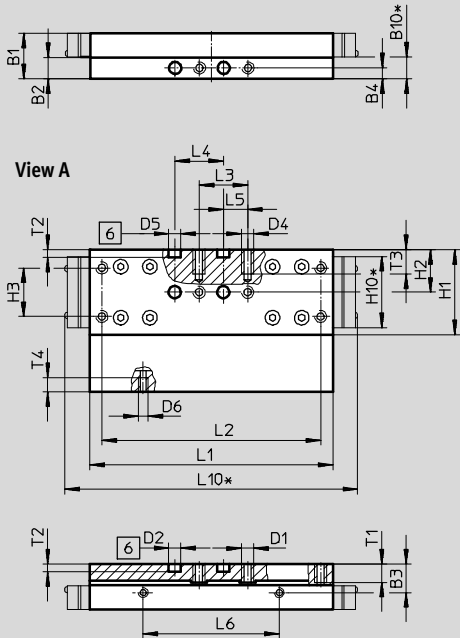

Size 80

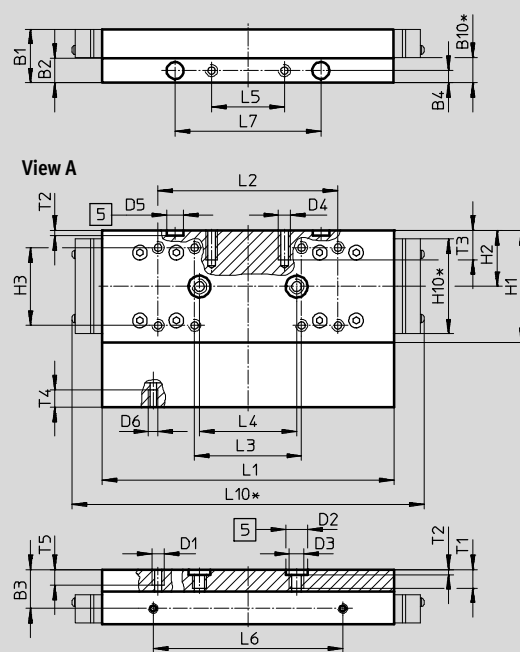

Size 120

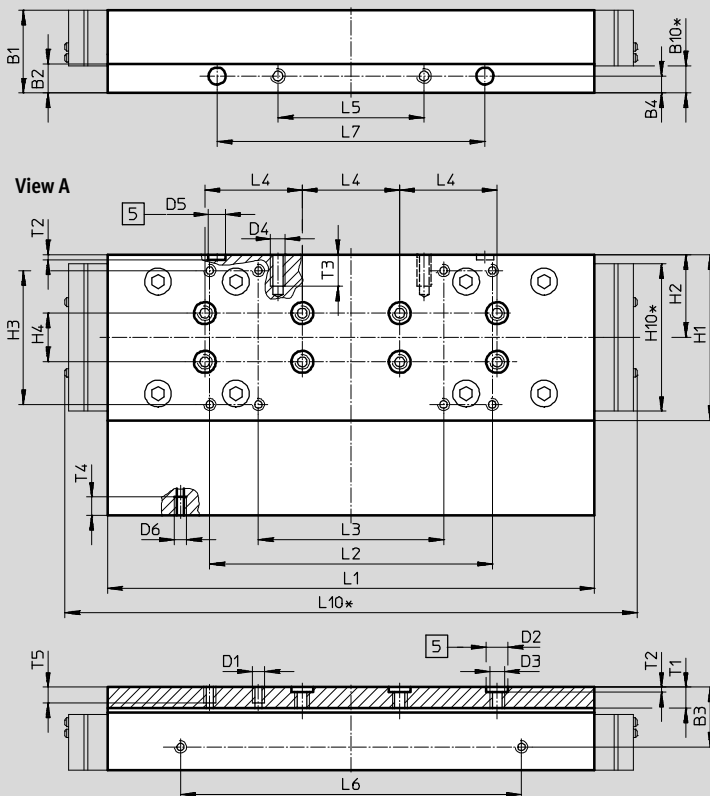

- 5 Hole for centring sleeve
- 6 Hole for centring pin
- * Protected version

Passive guide axes EGC-FA, without drive

Technical data

Dimensions

Download CAD data → www.festo.com

GK – Standard slide

Size 185

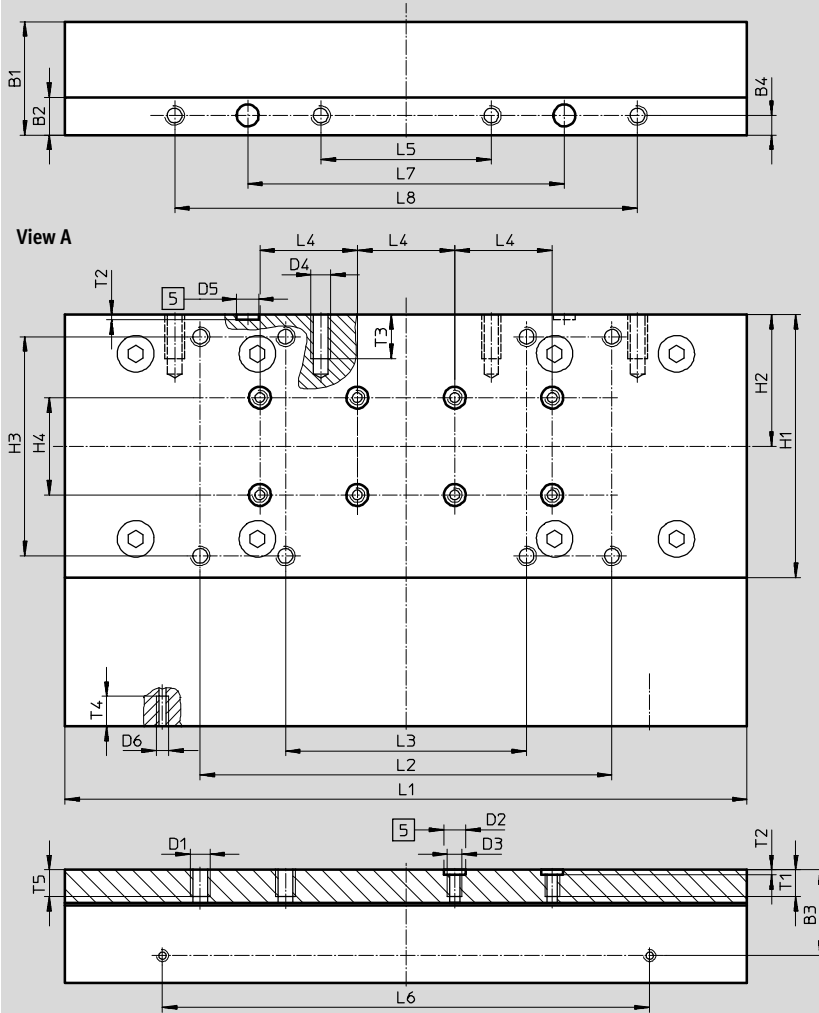

5 Hole for centring sleeve

| Size | B1 | B2 | B3 | B4 | B10* | D1 | D2 ∅ H7 | D3 | D4 | D5 ∅ H7 | D6 | H1 | H2 | H3 | H4 ±0.03 |
|------|------|------|------|-----|------|----|---------------|----|----|---------------|----|-----|------|---------|-------------|
| 70 | 18.7 | 8.7 | 11.7 | 4.5 | 9 | M5 | 5 | – | M5 | 5 | M4 | 35 | 17.5 | 20 ±0.1 | – |
| 80 | 22 | 10 | 16 | 5 | 10.4 | M5 | 9 | M6 | M5 | 7 | M4 | 46 | 23 | 32 ±0.2 | – |
| 120 | 34 | 12 | 24.5 | 7 | 11.2 | M5 | 9 | M6 | M6 | 7 | M5 | 68 | 34 | 55 ±0.2 | 20 |
| 185 | 46.5 | 15.5 | 35.2 | 8 | – | M8 | 9 | M6 | M8 | 9 | M5 | 108 | 54 | 90 ±0.2 | 40 |

| Size | H10* | L1 | L2 | L3 | L4 ±0.03 | L5 | L6 ±0.1 | L7 ±0.05 | L8 ±0.2 | L10* | T1 | T2 +0.1 | T3 | T4 | T5 |
|------|------|-------|----------|---------|-------------|---------|------------|-------------|------------|------|-----|------------|----|------|-----|
| 70 | 29.4 | 100 | 90 ±0.1 | 20 ±0.1 | 20 | 10 ±0.1 | 56 | – | – | 121 | 7.5 | 3.1 | 10 | 6 | – |
| 80 | 39 | 120 | 74 ±0.2 | 44 ±0.2 | 40 | 30 ±0.1 | 78 | 60 | – | 145 | 8.6 | 2.1 | 12 | 7 | 7.5 |
| 120 | 60.6 | 203.3 | 116 ±0.2 | 76 ±0.2 | 40 | 60 ±0.1 | 140 | 110 | – | 235 | 8.6 | 2.1 | 13 | 7.5 | 7.5 |
| 185 | – | 282.8 | 169 ±0.2 | 99 ±0.2 | 40 | 70 ±0.2 | 200 | 130 | 190 | – | 11 | 2.1 | 18 | 12.3 | 12 |

* Protected version

Passive guide axes EGC-FA, without drive

Technical data



Dimensions

Download CAD data → www.festo.com

GK-C – Standard slide with lubrication adapter

Size 80

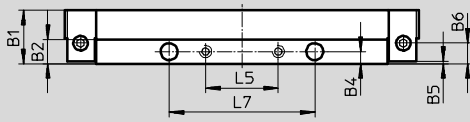

View A

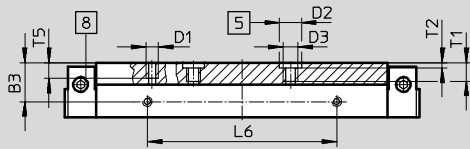
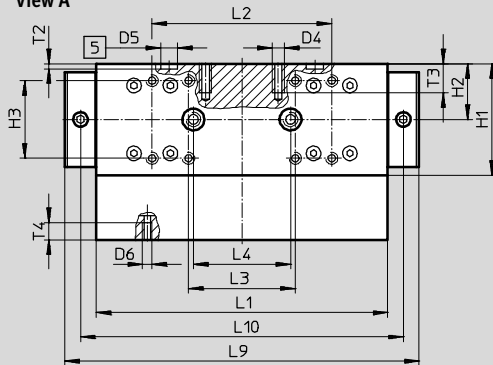

Size 120

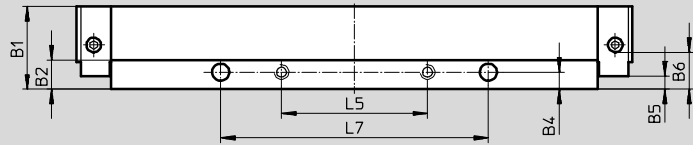

View A

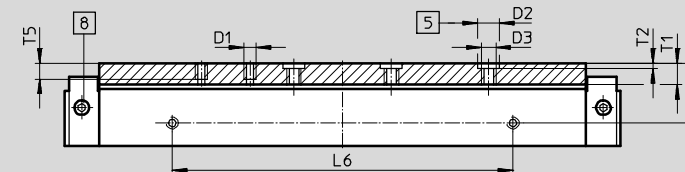
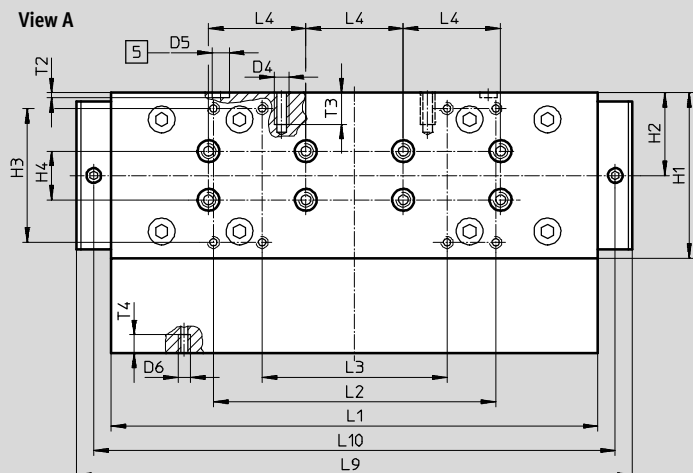

- 5 Hole for centring sleeve
- 8 Lubricating hole for lubrication adapter, M6 threaded connection, 6 mm deep

| Size | B1 | B2 | B3 | B4 | B5 | B6 | D1 | D2 ∅ | D3 | D4 |
|------|----|----|------|----|-----------|------|----|---------|----|----|
| 80 | 22 | 10 | 16 | 5 | 1 ±0.1 | 8.5 | M5 | 9 H7 | M6 | M5 |
| 120 | 34 | 12 | 24.5 | 7 | 5.5 | 18.2 | M5 | 9 | M6 | M6 |

| Size | D5 ∅ | D6 | H1 | H2 | H3 | H4 | L1 | L2 | L3 | L4 |
|------|---------|----|----|----|------------|------------|-------------|------------|------------|-------------|
| 80 | 7 H7 | M4 | 46 | 23 | 32 ±0.2 | – ±0.03 | 120 ±0.1 | 74 ±0.2 | 44 ±0.2 | 40 ±0.03 |
| 120 | 7 | M5 | 68 | 34 | 55 | 20 | 203.3 | 116 | 76 | 40 |

| Size | L5 | L6 | L7 | L9 | L10 | T1 | T2 | T3 | T4 | T5 |
|------|------------|------------|-------------|-------|-------|-----|-------------|----|-----|-----|
| 80 | 30 ±0.1 | 78 ±0.1 | 60 ±0.05 | 146 | 133 | 8.6 | 2.1 +0.1 | 12 | 7 | 7.5 |
| 120 | 60 | 140 | 110 | 226.9 | 214.3 | 8.6 | 2.1 | 13 | 7.5 | 7.5 |

Passive guide axes EGC-FA, without drive

Technical data

Dimensions

Download CAD data → www.festo.com

GK-C – Standard slide with lubrication adapter

Size 185

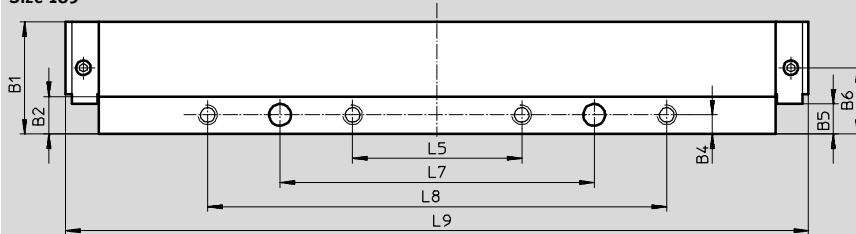

View A

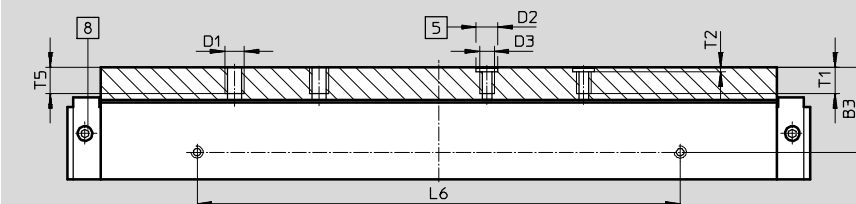
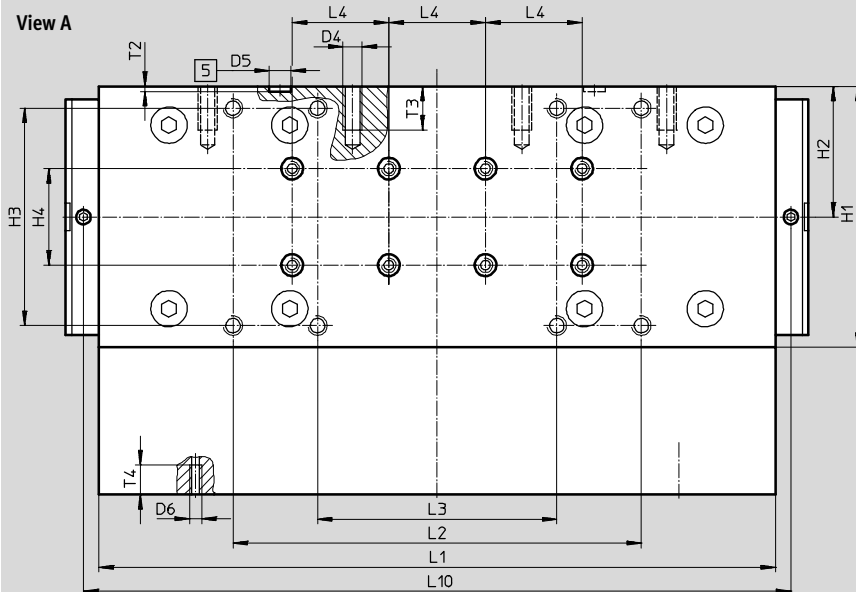

- 5 Hole for centring sleeve
- 8 Lubricating hole for lubrication adapter, M6 threaded connection, 6 mm deep

| Size | B1 | B2 | B3 | B4 | B5 | B6 | D1 | D2 ∅ | D3 | D4 |
|------|------|------|------|----|--------------|------|----|---------|----|----|
| 185 | 46.5 | 15.5 | 35.2 | 8 | ±0.1 12.5 | 27.5 | M8 | H7 9 | M6 | M8 |

| Size | D5 ∅ | D6 | H1 | H2 | H3 | H4 | L1 | L2 | L3 | L4 |
|------|---------|----|-----|----|------------|-------------|---------------|-------------|------------|-------------|
| 185 | H7 9 | M5 | 108 | 54 | ±0.2 90 | ±0.03 40 | ±0.1 282.8 | ±0.2 169 | ±0.2 99 | ±0.03 40 |

| Size | L5 | L6 | L7 | L8 | L9 | L10 | T1 | T2 | T3 | T4 | T5 |
|------|------------|-------------|--------------|-------------|-------|-------|----|-------------|----|------|----|
| 185 | ±0.2 70 | ±0.1 200 | ±0.05 130 | ±0.2 190 | 307.4 | 292.8 | 11 | +0.1 2.1 | 18 | 12.3 | 12 |

Passive guide axes EGC-FA, without drive

Technical data

FESTO

Dimensions

Download CAD data → www.festo.com

1HL/1HR/2H – With clamping unit

Size 80

1-channel, left

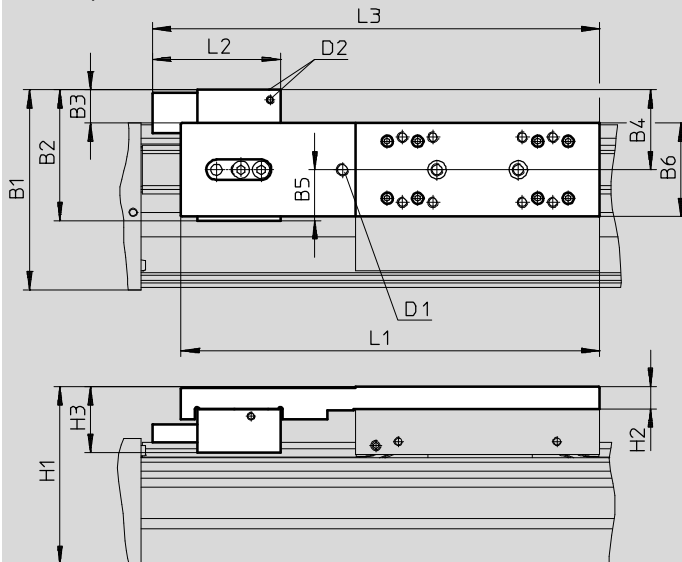

1-channel, right

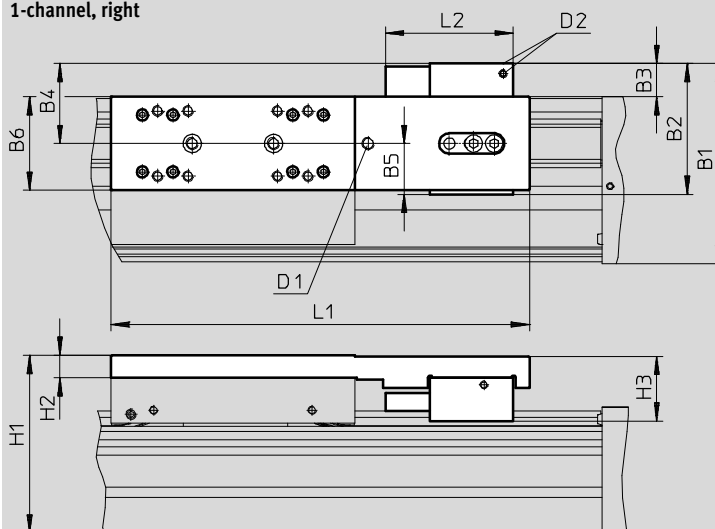

D2 Supply port

Passive guide axes EGC-FA, without drive

Technical data

Dimensions

Download CAD data → www.festo.com

1HL/1HR/2H – With clamping unit

Size 80

2-channel

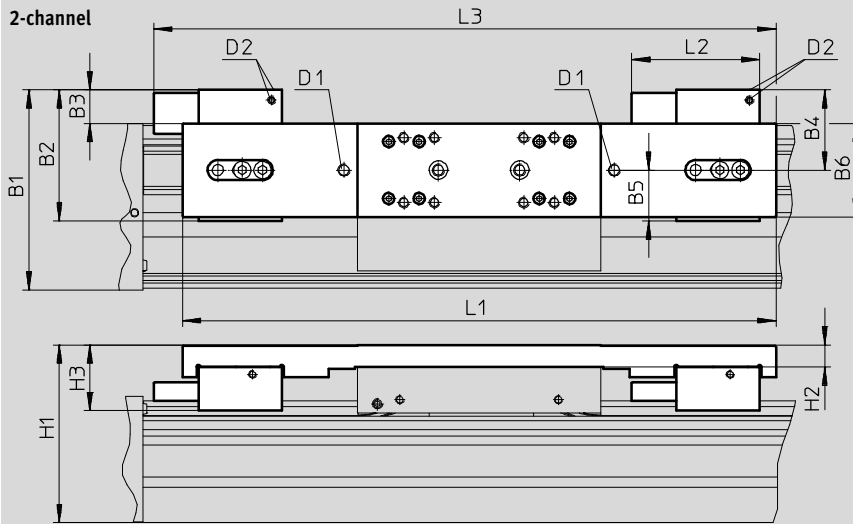

D2 Supply port

| Type | B1 | B2 | B3 | B4 | B5 | B6 | H1 | H2 | H3 | D1 | D2 | L1 | L2 | L3 |
|---------------------|------|------|------|------|----|----|------|----|------|----|----|-----|-----|-----|
| EGC-80-...-1HL-PN | 98.4 | 64.4 | 17.4 | 39.4 | 25 | 46 | 87.5 | 11 | 32.4 | M6 | M5 | 206 | 63 | 220 |
| EGC-80-...-1HR-PN | | | | | | | | | | | | | | - |
| EGC-80-...-C-1HL-PN | | | | | | | | | | | | | | 220 |
| EGC-80-...-C-1HR-PN | | | | | | | | | | | | - | | |
| EGC-80-...-2H-PN | | | | | | | | | | | | - | | |
| EGC-80-...-C-2H-PN | | | | | | | | | | | | 292 | 306 | |

Passive guide axes EGC-FA, without drive

Technical data

FESTO

Dimensions

Download CAD data → www.festo.com

1HL/1HR/2H – With clamping unit

Size 120/185

1-channel, left

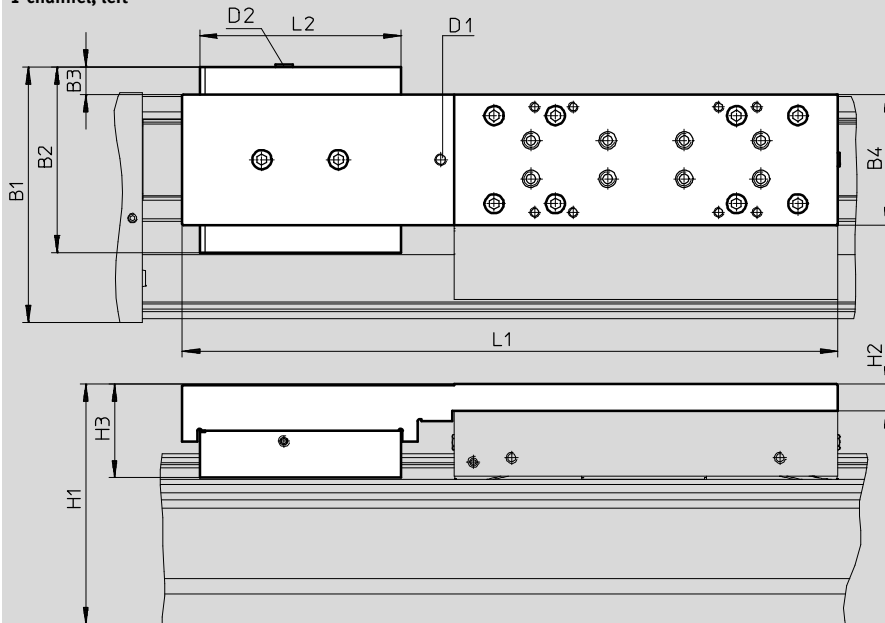

1-channel, right

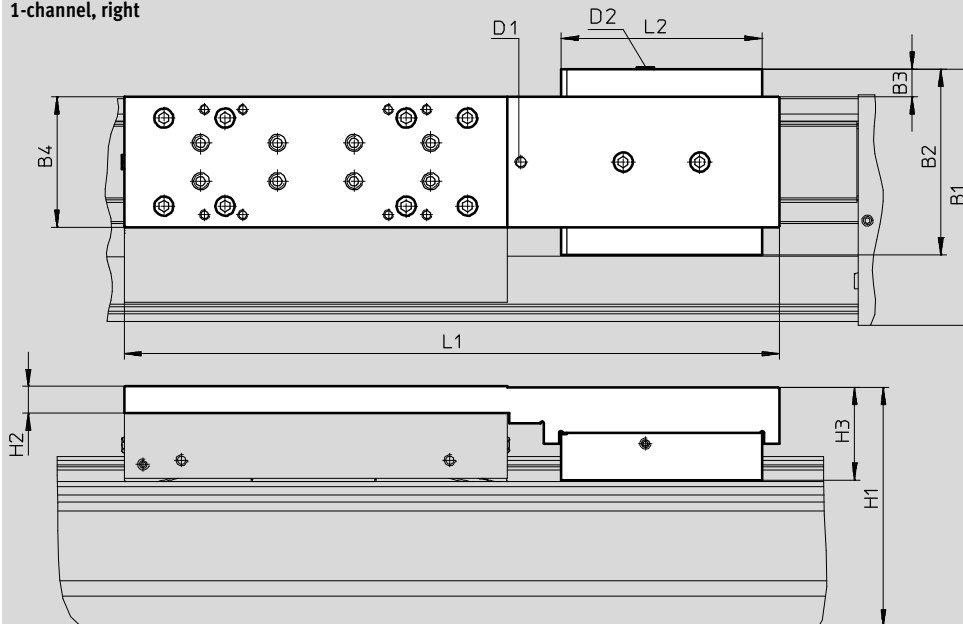

D2 Supply port

Passive guide axes EGC-FA, without drive

Technical data

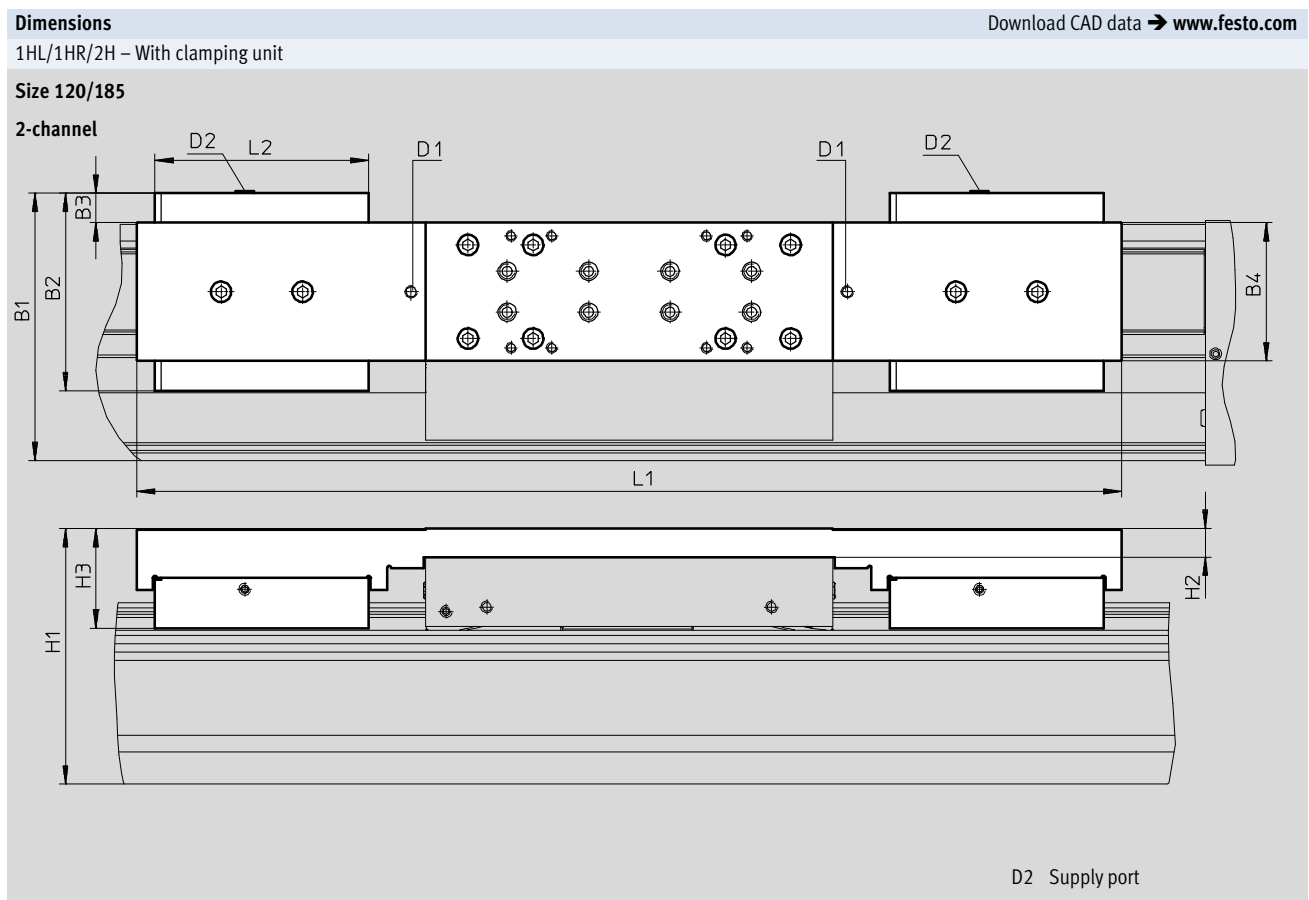

| Type | B1 | B2 | B3 | B4 | H1 | H2 | H3 | D1 | D2 | L1 | L2 |
|----------------------|-------|-----|------|-----|-------|----|------|----|----|-----|-----|
| Size 120 | | | | | | | | | | | |
| EGC-120-...-1HL-PN | 133.5 | 97 | 15.5 | 68 | 125.5 | 14 | 48.9 | M6 | M5 | 342 | 105 |
| EGC-120-...-1HR-PN | | | | | | | | | | | |
| EGC-120-...-C-1HL-PN | | | | | | | | | | | |
| EGC-120-...-C-1HR-PN | | | | | | | | | | | |
| EGC-120-...-2H-PN | | | | | | | | | | 484 | |
| EGC-120-...-C-2H-PN | | | | | | | | | | | |
| Size 185 | | | | | | | | | | | |
| EGC-185-...-1HL-PN | 196.5 | 131 | 12.5 | 108 | 189.5 | 17 | 64.1 | M6 | M5 | 432 | 109 |
| EGC-185-...-1HR-PN | | | | | | | | | | | |
| EGC-185-...-C-1HL-PN | | | | | | | | | | | |
| EGC-185-...-C-1HR-PN | | | | | | | | | | | |
| EGC-185-...-2H-PN | | | | | | | | | | 584 | |
| EGC-185-...-C-2H-PN | | | | | | | | | | | |

Passive guide axes EGC-FA, without drive

Ordering data – Modular products

Order code

Mandatory data

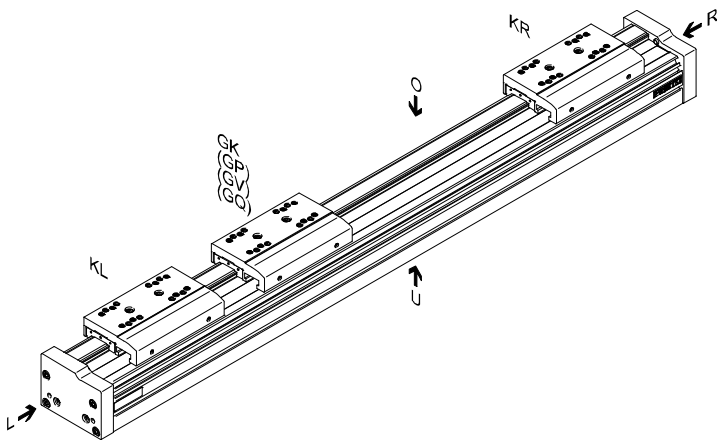
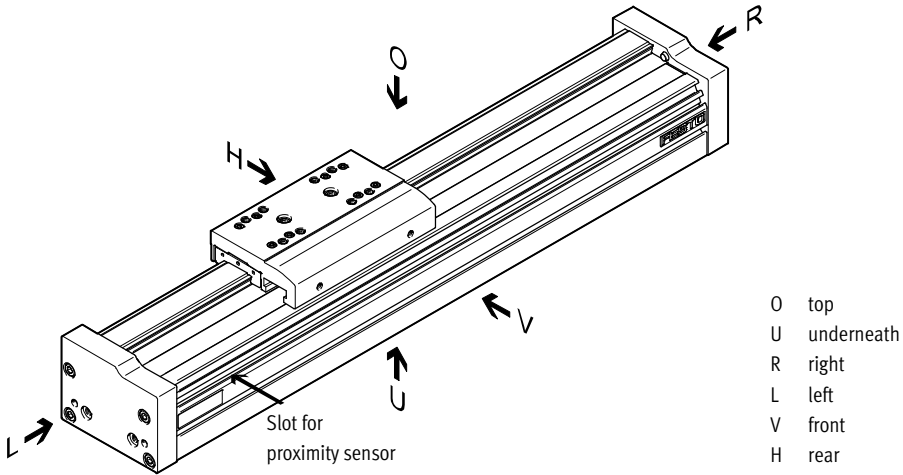

Passive guide axes EGC-FA, without drive

Ordering data – Modular products

Order code

Accessories

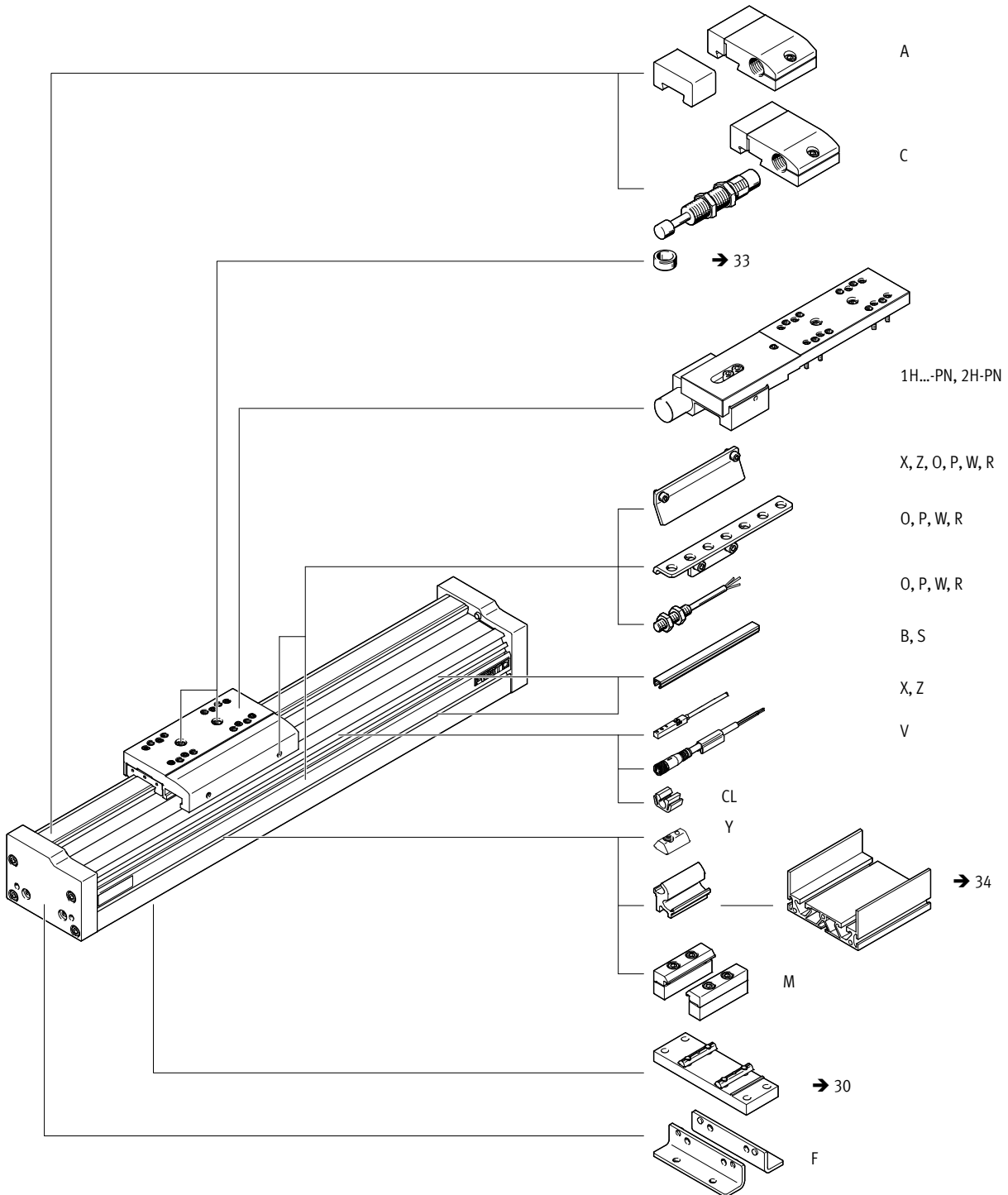

Passive guide axes EGC-FA, without drive

Ordering data – Modular products



| Ordering table | | | | | | | | |
|---------------------------|-----------------------------------|---------------------|---------------|---------------|-----------------|--------------|---------------|------|
| Size | 70 | 80 | 120 | 185 | Condi- tions | Code | Enter code | |
| M Module No. | 558864 | 558865 | 558866 | 558868 | | | | |
| Design | Passive guide axis | | | | | EGC | | EGC |
| Size | 70 | 80 | 120 | 185 | | -... | | -... |
| Stroke [mm] | 50 ... 5000 | 50 ... 8500 | 50 ... 8500 | 50 ... 8500 | [1] | -... | | -... |
| Guide | Passive guide axis | | | | | -FA | | -FA |
| Stroke reserve [mm] | 0 ... 999 (0 = no stroke reserve) | | | | [1] | -...H | | |
| Slide | Standard slide | | | | | -GK | | |
| | Standard slide, protected | | | | - | -GP | | |
| O Additional slide | 1 ... 2 | | | | [2] | -...K | | |
| Lubrication function | Standard | | | | | | | |
| | - | Lubrication adapter | | | | -C | | |
| Clamping unit | - | 1-channel, left | | [3] | -1HL | | | |
| | - | 1-channel, right | | [3] | -1HR | | | |
| | - | 2-channel | | [3] | -2H | | | |
| Actuation type | - | Pneumatic | | | -PN | | | |

- [1] -... The sum of the stroke length and 2x stroke reserve must not exceed the maximum stroke length
- [2] ... **K** If the protected slide variant (GP) is selected, then the additional slide is also protected
If the slide with lubrication adapter (GK-C) is selected, the additional slide (KL, KR) is also supplied with lubrication adapter
Working stroke reduction in combination with additional slide (K) → 11
- [3] **1HL, 1HR, 2H** Not with additional slide K
Only with PN
Working stroke reduction in combination with clamping unit (1HL, 1HR, 2H) → 12

- M** Mandatory data
- O** Options

Order code

EGC - - - **FA** - - - - - - - -

Passive guide axes EGC-FA, without drive

Ordering data – Modular products

| Ordering table | | | | 70 | 80 | 120 | 185 | Condi- tions | Code | Enter code |
|----------------|--------------------------------------------------------------------------------------------|------------------------------------------------------------------------------------------------------------------------------------------------------------------------------------|--------------------------------|----|----|-----|-----|-----------------|-------|---------------|
| Size | | | | | | | | | | |
| ↓ | Accessories | Accessories enclosed separately | | | | | | | ZUB- | ZUB- |
| ⓪ | Foot mounting | 1 | | | | | | | F | |
| | Profile mounting | 1 ... 50 | | | | | | | ...M | |
| | Cover | Mounting slot | 1 ... 50 (1 = 2 units, 500 mm) | | | | | ...B | | |
| | | Sensor slot | 1 ... 50 (1 = 2 units, 500 mm) | | | | | ...S | | |
| | Slot nut for mounting slot | 1 ... 99 | | | | | | | ...Y | |
| | Proximity sensor (SIES), inductive, slot type 8, PNP, incl. switch lug | N/O contact, 7.5 m cable | 1 ... 6 | | | | | ...X | | |
| | | N/C contact, 7.5 m cable | 1 ... 6 | | | | | ...Z | | |
| | Emergency buffer with retainer | 1 ... 2 | | | | | | 4 | ...A | |
| | Shock absorber with retainer | 1 ... 2 | | | | | | 5 | ...C | |
| | Proximity sensor (SIEN), inductive, M8, PNP, incl. switch lug with sensor bracket | N/O contact, 2.5 m cable | 1 ... 99 | | | | | ...O | | |
| | | N/C contact, 2.5 m cable | 1 ... 99 | | | | | ...P | | |
| | Plug socket with cable 2.5 m, M8, 3-wire | N/O contact, plug M8 | 1 ... 99 | | | | | ...W | | |
| | | N/C contact, plug M8 | 1 ... 99 | | | | | ...R | | |
| | Cable clip | 10, 20, 30, 40, 50, 60, 70, 80, 90 | | | | | | | ...CL | |
| | Operating instructions | Express waiver - no operating instructions to be included (already available) (operating instructions in pdf format are available free of charge on the Internet at www.festo.com) | | | | | | | -DN | |

- 4 ...A Emergency buffer with retainer A cannot be combined with slide GP, GK-C, shock absorber with retainer C and clamping unit 1H...-PN, 2H-PN
- 5 ...C Shock absorber with retainer C cannot be combined with slide GP, GK-C, emergency buffer with retainer A and clamping unit 1H...-PN, 2H-PN

 Note

The code X, Z includes a switch lug in the scope of delivery.

The code O, P, W, R includes one switch lug and max. two sensor brackets in the scope of delivery.

- M Mandatory data
- ⓪ Options

Transfer order code

ZUB - -

Passive guide axes EGC-FA, without drive

Accessories



Foot mounting HPE
(order code F)

Material:
Galvanised steel
RoHS-compliant

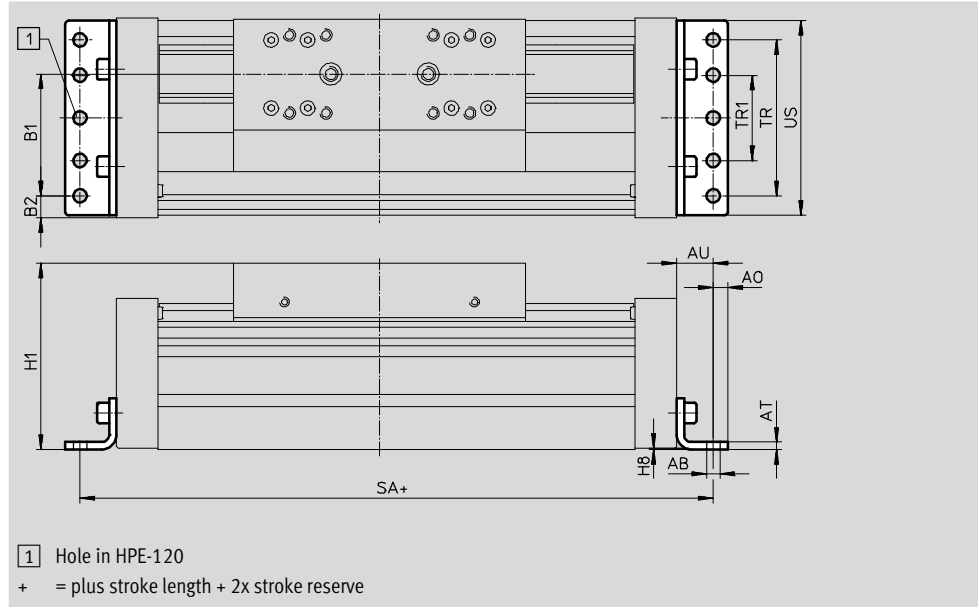

| Dimensions and ordering data | | | | | | | | |
|------------------------------|---------|----|----|----|-----|------|-------|-----|
| For size | AB Ø | A0 | AT | AU | B1 | B2 | H1 | H8 |
| 70 | 5.5 | 6 | 3 | 13 | 37 | 14.5 | 64 | 0.5 |
| 80 | 5.5 | 6 | 3 | 15 | 38 | 21 | 76.5 | 0.5 |
| 120 | 9 | 8 | 6 | 22 | 65 | 20 | 111.5 | 0.6 |
| 185 | 9 | 12 | 8 | 25 | 118 | 13 | 172.5 | 0.5 |

| For size | SA | TR | TR1 | US | Weight [g] | Part No. | Type |
|----------|-----|-----|-----|-----|---------------|----------|---------|
| 70 | 189 | 40 | - | 67 | 115 | 558321 | HPE-70 |
| 80 | 220 | 40 | - | 80 | 150 | 558322 | HPE-80 |
| 120 | 350 | 80 | - | 116 | 578 | 558323 | HPE-120 |
| 185 | 456 | 160 | 80 | 182 | 1438 | 558325 | HPE-185 |

Passive guide axes EGC-FA, without drive

Accessories

Profile mounting MUE
(order code M)

Material:
Anodised aluminium
RoHS-compliant

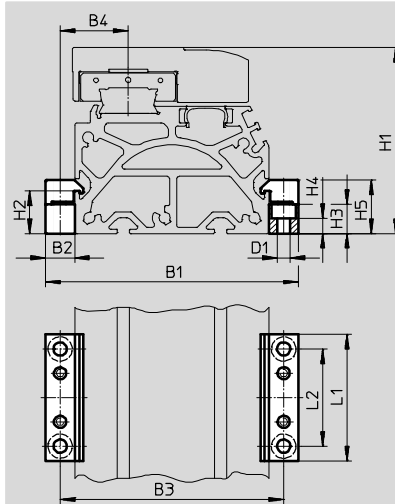

| Dimensions and ordering data | | | | | | | | |
|------------------------------|-----|----|-----|------|---------|-------|------|----|
| For size | B1 | B2 | B3 | B4 | D1 ∅ | H1 | H2 | H3 |
| 70 | 91 | 12 | 79 | 22.5 | 5.5 | 64 | 17.5 | 12 |
| 80 | 104 | 12 | 92 | 28 | 5.5 | 76.5 | 17.5 | 12 |
| 120 | 154 | 19 | 135 | 42.5 | 9 | 111.5 | 16 | 14 |
| 185 | 220 | 19 | 201 | 62.5 | 9 | 172.5 | 16 | 14 |

| For size | H4 | H5 | L1 | L2 | Weight [g] | Part No. | Type |
|----------|-----|------|----|----|---------------|----------|-------------|
| 70 | 6.2 | 22 | 52 | 40 | 80 | 558043 | MUE-70/80 |
| 80 | 6.2 | 22 | 52 | 40 | 80 | 558043 | MUE-70/80 |
| 120 | 5.5 | 29.5 | 90 | 40 | 290 | 558044 | MUE-120/185 |
| 185 | 5.5 | 29.5 | 90 | 40 | 290 | 558044 | MUE-120/185 |

Passive guide axes EGC-FA, without drive

Accessories



Central support EAHF

Materials:

Anodised aluminium

RoHS-compliant

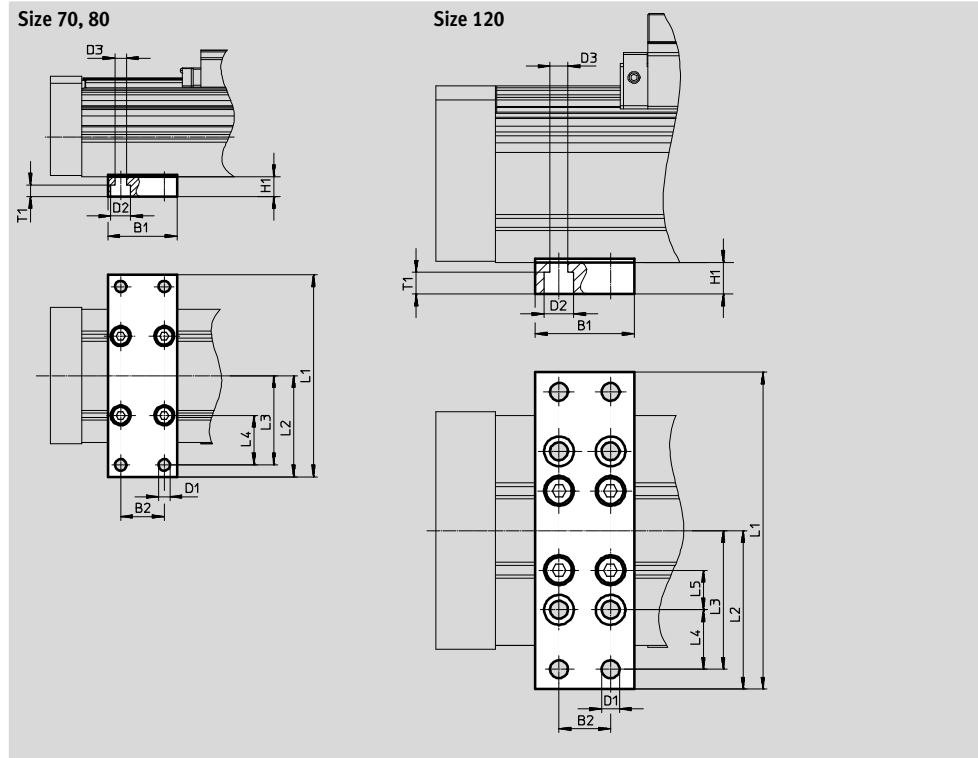
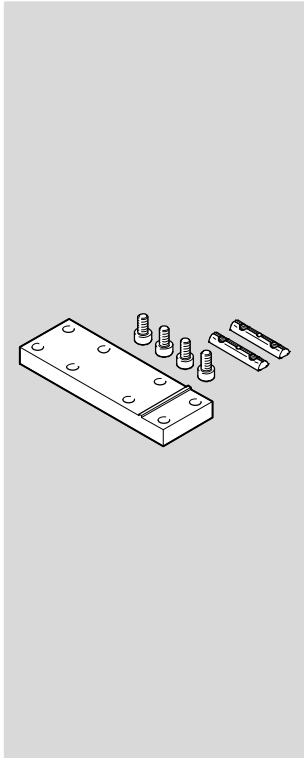

| Dimensions and ordering data | | | | | | | |
|------------------------------|----|----|---------|---------|---------|----|-----|
| For size | B1 | B2 | D1 Ø | D2 Ø | D3 Ø | H1 | L1 |
| 70 | 35 | 22 | 5.8 | 10 | 5.8 | 10 | 102 |
| 80 | | | | | | | 112 |
| 120 | 50 | 26 | 9 | 15 | 9 | 16 | 160 |

| For size | L2 | L3 | L4 | L5 | T1 | Weight [g] | Part No. | Type |
|----------|----|----|----|----|-----|---------------|----------|---------------|
| 70 | 51 | 45 | 25 | - | 5.7 | 113 | 2349256 | EAHF-L5-70-P |
| 80 | 56 | 50 | 30 | | | 123 | 3535188 | EAHF-L5-80-P |
| 120 | 80 | 70 | 30 | 20 | 11 | 384 | 2410274 | EAHF-L5-120-P |

Passive guide axes EGC-FA, without drive

Accessories

Shock absorber retainer KYE

Emergency buffer NPE → 33

Shock absorber YSRW → 33

(order code A or C)

Material:

Anodised aluminium

RoHS-compliant

Cannot be used in combination with

the variant GP or GK-C and 1H...-PN,

2H-PN.

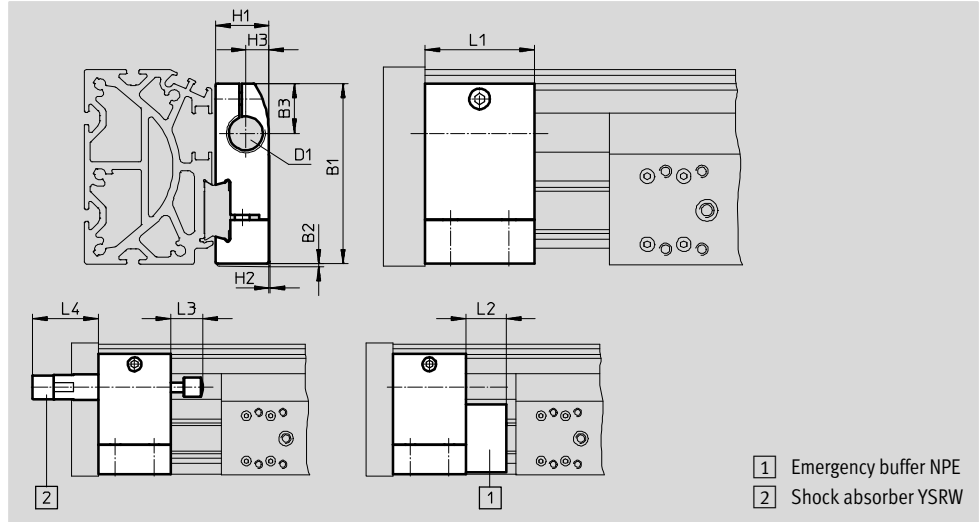

- 1 Emergency buffer NPE
- 2 Shock absorber YSRW

| Dimensions and ordering data | | | | | | | | | | | | | | |
|------------------------------|-------|----|------|---------|------|-----|-----|----|----|----|------|------------|----------|---------|
| For size | B1 | B2 | B3 | D1 | H1 | H2 | H3 | L1 | L2 | L3 | L4 | Weight [g] | Part No. | Type |
| 70 | 57.5 | 1 | 16.5 | M12X1 | 18.2 | 0.5 | 7.5 | 30 | 15 | 14 | 32 | 75 | 557584 | KYE-70 |
| 80 | 74.2 | 1 | 20.5 | M16X1 | 22 | 0.5 | 9.5 | 45 | 25 | 20 | 41 | 170 | 557585 | KYE-80 |
| 120 | 108.5 | 1 | 26 | M22X1.5 | 31 | 1 | 14 | 60 | 40 | 26 | 48.5 | 680 | 557586 | KYE-120 |
| 185 | 168 | 1 | 37 | M26X1.5 | 42 | 4 | 18 | 75 | 60 | 34 | 58.5 | 1075 | 557587 | KYE-185 |

Switch lug SF-EGC-1

for sensing via proximity sensor

SIES-8M

(order code X or Z)

Material:

Galvanised steel

RoHS-compliant

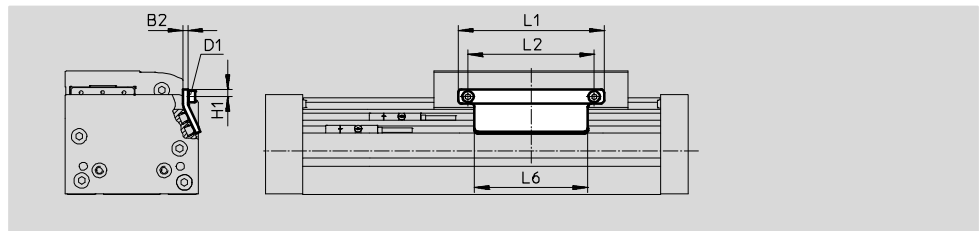

| Dimensions and ordering data | | | | | | | | | |
|------------------------------|----|----|------|-----|-----|-----|------------|----------|--------------|
| For size | B2 | D1 | H1 | L1 | L2 | L6 | Weight [g] | Part No. | Type |
| 70 | 3 | M4 | 4.65 | 70 | 56 | 50 | 50 | 558047 | SF-EGC-1-70 |
| 80 | 3 | M4 | 4.65 | 90 | 78 | 70 | 63 | 558048 | SF-EGC-1-80 |
| 120 | 3 | M5 | 8 | 170 | 140 | 170 | 147 | 558049 | SF-EGC-1-120 |
| 185 | 3 | M5 | 10 | 230 | 200 | 230 | 246 | 558051 | SF-EGC-1-185 |

Passive guide axes EGC-FA, without drive

Accessories



Switch lug SF-EGC-2

for sensing via proximity sensor
SIEN-M8B (order code O, P, W or R) or
SIES-8M (order code X or Z)

Material:
Galvanised steel
RoHS-compliant

Sensor bracket HWS-EGC
for proximity sensor SIEN-M8B
(order code O, P, W or R)

Material:
Galvanised steel
RoHS-compliant

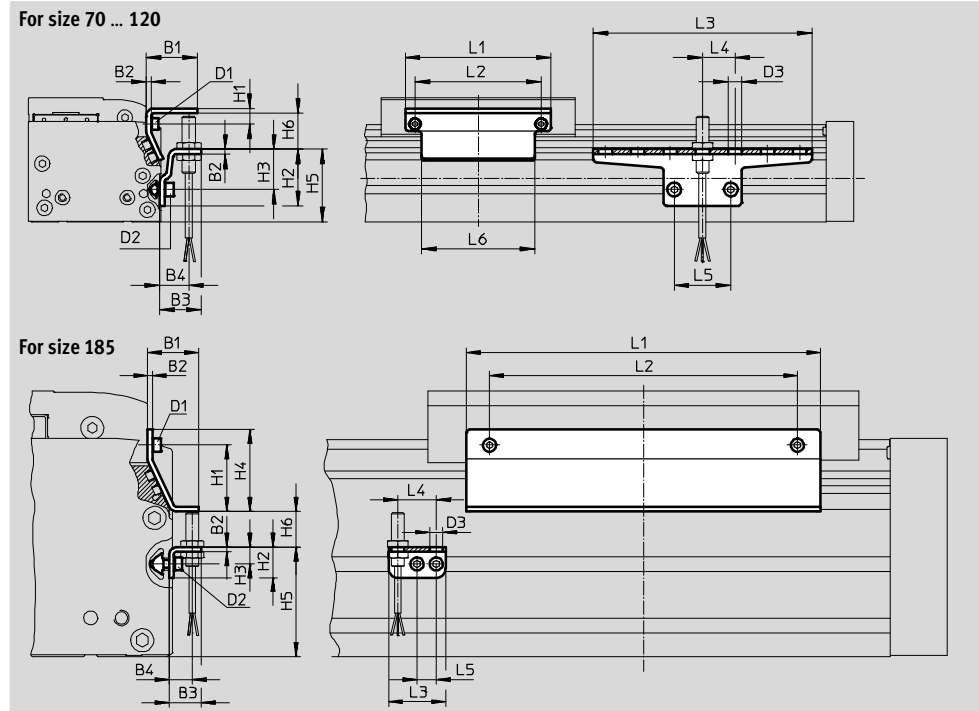
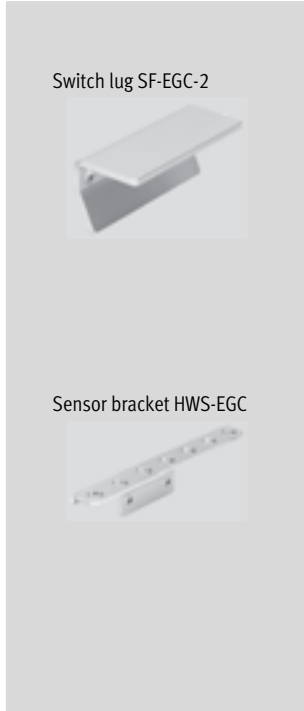

| Dimensions and ordering data | | | | | | | | | |
|------------------------------|------|----|------|----|----|----|-----|------|----|
| For size | B1 | B2 | B3 | B4 | D1 | D2 | D3 | H1 | H2 |
| 70 | 31.5 | 3 | 25.5 | 18 | M4 | M5 | 8.4 | 9.5 | 35 |
| 80 | 31.5 | 3 | 25.5 | 18 | M4 | M5 | 8.4 | 9.5 | 35 |
| 120 | 32 | 3 | 25.5 | 18 | M5 | M5 | 8.4 | 13.2 | 65 |
| 185 | 33 | 3 | 25.5 | 15 | M5 | M5 | 8.4 | 43 | 20 |





| For size | H3 | H4 | H5 | H6 max. | L1 | L2 | L3 | L4 | L5 | L6 |
|----------|----|----|----|---------|-----|-----|-----|----|------|-----|
| 70 | 25 | - | 45 | 13.5 | 70 | 56 | 135 | 20 | 35 | 50 |
| 80 | 25 | - | 45 | 23.5 | 90 | 78 | 135 | 20 | 35 | 70 |
| 120 | 55 | - | 75 | 24 | 170 | 140 | 215 | 20 | 35 | 170 |
| 185 | 11 | 53 | 71 | 25.5 | 230 | 200 | 37 | 25 | 12.5 | 230 |

| For size | Weight [g] | Part No. | Type |
|------------|------------|----------|--------------|
| Switch lug | | | |
| 70 | 100 | 558052 | SF-EGC-2-70 |
| 80 | 130 | 558053 | SF-EGC-2-80 |
| 120 | 277 | 558054 | SF-EGC-2-120 |
| 185 | 390 | 558056 | SF-EGC-2-185 |

| For size | Weight [g] | Part No. | Type |
|----------------|------------|----------|-----------------|
| Sensor bracket | | | |
| 70 | 110 | 558057 | HWS-EGC-M5 |
| 80 | 110 | 558057 | HWS-EGC-M5 |
| 120 | 217 | 570365 | HWS-EGC-M8-B |
| 185 | 58 | 560517 | HWS-EGC-M8-KURZ |

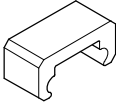
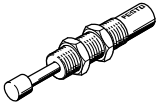
Passive guide axes EGC-FA, without drive

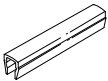
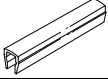
Accessories

| Ordering data | | | | | | |
|-------------------------------------------------------------------------------------|--------------|------------------------------------------------------------|---------------------------------|----------------|--------------------|------------------|
| | For size | Remarks | Order code | Part No. | Type | PU ¹⁾ |
| Emergency buffer NPE | | | | | | |
|  | 70 | For use in combination with shock absorber retainer KYE | A | 562581 | NPE-70 | 1 |
| | 80 | | | 562582 | NPE-80 | |
| | 120 | | | 562583 | NPE-120 | |
| | 185 | | | 562584 | NPE-185 | |
| Shock absorber YSRW | | | Technical data → Internet: ysrw | | | |
|  | 70 | For use in combination with shock absorber retainer KYE | C | 191194 | YSRW-8-14 | 1 |
| | 80 | | | 191196 | YSRW-12-20 | |
| | 120 | | | 191197 | YSRW-16-26 | |
| | 185 | | | 191198 | YSRW-20-34 | |
| Slot nut NST | | | | | | |
|  | 70, 80 | For mounting slot | Y | 150914 | NST-5-M5 | 1 |
| | | | | 8047843 | NST-5-M5-10 | 10 |
| | | | | 8047878 | NST-5-M5-50 | 50 |
| | 120, 185 | For mounting slot | Y | 150915 | NST-8-M6 | 1 |
| | | | | 8047868 | NST-8-M6-10 | 10 |
| | | | | 8047869 | NST-8-M6-50 | 50 |
| Centring pin/sleeve ZBS/ZBH²⁾ | | | | | | |
|  | 70 | For slide | - | 150928 | ZBS-5 | 10 |
| | 80, 120, 185 | | | 150927 | ZBH-9 | |
| Slot cover ABP | | | | | | |
|  | 70, 80 | For mounting slot every 0.5 m | B | 151681 | ABP-5 | 2 |
| | 120, 185 | | | 151682 | ABP-8 | |
| Slot cover ABP-S | | | | | | |
|  | 70 ... 185 | For sensor slot every 0.5 m | S | 563360 | ABP-5-S1 | 2 |
| Clip SMBK | | | | | | |
|  | 70 ... 185 | For sensor slot, for attaching the proximity sensor cables | CL | 534254 | SMBK-8 | 10 |

1) Packaging unit

2) 2 centring pins/sleeves included in the scope of delivery of the axis

Passive guide axes EGC-FA, without drive

Accessories





Mounting options between axis and support profile

Depending on the adapter kit, the spacing between the axis and the support profile is:
x = 20 mm or 50 mm

The support profile must be mounted using at least 2 adapter kits. For longer strokes, an adapter kit must be used every 500 mm.

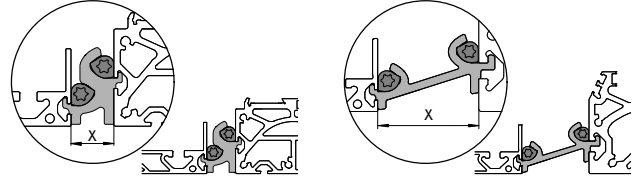
Example:



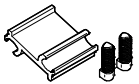
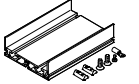

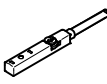
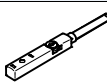

| Ordering data | | | | | |
|-------------------------------------------------------------------------------------|------------|---------------------------------------------------------------------------------------------------------------------------------------------------|----------|------------------|------------------|
| | For size | Comment | Part No. | Type | PU ¹⁾ |
| Adapter kit DHAM | | | | | |
|  | 80 | <ul style="list-style-type: none"> For mounting the support profile on the axis Spacing between axis and profile is 20 mm | 562241 | DHAM-ME-N1-CL | 1 |
| | 120 | | 562242 | DHAM-ME-N2-CL | |
|  | 70, 80 | <ul style="list-style-type: none"> For mounting the support profile on the axis Spacing between axis and profile is 50 mm | 574560 | DHAM-ME-N1-50-CL | |
| | 120 | | 574561 | DHAM-ME-N2-50-CL | |
| Support profile HMIA | | | | | |
|  | 70 ... 120 | <ul style="list-style-type: none"> For guiding an energy chain | 539379 | HMIA-E07- | 1 |



1) Packaging unit

| Ordering data – Proximity sensors for T-slot, inductive | | | | | | | Technical data → Internet: sies | |
|-------------------------------------------------------------------------------------|--------------------------------------------------------------------|-----------------------|------------------|------------------|------------|----------|---------------------------------|--|
| | Type of mounting | Electrical connection | Switching output | Cable length [m] | Order code | Part No. | Type | |
| N/O contact | | | | | | | | |
|  | Insertable in the slot from above, flush with the cylinder profile | Cable, 3-wire | PNP | 7.5 | X | 551386 | SIES-8M-PS-24V-K-7,5-OE | |
| | | Plug M8x1, 3-pin | | 0.3 | - | 551387 | SIES-8M-PS-24V-K-0,3-M8D | |
| | | Cable, 3-wire | NPN | 7.5 | - | 551396 | SIES-8M-NS-24V-K-7,5-OE | |
| | | Plug M8x1, 3-pin | | 0.3 | - | 551397 | SIES-8M-NS-24V-K-0,3-M8D | |
| N/C contact | | | | | | | | |
|  | Insertable in the slot from above, flush with the cylinder profile | Cable, 3-wire | PNP | 7.5 | Z | 551391 | SIES-8M-PO-24V-K-7,5-OE | |
| | | Plug M8x1, 3-pin | | 0.3 | - | 551392 | SIES-8M-PO-24V-K-0,3-M8D | |
| | | Cable, 3-wire | NPN | 7.5 | - | 551401 | SIES-8M-NO-24V-K-7,5-OE | |
| | | Plug M8x1, 3-pin | | 0.3 | - | 551402 | SIES-8M-NO-24V-K-0,3-M8D | |

Passive guide axes EGC-FA, without drive

Accessories

| Ordering data – Proximity sensors M8 (round design), inductive | | | | | | Technical data → Internet: sien | |
|-----------------------------------------------------------------------------------|-----------------------|-----|------------------|------------------|------------|---------------------------------|-----------------|
| | Electrical connection | LED | Switching output | Cable length [m] | Order code | Part No. | Type |
| N/O contact | | | | | | | |
|  | Cable, 3-wire | ■ | PNP | 2.5 | O | 150386 | SIEN-M8B-PS-K-L |
|  | Plug M8x1, 3-pin | ■ | PNP | – | W | 150387 | SIEN-M8B-PS-S-L |
| N/C contact | | | | | | | |
|  | Cable, 3-wire | ■ | PNP | 2.5 | P | 150390 | SIEN-M8B-PO-K-L |
|  | Plug M8x1, 3-pin | ■ | PNP | – | R | 150391 | SIEN-M8B-PO-S-L |

| Ordering data – Connecting cables | | | | Technical data → Internet: nebu | |
|-------------------------------------------------------------------------------------|------------------------------|------------------------------|------------------|---------------------------------|---------------------|
| | Electrical connection, left | Electrical connection, right | Cable length [m] | Part No. | Type |
|  | Straight socket, M8x1, 3-pin | Cable, open end, 3-wire | 2.5 | 159420 | SIM-M8-3GD-2,5-PU |
| | | | 2.5 | 541333 | NEBU-M8G3-K-2.5-LE3 |
| | | | 5 | 541334 | NEBU-M8G3-K-5-LE3 |
|  | Angled socket, M8x1, 3-pin | Cable, open end, 3-wire | 2.5 | 541338 | NEBU-M8W3-K-2.5-LE3 |
| | | | 5 | 541341 | NEBU-M8W3-K-5-LE3 |

Product Range and Company Overview

A Complete Suite and Company Overview

Our experienced engineers provide complete support at every stage of your development process, including: conceptualization, analysis, engineering, design, assembly, documentation, validation, and production.



Custom Automation Components
Complete custom engineered solutions



Custom Control Cabinets
Comprehensive engineering support and on-site services



Complete Systems
Shipment, stocking and storage services

The Broadest Range of Automation Components

With a comprehensive line of more than 30,000 automation components, Festo is capable of solving the most complex automation requirements.



Electromechanical
Electromechanical actuators, motors, controllers & drivers



Pneumatics
Pneumatic linear and rotary actuators, valves, and air supply



PLCs and I/O Devices
PLC's, operator interfaces, sensors and I/O devices

Supporting Advanced Automation... As No One Else Can!

Festo is a leading global manufacturer of pneumatic and electromechanical systems, components and controls for industrial automation, with more than 16,000 employees in 60 national headquarters serving more than 180 countries. For more than 80 years, Festo has continuously elevated the state of manufacturing with innovations and optimized motion control solutions that deliver higher performing, more profitable automated manufacturing and processing equipment. Our dedication to the advancement of automation extends beyond technology to the education and development of current and future automation and robotics designers with simulation tools, teaching programs, and on-site services.

Quality Assurance, ISO 9001 and ISO 14001 Certifications

Festo Corporation is committed to supply all Festo products and services that will meet or exceed our customers' requirements in product quality, delivery, customer service and satisfaction.

To meet this commitment, we strive to ensure a consistent, integrated, and systematic approach to management that will meet or exceed the requirements of the ISO 9001 standard for Quality Management and the ISO 14001 standard for Environmental Management.



© Copyright 2013, Festo Corporation. While every effort is made to ensure that all dimensions and specifications are correct, Festo cannot guarantee that publications are completely free of any error, in particular typing or printing errors. Accordingly, Festo cannot be held responsible for the same. For Liability and Warranty conditions, refer to our "Terms and Conditions of Sale", available from your local Festo office. All rights reserved. No part of this publication may be reproduced, distributed, or transmitted in any form or by any means, electronic, mechanical, photocopying or otherwise, without the prior written permission of Festo. All technical data subject to change according to technical update.



Printed on recycled paper at New Horizon Graphic, Inc., FSC certified as an environmental friendly printing plant.

Festo North America

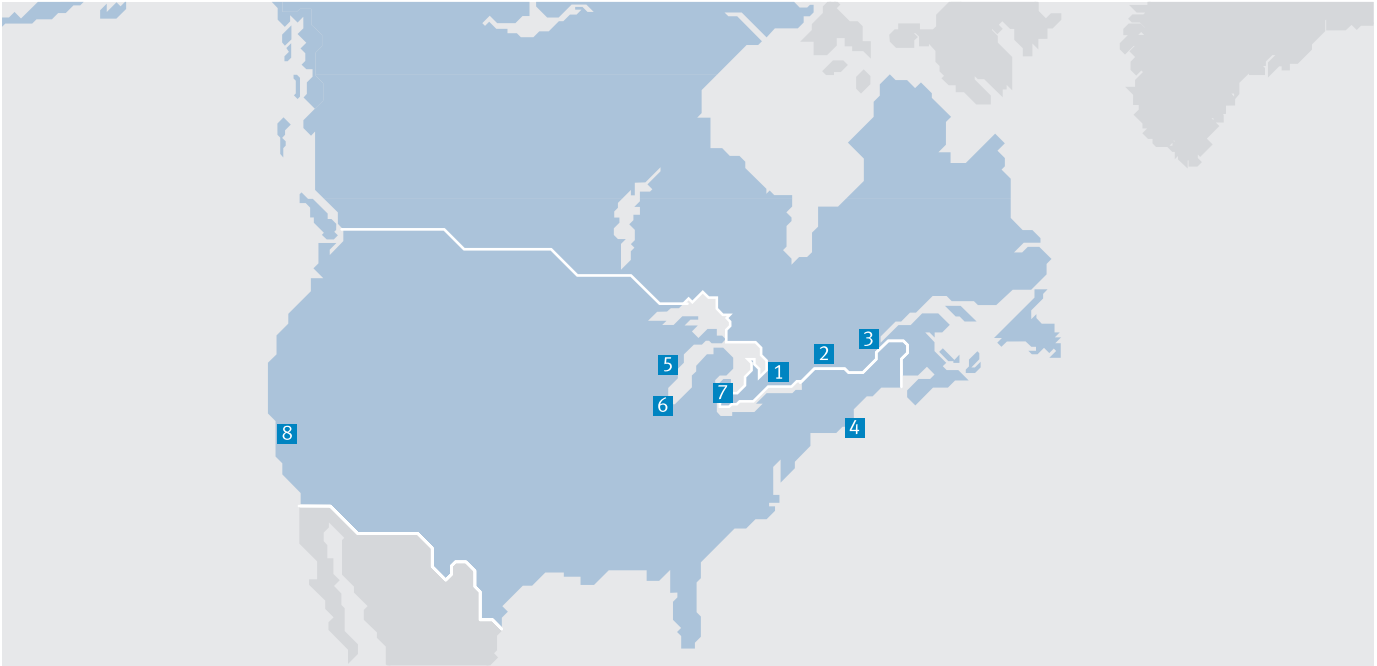

**1 Festo Canada
Headquarters
Festo Inc.**
5300 Explorer Drive
Mississauga, ON
L4W 5G4

2 Montréal
5600, Trans-Canada
Pointe-Claire, QC
H9R 1B6

3 Québec City
2930, rue Watt#117
Québec, QC
G1X 4G3



**4 Festo United States
Headquarters
Festo Corporation**
395 Moreland Road
Hauppauge, NY
11788

5 Appleton
North 922 Tower View Drive, Suite N
Greenville, WI
54942

7 Detroit
1441 West Long Lake Road
Troy, MI
48098

6 Chicago
85 W Algonquin - Suite 340
Arlington Heights, IL
60005

8 Silicon Valley
4935 Southfront Road, Suite F
Livermore, CA
94550

Festo Regional Contact Center

Canadian Customers

Commercial Support:
Tel: 1 877 GO FESTO (1 877 463 3786)
Fax: 1 877 FX FESTO (1 877 393 3786)
Email: festo.canada@ca.festo.com

Technical Support:

Tel: 1 866 GO FESTO (1 866 463 3786)
Fax: 1 877 FX FESTO (1 877 393 3786)
Email: technical.support@ca.festo.com

USA Customers

Commercial Support:
Tel: 1 800 99 FESTO (1 800 993 3786)
Fax: 1 800 96 FESTO (1 800 963 3786)
Email: customer.service@us.festo.com

Technical Support:

Tel: 1 866 GO FESTO (1 866 463 3786)
Fax: 1 800 96 FESTO (1 800 963 3786)
Email: product.support@us.festo.com