

Bellows actuator EB



Bellows actuator EB

Key features

Key features

- Suitable for use in harsh, dusty ambient conditions
- Can be used under water
- Sturdy design
- Large forces range from 1 ... 50 KN
- Low installation height
- No stick-slip effect
- Maintenance-free

Bellows actuators function both as driving and pneumatic spring components. Bellows actuators function as a driving component by providing supply and exhaust functions. As the stroke increases, the force generated is reduced in relation to the

contractional force of the bellows. When bellows actuators are supplied with permanent pressure, they act as a cushioning component. The simple design consists of two metal port plates with an attached rubber

bellows. There are no sealing components and no moving mechanical parts. Bellows actuators are single-acting drives that do not require spring returns, as the reset is achieved by the application of external force.

EB-80

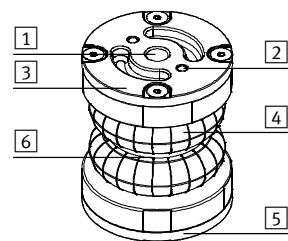

EB-145 ... 385

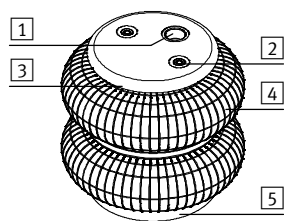

- 1 Pneumatic connection
- 2 Mounting thread
- 3 Port plate, on top
- 4 Bellows
- 5 Port plate, underneath
- 6 Belt ring

Prerequisites for using a bellows actuator

Space required

Observe the installation space to ensure the bellows actuator does not come into contact with other machine parts during expansion.

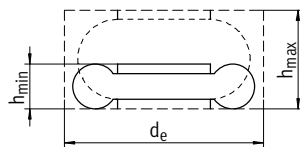

Combined installation

When using two or more bellows actuators, the necessary mounting plates must be inserted between the cylinders to prevent a lateral break out.

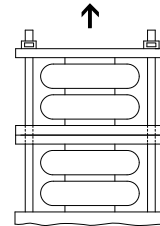

Lateral offset

The max. lateral offset must not be exceeded.

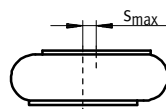

Tilted installation

The max. tilt angle α must not be exceeded to ensure that the bellows walls cannot touch.

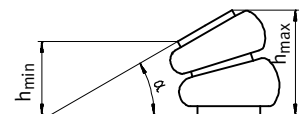

Minimum height

The bellows actuator must not fall below a min. height, otherwise it will be damaged.

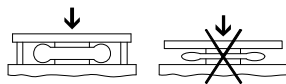

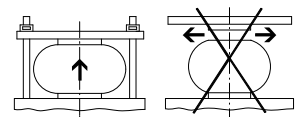

Maximum height

The bellows actuator must not exceed a max. height, otherwise it will be damaged.

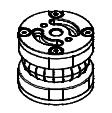

Bellows actuator EB

Product range overview and type codes

Product range overview						
Function	Feature	Type	Size	Stroke [mm]	Thrust ¹⁾ [kN]	Recommended operating height [mm]
Single-acting		Single-bellows actuator	80	20	1.7	60
			145	60	3.2	90
			165	65	5.7	90
			215	80	8.3	110
			250	85	11.9	110
			325	95	21.8	130
		Double-bellows actuator	80	45	1.4	90
			145	100	2.4	160
			165	125	3.8	175
			215	155	8.0	190
			250	185	10.7	210
			325	215	20.6	240
			385	230	31.5	250

1) At recommended operating height and operating pressure of 6 bar

Type codes

	EB	–	250	–	85
Type					
Single-acting					
EB	Bellows				
Size					
Stroke [mm]					

Bellows actuator EB

Technical data

Function



-  - Diameter
80 ... 385 mm

-  - Stroke length
20 ... 230 mm



General technical data								
Size		80	145	165	215	250	325	385
Pneumatic port		G1/4	G1/8	G1/4	G3/4	G3/4	G1/4	G1/4
Stroke								
Single-bellows actuator	[mm]	20	60	65	80	85	95	115
Double-bellows actuator	[mm]	45	100	125	155	185	215	230
Mode of operation		Single-acting						
Type of mounting		Via internal thread						
Mounting position		Any						

Operating and environmental conditions								
Size		80	145	165	215	250	325	385
Operating medium		Compressed air to ISO 8573-1:2010 [-:-:4]						
Note on the operating/control medium ¹⁾		Lubricated operation not possible						
Operating pressure	[bar]	0 ... 8						
Ambient temperature	[°C]	-40 ... +70						
Corrosion resistance class CRC ²⁾		0	2					

1) Additional operating media on request

2) Corrosion resistance class CRC 0 to Festo standard FN 940070

No corrosion stress. Applies to small, optically irrelevant standard parts such as threaded pins, circlips and clamping sleeves which are usually only available in a phosphated or burnished version (and possibly oiled) as well as to ball bearings (for components < CRC 3) and plain bearings.

Corrosion resistance class CRC 2 to Festo standard FN 940070

Moderate corrosion stress. Indoor applications in which condensation may occur. External visible parts with primarily decorative requirements for the surface and which are in direct contact with the ambient atmosphere typical for industrial applications.

Weight [g]								
Size		80	145	165	215	250	325	385
Single-bellows actuator		500	900	1200	2000	2300	4100	5900
Double-bellows actuator		500	1100	1500	2300	3000	4800	6900

Bellows actuator EB

Technical data

Materials

Sectional view

EB-80

EB-145 ... 385

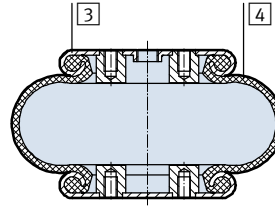
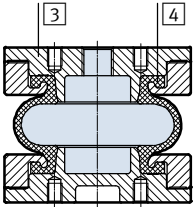

Size	80	145	165	215	250	325	385
3 Housing	Die-cast aluminium	Galvanised steel					
4 Bellows	CR	NR/BR					
- Note on materials	Free of copper and PTFE						
	RoHS-compliant						

Forces [N]

Size	80	145	165	214	250	325	385
Single-bellows actuator							
Force/stroke characteristics	→ 6						
Resetting force	400	120	200	200	200	300	300
Double-bellows actuator							
Force/stroke characteristics	→ 8						
Resetting force	200	200	200	200	200	300	400

- Note

- Bellows actuators may only be driven against a workpiece, or they must be equipped with stroke limiting stops at the stroke ends, because the bellows walls would otherwise be overloaded or internal damage could occur.
- A resetting force is required to press the bellows actuator together to its minimum height. As a rule, this is achieved through the weight force
- The entire bearing surfaces of the upper and lower plates must be utilised to absorb forces
- Bellows actuators must be exhausted before disassembly
- The walls of bellows actuators must not come into contact with other parts during operation

Bellows actuator EB

Technical data



Thrust F and bellows volume V as a function of the stroke length H

The diagram illustrates the change in thrust F with various working pressures and differing bellows volumes V in relation to the stroke length. The minimum installation height H_{min} must be observed to fully reach the indicated forces.

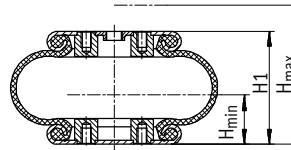

Single-bellows actuator

EB-80-20

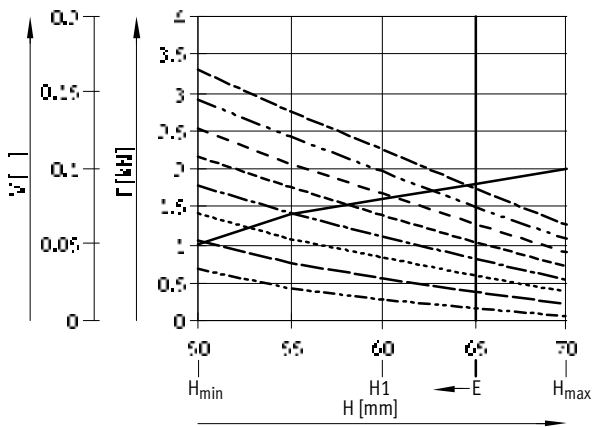

EB-145-60

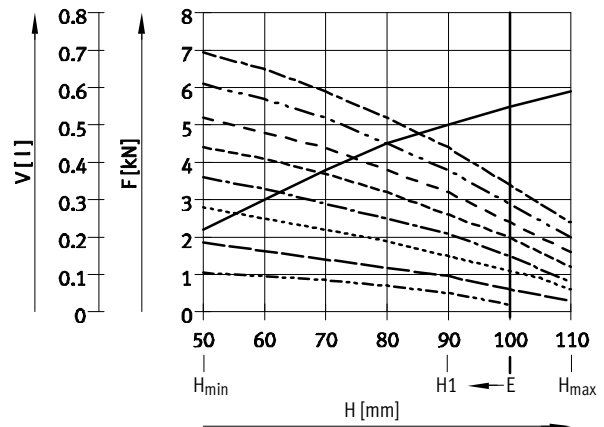

EB-165-65

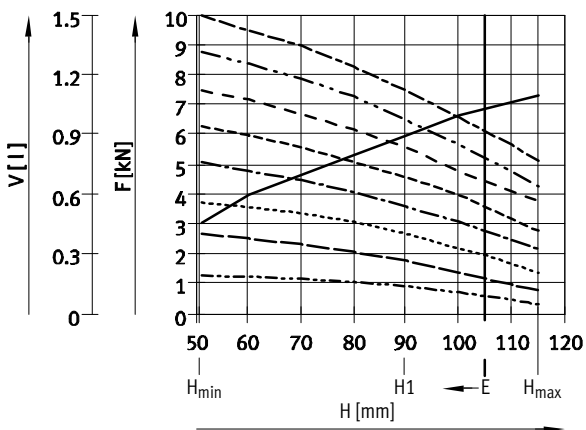

EB-215-80

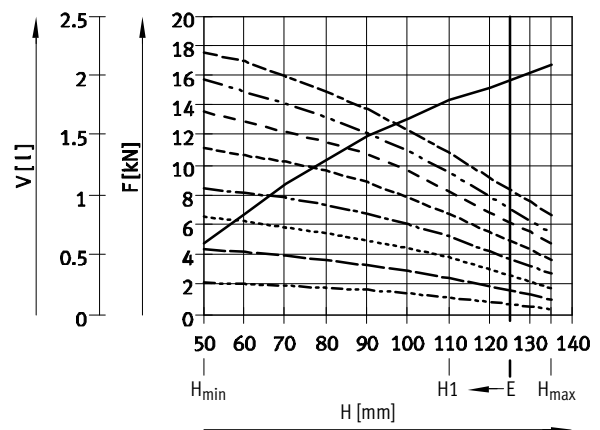

H1 Recommended operating height for cushioning application at 6 bar
 H_{min} Min. installation height
 H_{max} Max. extended height

← E Preferred range of application:
 Outside this range, the force reduces to a level so that the use of the next largest size is recommended.

- Volume
- 1 bar
- - - - - 2 bar
- 3 bar
- - - - - 4 bar
- - - - - 5 bar
- - - - - 6 bar
- - - - - 7 bar
- - - - - 8 bar

Bellows actuator EB

Technical data

Thrust F and bellows volume V as a function of the stroke length H

The diagram illustrates the change in thrust F with various working pressures and differing bellows volumes V in relation to the stroke length. The minimum installation height H_{min} must be observed to fully reach the indicated forces.

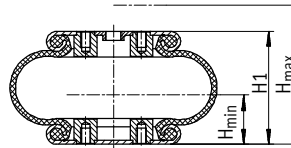

Single-bellows actuator

EB-250-85

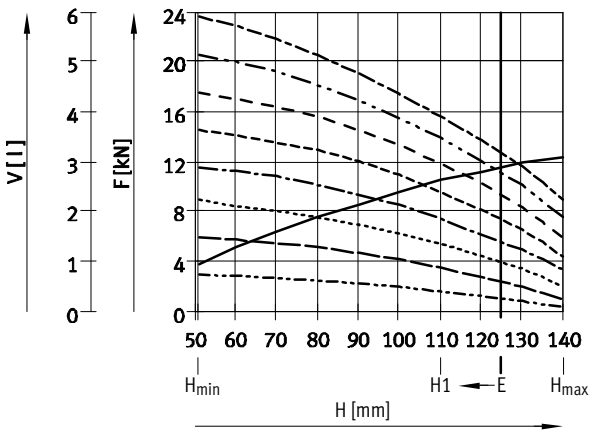

EB-325-95

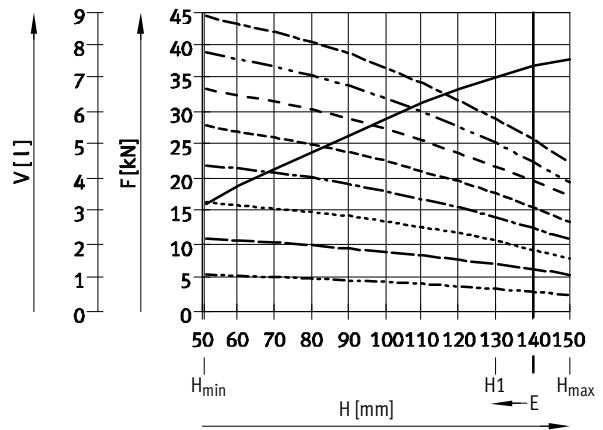

EB-385-115

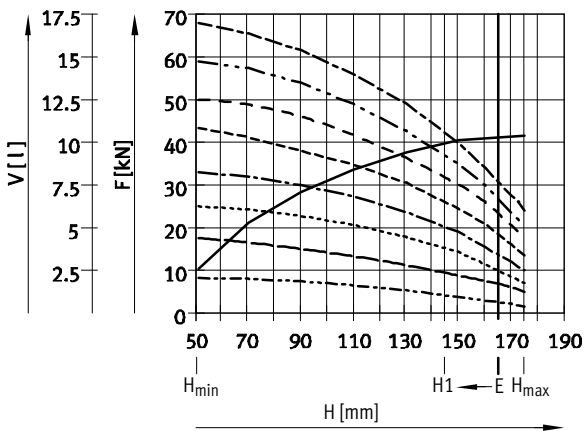

H1 Recommended operating height for cushioning application at 6 bar
 H_{min} Min. installation height
 H_{max} Max. extended height

← E Preferred range of application:
 Outside this range, the force reduces to a level so that the use of the next largest size is recommended.

- Volume
- - - 1 bar
- · - 2 bar
- · - 3 bar
- · - 4 bar
- · - 5 bar
- · - 6 bar
- · - 7 bar
- · - 8 bar

Bellows actuator EB

Technical data



Thrust F and bellows volume V as a function of the stroke length H

The diagram illustrates the change in thrust F with various working pressures and differing bellows volumes V in relation to the stroke

length. The minimum installation height H_{min} must be observed to fully reach the indicated forces.

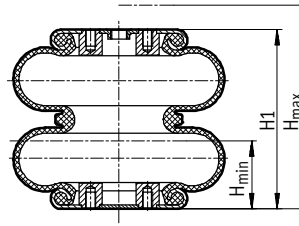

Double-bellows actuator

EB-80-45

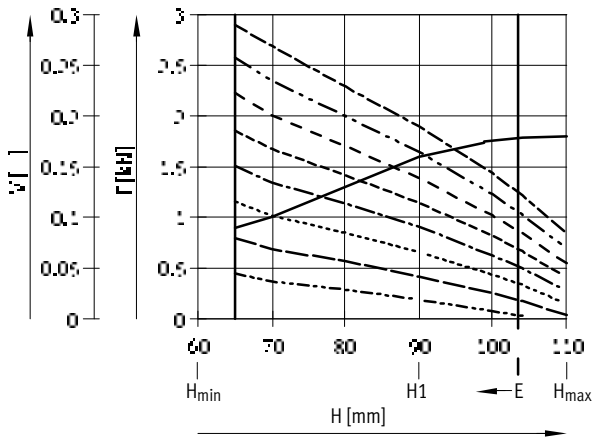

EB-145-100

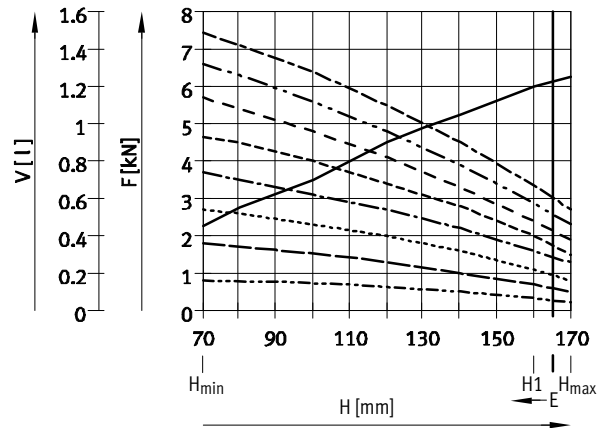

EB-165-125

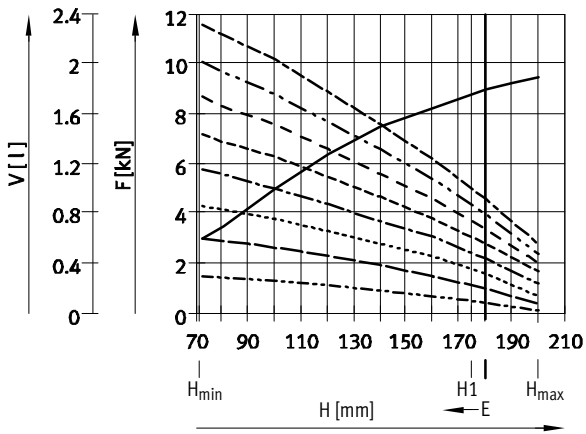

EB-215-155

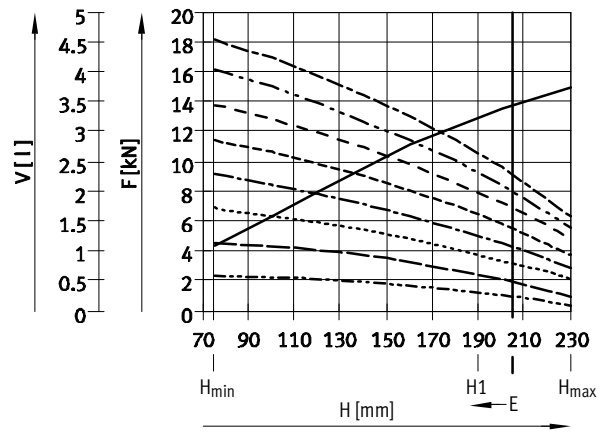

H1 Recommended operating height for cushioning application at 6 bar
 H_{min} Min. installation height
 H_{max} Max. extended height

← E Preferred range of application:
 Outside this range, the force reduces to a level so that the use of the next largest size is recommended.

— Volume
 - - - 1 bar
 - - - 2 bar
 - - - 3 bar
 - - - 4 bar
 - - - 5 bar

- - - 6 bar
 - - - 7 bar
 - - - 8 bar

Bellows actuator EB

Technical data



Thrust F and bellows volume V as a function of the stroke length H

The diagram illustrates the change in thrust F with various working pressures and differing bellows volumes V in relation to the stroke

length. The minimum installation height H_{min} must be observed to fully reach the indicated forces.

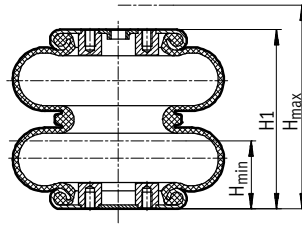

Double-bellows actuator

EB-250-185

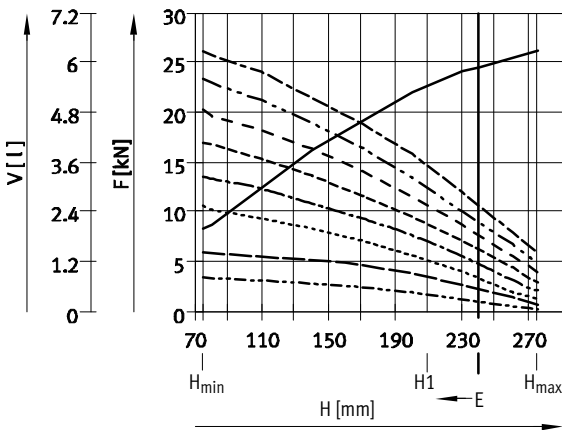

EB-325-215

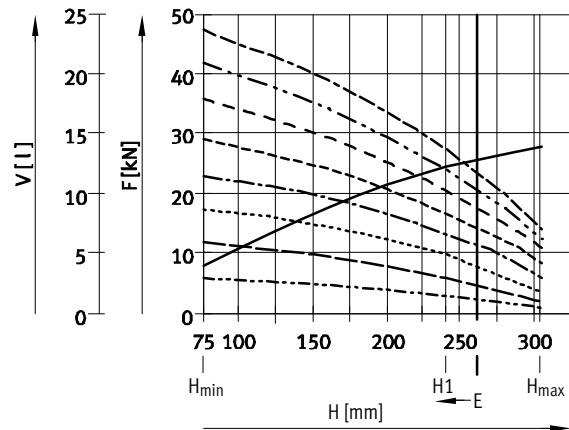

EB-385-230

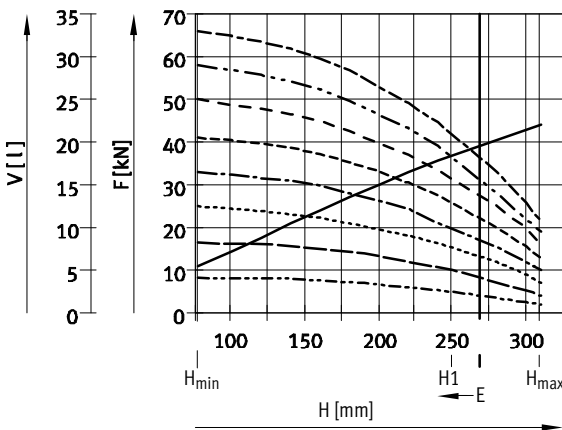

H1 Recommended operating height for cushioning application at 6 bar

H_{min} Min. installation height
 H_{max} Max. extended height

← E Preferred range of application: Outside this range, the force reduces to a level so that the use of the next largest size is recommended.

— Volume
- - - 1 bar
- · - 2 bar

- - - 3 bar
- · - 4 bar
- · - 5 bar

- - - 6 bar
- · - 7 bar
- · - 8 bar

Bellows actuator EB

Technical data

Dimensions

Download CAD data → www.festo.com

Single-bellows actuator – EB-80

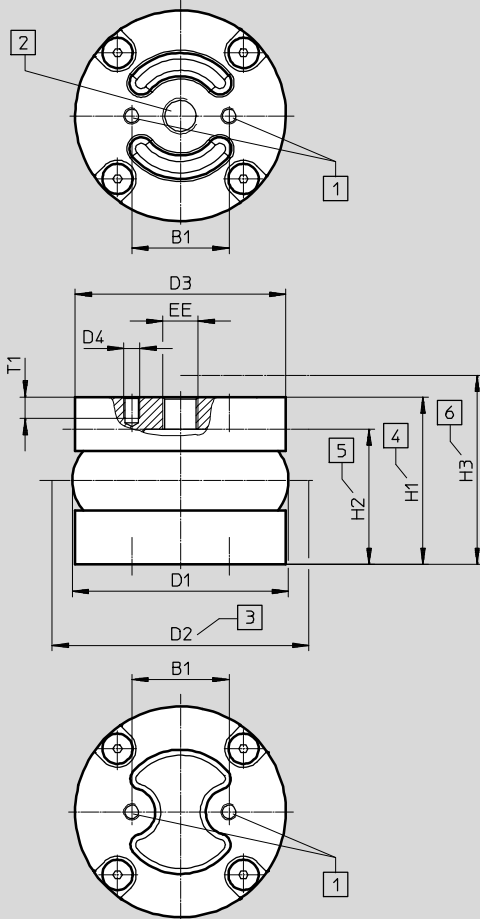

Max. offset between mounting surfaces:

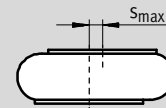

The stroke of the bellows actuator can be made to carry out a circular path, in which case the indicated tilt angle α must not be exceeded. During setup it must be ensured that the minimum height H_{min} is observed, and that the maximum height H_{max} is not exceeded at any given point.

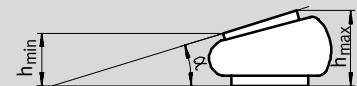

- 1 Fastening thread
- 2 Supply port
- 3 Required installation space
- 4 Recommended operating height
- 5 Min. installation height
- 6 Max. extended height

Type	B1	D1 Ø max.	D2 Ø	D3 Ø	D4	EE
EB-80-20	36	80	95	78	M6	G¼

Type	H1	H2 Min.	H3 Max.	T1 Min.	S _{max}	Tilt angle α max.
EB-80-20	60	50	70	8	5	10°

Bellows actuator EB

Technical data

Dimensions

Download CAD data → www.festo.com

Single-bellows actuator – EB-145 ... 385

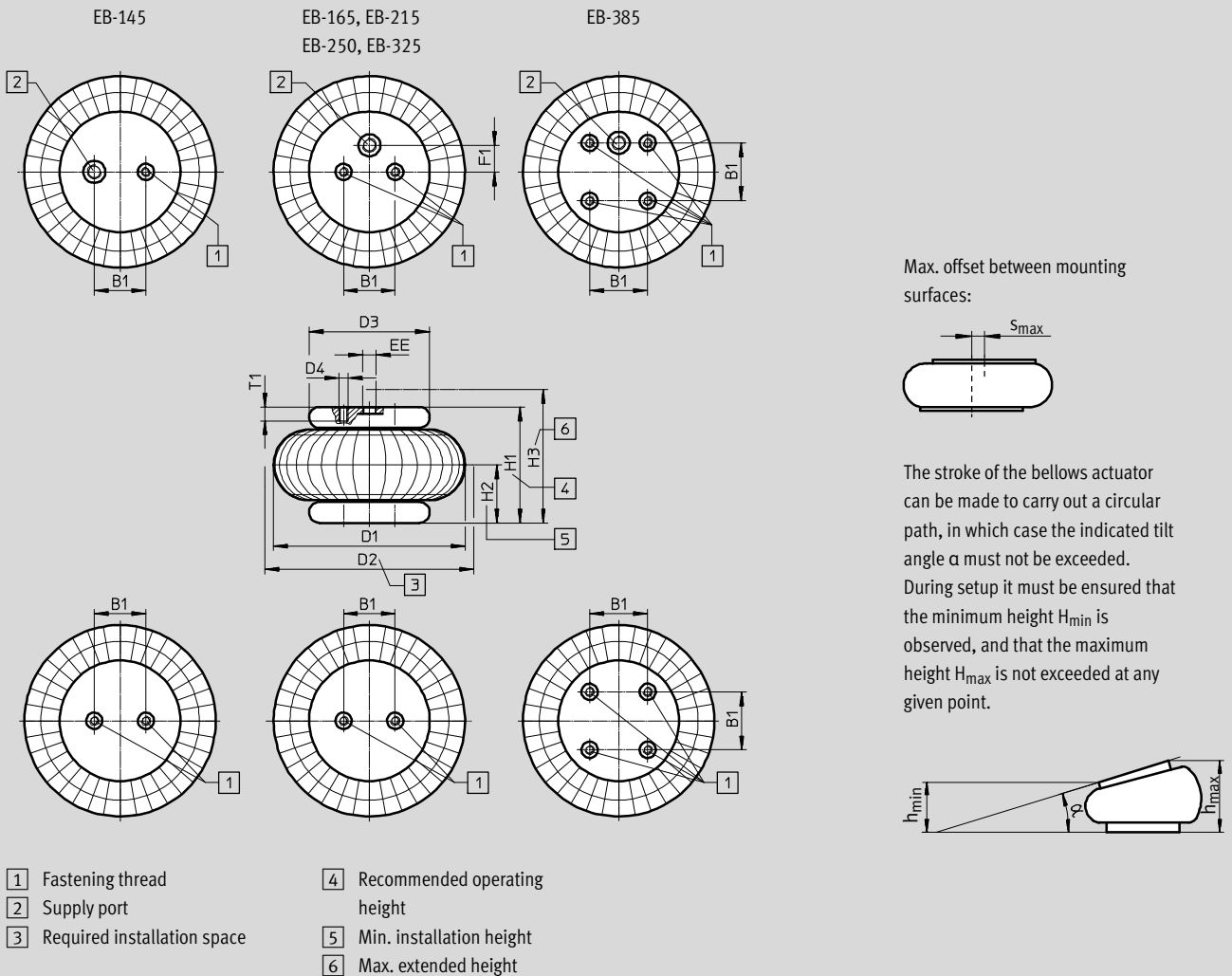

Type	B1	D1	D2	D3	D4	EE	F1
	±0.2	∅ max.	∅	∅			±0.2
EB-145-60	20	145	160	90	M8	G1/8	–
EB-165-65	44.5	165	180	108	M8	G1/4	0
EB-215-80	70	215	230	141	M8	G3/4	0
EB-250-85	89	250	265	161	M8	G3/4	38.1
EB-325-95	157.5	325	340	228	M8	G1/4	73
EB-385-115	158.8	385	400	287	M8	G1/4	79.4

Type	H1	H2	H3	T1	S _{max}	Tilt angle α max.
		Min.	Max.	Min.		
EB-145-60	90	50	110	15	10	20°
EB-165-65	90	51	115	15	10	20°
EB-215-80	110	50	135	15	10	20°
EB-250-85	110	51	140	15	10	20°
EB-325-95	130	51	150	15	10	15°
EB-385-115	145	51	175	15	10	15°

Bellows actuator EB

Technical data

Dimensions

Download CAD data → www.festo.com

Double-bellows actuator – EB-80

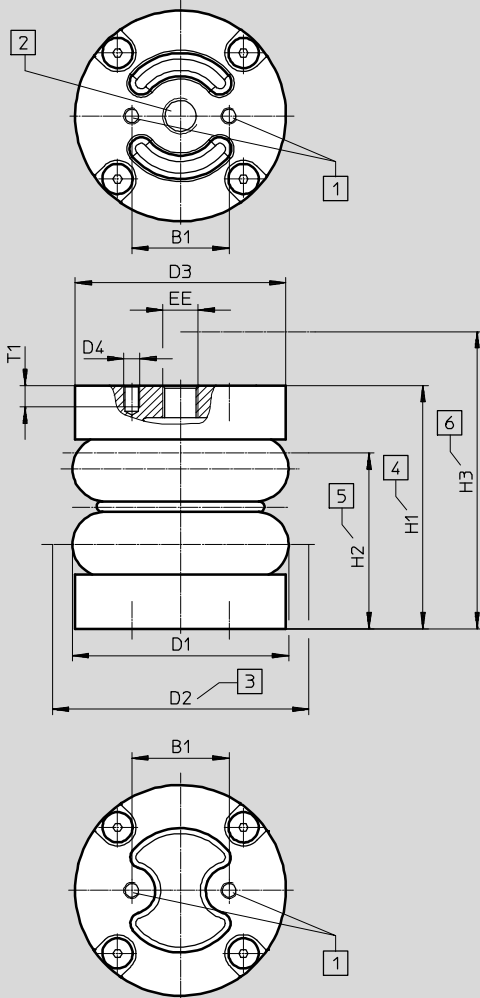

- 1 Fastening thread
- 2 Supply port
- 3 Required installation space
- 4 Recommended operating height
- 5 Min. installation height
- 6 Max. extended height

Max. offset between mounting surfaces:

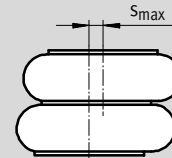

The stroke of the bellows actuator can be made to carry out a circular path, in which case the indicated tilt angle α must not be exceeded. During setup it must be ensured that the minimum height h_{min} is observed, and that the maximum height h_{max} is not exceeded at any given point.

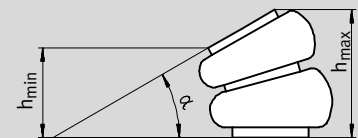

Type	B1	D1 ∅ max.	D2 ∅	D3 ∅	D4	EE
EB-80-45	36	80	95	78	M6	G¼

Type	H1	H2 Min.	H3 Max.	T1 Min.	S _{max}	Tilt angle α max.
EB-80-45	90	65	110	8	10	15°

Bellows actuator EB

Technical data

Dimensions

Download CAD data → www.festo.com

Double-bellows actuator – EB-145 ... 385

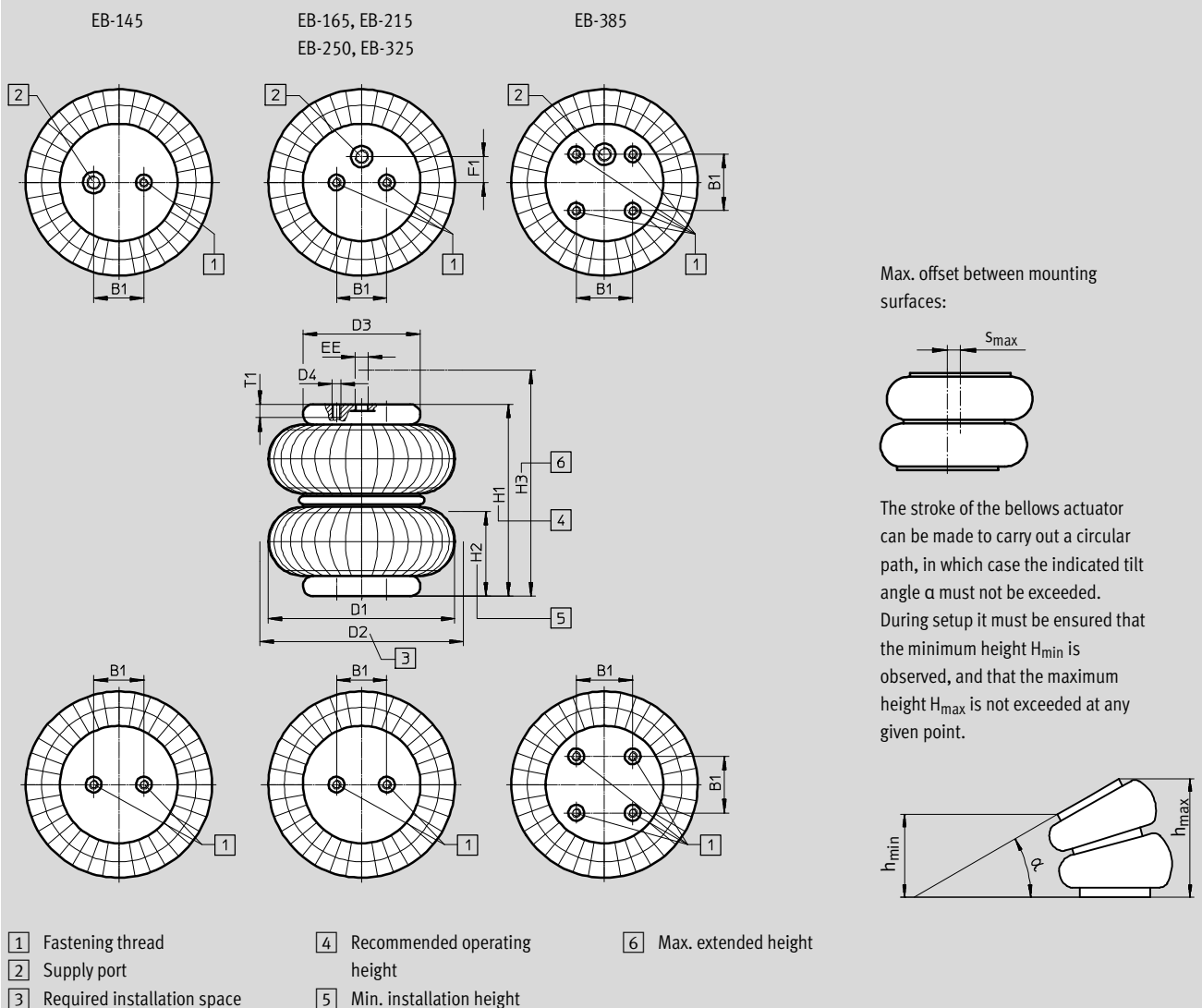





Type	B1	D1 ∅ max.	D2 ∅	D3 ∅	D4	EE	F1 ±0.2
EB-145-100	±0.2	145	160	90	M8	G1/8	–
EB-165-125	44.5	165	180	108	M8	G1/4	0
EB-215-155	70	215	230	141	M8	G3/4	0
EB-250-185	89	250	265	161	M8	G3/4	38.1
EB-325-215	157.5	325	340	228	M8	G1/4	73
EB-385-230	158.8	385	400	287	M8	G1/4	79.4

Type	H1	H2 Min.	H3 Max.	T1 Min.	S _{max}	Tilt angle α max.
EB-145-100	160	70	170	15	20	30°
EB-165-125	175	72	200	15	20	30°
EB-215-155	190	75	230	15	20	30°
EB-250-185	210	75	275	15	20	25°
EB-325-215	240	75	305	15	20	20°
EB-385-230	250	77	310	15	20	20°

Bellows actuator EB

Technical data

Ordering data				
Type	Size	Stroke [mm]	Part No.	Type
Single-bellows actuator				
	80	20	2748903	EB-80-20
	145	60	36486	EB-145-60
	165	65	36487	EB-165-65
	215	80	36488	EB-215-80
	250	85	36489	EB-250-85
	325	95	193788	EB-325-95
	385	115	193789	EB-385-115
Double-bellows actuator				
	80	45	2748904	EB-80-45
	145	100	36490	EB-145-100
	165	125	36491	EB-165-125
	215	155	36492	EB-215-155
	250	185	36493	EB-250-185
	325	215	193790	EB-325-215
	385	230	193791	EB-385-230

Product Range and Company Overview

A Complete Suite and Company Overview

Our experienced engineers provide complete support at every stage of your development process, including: conceptualization, analysis, engineering, design, assembly, documentation, validation, and production.

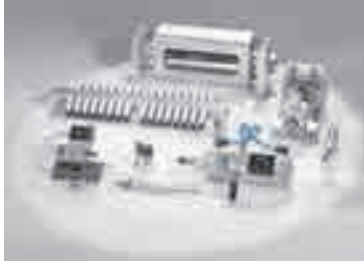

Custom Automation Components
Complete custom engineered solutions



Custom Control Cabinets
Comprehensive engineering support and on-site services

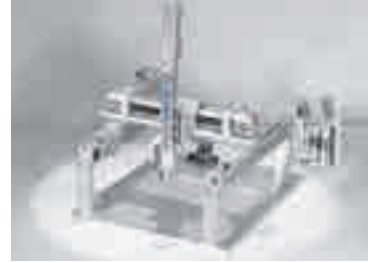

Complete Systems
Shipment, stocking and storage services

The Broadest Range of Automation Components

With a comprehensive line of more than 30,000 automation components, Festo is capable of solving the most complex automation requirements.



Electromechanical
Electromechanical actuators, motors, controllers & drivers



Pneumatics
Pneumatic linear and rotary actuators, valves, and air supply



PLCs and I/O Devices
PLC's, operator interfaces, sensors and I/O devices

Supporting Advanced Automation... As No One Else Can!

Festo is a leading global manufacturer of pneumatic and electromechanical systems, components and controls for industrial automation, with more than 16,000 employees in 60 national headquarters serving more than 180 countries. For more than 80 years, Festo has continuously elevated the state of manufacturing with innovations and optimized motion control solutions that deliver higher performing, more profitable automated manufacturing and processing equipment. Our dedication to the advancement of automation extends beyond technology to the education and development of current and future automation and robotics designers with simulation tools, teaching programs, and on-site services.

Quality Assurance, ISO 9001 and ISO 14001 Certifications

Festo Corporation is committed to supply all Festo products and services that will meet or exceed our customers' requirements in product quality, delivery, customer service and satisfaction.

To meet this commitment, we strive to ensure a consistent, integrated, and systematic approach to management that will meet or exceed the requirements of the ISO 9001 standard for Quality Management and the ISO 14001 standard for Environmental Management.



© Copyright 2013, Festo Corporation. While every effort is made to ensure that all dimensions and specifications are correct, Festo cannot guarantee that publications are completely free of any error, in particular typing or printing errors. Accordingly, Festo cannot be held responsible for the same. For Liability and Warranty conditions, refer to our "Terms and Conditions of Sale", available from your local Festo office. All rights reserved. No part of this publication may be reproduced, distributed, or transmitted in any form or by any means, electronic, mechanical, photocopying or otherwise, without the prior written permission of Festo. All technical data subject to change according to technical update.



Printed on recycled paper at New Horizon Graphic, Inc., FSC certified as an environmental friendly printing plant.

Festo North America

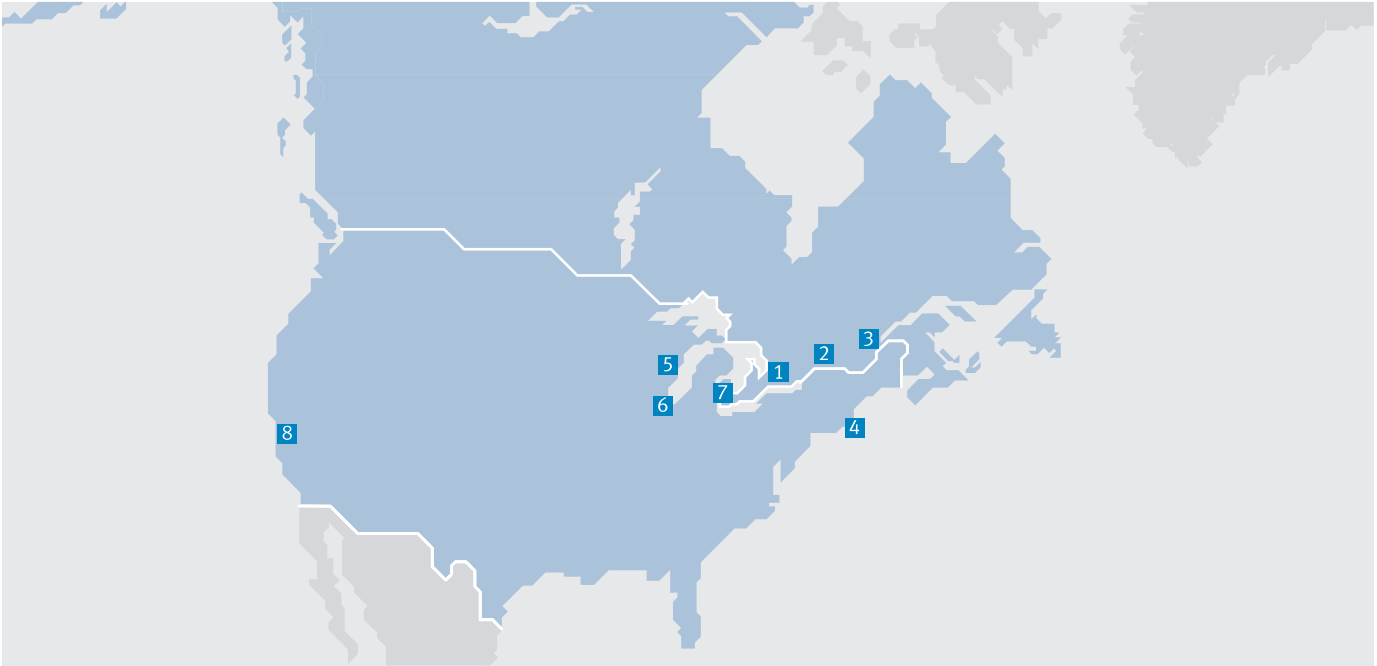

**1 Festo Canada
Headquarters
Festo Inc.**
5300 Explorer Drive
Mississauga, ON
L4W 5G4

2 Montréal
5600, Trans-Canada
Pointe-Claire, QC
H9R 1B6

3 Québec City
2930, rue Watt#117
Québec, QC
G1X 4G3



**4 Festo United States
Headquarters
Festo Corporation**
395 Moreland Road
Hauppauge, NY
11788

5 Appleton
North 922 Tower View Drive, Suite N
Greenville, WI
54942

7 Detroit
1441 West Long Lake Road
Troy, MI
48098

6 Chicago
85 W Algonquin - Suite 340
Arlington Heights, IL
60005

8 Silicon Valley
4935 Southfront Road, Suite F
Livermore, CA
94550

Festo Regional Contact Center

Canadian Customers

Commercial Support:
Tel: 1 877 GO FESTO (1 877 463 3786)
Fax: 1 877 FX FESTO (1 877 393 3786)
Email: festo.canada@ca.festo.com

Technical Support:

Tel: 1 866 GO FESTO (1 866 463 3786)
Fax: 1 877 FX FESTO (1 877 393 3786)
Email: technical.support@ca.festo.com

USA Customers

Commercial Support:
Tel: 1 800 99 FESTO (1 800 993 3786)
Fax: 1 800 96 FESTO (1 800 963 3786)
Email: customer.service@us.festo.com

Technical Support:

Tel: 1 866 GO FESTO (1 866 463 3786)
Fax: 1 800 96 FESTO (1 800 963 3786)
Email: product.support@us.festo.com