



- Wide variety of mounting options
- Infinitely adjustable swivel angle
- Comprehensive range of accessories

Semi-rotary drives DSR/DSRL

Features

FESTO

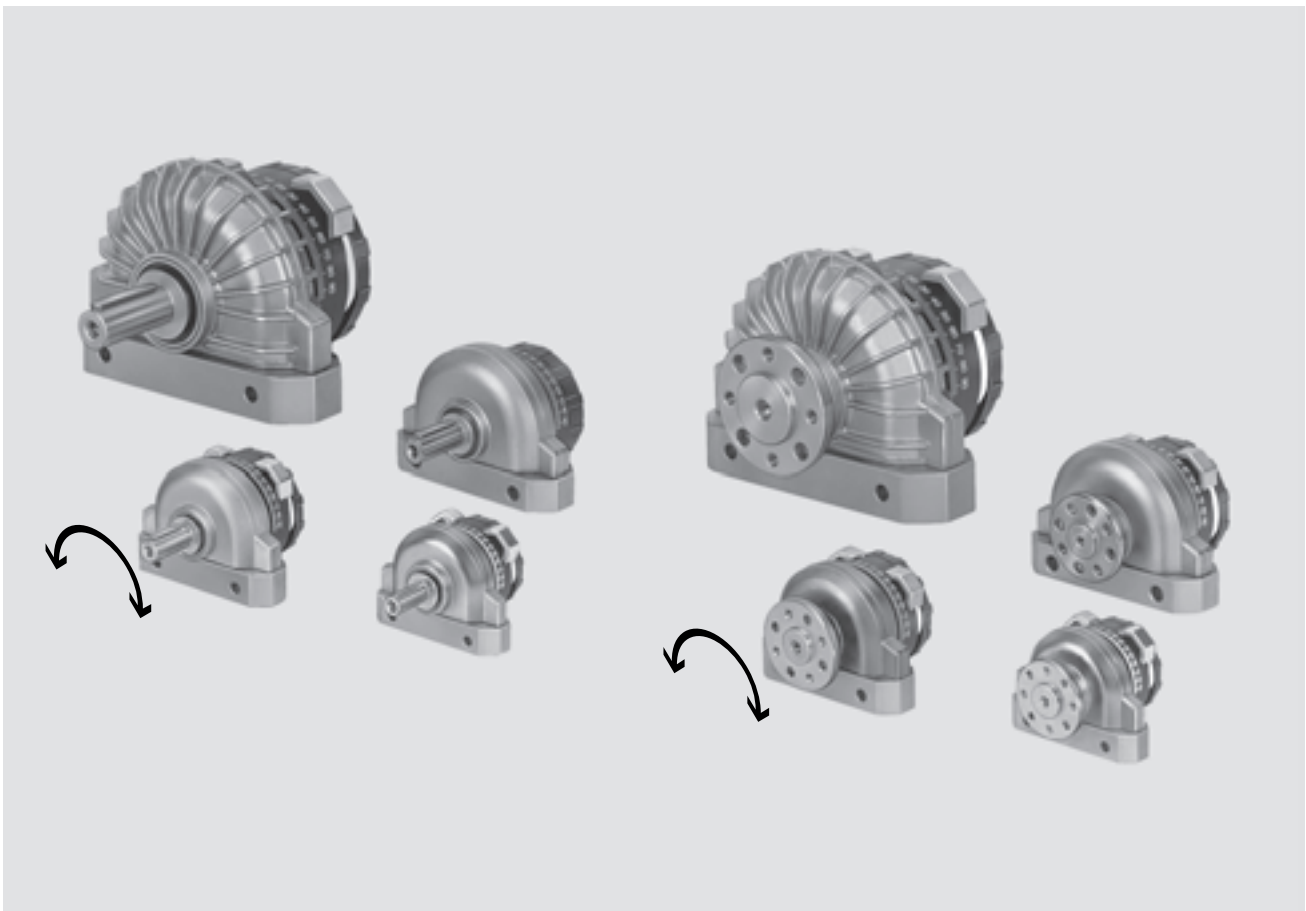

Brief description

In these semi-rotary drives, the force is directly transmitted to the drive shaft via a rotary vane. The swivel angle is infinitely adjustable from 0 ... 184° (DSRL-10 and 12: 0 ... 181°).

The adjustable stop system is separate from the rotary vane so that any forces which occur are absorbed by the stop blocks. The impacts are cushioned at the end positions by flexible plastic plates.

DSRL-...-FW
This design with hollow flanged shaft permits the passage of liquid or gaseous media, or even tubing or

wiring. The force is transmitted directly and backlash-free via a splined shaft.

-  - Note
Sizing software
Calculating inertia
→ www.festo.com

Semi-rotary drives DSR/DSRL

Features

Mounting options

Without mounting attachments

Direct mounting

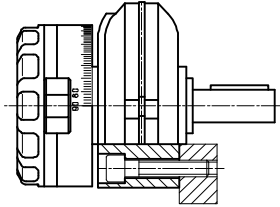

With mounting attachments for DSR

Foot mounting HSR-...-FW



Flange mounting FSR



Push-on flange FWSR



for DSRL

Foot mounting HSR-...-FW



Freewheel unit for synchronous movements

The freewheel unit is an attachment which is fitted to the drive shaft of the semi-rotary drive DSR. The freewheel unit converts the oscillating rotary movement of the semi-rotary drive into a synchronous, indexing movement. The movement of the semi-rotary drive shaft only occurs in the working directions left or right. This permits infinitely adjustable feed movements.

The minimum possible swivel angle is 0.4°. Switching accuracy is also dependent upon switching speed and load.

-  Note

The load must be stopped externally!

FLSR-...-L (left-hand)
Viewed from the drive shaft side, rotation counter-clockwise.

FLSR-...-R (right-hand)
Viewed from the drive shaft side, rotation clockwise.

Accessories
Speed regulation

→ 20

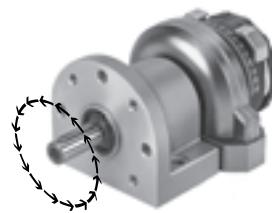

FLSR with semi-rotary drive

Sample applications with hollow flanged shaft in DSRL

Air blast

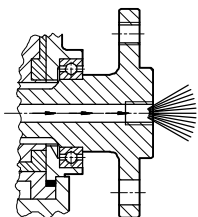

Vacuum

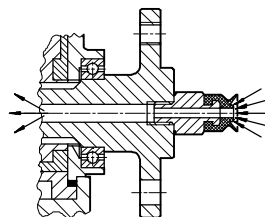

Electrical lines

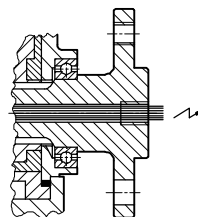

Water, coolant, oil, glue, etc.

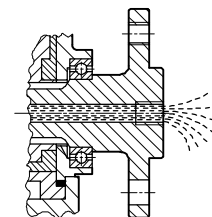

Semi-rotary drives DSR/DSRL

Peripherals overview and type codes

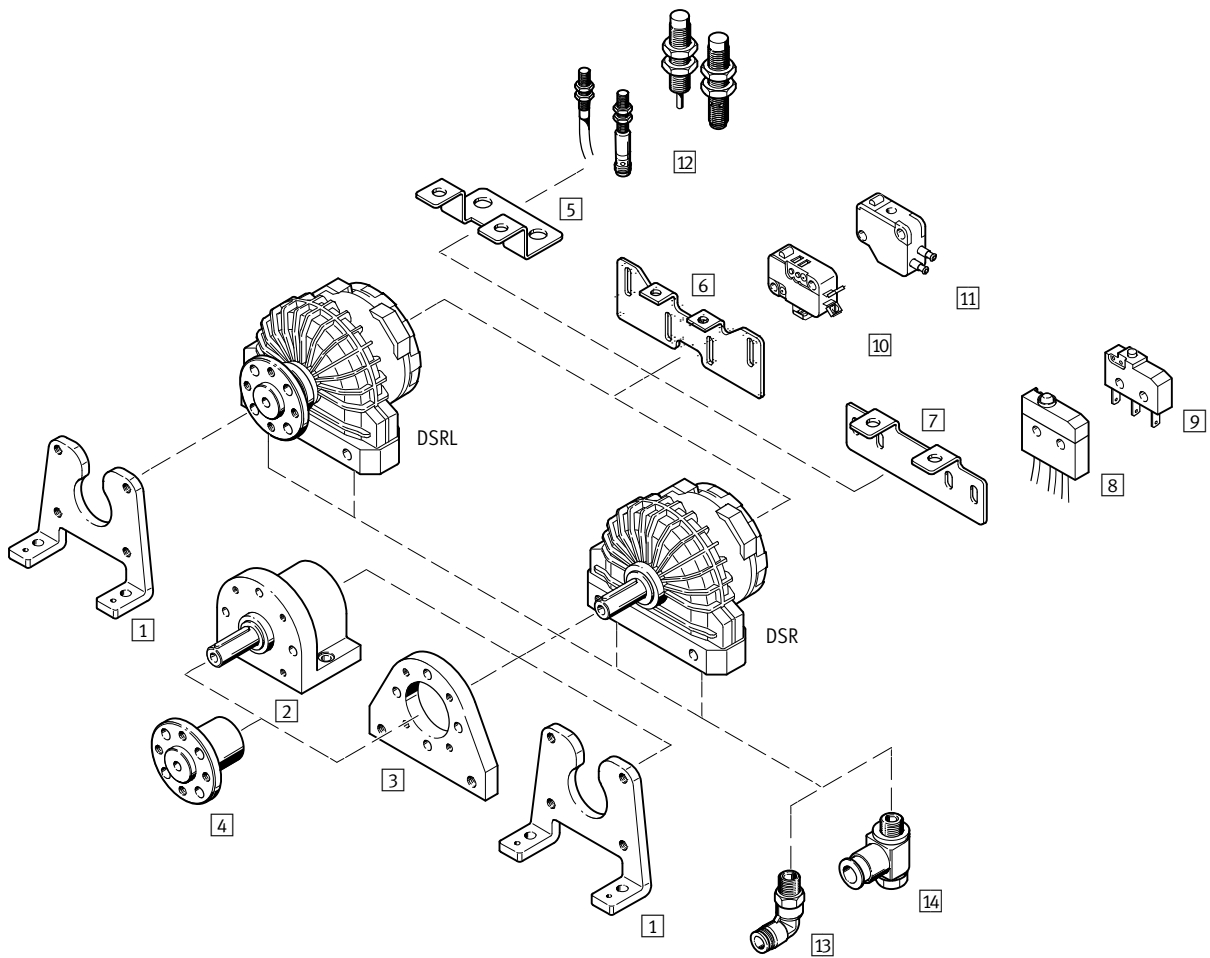

Semi-rotary drives DSR/DSRL

Peripherals overview and type codes

Mounting attachments and accessories				
	Description	DSR	DSRL	→ Page/Internet
1	Foot mounting HSR-...-FW	■	■	12
2	Freewheel unit FLSR-...-L/R	■	-	14
3	Flange mounting FSR	■	-	12
4	Push-on flange FWSR	■	-	13
5	Mounting kit WSR-...	■	■	17
6	Mounting kit WSR-12 ... 40	■	■	16
7	Mounting kit WSR-10/12-K	■	■	16
8	Micro switch S-3-BE-SW	■	■	19
9	Micro switch S-3-BE	■	■	19
10	Micro switch S-3-E	■	■	19
11	Micro stem actuated valve SO-3-PK-3-B, S-3-PK-3-B	■	■	20
12	Proximity sensors SIEN	■	■	20
13	Push-in L-fitting QSL	■	■	quick star
14	One-way flow control valve GRLA	■	■	20

DSRL		-	10	-	180	-	P	-	FW
Type									
Double-acting									
DSR	Semi-rotary drive with spigot shaft								
DSRL	Semi-rotary drive, with flanged, hollow drive shaft								
Piston Ø [mm]									
Swivel angle [°]									
Cushioning									
P	Non-adjustable at either end								
Shaft									
	Spigot shaft								
FW	Drive shaft								

Semi-rotary drives DSR/DSRL

Technical data

Function

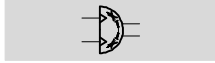

Variants

- With spigot shaft
- With hollow flanged shaft

- Ø - Diameter
10 ... 40 mm

- ≡ - Force
0.5 ... 20 Nm

- T - www.festo.com



General technical data						
Piston Ø	10	12	16	25	32	40
Pneumatic connection	M3	M5	M5	M5	G $\frac{1}{8}$	G $\frac{1}{4}$
Design	Semi-rotary actuator with vane drive					
Cushioning	Non-adjustable at either end					
Position sensing	Electrical					
	Pneumatic					
	Inductive					
Type of mounting	Via through-holes					
	Via accessories					
Mounting position	Any					
Max. swivel angle	0 ... 181 °		0 ... 184 °			

- | - Note: This product conforms to ISO 1179-1 and to ISO 228-1

Operating and environmental conditions						
Piston Ø	10	12	16	25	32	40
Operating medium	Compressed air in accordance with ISO 8573-1:2010 [7:--:--]					
Operating pressure [bar]	2.5 ... 8		2 ... 8		1.5 ... 8	
Temperature range ¹⁾ [°C]	-10 ... +60					

1) Note operating range of proximity sensors

Forces and torques						
Piston Ø	10	12	16	25	32	40
Torque at 6 bar [Nm]	0.5	1	2	5	10	20
Max. swivelling frequency ¹⁾ [Hz]	3					
Max. perm. radial load ²⁾ [N]	30	45	75	120	200	350
Max. perm. axial load ²⁾ [N]	10	18	30	50	75	120
Max. perm. mass moment of inertia ²⁾	Diagrams → 8					

- 1) Please observe the max. permissible mass moments of inertia → 8
 2) On the drive shaft at maximum frequency

Semi-rotary drives DSR/DSRL

Technical data

Materials

Sectional view

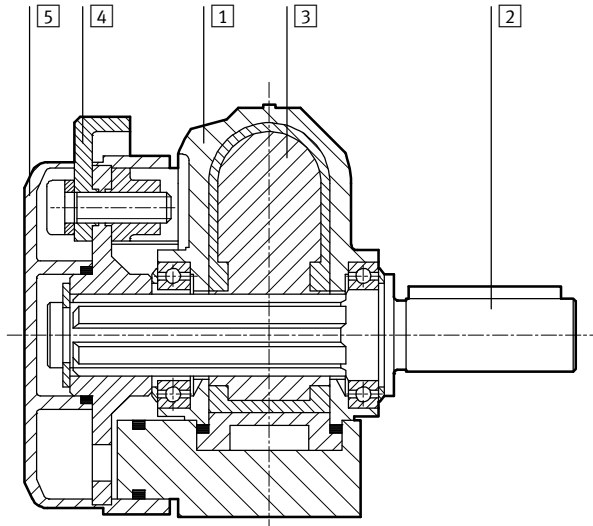

Rotary actuator		
1	Housing	Die-cast zinc
2	Drive shaft	Nickel plated steel
3	Rotary vane	Plastic
4	Trip cam	Sintered steel, nickel plated
5	Cover cap	Plastic
-	Seals	Nitrile rubber

Weights [g]						
Piston Ø	10	12	16	25	32	40
DSR-...-P	100	200	310	540	1285	2400
DSRL-...-FW	140	240	350	610	1390	2700

Semi-rotary drives DSR/DSRL

Technical data



Max. permissible mass moment of inertia

Mass moment of inertia m as a function of swivel time S and swivel angle

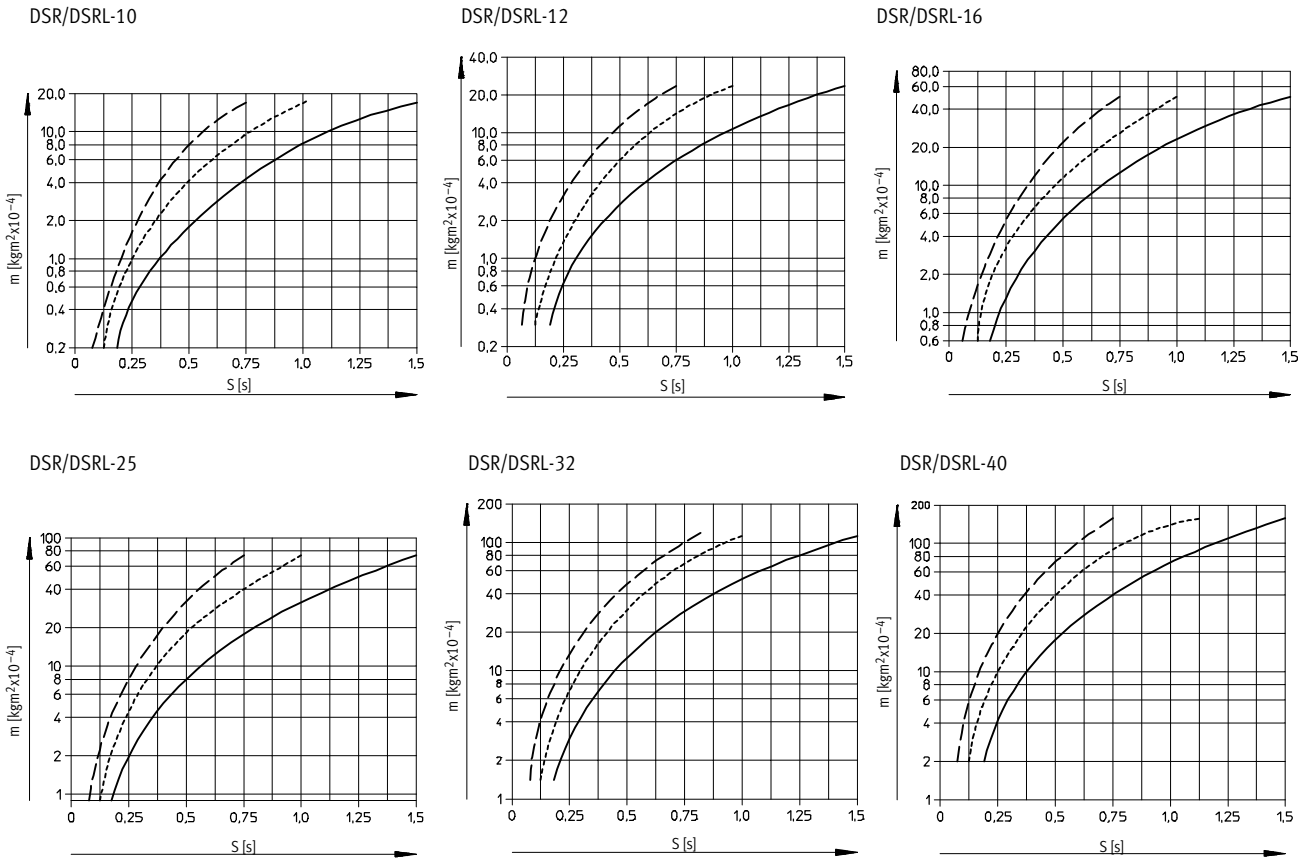

- - Note
Sizing software
Calculating inertia
→ www.festo.com

----- Swivel angle 90°
..... Swivel angle 120°
———— Swivel angle 180°

Assembly instructions:

If the listed maximum permissible mass moment of inertia is exceeded, external stops must be attached. Please note: The stop must not be less than the minimum radius to the drive shaft (r_{min}). The stop force must not exceed

the maximum force. Due to the flexibility of the stops, a precise end position can only be achieved using external stops.

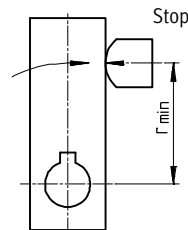

Ø [mm]	Stop radius r_{min} [mm]	Force [N]
10	13	60
12	15	90
16	17	160
25	21	320
32	28	480
40	40	650

- - Note
When throttling the semi-rotary drives to swivelling speeds under 180°/s, the drives must be operated at a pressure of at least 6 bar. A constant speed fluctuation of $\pm 30\%$ is to be expected. The flutters and the swivelling times shown in the diagrams can only be improved by using flow control valves.

Semi-rotary drives DSR/DSRL

Technical data

FESTO

Dimensions

Download CAD data → www.festo.com

DSR

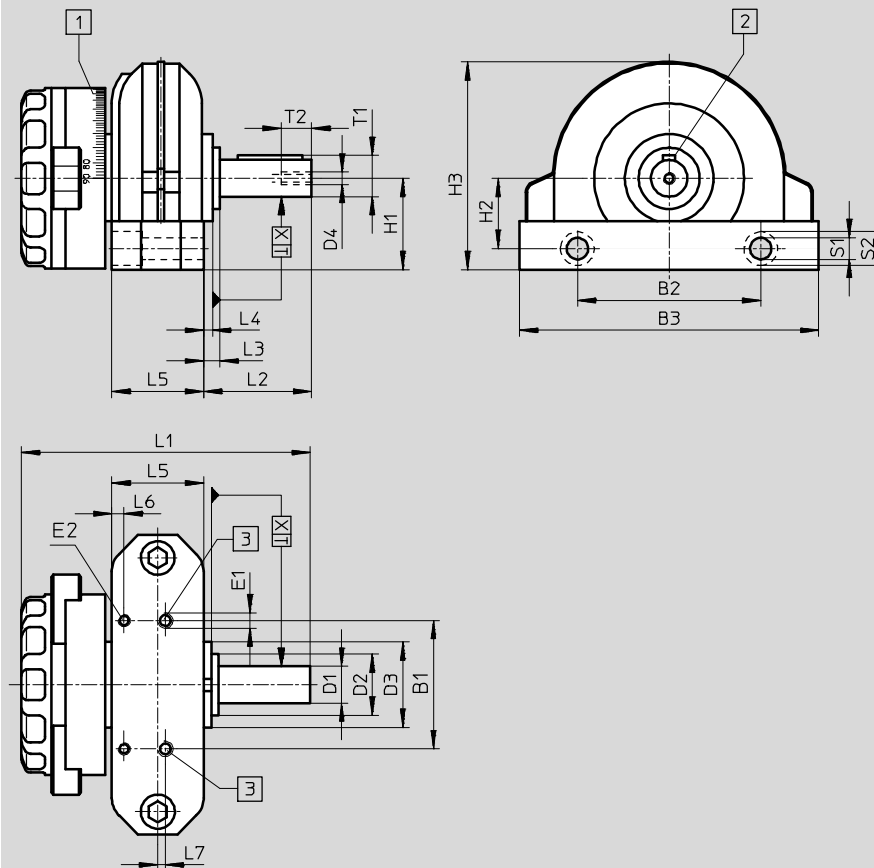

-  - Note

The swivel angle is 180° and pressure-dependent. The cushioning angle on each side is approx. 1.6° maximum at 8 bar.

If after the swivel process, the kinetic energy is converted by cushioning, the drive shaft swivels back by a corresponding angle.

The stops must not be removed as the rotary vane is not suitable for end-position limiting. The cover cap is equipped with an angle scale for adjusting.

When attaching additional components to the drive shaft, the maximum permissible tightening torque of the bolt at D4 must not be exceeded.

- 1 Angle scale for swivel angle reading 2 Woodruff key position at 0° 3 Supply port

∅	B1	B2	B3	D1	D2	D3	D4	E1	E2	H1	H2	H3	L1	L2
[mm]				∅ g7	∅	∅ h8								
10	22	32	53	6	12	20	M2.5	M3	M3	19.4	15.5	38.8	57	22.4
12	26	40	65	8	16	22	M3	M5	M3	23.5	18.5	48	65.6	25.5
16	30	46	78	10	17	24	M3	M5	M3	27	20.5	56.5	75.8	29
25	42	60	98	12	18	28	M4	M5	M4	30	23	68.1	94.5	35.4
32	54	80	130	16	27	42	M5	G1/8	M4	43	34	92	125.5	50
40	70	100	160	20	36	52	M6	G1/4	M4	53	40	121	162	60

∅	L3	L4	L5	L6	L7	S1	S2	T1	T2	X	Woodruff key to DIN 6885 ¹⁾	Tightening torque at D4 [Nm]
[mm]												
10	6.5	4.5	15.1	2.2	2	3.4	6	6.8	7	0.35	A2 x 2 x 12	0.7
12	5.5	3.5	18	2.1	2.5	4.4	8	8.8	9	0.35	A2 x 2 x 16	1.2
16	6	3.5	22.5	2.1	-	5.5	10	11.2	9	0.35	A3 x 3 x 18	1.2
25	5.4	3	30	4	-	7	11	13.5	10	0.4	A4 x 4 x 25	5.5
32	10	7	36	4	-	8.5	15	18	12.5	0.45	A5 x 5 x 36	5.5
40	10	6	50	4	-	8.5	15	22.5	16	0.5	A6 x 6 x 45	5.5

1) included in scope of delivery

-  - Note: This product conforms to ISO 1179-1 and to ISO 228-1

Semi-rotary drives DSR/DSRL

Technical data

FESTO

Dimensions

Download CAD data → www.festo.com

DSRL

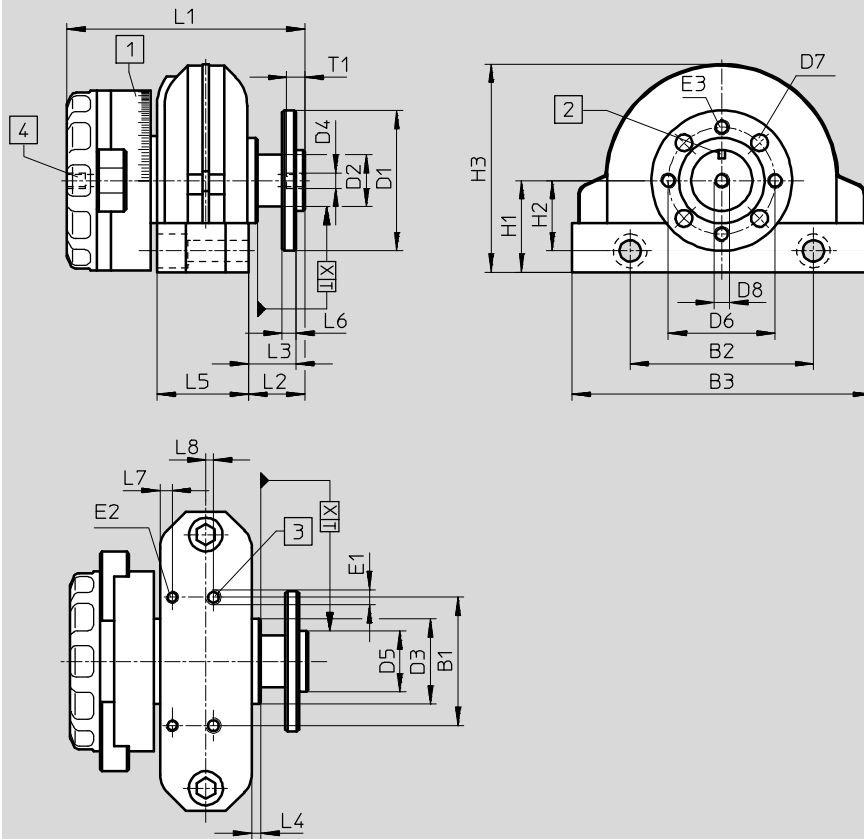

Note

The swivel angle is 180° and pressure-dependent. The cushioning angle on each side is approx. 1.6° maximum at 8 bar.

If after the swivel process, the kinetic energy is converted by cushioning, the drive shaft swivels back by a corresponding angle.

The stops must not be removed as the rotary vane is not suitable for end-position limiting. The cover cap is equipped with an angle scale for adjusting.

When attaching additional components to the drive flange, the maximum permissible tightening torque of the bolt at D4 must not be exceeded.

1 Angle scale for swivel angle reading

2 Position of marking at angle scale 0°

3 Supply port

4 Through-hole



∅	B1	B2	B3	D1	D2	D3	D4	D5	D6	D7	D8	E1	E2	E3	H1
[mm]				∅	∅	∅ h8		∅ f8	∅	∅ H13	∅ min.				
10	22	32	53	30	10	20	M3	11	21	3.4	1.5	M3	M3	M3	19.4
12	26	40	65	33	13	22	M3	14	25	3.4	1.5	M5	M3	M3	23.5
16	30	46	78	38	14	24	M5	16	28	4.5	3.5	M5	M3	M4	27
25	42	60	98	46	17	28	M5	20	35	5.5	3.5	M5	M4	M5	30
32	54	80	130	60	24	42	G1/8	28	45	6.5	7	G1/8	M4	M6	43
40	70	100	160	70	30	52	G1/8	36	54	9	7	G1/4	M4	M8	53

∅	H2	H3	L1	L2	L3	L4	L5	L6	L7	L8	S1	S2	T1	X	Tightening torque at D4 [Nm]
[mm]															
10	15.5	38.8	49	14	12.3	4.5	15.1	3	2.2	2	3.4	6	5	0.35	0.7
12	18.5	48	54.2	13.5	11.5	3.5	18	3	2.1	2.5	4.4	8	5	0.35	1.2
16	20.5	56.5	64.7	16	14	3.5	22.5	4	2.1	-	5.5	10	6	0.35	1.2
25	23	68.1	78	18.5	15.5	3	30	4.5	4	-	7	11	6	0.4	5.5
32	34	92	102.8	26	22	7	36	6	4	-	8.5	15	8	0.45	5.5
40	40	121	134.5	31	26	6	50	7.5	4	-	8.5	15	8	0.5	5.5

Note: This product conforms to ISO 1179-1 and to ISO 228-1

Semi-rotary drives DSR/DSRL

Technical data

Ordering data				
Rotary actuator	Design	∅ [mm]	Part No.	Type
DSR-...-P				
	With spigot shaft	10	33297	DSR-10-180-P
		12	11909	DSR-12-180-P
		16	11910	DSR-16-180-P
		25	11911	DSR-25-180-P
		32	11912	DSR-32-180-P
		40	13467	DSR-40-180-P
DSRL-...-P-FW				
	With hollow flanged shaft	10	33296	DSRL-10-180-P-FW
		12	30654	DSRL-12-180-P-FW
		16	30655	DSRL-16-180-P-FW
		25	30656	DSRL-25-180-P-FW
		32	30657	DSRL-32-180-P-FW
		40	30658	DSRL-40-180-P-FW

Semi-rotary drives DSR/DSRL

Accessories



Foot mounting HSR-...-FW

Material:
Steel

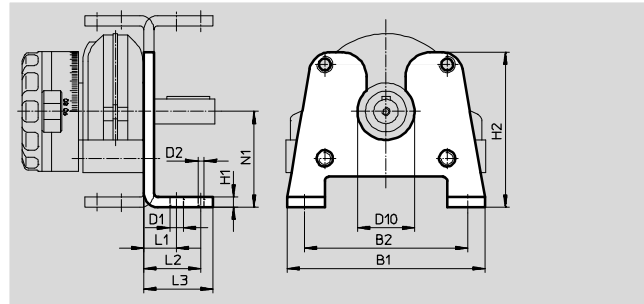

Dimensions and ordering data

For \varnothing [mm]	B1	B2	D1 \varnothing H13	D2	D10	H1	H2	L1	L2	L3	N1	CRC ¹⁾	Weight [g]	Part No.	Type
10	53.5	43	3.5	2	20	4	53	11	17	21	34	2	61	33317	HSR-10-FW
12	64	52	3.5	2	22	4	63	11	17	21	40	2	87	30923	HSR-12-FW
16	77	63	5.7	2	24	5	71	14	22	26.5	44	2	170	30924	HSR-16-FW
25	97	80	6.8	3	28	5	76	16	28	34	47	2	235	30925	HSR-25-FW
32	129	105	8.8	4	42	8	108	20	34	43	66	2	660	30926	HSR-32-FW
40	159	130	8.8	5	52	8	134	25	42	52	81	2	1040	30927	HSR-40-FW

1) Corrosion resistance class CRC 2 to Festo standard FN 940070

Moderate corrosion stress. Indoor applications in which condensation may occur. External visible parts with primarily decorative requirements for the surface and which are in direct contact with the ambient atmosphere typical for industrial applications.

Flange mounting FSR

Material:
Aluminium

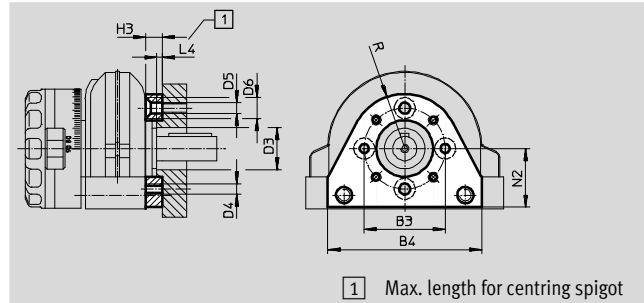

1) Max. length for centring spigot

Dimensions and ordering data

For \varnothing [mm]	B3	B4	D3 \varnothing min.	D4	D5 \varnothing H13	D6 \varnothing H13	H3	L4 max.	N2	R	CRC ¹⁾	Weight [g]	Part No.	Type
10	28	46	13	M3	3.4	6.5	7	2	20	18	2	22	34480	FSR-10
12	31	54	17	M3	3.4	6.5	7	2	22	20.5	2	32	14658	FSR-12
16	35	62	19	M4	4.5	8.5	8	2	26.5	23.5	2	50	13236	FSR-16
25	40	76	21	M5	5.5	10.4	8	2.5	29	27	2	70	13237	FSR-25
32	56	100	32	M6	6.6	12.4	12	2.5	42	36	2	180	13238	FSR-32
40	72	120	37	M8	9	16.4	14	4	52	46	2	300	14655	FSR-40

1) Corrosion resistance class CRC 2 to Festo standard FN 940070

Moderate corrosion stress. Indoor applications in which condensation may occur. External visible parts with primarily decorative requirements for the surface and which are in direct contact with the ambient atmosphere typical for industrial applications.

Semi-rotary drives DSR/DSRL

Accessories

Push-on flange FWSR

The permissible tightening torque may not be exceeded when installing the push-on flange FWSR on the drive shaft.

Material:

Wrought aluminium alloy, anodised
Copper, PTFE and silicone free

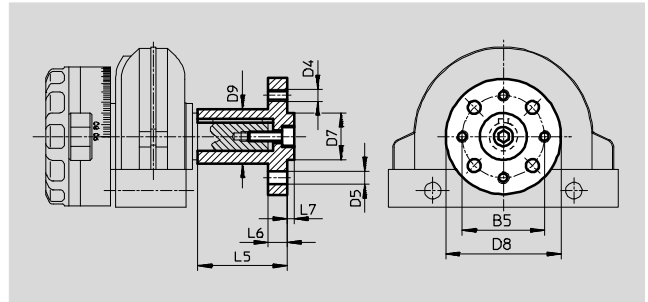
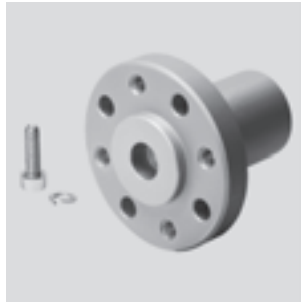

Dimensions and ordering data														
For \varnothing	B5	D4	D5 \varnothing H13	D7 \varnothing f8	D8	D9	L5	L6	L7	Tightening torque [Nm]	CRC ¹⁾	Weight [g]	Part No.	Type
[mm]														
10	21	M3	3.4	11	30	12	22	3	1.6	0.7	2	10	32798	FWSR-10
12	25	M3	3.4	14	35	15	25	3	3	1.2	2	19	14659	FWSR-12
16	28	M4	4.5	16	40	17	28	5	3	1.2	2	30	13239	FWSR-16
25	35	M5	5.5	20	50	23	38	8	3	5.5	2	70	13240	FWSR-25
32	45	M6	6.6	28	60	28	48	10	4	5.5	2	120	13241	FWSR-32
40	54	M8	9	36	70	38	60	11	5	5.5	2	240	14656	FWSR-40

1) Corrosion resistance class CRC 2 to Festo standard FN 940070

Moderate corrosion stress. Indoor applications in which condensation may occur. External visible parts with primarily decorative requirements for the surface and which are in direct contact with the ambient atmosphere typical for industrial applications.

Semi-rotary drives DSR/DSRL

Accessories

FESTO

Freewheel unit FLSR

Material:

Housing: Aluminium die-cast

Sleeve, shaft: Case-hardened steel

Seal, cap: Nitrile rubber

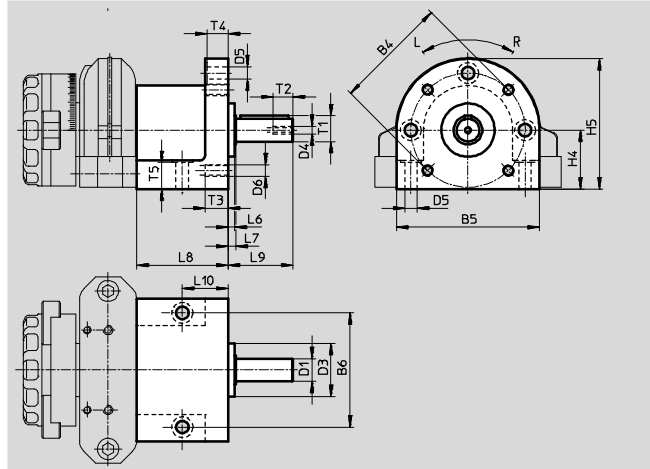

General technical data							
Piston \varnothing		10	12	16	25	32	40
Design	Freewheel unit as attachment						
Rotation angle	Infinitely adjustable steps (independent of rotation angle)						
Applied radial load	[N]	52	77	160	350	200	350
Applied axial load	[N]	30	50	100	200	75	120
Max. torque	[Nm]	0.7	1.3	2.7	6.6	13.3	26.7
Frequency	3 Hz ($\frac{1}{3}$ · The load must be stopped externally!)						
Temperature range	[°C]	-10 ... +60					

Direction of rotation

The freewheel unit blocks one of the two possible swivel directions of the DSM swivel module.

FLSM-...-R, right-hand (clockwise) rotation

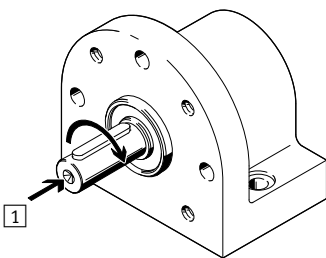

1 Viewed towards drive shaft

FLSM-...-L, left-hand (counter-clockwise) rotation

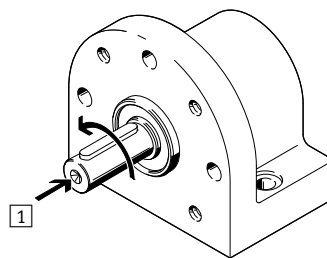

Semi-rotary drives DSR/DSRL

Accessories

Dimensions and ordering data															
For Ø [mm]	B4	B5	B6	D1 Ø g7	D3 Ø h8	D4	D5 Ø H13	D6	H4	H5	L6	L7	L8	L9	L10
10	38	45	38.5	6	20	–	3.3	M3	20	42.5	3.5	4.2	41.5	20.2	23
12	42	49	41.5	8	25	M3	3.3	M3	24	48.5	3.5	4.5	47.3	24.5	25
16	50	60	50	10	24	M3	4.5	M4	28	58	3.5	4.4	47	27.4	23.5
25	60	75	60	12	28	M4	6.6	M6	31	68.5	3.5	4.1	48	34	24
32	83	98	83	16	42	M5	6.6	M6	44	93	7.2	8.5	60	48.5	30
40	96	114	96	20	52	M6	8.6	M8	54	111	6	8	75	58	38

For Ø [mm]	T1	T2	T3	T4	T5	Woodruff key ¹⁾ to DIN 6885	CRC ²⁾	Weight [g]	Direction of rotation	Part No.	Type
10	6.8	8	8	5	8	A2 x 2 x 12	2	165	left-hand	33298	FLSR-10-L
									right-hand	33299	FLSR-10-R
12	8.8	9	8	5	9	A2 x 2 x 16	2	225	left-hand	30930	FLSR-12-L
									right-hand	30929	FLSR-12-R
16	11.2	11	10	8	11	A3 x 3 x 18	2	340	left-hand	15281	FLSR-16-L
									right-hand	15280	FLSR-16-R
25	13.5	14	12	11	14	A4 x 4 x 25	2	500	left-hand	13778	FLSR-25-L
									right-hand	13730	FLSR-25-R
32	18	16	12	11	16	A5 x 5 x 36	2	1 140	left-hand	15688	FLSR-32-L
									right-hand	15687	FLSR-32-R
40	22.5	21	15	11	21	A6 x 6 x 45	2	1 800	left-hand	19037	FLSR-40-L
									right-hand	19036	FLSR-40-R

1) included in scope of delivery

2) Corrosion resistance class CRC 2 to Festo standard FN 940070

Moderate corrosion stress. Indoor applications in which condensation may occur. External visible parts with primarily decorative requirements for the surface and which are in direct contact with the ambient atmosphere typical for industrial applications.

Semi-rotary drives DSR/DSRL



Accessories

Mounting kit

WSR-10/12-K

for micro switch S-3-BE, S-3-BE-SW

Material:

Steel

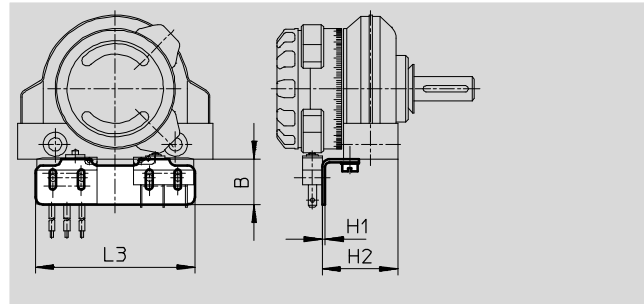

Dimensions and ordering data

For Ø	B	H1	H2	L3	CRC ¹⁾	Weight	Part No.	Type
[mm]						[g]		
10	15	1	22.2	47	2	11	33414	WSR-10-K
12	15	1	25.1	53	2	13	15686	WSR-12-K

1) Corrosion resistance class CRC 2 to Festo standard FN 940070

Moderate corrosion stress. Indoor applications in which condensation may occur. External visible parts with primarily decorative requirements for the surface and which are in direct contact with the ambient atmosphere typical for industrial applications.

Mounting kit

WSR-12 ... 40

for micro switch S-3-E and micro stem actuated valve S-3-PK-3-B, SO-3-PK-3-B

Material:

Steel

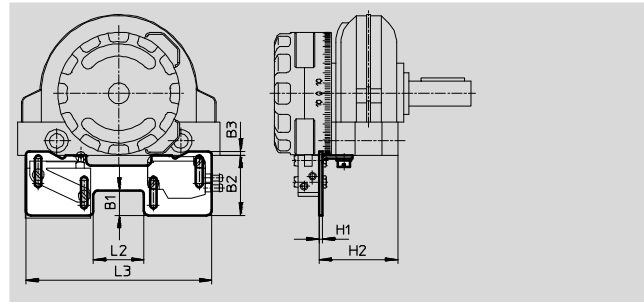
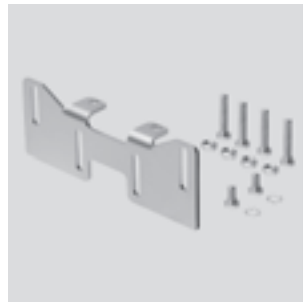

Dimensions and ordering data

For Ø	B1	B2	B3	H1	H2	L2	L3	CRC ¹⁾	Weight	Part No.	Type
[mm]									[g]		
12	5.8	23.4	4	1.5	23	14	79	2	12	15684	WSR-12
16	10	26.5	4.5	1.5	29.8	19	84.5	2	23	14874	WSR-16
25	12	29	2	1.5	38	24.5	90	2	26	14796	WSR-25
32	12	29	2	1.5	49.2	40.5	107	2	29	14960	WSR-32
40	12	29	2	1.5	68.7	52	118.5	2	32	14961	WSR-40

1) Corrosion resistance class CRC 2 to Festo standard FN 940070

Moderate corrosion stress. Indoor applications in which condensation may occur. External visible parts with primarily decorative requirements for the surface and which are in direct contact with the ambient atmosphere typical for industrial applications.

Semi-rotary drives DSR/DSRL

Accessories

Mounting kit

WSR-...-J

for proximity sensors SIEN-M8

WSR-...-J-M5

for proximity sensors SIEN-M5

Material:

Steel

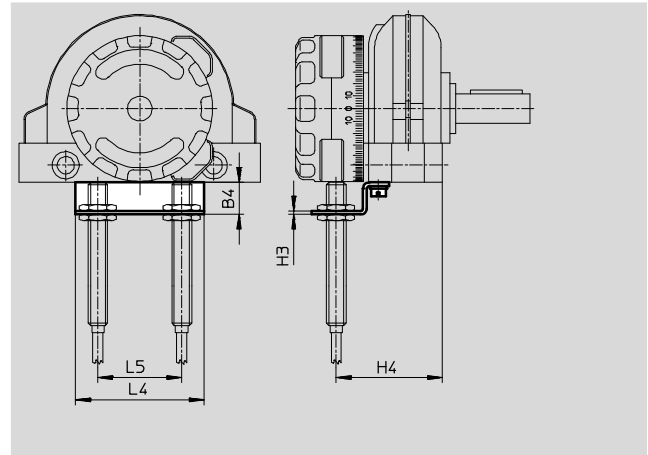

Dimensions and ordering data									
WSR-...-J									
For Ø	B4	H3	H4	L4	L5	CRC ¹⁾	Weight	Part No.	Type
[mm]							[g]		
16	13	1.5	35	52	27	2	12	14873	WSR-16-J
25	13	1.5	43.1	52	34	2	17	14799	WSR-25-J
32	13	1.5	54.3	64	48	2	18	14962	WSR-32-J
40	13	1.5	76.3	80	60	2	24	14963	WSR-40-J

WSR-...-J-M5									
For Ø	B4	H3	H4	L4	L5	CRC ¹⁾	Weight	Part No.	Type
[mm]							[g]		
10	8	1	25.4	30	20	2	6	33413	WSR-10-J-M5
12	8	1	28.3	34	24.5	2	10	15685	WSR-12-J-M5
16	8	1	34.9	38	27	2	78	15931	WSR-16-J-M5
25	13	1.5	43	52	34	2	17	15932	WSR-25-J-M5
32	13	1.5	54.3	64	48	2	25	15933	WSR-32-J-M5
40	13	1.5	76.3	80	60	2	30	15934	WSR-40-J-M5

1) Corrosion resistance class CRC 2 to Festo standard FN 940070
 Moderate corrosion stress. Indoor applications in which condensation may occur. External visible parts with primarily decorative requirements for the surface and which are in direct contact with the ambient atmosphere typical for industrial applications.

Semi-rotary drives DSR/DSRL

Accessories

FESTO

Electrical limit switch for end-position sensing

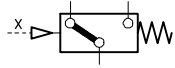

The switching point may only be exceeded by 0.5 mm in these electrical limit switches. Actuation only vertical to stem axis.

	S-3-BE	S-3-BE-SW	S-3-E
Connection	3 push-in connectors (2.8x0.5 mm)	3 wires (0.75 mm ²)	Screw connector
Contact rating	→ Table below		
Operating voltage	250 V AC/250 V DC		
Line current ohmic load	–	–	6 A/250 V AC 0.25 A/250 V DC
Line current inductive load	–	–	2 A/250 V AC 0.1 A/250 V DC
Utilisation category	AC 12/DC 12 (ohmic load) AC 14/DC 13 (inductive load)		
CE symbol	Yes, as per EU Directive 73/23/EEC		
Protection class to EN 60 529	IP40	IP67	IP00
Temperature range	–20 ... +85 °C		–20 ... +80 °C
Material	Housing, cover: black plastic		
Weight	2 g	16 g	7 g

Test symbols:

- S-3-BE: VDE-ÜG, UL, CSA, SEMKO
- S-3-BE-SW: VDE, SEV, SEMKO, BEAB
- S-3-E: VDE, ÖVE, SEMKO, SEV, UL, CSA

Contact configuration:

Changeover switch

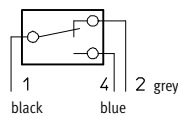

NC contact

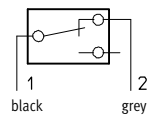

NO contact

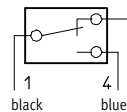

S-3-BE, S-3-BE-SW

AC voltage				
Voltage [V] ~	Resistance load [A]	Inductive load [A]		
12	6	6		
24	3	2		
60	1	0.5		
110	0.5	0.2		
220	0.25	0.1		
S-3-E	DC	AC	DC	AC
12	6	–	6	–
24	6	–	6	–
60	1	–	0.5	–
110	0.5	–	0.2	–
220	0.25	–	0.1	–
250	–	6	–	2

Pneumatic limit valve for end-position sensing

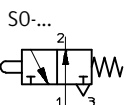
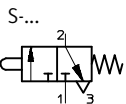

The switching point is pressure-dependent and deviates up to 0.8 mm in the pressure range from 0 ... 8 bar. The switching point may only be exceeded by 0.5 mm. The valve must not be used as a fixed stop and should only be operated vertically to the stem.

S-3-PK-3-B/SO-3-PK-3-B

Connection	Barbed fitting for 3 mm plastic tubing
Nominal size	1.8 mm
Standard nominal flow rate (1 > 2)	60 l/min
Pressure range	–0.95 ... +8 bar
Actuating force at 6 bar	6 N
Temperature range	–10 ... +60 °C
Materials	Plastic, brass
Weight	7 g

Semi-rotary drives DSR/DSRL

Accessories

Electrical limit switch for end-position sensing

Micro switch
S-3-BE

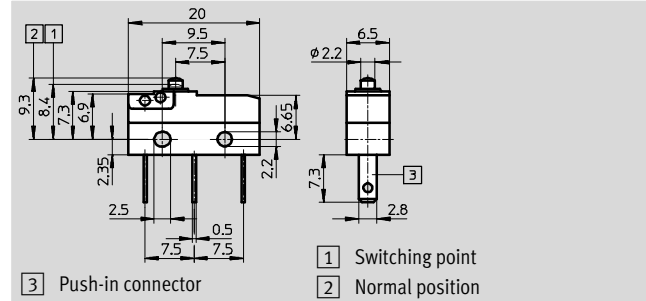
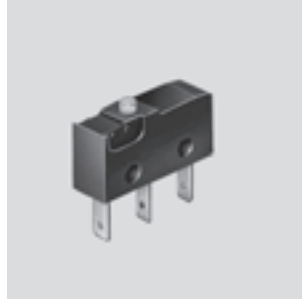

Micro switch with cable (splash-proof)
S-3-BE-SW

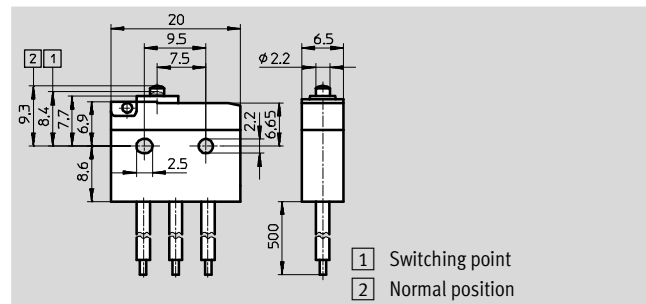

Micro switch
S-3-E

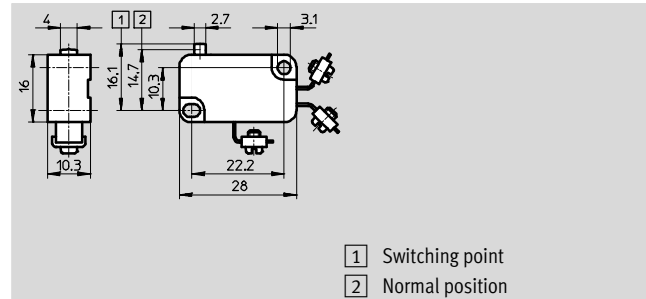

Micro switch with roller lever
(splash-proof)
SR-3-E-SW

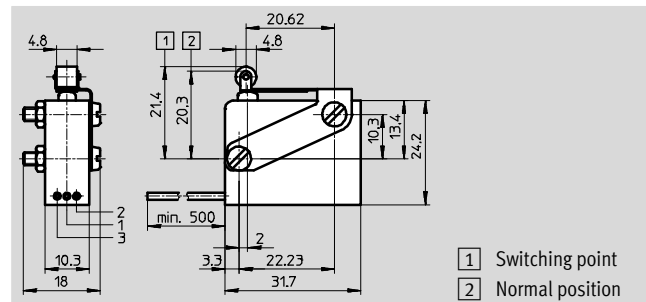

Ordering data

For Ø [mm]	Electrical limit switches, splash-proof	Design	Part No.	Type
10 ... 12			30 648	S-3-BE
		With cable	30 649	S-3-BE-SW
16 ... 40		With roller lever	7 347	S-3-E
			14 797	SR-3-E-SW

Semi-rotary drives DSR/DSRL

Accessories

FESTO

Pneumatic limit valve for end-position sensing

Micro stem actuated valve

S-3-PK-3-B

SO-3-PK-3-B

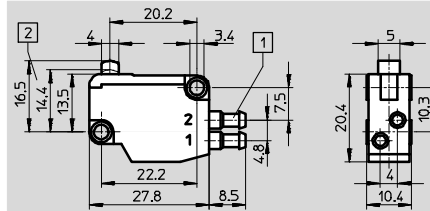
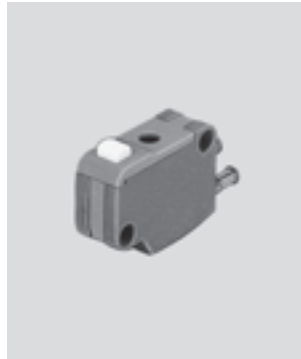

- 1 Barbed fittings for 3 mm plastic tubing
- 2 Switching point min.
- 1 (P) = supply port
- 2 (A) = working or outlet line
- 3 (R) = exhaust

Ordering data				
For Ø	Pneumatic limit switch	Design	Part No.	Type
[mm]				
16 ... 40		Normally closed	7 843	S-3-PK-3-B
		Normally open	10 403	SO-3-PK-3-B

Ordering data – Proximity sensors, inductive				Technical data → Internet: sien	
	For Ø	Remarks	Connection	Part No.	Type
	10 ... 40	For mounting kit WSR-...-J-M5	Cable	150 370	SIEN-M5B-PS-K-L
			Plug	150 371	SIEN-M5B-PS-S-L
	16 ... 40	For mounting kit WRM-...-J	Cable	150 386	SIEN-M8B-PS-K-L
			Plug	150 387	SIEN-M8B-PS-S-L

Ordering data – Connecting cables				Technical data → Internet: nebu	
	Electrical connection, left	Electrical connection, right	Cable length [m]	Part No.	Type
	Straight socket, M8x1, 3-pin	Cable, open end, 3-wire	2.5	541 333	NEBU-M8G3-K-2.5-LE3
			5	541 334	NEBU-M8G3-K-5-LE3
	Angled socket, M8x1, 3-pin	Cable, open end, 3-wire	2.5	541 338	NEBU-M8W3-K-2.5-LE3
			5	541 341	NEBU-M8W3-K-5-LE3

Ordering data – One-way flow control valves				Technical data → Internet: grla		
	Connection		Material	Part No.	Type	
	Thread	For tubing OD				
	M3	3	Metal design	175 041	GRLA-M3-QS-3	
		M5		3	193 137	GRLA-M5-QS-3-D
	4			193 138	GRLA-M5-QS-4-D	
	6			193 139	GRLA-M5-QS-6-D	
	G1/8			3	193 142	GRLA-1/8-QS-3-D
		4		193 143	GRLA-1/8-QS-4-D	
		6		193 144	GRLA-1/8-QS-6-D	
		8		193 145	GRLA-1/8-QS-8-D	
	G1/4	6		193 146	GRLA-1/4-QS-6-D	
		8		193 147	GRLA-1/4-QS-8-D	
		10			193 148	GRLA-1/4-QS-10-D

Product Range and Company Overview

A Complete Suite and Company Overview

Our experienced engineers provide complete support at every stage of your development process, including: conceptualization, analysis, engineering, design, assembly, documentation, validation, and production.



Custom Automation Components
Complete custom engineered solutions



Custom Control Cabinets
Comprehensive engineering support and on-site services



Complete Systems
Shipment, stocking and storage services

The Broadest Range of Automation Components

With a comprehensive line of more than 30,000 automation components, Festo is capable of solving the most complex automation requirements.



Electromechanical
Electromechanical actuators, motors, controllers & drivers



Pneumatics
Pneumatic linear and rotary actuators, valves, and air supply



PLCs and I/O Devices
PLC's, operator interfaces, sensors and I/O devices

Supporting Advanced Automation... As No One Else Can!

Festo is a leading global manufacturer of pneumatic and electromechanical systems, components and controls for industrial automation, with more than 16,000 employees in 60 national headquarters serving more than 180 countries. For more than 80 years, Festo has continuously elevated the state of manufacturing with innovations and optimized motion control solutions that deliver higher performing, more profitable automated manufacturing and processing equipment. Our dedication to the advancement of automation extends beyond technology to the education and development of current and future automation and robotics designers with simulation tools, teaching programs, and on-site services.

Quality Assurance, ISO 9001 and ISO 14001 Certifications

Festo Corporation is committed to supply all Festo products and services that will meet or exceed our customers' requirements in product quality, delivery, customer service and satisfaction.

To meet this commitment, we strive to ensure a consistent, integrated, and systematic approach to management that will meet or exceed the requirements of the ISO 9001 standard for Quality Management and the ISO 14001 standard for Environmental Management.



© Copyright 2013, Festo Corporation. While every effort is made to ensure that all dimensions and specifications are correct, Festo cannot guarantee that publications are completely free of any error, in particular typing or printing errors. Accordingly, Festo cannot be held responsible for the same. For Liability and Warranty conditions, refer to our "Terms and Conditions of Sale", available from your local Festo office. All rights reserved. No part of this publication may be reproduced, distributed, or transmitted in any form or by any means, electronic, mechanical, photocopying or otherwise, without the prior written permission of Festo. All technical data subject to change according to technical update.



Printed on recycled paper at New Horizon Graphic, Inc., FSC certified as an environmental friendly printing plant.

Festo North America

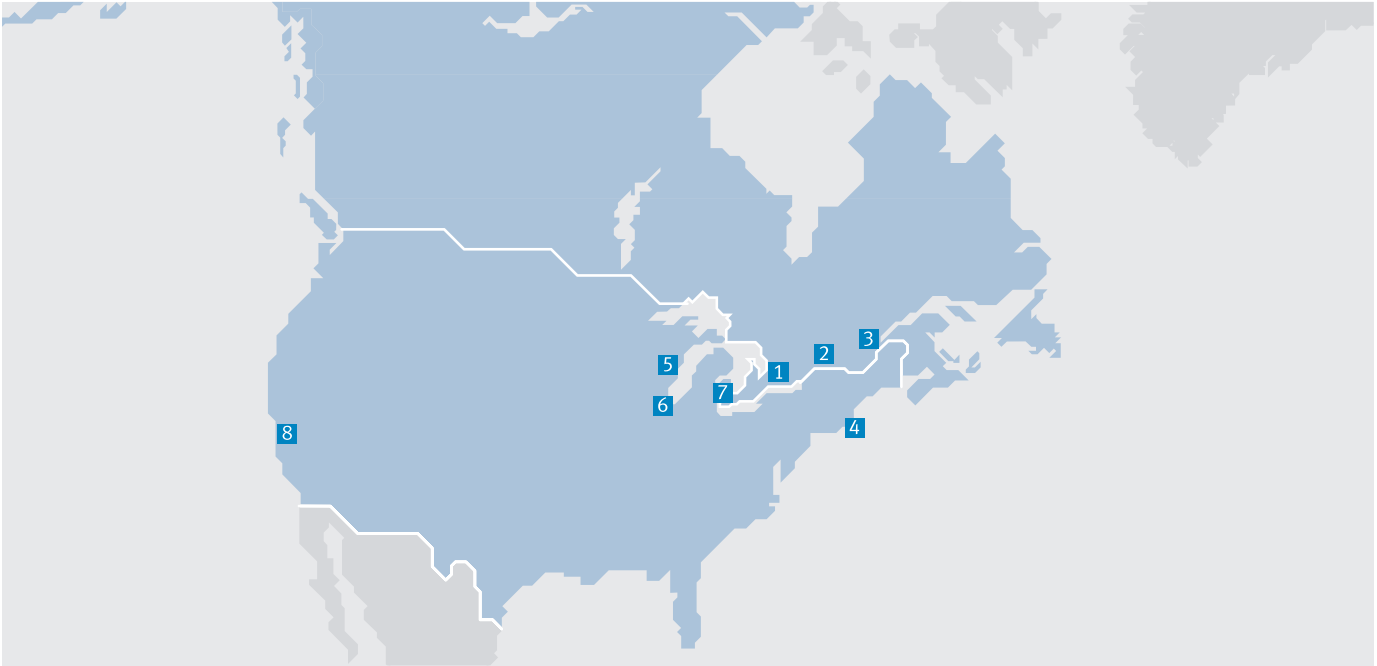

**1 Festo Canada
Headquarters
Festo Inc.**
5300 Explorer Drive
Mississauga, ON
L4W 5G4

2 Montréal
5600, Trans-Canada
Pointe-Claire, QC
H9R 1B6

3 Québec City
2930, rue Watt#117
Québec, QC
G1X 4G3



**4 Festo United States
Headquarters
Festo Corporation**
395 Moreland Road
Hauppauge, NY
11788

5 Appleton
North 922 Tower View Drive, Suite N
Greenville, WI
54942

7 Detroit
1441 West Long Lake Road
Troy, MI
48098

6 Chicago
85 W Algonquin - Suite 340
Arlington Heights, IL
60005

8 Silicon Valley
4935 Southfront Road, Suite F
Livermore, CA
94550

Festo Regional Contact Center

Canadian Customers

Commercial Support:
Tel: 1 877 GO FESTO (1 877 463 3786)
Fax: 1 877 FX FESTO (1 877 393 3786)
Email: festo.canada@ca.festo.com

Technical Support:

Tel: 1 866 GO FESTO (1 866 463 3786)
Fax: 1 877 FX FESTO (1 877 393 3786)
Email: technical.support@ca.festo.com

USA Customers

Commercial Support:
Tel: 1 800 99 FESTO (1 800 993 3786)
Fax: 1 800 96 FESTO (1 800 963 3786)
Email: customer.service@us.festo.com

Technical Support:

Tel: 1 866 GO FESTO (1 866 463 3786)
Fax: 1 800 96 FESTO (1 800 963 3786)
Email: product.support@us.festo.com