















Swivel modules DSMI-B, with integrated angular displacement encoder



Cylinders with displacement encoder

Product range overview

Function	Type	Description
Drives	Rodless	
	DDLI 	<ul style="list-style-type: none"> • Without guide • With contactless measuring displacement encoder • Based on linear drive DGC-K • Supply ports on end face • System product for handling and assembly technology
	DDCI 	<ul style="list-style-type: none"> • With guide • With contactless measuring displacement encoder • Based on linear drive DGC • Supply ports optionally on end face or front • System product for handling and assembly technology
	With piston rod	
	DNCI 	<ul style="list-style-type: none"> • With contactless measuring displacement encoder • Various piston rod variants • Standards-based cylinder to ISO 15552 <p>    </p>
	DDPC 	<ul style="list-style-type: none"> • With contactless measuring displacement encoder • Various piston rod variants • Standards-based cylinder to ISO 15552 <p>    </p>
DNC/DSBC 	<ul style="list-style-type: none"> • With attached potentiometer MLO-LWG • Various piston rod variants • Standards-based cylinder to ISO 15552 <p>    </p>	
Swivel modules	Swivel modules	
	DSMI 	<ul style="list-style-type: none"> • Based on swivel modules DSM • Integrated rotary potentiometer • Compact design • Wide range of mounting options

Cylinders with displacement encoder

Product range overview



Piston Ø	Stroke/swivel angle [mm/°]	Suitable				
		for positioning with		for end-position controller		for use as a measuring cylinder
		CPX-CMAX	CPX-CMPX	SPC11		
Rodless						
25, 32, 40, 63	100, 160, 225, 300, 360, 450, 500, 600, 750, 850, 1000, 1250, 1500, 1750, 2000	■	■	■	■	
18, 25, 32, 40, 63	100, 160, 225, 300, 360, 450, 500, 600, 750, 850, 1000, 1250, 1500, 1750, 2000	■	■	■	■	
With piston rod						
32, 40, 50, 63	10 ... 2000	-	-	-	■	
	100 ... 750	■	■	■	-	
80, 100	10 ... 2000	-	-	-	■	
	100 ... 750	■	■	■	-	
32, 40, 50, 63, 80	100, 150, 225, 300, 360, 450, 600, 750	■	■	■	■	
Swivel modules						
25, 40, 63	270	■	■	■	■	

Cylinders with displacement encoder

Features

Servopneumatic drive technology

Positioning and Soft Stop applications as an integral component of the valve terminal CPX – the modular peripheral system for decentralised automation tasks.

The modular design means that valves, digital inputs and outputs, positioning modules and end-position controllers, as appropriate to the application, can be combined in almost any way on the CPX terminal.

Advantages:

- Pneumatics and electrics – control and positioning on one platform
- Innovative positioning technology – piston rod drives, rodless drives, rotary drives
- Actuation via fieldbus
- Remote maintenance, remote diagnostics, web server, SMS and e-mail alerts are all possible via TCP/IP
- Modules can be quickly exchanged and expanded without altering the wiring

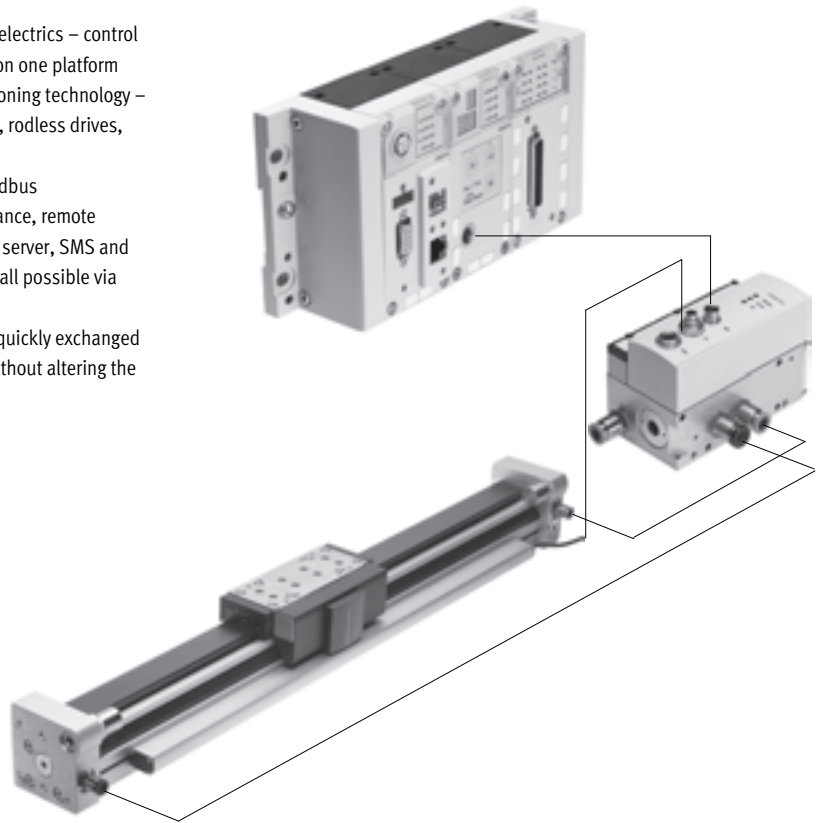

Axis controller CPX-CMAX



Free choice:

Position and force control, directly actuated or selected from one of 64 configurable position sets. If you are looking for something more: the configurable function for switching to the next set enables simple functional sequences to be realised with the axis controller CPX-CMAX.

All stations are recognised as: the auto-identification function identifies each participant with its device data on the controller CPX-CMAX.

Also included:

The functional scope of the controller CPX-CMAX includes actuation of a brake or clamping unit via the proportional directional control valve VPWP.

Up to 8 modules (max. 8 axes) can be operated in parallel and independently of each other. Commissioning via FCT (Festo configuration software) or via fieldbus: no programming, only configuration.

Technical data → Internet: cpx-cmax

Advantages:

- Greater flexibility
- OEM friendly – commissioning also via fieldbus
- Easy installation and fast commissioning
- Cost-effective
- You program the system in your PLC environment

Cylinders with displacement encoder

Features

FESTO

End-position controller CPX-CMPX



Fast travel between the mechanical end stops of the cylinder, stopping gently and without impact in the end position.
Fast commissioning via control panel, fieldbus or handheld unit. Improved control of downtime. Actuation of a brake or clamping unit via the proportional directional control valve VPWP is an integral part of the controller CMPX.

Depending on the fieldbus chosen, up to 9 end-position controllers can be actuated on the CPX terminal. All system data can be read and written via the fieldbus, including, for example, the mid positions.

Technical data → Internet: [cpx-cmpx](#)

- Advantages:
- Greater flexibility
 - OEM friendly – commissioning also via fieldbus
 - Easy installation and fast commissioning
 - Cost-effective
 - up to 30% faster cycle rates
 - significantly reduced system vibration
 - Improved work ergonomics thanks to significantly reduced noise level
 - The extended diagnostics help to reduce the service time of the machine

Proportional directional control valve VPWP



The 5/3-way proportional directional control valve for applications with Soft Stop and pneumatic positioning. Fully digitalised – with integrated pressure sensors, with new diagnostic functions. In sizes 4, 6, 8 and 10. Flow rate of 350, 700, 1400 and 2000 l/min.

With switching output for actuating a brake. Coloured supply ports. Pre-assembled cables guarantee faultless and fast connection with the controllers CPX-CMPX and CPX-CMAX.

Technical data → Internet: [vpwp](#)

- Advantages:
- Easy installation and fast commissioning
 - Reduction of system downtimes thanks to the new diagnostic options
 - With switching output for actuating a brake/clamping unit

Measuring module CPX-CMIX



Fully digital data acquisition and transmission means that pneumatic cylinders can be used as sensors. With very high repetition accuracy and incorporating both analogue and digital measuring sensors.

Suitable for the linear drive DGCI with displacement encoder for measuring absolute values, for the piston rod drive DNCI/DDPC with incremental displacement encoder or even for a potentiometer of the type MLO.

Technical data → Internet: [cpx-cmix](#)

- Advantages:
- All process steps can be documented, which improves quality
 - An adjustable contact force (via pressure regulator) increases the precision of the "displacement sensor"
 - With displacement encoders for measuring absolute values, the actual position is immediately available after the system is switched on

Cylinders with displacement encoder

Drive options

FESTO

System with linear drive DDLI, DGCI

Technical data → Internet: [ddli](#) or [dgci](#)

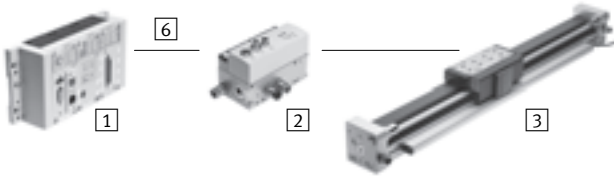

- 1 Controller module CPX-CMPX or CPX-CMAX
- 2 Proportional directional control valve VPWP
- 3 Linear drive DDLI, DGCI with displacement encoder
- 6 Connecting cable KVI-CP-3...

- Pneumatic rodless linear drive with displacement encoder, with or without recirculating ball bearing guide
- Displacement encoder with absolute and contactless measurement
- Diameters:
 - DGCI: 18 ... 63 mm
 - DDLI: 25 ... 63 mm
- Stroke: 100 ... 2000 mm in fixed lengths
- Range of applications: Soft Stop and pneumatic positioning
- Loads from 1 ... 180 kg
- No sensor interface required

Advantages:

- Complete drive unit
- DDLI for easy connection to customer's guide system
- Excellent running characteristics
- For fast and accurate positioning down to ± 0.2 mm (only with axis controller CPX-CMAX)

System with standard cylinder DNCI, DDPC

Technical data → Internet: [dncl](#)

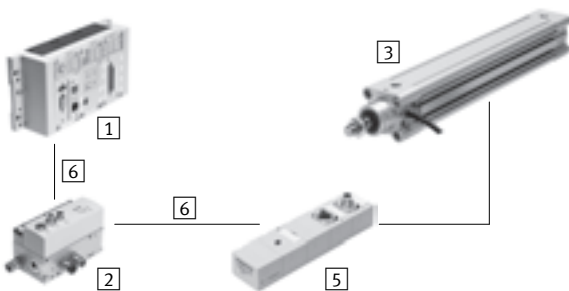

- 1 Controller module CPX-CMPX or CPX-CMAX
- 2 Proportional directional control valve VPWP
- 3 Standard cylinder DNCI, DDPC with displacement encoder
- 5 Sensor interface CASM-S-D3-R7
- 6 Connecting cable KVI-CP-3...

- Standard cylinder with integrated displacement encoder, conforms to DIN ISO 6432, VDMA 24 562, NF E 49 003.1 and Uni 10 290
- Displacement encoder with contactless and incremental measuring
- Diameter: 32 ... 100 mm
- Stroke: 100 ... 750 mm
- Range of applications: Soft Stop and pneumatic positioning
- Loads from 3 ... 450 kg and a matching sensor interface CASM-S-D3-R7
- Pre-assembled cables guarantee faultless and fast electrical connection

Advantages:

- Compact drive unit
- Can be used universally
- Also with guide unit
- For fast and accurate positioning up to ± 0.5 mm (only with axis controller CPX-CMAX)

Cylinders with displacement encoder

Drive options

System with swivel module DSMI

Technical data → Internet: [dsmi](#)

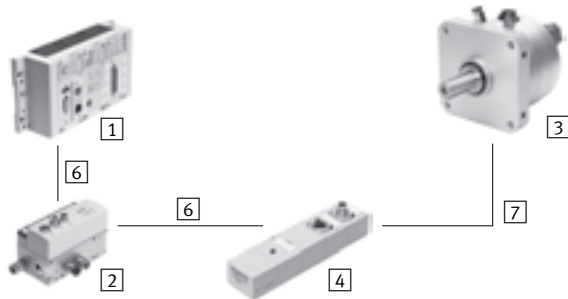

- 1 Controller module CPX-CMPX or CPX-CMAX
- 2 Proportional directional control valve VPWP
- 3 Swivel module DSMI with displacement encoder
- 4 Sensor interface CASM-S-D2-R3
- 6 Connecting cable KVI-CP-3-...
- 7 Connecting cable NEBC-P1W4-K-0,3-N-M12G5

- Swivel module DSMI with integrated displacement encoder
- Identical design to pneumatic swivel module DSM
- Absolute displacement encoder based on a potentiometer
- Swivel range of 0 ... 270°
- Size: 25, 40, 63
- Max. torque: 5 ... 40 Nm
- Range of applications: Soft Stop and pneumatic positioning
- Mass moments of inertia from 15 ... 6000 kgcm² and a matching sensor interface CASM-S-D2-R3
- Pre-assembled cables guarantee faultless and fast connection with the proportional directional control valve VPWP

- Advantages:
- Complete drive unit, compact, can be used immediately
 - High angular acceleration
 - With adjustable fixed stops
 - For fast and accurate positioning down to ±0.2° (only with axis controller CPX-CMAX)

System with potentiometer

Technical data → Internet: [casm](#)

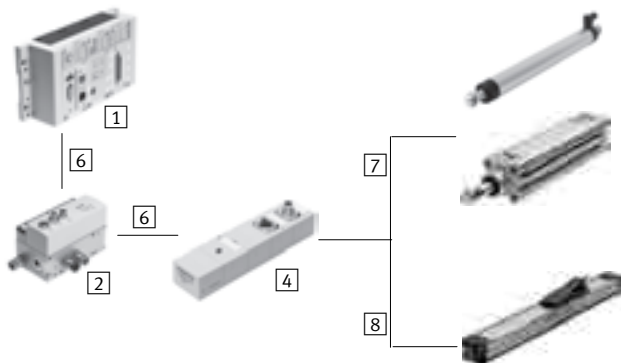

- 1 Controller module CPX-CMPX or CPX-CMAX
- 2 Proportional directional control valve VPWP
- 4 Sensor interface CASM-S-D2-R3
- 6 Connecting cable KVI-CP-3-...
- 7 Connecting cable NEBC-P1W4-K-0,3-N-M12G5
- 8 Connecting cable NEBC-A1W3-K-0,4-N-M12G5

- Attachable potentiometers with absolute measurement, with high degree of protection
- With connecting rod or moment compensator
- Measuring range:
Connecting rod: 100 ... 750 mm
Moment compensator: 225 ... 2000 mm
- Pre-assembled cables guarantee faultless and fast connection with the sensor interface CASM
- Range of applications: Soft Stop and pneumatic positioning with cylinder Ø 25 ... 80 mm, e.g. DNC or DSBC
- Loads from 1 ... 300 kg

- Advantages:
- Easy installation and fast commissioning
 - Cost-effective
 - Can also be used in harsh ambient conditions
 - Variety of drives: CPX-CMPX and CPX-CMAX also support cylinders with external displacement encoder

Cylinders with displacement encoder

Drive options

System components for Soft Stop systems with end-position controller CPX-CMPX						
	Linear drive	Standard cylinder	Swivel module	Displacement encoder		→ Page/ Internet
	DDLI/DGCI	DNCI, DDPC	DSMI	MLO-LWG/-TLF	MME-MTS	
End-position controller CPX-CMPX	■	■	■	■	■	cmpx
Prop. directional control valve VPWP	■	■	■	■	■	vpwp
Sensor interface CASM-S-D2-R3	-	-	■	■	-	casm
Sensor interface CASM-S-D3-R7	-	■	-	-	-	casm
Connecting cable KVI-CP-3-...	■	■	■	■	■	kvi
Connecting cable NEBC-P1W4-...	-	-	■	■ / -	-	nebc
Connecting cable NEBC-A1W3-...	-	-	-	- / ■	-	nebc
Connecting cable NEBP-M16W6-...	-	-	-	-	■	vpwp

System components for pneumatic positioning systems with axis controller CPX-CMAX						
	Linear drive	Standard cylinder	Swivel module	Displacement encoder		→ Page/ Internet
	DDLI/DGCI	DNCI, DDPC	DSMI	MLO-LWG/-TLF	MME-MTS	
Axis controller CPX-CMAX	■	■	■	■	■	cmax
Prop. directional control valve VPWP	■	■	■	■	■	vpwp
Sensor interface CASM-S-D2-R3	-	-	■	■	-	casm
Sensor interface CASM-S-D3-R7	-	■	-	-	-	casm
Connecting cable KVI-CP-3-...	■	■	■	■	■	kvi
Connecting cable NEBC-P1W4-...	-	-	■	■ / -	-	nebc
Connecting cable NEBC-A1W3-...	-	-	-	- / ■	-	nebc
Connecting cable NEBP-M16W6-...	-	-	-	-	■	vpwp

System components for measuring cylinders with measuring module CPX-CMIX						
	Linear drive	Standard cylinder	Swivel module	Displacement encoder		→ Page/ Internet
	DDLI/DGCI	DNCI, DDPC	DSMI	MLO-LWG/-TLF	MME-MTS	
Measuring module CPX-CMIX-M1-1	■	■	■	■	■	cmix
Sensor interface CASM-S-D2-R3	-	-	■	■	-	casm
Sensor interface CASM-S-D3-R7	-	■	-	-	-	casm
Connecting cable KVI-CP-3-...	(■) ¹⁾	■	■	■	(■)	kvi
Connecting cable NEBC-P1W4-...	-	-	■	■ / -	-	nebc
Connecting cable NEBC-A1W3-...	-	-	-	- / ■	-	nebc
Connecting cable NEBP-M16W6-...	-	-	-	-	■	vpwp

1) As an extension

Cylinders with displacement encoder

Overview

FESTO

Individual components for positioning With end-position controller SPC11

→ Internet: [spc11](#)



1

- 1 End-position controller SPC11-POT-LWG
- 2 Proportional directional control valve MPYE
- 3 Swivel module DSMI
- 4 Connecting cable KMPYE-AIF...



2



3

Individual components for use as a measuring cylinder With measuring module CPX-CMIX

→ Internet: [cmix](#)



1



2



3

- 1 Measuring module CPX-CMIX
- 2 Sensor interface CASM-S-D2-R3
- 3 Swivel module DSMI

Swivel modules DSMI-B, with integrated angular displacement encoder

Key features

FESTO

At a glance

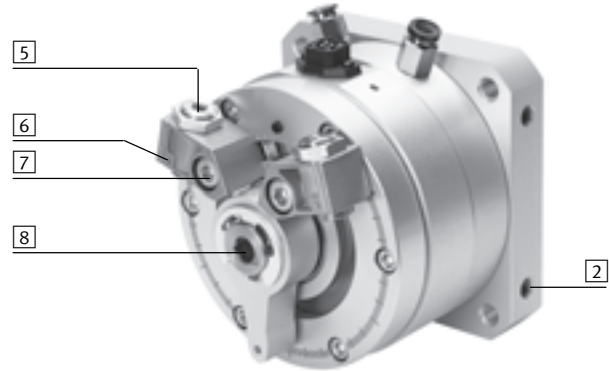
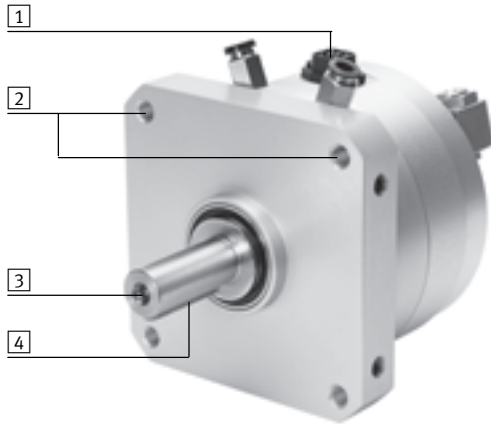

- | | | | |
|--|---|---|---|
| <ul style="list-style-type: none"> 1 Connector plug for displacement encoder 2 Wide range of integrated mounting options 3 Option for mounting on the drive shaft by the user | <ul style="list-style-type: none"> 4 Feather key 5 Fixed stop with precision adjustment of the swivel angle 6 Mounting facility for proximity sensors using sensor bracket, for contactless position sensing | <ul style="list-style-type: none"> 7 Fixed stop can be set at any point within the swivel angle 8 Manual operation via internal hexagon socket in the drive shaft | <p>A female thread is already integrated for attachment of an additional drive shaft by the user.</p> |
|--|---|---|---|

Mounting options

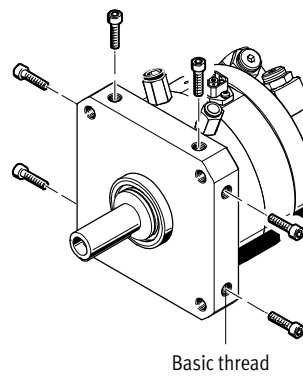
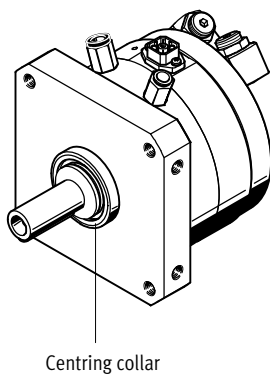
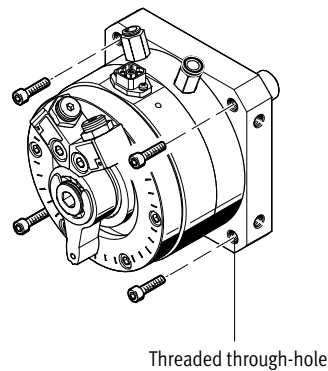
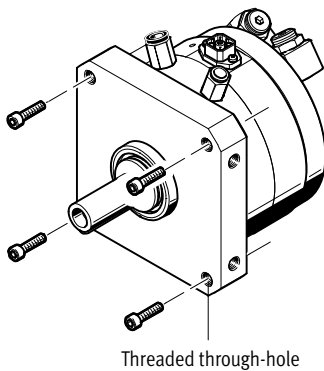

Swivel modules DSMI-B, with integrated angular displacement encoder

Peripherals overview

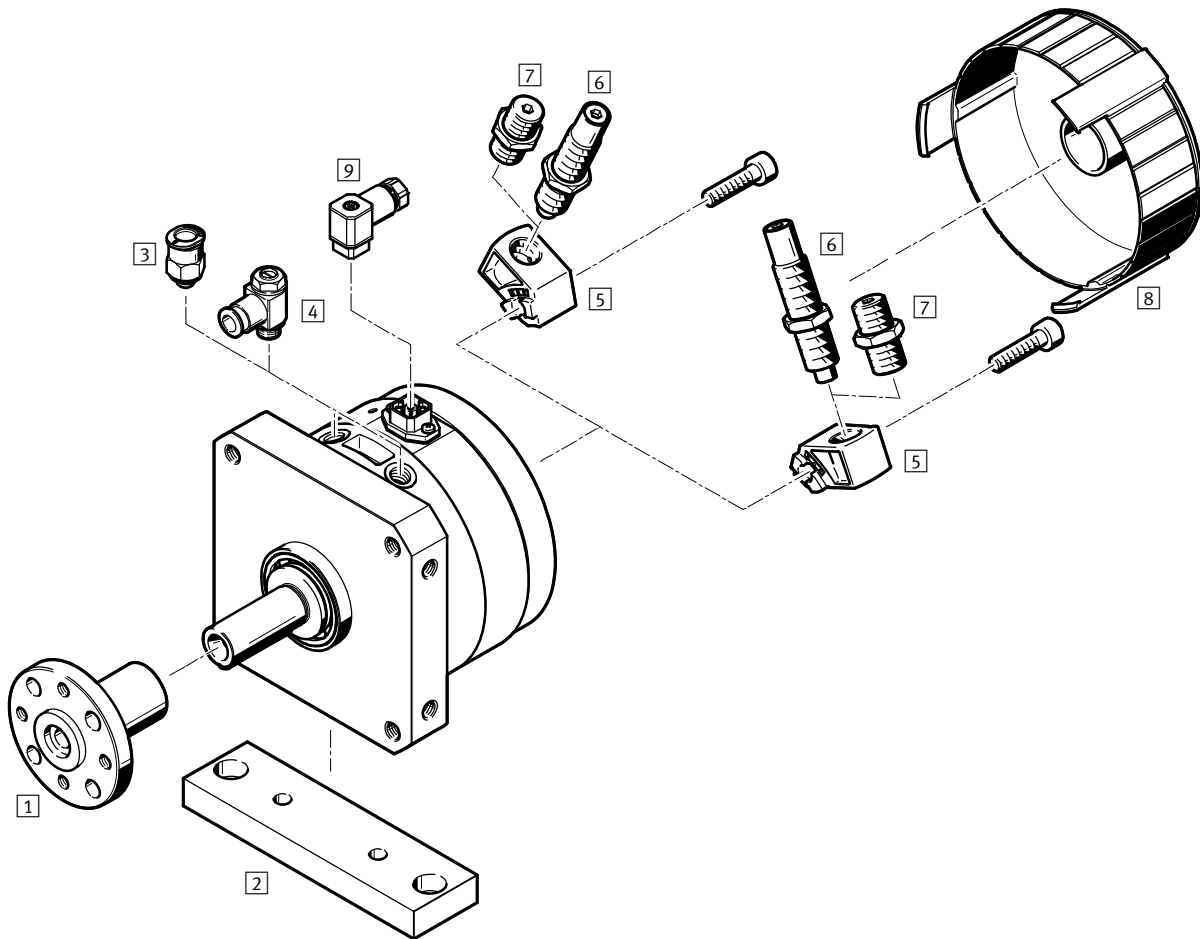

Accessories			
	For size	Description	→ Page/Internet
1	25, 40	Push-on flange FWSR For mounting attachments	18
2	25, 40	Mounting plate HSM Adapter plate for mounting the drive	18
3	25, 40, 63	Push-in fitting QS For connecting compressed air tubing with standard O.D. (push-in fittings are included in the scope of delivery of the drive)	quick star
4	25, 40, 63	One-way flow control valve GRLA For regulating speed (is recommended when using the DSMI as a measuring cylinder)	20
5	25, 40, 63	Cushioning mount DSM-B • For elastic cushioning components • For shock absorbers • As a mechanical stop in Soft Stop applications	19
6	25, 40, 63	Shock absorber DYSC Self-adjusting shock absorbers with fixed stop (is recommended when using the DSMI as a measuring cylinder)	19
7	25, 40, 63	Cushioning kit DSM...-P-B Elastic cushioning components with fixed stop	19
8	25, 40	Cover cap AKM Reduces the risk of injury in the swivel range of the stop lever	19
9	25, 40, 63	Plug socket SD For connecting the displacement encoder	20

Swivel modules DSMI-B, with integrated angular displacement encoder

Type codes

		DSMI	-		-	270	-	A	-	B
Type										
Double-acting										
DSMI	Swivel module with angular displacement encoder									
Size										
Max. swivel angle [°]										
Position sensing										
A	Via proximity sensor									
Variant										
B	B series									

Swivel modules DSMI-B, with integrated angular displacement encoder

Technical data

-  Size
25 ... 63
-  Torque
5 ... 40 Nm



General technical data			
Size	25	40	63
Design	Rotary vane Drive shaft, fitted with ball bearings		
Mode of operation	Double-acting		
Type of mounting	Via female thread		
Position sensing	Via integrated angular displacement encoder Via proximity sensor ¹⁾		
Measuring principle (angular displacement encoder)	Analogue with conductive plastic potentiometer		
Min. travel speed [°/s]	50		
Max. travel speed [°/s]	2000		
Max. swivel angle ²⁾ [°]	272		
Adjustment range of swivel angle [°]	0 ... 270		
Pneumatic connection	M5	G ¹ / ₈	G ¹ / ₄
Push-in fitting used	QSM-M5-6	QS-G ¹ / ₈ -8-I	QS-G ¹ / ₄ -8-I
Compressed air tubing O.D. [mm]	6	8	8

- 1) Not included in the scope of delivery, can be ordered as an option
- 2) Note stroke reduction in combination with axis controller CPX-CMAX

Operating and environmental conditions	
Operating pressure [bar]	2 ... 10
Operating pressure ¹⁾ [bar]	4 ... 8
Operating medium ²⁾	Compressed air according to ISO 8573-1:2010 [6:4:4]
Note about the operating/pilot medium	Lubricated operation not possible Pressure dew point 10 °C below ambient/medium temperature
Ambient temperature ³⁾ [°C]	-10 ... +60
Vibration resistance to DIN/IEC 68, Part 2 - 6	Severity level 2
Continuous shock resistance to DIN/IEC 68, Part 2 - 82	Severity level 2
CE marking (see declaration of conformity) ⁴⁾	To EU EMC Directive
Corrosion resistance class CRC ⁵⁾	1

- 1) Only applies to applications with end-position controller CPX-CMPX, SPC11 and axis controller CPX-CMAX
- 2) The proportional directional control valve VPWP, MPYE requires these characteristic values
- 3) Note operating range of proximity sensors
- 4) For information about the applicability of the component see the manufacturer's EC declaration of conformity at: www.festo.com/sp → User documentation.
If the component is subject to restrictions on usage in residential, office or commercial environments or small businesses, further measures to reduce the emitted interference may be necessary.
- 5) Corrosion resistance class CRC 1 to Festo standard FN 940070
Low corrosion stress. For dry indoor applications or transport and storage protection. Also applies to parts behind covers, in the non-visible interior area, and parts which are covered in the application (e.g. drive trunnions).

Weight			
Size	25	40	63
DSMI [g]	1080	3950	6900

Swivel modules DSMI-B, with integrated angular displacement encoder

Technical data

Torque [Nm]			
Size	25	40	63
Torque ¹⁾	5	20	40

1) Theoretical values, calculated at 6 bar

Permissible forces on the drive shaft			
Size	25	40	63
Max. radial force [N]	120	350	500
Max. axial force [N]	50	120	500
Max. swivel frequency ¹⁾ [Hz]	2		1

1) At max. permissible mass moment of inertia, operating pressure of 6 bar and a swivel angle of 270°

-  Note

More technical data

➔ Internet: dsm

Positioning characteristics with axis controller CPX-CMAX			
Size	25	40	63
Mounting position	Any		
Resolution [°]	0.1		
Repetition accuracy [°]	≤ ±0.3		
Min. mass moment of inertia, horizontal ¹⁾ [kgm ²]	15 x 10 ⁻⁴	60 x 10 ⁻⁴	300 x 10 ⁻⁴
Max. mass moment of inertia, horizontal ¹⁾ [kgm ²]	300 x 10 ⁻⁴	1200 x 10 ⁻⁴	6000 x 10 ⁻⁴
Min. mass moment of inertia, vertical ²⁾ [kgm ²]	15 x 10 ⁻⁴	60 x 10 ⁻⁴	300 x 10 ⁻⁴
Max. mass moment of inertia, vertical ²⁾ [kgm ²]	300 x 10 ⁻⁴	1200 x 10 ⁻⁴	6000 x 10 ⁻⁴
Min. travel speed [°/s]	50		
Max. travel speed [°/s]	2000		
Typical positioning time, long stroke ³⁾ [s]	0.35/0.60	0.30/0.55	0.64/1
Typical positioning time, short stroke ⁴⁾ [s]	0.15/0.25	0.25/0.25	0.30/0.35
Min. positioning stroke [°]	5		
Max. swivel stroke ⁵⁾ [°]	260		
Recommended proportional directional control valve			
For CPX-CMAX	VPWP-4-L-5-Q6-10-E-F	VPWP-4-L-5-Q8-10-E-F	

- 1) Must not change during the movement, but may be outside the centre of gravity
- 2) Must not change during the movement, must act at the centre of gravity
- 3) At 6 bar, vertical mounting position, 260° positioning angle at min./max. mass moment of inertia
- 4) At 6 bar, vertical mounting position, 15° positioning angle at min./max. mass moment of inertia
- 5) A stroke reduction of 5° on both sides must be observed

Swivel modules DSMI-B, with integrated angular displacement encoder

Technical data

Positioning characteristics with Soft Stop end-position controller CPX-CMPX, SPC11				
Size		25	40	63
Mounting position		Horizontal		
End-position repetition accuracy ¹⁾	[°]	< ±0.2		
Intermediate-position repetition accuracy	[°]	±2		
Cushioning ²⁾		Electronically controlled		
Min. mass moment of inertia, horizontal ³⁾	[kgm ²]	15 x 10 ⁻⁴	60 x 10 ⁻⁴	300 x 10 ⁻⁴
Max. mass moment of inertia, horizontal ³⁾	[kgm ²]	300 x 10 ⁻⁴	1200 x 10 ⁻⁴	6000 x 10 ⁻⁴
Min. swivel stroke	[°]	15		
Recommended proportional directional control valve				
For CPX-CMPX		VPWP-4-L-5-Q6-10-E-F	VPWP-4-L-5-Q8-10-E-F	
For SPC11		MPYE-5-M5-010-B	MPYE-5-1/8-LF-010-B	

- 1) When using the DSMI stops
- 2) The cushioning pad on the stop lever must be removed for applications with Soft Stop. The stop lever must not swivel to the end stop at too great a speed as this could damage the swivel module
- 3) Must not change during the movement, but may be outside the centre of gravity

Electrical data – Displacement encoder			
Output signal		Analogue	
Linearity error ¹⁾	[%]	< ±0.25	
Power supply ²⁾	[V DC]	10	
Max. current consumption	[mA]	4	
Wiper current	Recommended	[µA]	< 1
	Maximum ³⁾	[mA]	10
Connection resistance	[kΩ]	5	
Connection resistance tolerance	[%]	±20	
Protection class		IP65	
CE marking (see declaration of conformity)		To EU EMC Directive ⁴⁾	
Electrical connection		4-pin plug, □ 16, DIN 45 322	

- 1) Refers to max. swivel angle
- 2) Stabilised power supply is recommended, max. 42 V DC permissible
- 3) Only permissible in the short term in the event of a fault
- 4) For information about the applicability of the component see the manufacturer's EC declaration of conformity at: www.festo.com/sp → User documentation.
If the component is subject to restrictions on usage in residential, office or commercial environments or small businesses, further measures to reduce the emitted interference may be necessary.

Pin allocation of plug	
	
Pin	Function
1	24 V Power supply
2	Sig Signal
3	0 V GND
4	PE Screening

Swivel modules DSMI-B, with integrated angular displacement encoder

Technical data

Materials

Sectional view

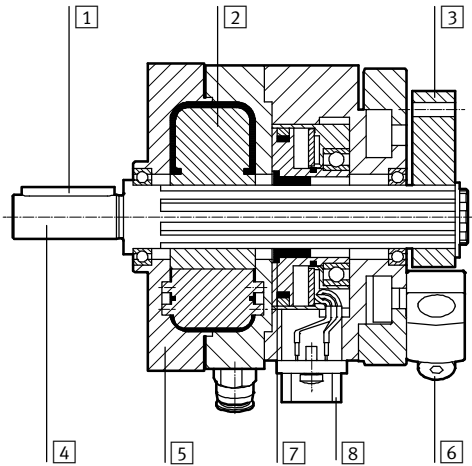

Cylinder/displacement encoder		
Cylinder		
1	Feather key	Steel
2	Rotary vane	Glass fibre-reinforced plastic
3	Stop lever	Anodised wrought aluminium alloy
4	Drive shaft	Nickel-plated steel
5	Housing	Anodised wrought aluminium alloy
6	Fixed stop/screw	Steel
	Note on materials	Free of copper and PTFE RoHS-compliant
Displacement encoder		
7	Coupling	Polyurethane
8	Housing	Anodised aluminium

Swivel modules DSMI-B, with integrated angular displacement encoder

Technical data

Dimensions

Download CAD data → www.festo.com

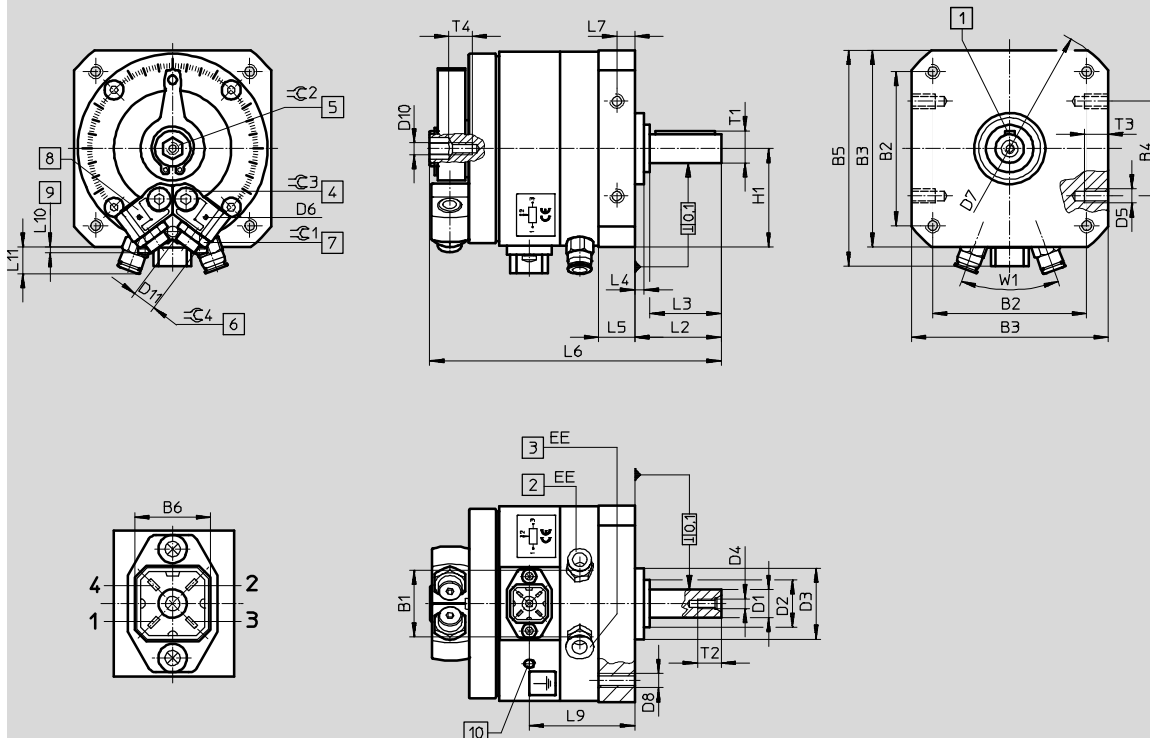

- 1 Feather key position at 0°
- 2 Blue release ring for supply port
- 3 Black release ring for supply port
- 4 Locking screw for clamping the stop
- 5 Manual override (internal hex)
- 6 End-position adjustment
- 7 Lock nut for end-position adjustment
- 8 Infinitely adjustable stops
- 9 Projection for end-position adjustment
- 10 Earth terminal for self-tapping M4x8 screw

Size	B1	B2	B3	B4	B5	B6	D1 g7 ∅	D2 ∅	D3 f8 ∅	D4	D5	D6	D7 ∅
25	±0.5	65±0.3	83±0.3	40±0.2	91	16	12	20 ^{-0.3}	30	M4	M6	M2	106±0.3
40		105±0.3	130±0.5	80±0.3	139	16	20	36 ^{-0.4}	52	M6	M10	M2	168±0.5
63		125±0.5	152±0.5	80±0.3	157	16	25	40±0.3	70	M10	M10	M3	200±0.5

Size	D8	D10	D11	EE	H1	L2	L3	L4	L5	L6	L7	L9	L10
					±0.2	+0.6/-0.7	±0.2	±0.4	+0.2/-0.3		±0.2	±1	
25	M6	M5	M10x1	M5	41.5	36.5	30	4	15.2	123±0.5	7.5	44.5	2.9
40	M10	M6	M16x1	G1/8	65	62	50	8	23.7	184±0.6	12	64.5	3.4
63	M12	M6	M22x1.5	G1/4	76	75.5	60	10.5	28.5	235±0.6	14	80.5	6

Size	L11	T1	T2	T3	T4	W1	∠1	∠2	∠3	∠4	Feather key to DIN 6885
	±2	max.	+2	±0.2							
25	12	13.5	10	10	10	40°	13	8	4	3	A4x4x25
40	16	22.5	16	15	10	40°	19	10	8	5	A6x6x45
63	20	28	22	16	20	40°	27	10	8	5	A8x7x50

Swivel modules DSMI-B, with integrated angular displacement encoder

Accessories

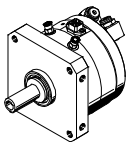
Ordering data		Size	Swivel angle [°]	Part No.	Type
		25	270	561690	DSMI-25-270-A-B
		40		561691	DSMI-40-270-A-B
		63		1202485	DSMI-63-270-A-B

Accessories

Push-on flange FWSR

Material:
Anodised aluminium
Free of copper and PTFE

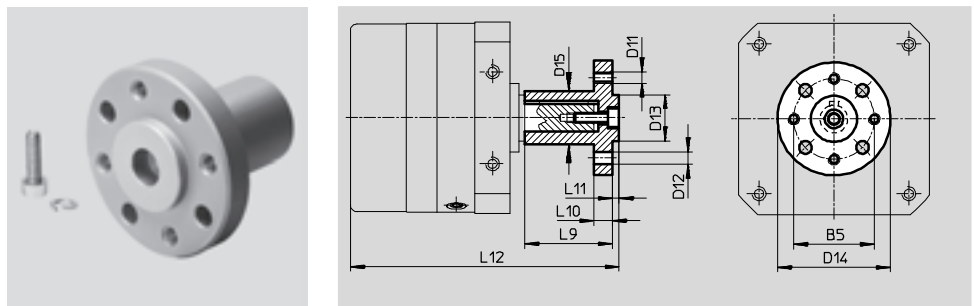

Dimensions and ordering data													
For size	B5	D11	D12	D13	D14	D15	L9	L10	L11	L12	Weight	Part No.	Type
[mm]			∅	∅	∅	∅					[g]		
25	35	M5	5.5	20	50	23	38	8	3	116.5	68	13240	FWSR-25
40	54	M8	9	36	70	38	60	11	5	186.5	240	14656	FWSR-40

Mounting plate HSM

Material:
Anodised aluminium
Free of copper and PTFE

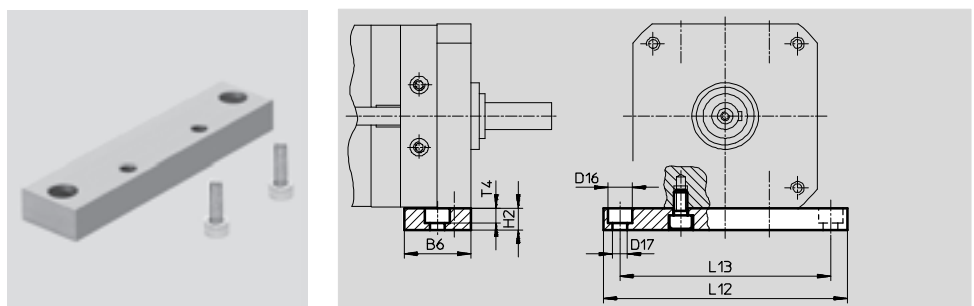

Dimensions and ordering data										
For size	B6	D16	D17	H2	L12	L13	T4	Weight	Part No.	Type
[mm]		∅	∅					[g]		
25	30	11	6.6	10	110	95	6.8	94	165573	HSM-25
40	45	18	11	20	180	155	11	459	165575	HSM-40

Swivel modules DSMI-B, with integrated angular displacement encoder

Accessories

Cover cap AKM

Material:
Polyamide

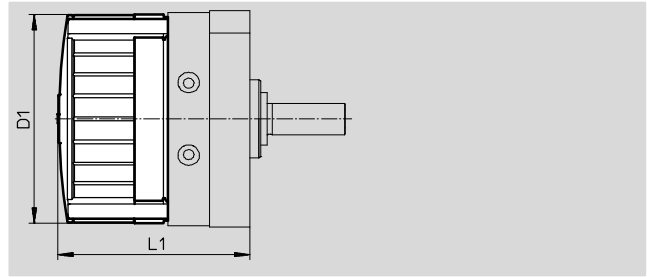
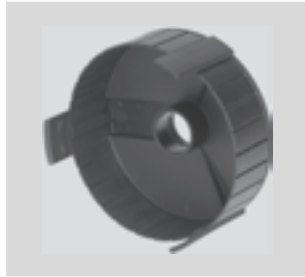

Dimensions and ordering data				
For size [mm]	D1	L1	Part No.	Type
25	83	98.5±1.2	549196	AKM-25
40	130	135.5±1.5	549198	AKM-40

Ordering data					
	For size	Brief description	Part No.	Type	PU ¹⁾
Cushioning mount					
	25	<ul style="list-style-type: none"> For elastic cushioning components For shock absorbers 	547902	DSM-25-B	2
	40		547904	DSM-40-B	
	63		552085	DSM-63-B	
Cushioning kit					
	25	For cushioning mount DSMI-...-B	550658	DSM-16/25-P-B	2
	40		550660	DSM-40-P-B	
	63		552086	DSM-63-P-B	
Shock absorber					
	25	For cushioning mount DSMI-...-B	548012	DYSC-7-5-Y1F	1
	40		548014	DYSC-12-12-Y1F	
	63		553593	DYSC-16-18-Y1F	

1) Packaging unit

Swivel modules DSMI-B, with integrated angular displacement encoder



Accessories

Ordering data – One-way flow control valves				Technical data → Internet: grla		
	For size	Connection		Material	Part No.	Type
		Thread	For tubing O.D.			
For exhaust air						
	25	M5	3	Metal design	193137	GRLA-M5-QS-3-D
			4		193138	GRLA-M5-QS-4-D
			6		193139	GRLA-M5-QS-6-D
	40	G1/8	3		193142	GRLA-1/8-QS-3-D
			4		193143	GRLA-1/8-QS-4-D
			6		193144	GRLA-1/8-QS-6-D
			8		193145	GRLA-1/8-QS-8-D
			10		193148	GRLA-1/8-QS-10-D
	63	G1/4	10			

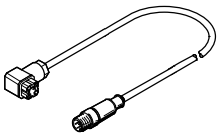
Ordering data – Connecting cable			
	Description	Part No.	Type
	Between sensor interface CASM and displacement encoder	549293	NEBC-P1W4-K-03-N-M12G5

Ordering data – Plug sockets			
	Description	Part No.	Type
	For displacement encoder connection	194332	SD-4-WD-7

Product Range and Company Overview

A Complete Suite and Company Overview

Our experienced engineers provide complete support at every stage of your development process, including: conceptualization, analysis, engineering, design, assembly, documentation, validation, and production.

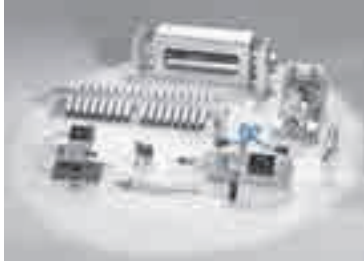

Custom Automation Components
Complete custom engineered solutions



Custom Control Cabinets
Comprehensive engineering support and on-site services

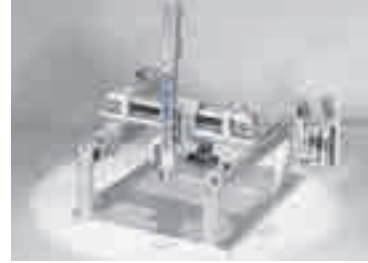

Complete Systems
Shipment, stocking and storage services

The Broadest Range of Automation Components

With a comprehensive line of more than 30,000 automation components, Festo is capable of solving the most complex automation requirements.



Electromechanical
Electromechanical actuators, motors, controllers & drivers



Pneumatics
Pneumatic linear and rotary actuators, valves, and air supply



PLCs and I/O Devices
PLC's, operator interfaces, sensors and I/O devices

Supporting Advanced Automation... As No One Else Can!

Festo is a leading global manufacturer of pneumatic and electromechanical systems, components and controls for industrial automation, with more than 16,000 employees in 60 national headquarters serving more than 180 countries. For more than 80 years, Festo has continuously elevated the state of manufacturing with innovations and optimized motion control solutions that deliver higher performing, more profitable automated manufacturing and processing equipment. Our dedication to the advancement of automation extends beyond technology to the education and development of current and future automation and robotics designers with simulation tools, teaching programs, and on-site services.

Quality Assurance, ISO 9001 and ISO 14001 Certifications

Festo Corporation is committed to supply all Festo products and services that will meet or exceed our customers' requirements in product quality, delivery, customer service and satisfaction.

To meet this commitment, we strive to ensure a consistent, integrated, and systematic approach to management that will meet or exceed the requirements of the ISO 9001 standard for Quality Management and the ISO 14001 standard for Environmental Management.



© Copyright 2013, Festo Corporation. While every effort is made to ensure that all dimensions and specifications are correct, Festo cannot guarantee that publications are completely free of any error, in particular typing or printing errors. Accordingly, Festo cannot be held responsible for the same. For Liability and Warranty conditions, refer to our "Terms and Conditions of Sale", available from your local Festo office. All rights reserved. No part of this publication may be reproduced, distributed, or transmitted in any form or by any means, electronic, mechanical, photocopying or otherwise, without the prior written permission of Festo. All technical data subject to change according to technical update.



Printed on recycled paper at New Horizon Graphic, Inc., FSC certified as an environmental friendly printing plant.

Festo North America

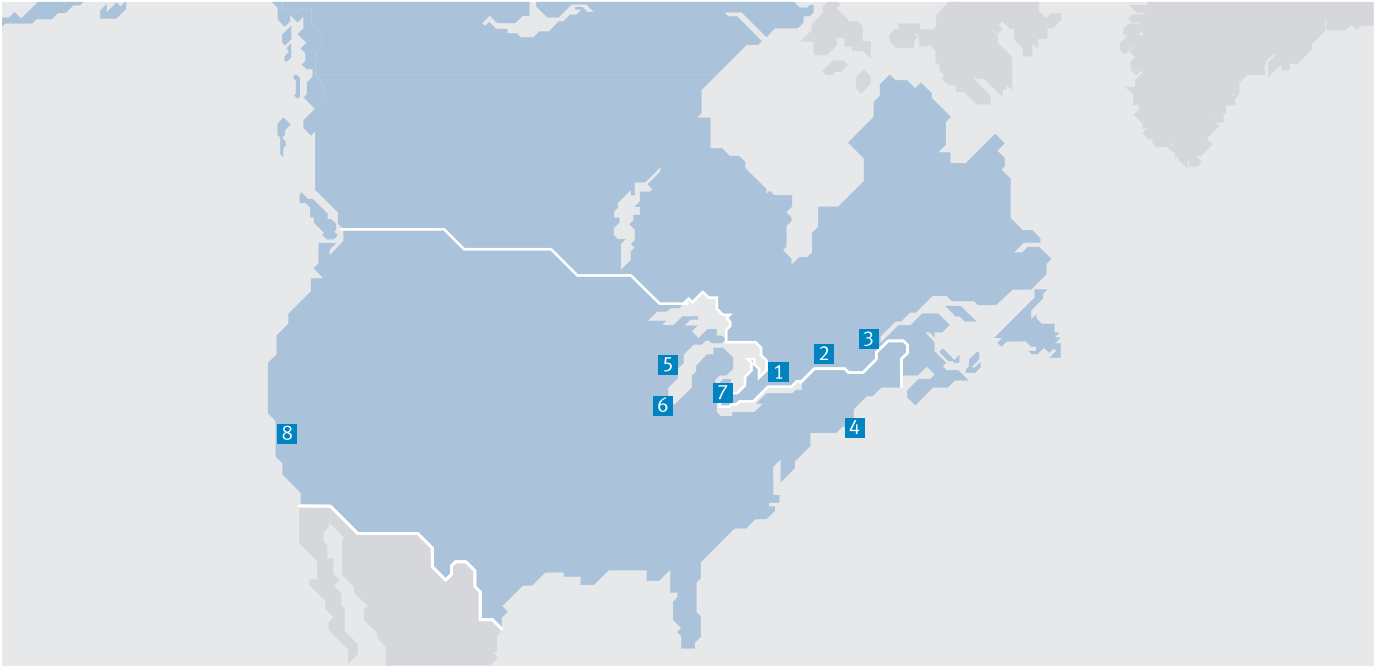

**1 Festo Canada
Headquarters
Festo Inc.**
5300 Explorer Drive
Mississauga, ON
L4W 5G4

2 Montréal
5600, Trans-Canada
Pointe-Claire, QC
H9R 1B6

3 Québec City
2930, rue Watt#117
Québec, QC
G1X 4G3



**4 Festo United States
Headquarters
Festo Corporation**
395 Moreland Road
Hauppauge, NY
11788

5 Appleton
North 922 Tower View Drive, Suite N
Greenville, WI
54942

7 Detroit
1441 West Long Lake Road
Troy, MI
48098

6 Chicago
85 W Algonquin - Suite 340
Arlington Heights, IL
60005

8 Silicon Valley
4935 Southfront Road, Suite F
Livermore, CA
94550

Festo Regional Contact Center

Canadian Customers

Commercial Support:
Tel: 1 877 GO FESTO (1 877 463 3786)
Fax: 1 877 FX FESTO (1 877 393 3786)
Email: festo.canada@ca.festo.com

Technical Support:
Tel: 1 866 GO FESTO (1 866 463 3786)
Fax: 1 877 FX FESTO (1 877 393 3786)
Email: technical.support@ca.festo.com

USA Customers

Commercial Support:
Tel: 1 800 99 FESTO (1 800 993 3786)
Fax: 1 800 96 FESTO (1 800 963 3786)
Email: customer.service@us.festo.com

Technical Support:
Tel: 1 866 GO FESTO (1 866 463 3786)
Fax: 1 800 96 FESTO (1 800 963 3786)
Email: product.support@us.festo.com