

Swivel/linear drive units DSL-B



Swivel/linear drive units DSL-B

Key features



At a glance

- High repetition accuracy thanks to cushioning components with fixed stop
- Swivel angle can be infinitely and accurately set
- The mechanical gearing between the stop element and swivel module prevents movement of the stop system under load
- Compact sensing of the swivel motion via proximity sensors SME/SMT-10F
- With plain-bearing guide
- With recirculating ball bearing guide
- Swivel motion of up to 270°
- Linear motion of up to 200 mm stroke
- Both motion types can be controlled individually or simultaneously
- High rotational energy during swivelling thanks to directly mounted, self-adjusting shock absorbers
- Supply ports at one end for quick, clear-cut tubing connections
- High precision thanks to recirculating ball bearing guide
 - Backlash-free swivel motion
 - Resists torque loads even during linear motion

The technology in detail

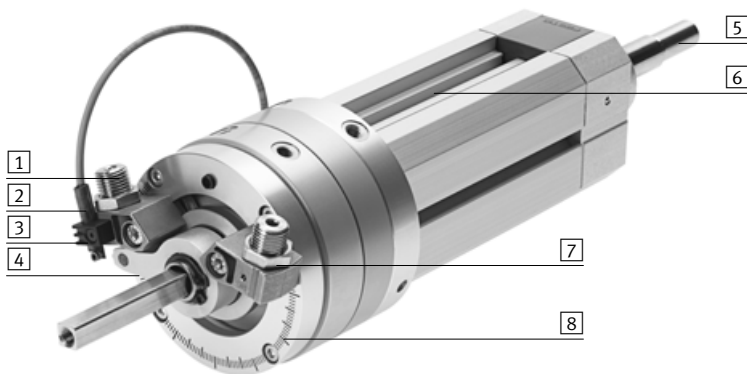

1 Cushioning

- Choice of two types of cushioning, each with metal fixed stop:
 - Flexible cushioning elements
 - Hydraulic shock absorbers

2 Position sensing

- Compact sensing of the swivel position using proximity sensors SME/SMT-10F

3 Sensor retainer

- The proximity sensors are mounted directly on the stop system. The sensor retainer can be ordered as an accessory

4 Stop lever

- The magnet in the stop lever enables the swivel angle to be sensed

5 Piston rod

Mounting interface, for example for a gripper

6 Slot for proximity sensor

- Compact sensing of the linear position using proximity sensors SME/SMT-8

7 Precision end position adjustment

- After the lock nut is loosened, precision adjustment of the end positions is possible using an Allen key

8 Angle scale

- The required angle can easily be preset using the scale

Mounting options

Direct mounting

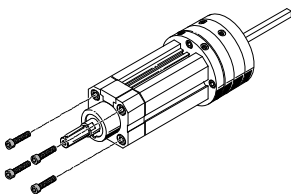

Flange mounting

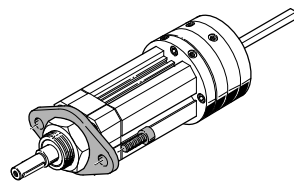

For size 16:
The mounting thread on the bearing cap complies with DIN ISO 6432.

Flange mounting

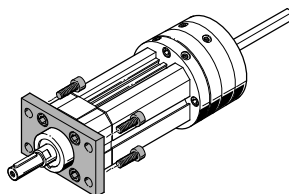

For sizes 20 ... 40:
Mounting hole pattern to DIN ISO 6431, VDMA 24 562 and NF E 49 003.1.

Via slot nuts

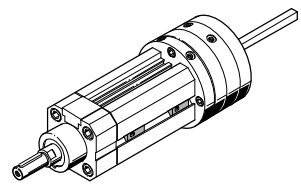

Swivel/linear drive units DSL-B

Type codes

DSL – 25 – 80 – 270 – P – A – S2 – KF – B

Type

Double-acting	
DSL	Swivel/linear drive unit

Size

Stroke [mm]

Swivel angle

270	270°
-----	------

End position cushioning

P	Flexible cushioning components at both ends
CC	Shock absorbers at both ends

Position sensing

A	Via proximity sensor
---	----------------------

Piston rod

S2	Through piston rod
S20	Through, hollow piston rod

Guide

	Plain-bearing guide
KF	Recirculating ball bearing guide

Generation

B	B series
---	----------

Swivel/linear drive units DSL-B

Peripherals overview

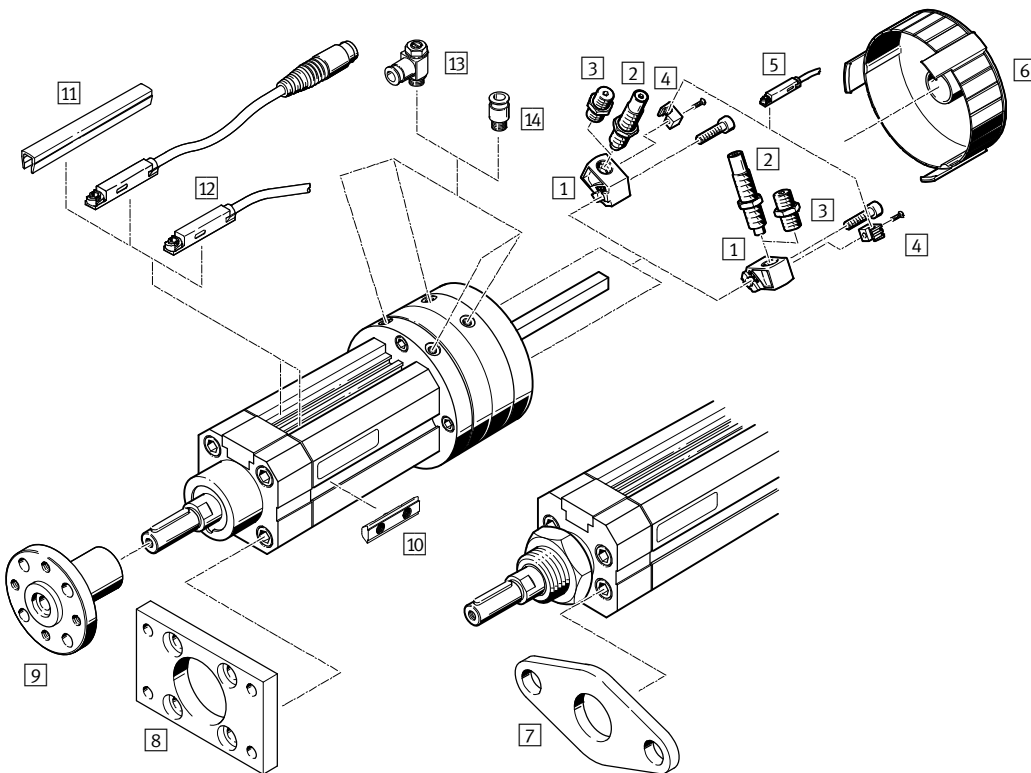

Accessories		Description	→ Page/Internet
1	Cushioning mount DSM-B	<ul style="list-style-type: none"> For flexible cushioning components For shock absorbers 	18
2	Shock absorber DYSC	Self-adjusting shock absorbers with fixed stop	18
3	Cushioning kit DSM-...-P-B	Flexible cushioning components with fixed stop	18
4	Sensor retainer SL-DSM-B	For mounting proximity sensors SME/SMT-10	19
5	Proximity sensor SME/SMT-10F	For sensing the swivel position	19
6	Cover cap AKM	Reduces the risk of injury in the swivel range of the stop lever	18
7	Flange mounting FBN	For bearing cap of swivel/linear unit DSL-16	16
8	Flange mounting FNC	For bearing cap of swivel/linear units DSL-20 ... 40	16
9	Push-on flange FWSR	For retrofitting the swivel/linear unit DSL	17
10	Slot nut NST	For mounting the drive via the linear part	17
11	Slot cover ABP	To protect the proximity sensor cable and keep dirt out of the sensor/profile slots	20
12	Proximity sensor SME/SMT-8	For sensing the linear position	19
13	One-way flow control valve GRLA	For regulating speed	18
14	Push-in fitting QS	For connecting compressed air tubing with standard outside diameter	quick star
-	Adapters	For drive/drive combinations	21
-		For drive/drive combinations	gripper

Swivel/linear drive units DSL-B

Technical data

Function

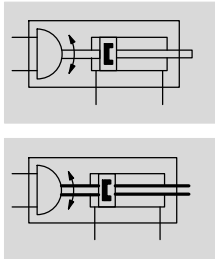



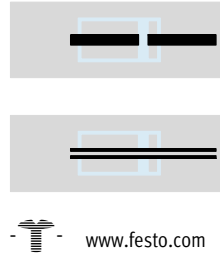

Variants

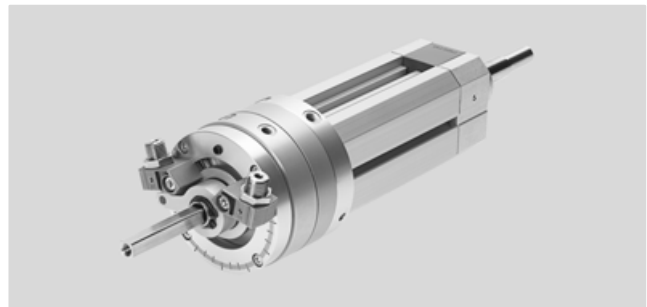

S2

S20



-  Size
16 ... 40 mm
-  Stroke length
10 ... 200 mm
-  Force
1.25 ... 20 Nm

General technical data							
Size			16	20	25	32	40
Pneumatic connection			M5			G1/8	
Constructional design			Vane-driven semi-rotary actuator in combination with a double-acting linear cylinder				
Cushioning	Swivel motion		P – Flexible cushioning components at both ends CC – Shock absorbers at both ends				
	Linear motion		P – Not adjustable at either end				
Max. swivel angle	with cushioning P	[°]	270	270	270	270	270
	with cushioning CC	[°]	246	246	246	246	240
Max. swivel angle backlash ¹⁾⁴⁾	with plain-bearing guide	[°]	2				
	with recirculating ball bearing guide	[°]	0.05				
Swivel angle adjustment ²⁾	with cushioning P	[°]	-6				
	with cushioning CC	[°]	-3				
Max. perm. swivel frequency ³⁾	with cushioning P	[Hz]	2	2	2	2	2
	with cushioning CC	[Hz]	1.5	1	1	0.7	0.7
Stroke	with plain-bearing guide	[mm]	10 ... 160			10 ... 200	
	with recirculating ball bearing guide	[mm]	10 ... 100				10 ... 160
Max. impact velocity		[mm/s]	500				
Repetition accuracy of swivel motion ⁴⁾	with cushioning P	[°]	1				
	with cushioning CC	[°]	0.1				
Position sensing			Via proximity sensor				
Type of mounting			Clamped in T-slot				
			Via external thread				
Mounting position			Any				

1) In new condition
 2) Per side
 3) At max. swivel angle
 4) Important: Where there is an external, alternating force, the swivel angle play of the respective variant (plain-bearing guide GF or recirculating ball bearing guide KF) must be added to the swivel angle.

Swivel/linear drive units DSL-B

Technical data

Operating and environmental conditions	
Operating medium	Compressed air in accordance with ISO 8573-1:2010 [7:4:4]
Note on operating/pilot medium	Operation with lubricated medium possible (in which case lubricated operation will always be required)
Operating pressure [bar]	2.5 ... 8
Ambient temperature ¹⁾ [°C]	-10 ... +60
Corrosion resistance class CRC ²⁾	1

1) Note operating range of proximity sensors.

2) Corrosion resistance class CRC 1 to Festo standard FN 940070

Low corrosion stress. For dry indoor applications or transport and storage protection. Also applies to parts behind covers, in the non-visible interior area, and parts which are covered in the application (e.g. drive trunnions).

Forces and torques						
Size		16	20	25	32	40
Theoretical torque ¹⁾	[Nm]	1.25	2.5	5	10	20
Theoretical force, advancing ¹⁾	with plain-bearing guide [N]	102.5	159	246	422.5	660
	with recirculating ball bearing guide [N]	103.5	158	248	403.5	603
Theoretical force, retracting ¹⁾	[N]	73.5	120.5	173.5	294	495
Max. perm. effective load → 7	[kg]	1	3	6	9	14

1) Theoretical values at 6 bar

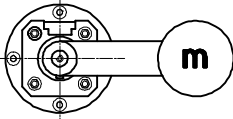
Observe max. dynamic torque load (linear motion)						
Size		16	20	25	32	40
	with plain-bearing guide [Nm]	0.1	0.2	0.45	0.8	1.1
	with recirculating ball bearing guide [Nm]	0.17	0.35	0.7	1.0	5.4

-  Note

The rotary vane is not suitable for use in defining end positions, i.e. the stop lever and the stops must not be removed.

With plain-bearing guide:

If the effective load is attached eccentrically, increased internal friction forces occur with horizontal installation, thereby causing a reduction of the effective force of the linear motion.

Weight [g]					
Size	16	20	25	32	40
Plain-bearing guide					
Cushioning P	695	1090	1510	2985	5150
Cushioning CC	697	1130	1605	3020	5205
Additional weight per 10 mm stroke	33	52	67	109	170
Recirculating ball bearing guide					
Cushioning P	745	1180	1660	3265	5300
Cushioning CC	747	1220	1755	3300	5355
Additional weight per 10 mm stroke	33	52	67	109	175

Swivel/linear drive units DSL-B

Technical data

Materials

Sectional view

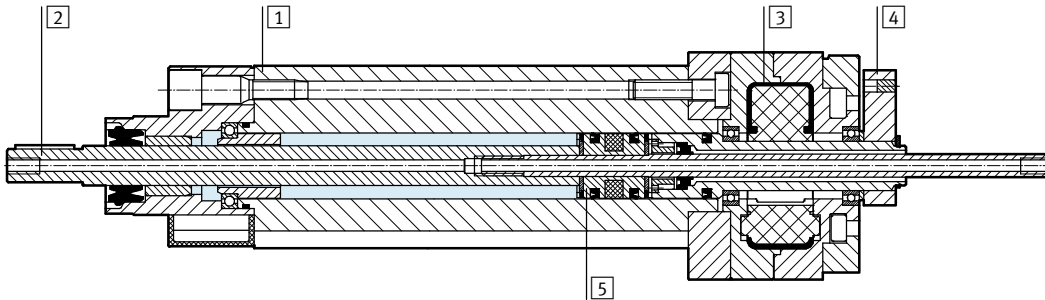

Swivel/linear drive unit		
1	Cylinder barrel, housing	Wrought aluminium alloy, smooth anodised
2	Piston rod, shaft	Stainless steel, nickel plated
3	Rotary vane	Glass fibre reinforced plastic
4	Stop lever	Anodised aluminium
5	Piston	Brass
-	Fixed stops, shock absorber retainer	Stainless steel
-	Seals	Polyurethane

Lateral force F_q as a function of stroke length l

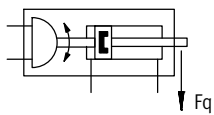

- Piston rod with bearings at both ends
- Resists high torques and lateral forces

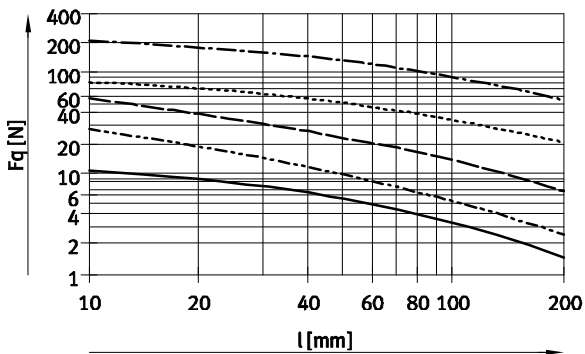

- $\varnothing 16$
- - - $\varnothing 20$
- · - $\varnothing 25$
- · · $\varnothing 32$
- - - $\varnothing 40$

Max. permissible effective load as a function of piston speed v

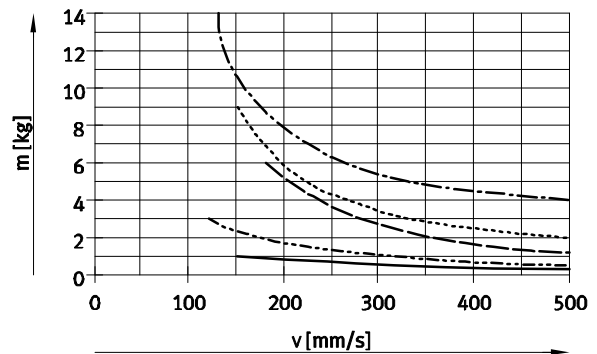
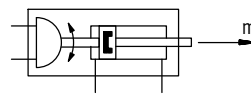

- $\varnothing 16$
- - - $\varnothing 20$
- · - $\varnothing 25$
- · · $\varnothing 32$
- - - $\varnothing 40$

Swivel/linear drive units DSL-B

Technical data

Max. permissible mass moment of inertia J as a function of swivel time t

DSL-16-...-P

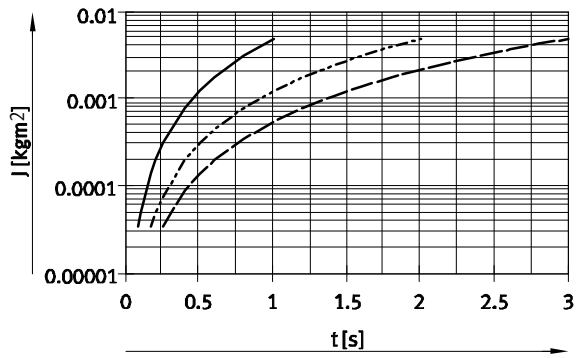

DSL-16-...-CC

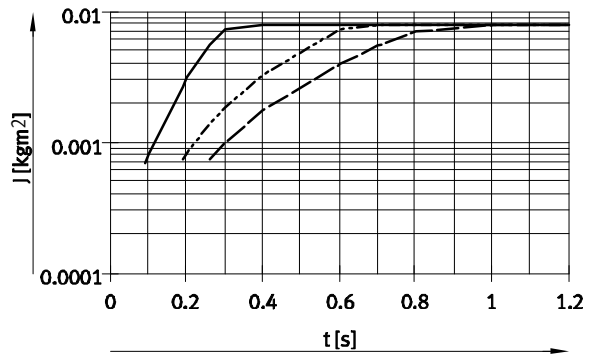

DSL-20-...-P

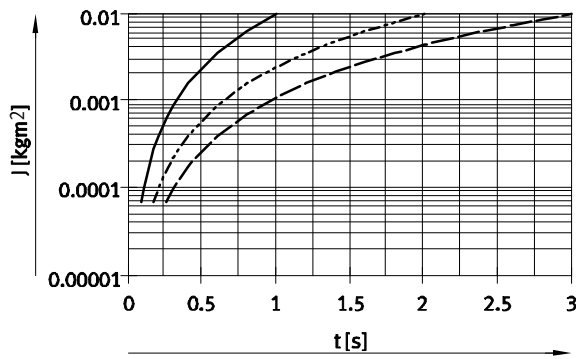

DSL-20-...-CC

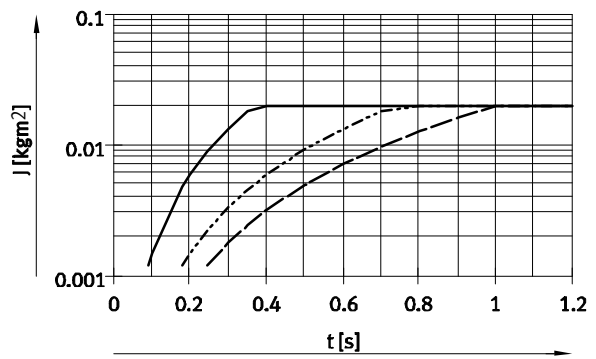

DSL-25-...-P

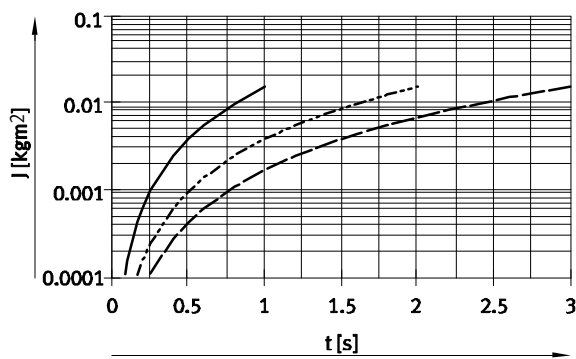

DSL-25-...-CC

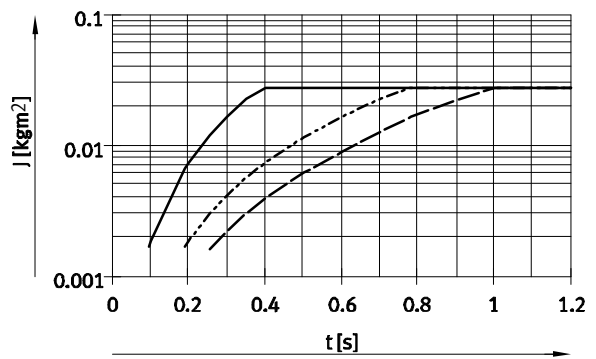

- 90°
- - - 180°
- · - · 270°

Swivel/linear drive units DSL-B

Technical data

Max. permissible mass moment of inertia J as a function of swivel time t

DSL-32-...-P

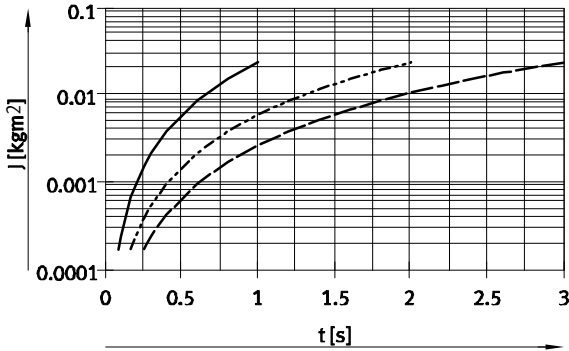

DSL-32-...-CC

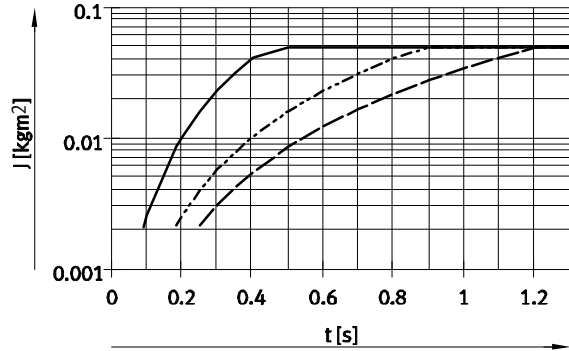

DSL-40-...-P

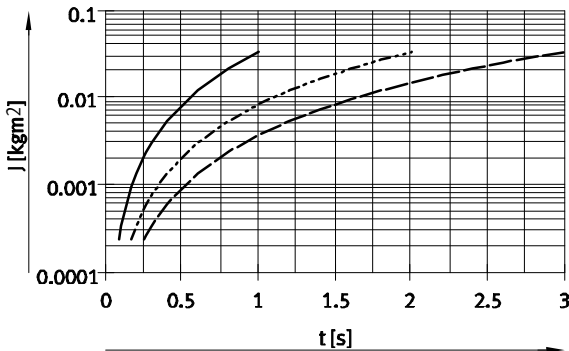

DSL-40-...-CC

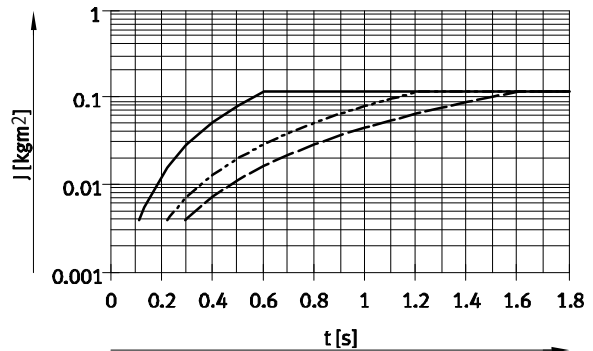

- 90°
- - - 180°
- · - 270°

In the graphs for the types DSL-...-CC, the swivel time is shown up to the point when the stop lever meets the shock absorber. The cushioning time of the shock absorber must be added in order to obtain total swivel time.

Cushioning time of the shock absorber

Size	16/20/25	32	40
Cushioning time [s]	0.1	0.25	0.3

- Note

Sizing software
Calculating inertia
→ www.festo.com

Swivel/linear drive units DSL-B

Technical data

FESTO

Dimensions

Download CAD data → www.festo.com

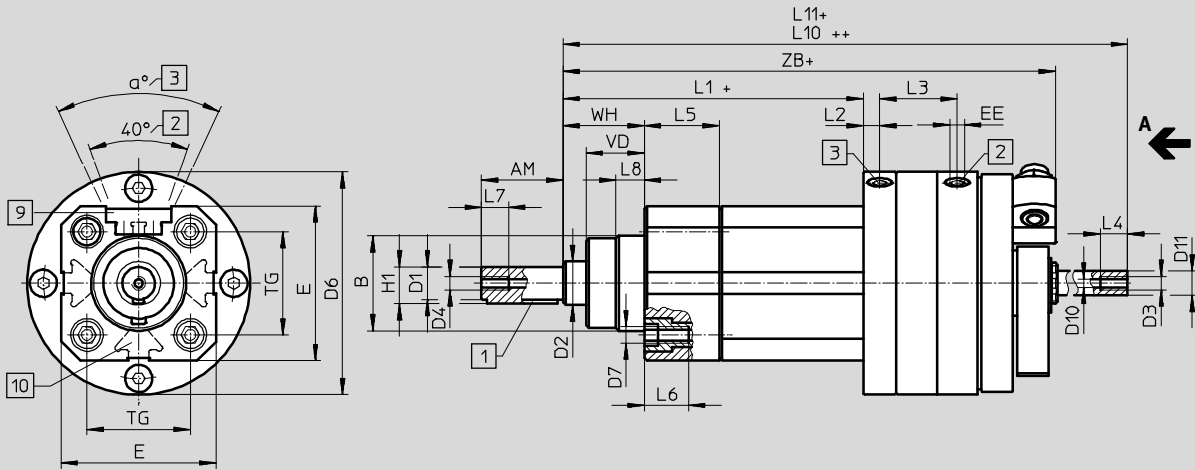

View A

Variant P

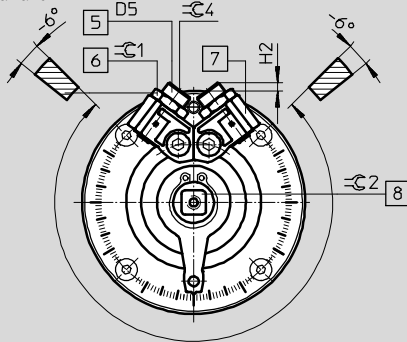

Piston Ø 16 mm

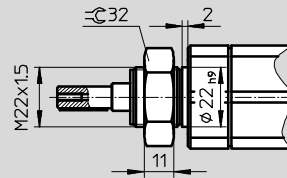
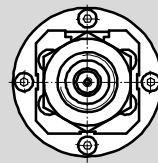

Variant CC

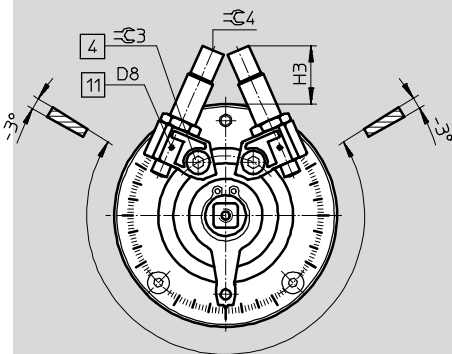

- | | | | |
|-------------------------------|--|---------------------------------------|--|
| 1 Woodruff key position at 0° | 4 Locking screw for clamping the stop | 7 Infinitely adjustable fixed stops | 10 Mounting slots |
| 2 Supply port, rotary part | 5 End position adjustment | 8 Manual override (square) | 11 Mounting thread for sensor retainer |
| 3 Supply port, linear part | 6 Lock nut for end position adjustment | 9 Slot for proximity sensor SME/SMT-8 | |
- + = plus stroke length
++ = plus 2 stroke lengths

Swivel/linear drive units DSL-B

Technical data

Size	AM	B ∅ d11	D1 ∅ g7	D2 ∅ f8	D3 ¹⁾		D4		D5	D6 ∅ ±0.2	D7	D8
					S2	S20	S2	S20				
16	20 ^{+0.2}	–	8	10	M3	M3	M3	M3	M8x1	58	–	M2
20	23 ^{+0.2}	30	10	12	M5	M5	M5	M5	M10x1	69	M6	M2
25	30 ^{+0.2}	35	12	16	M5	M5	M5	M5	M10x1	82	M6	M2
32	40 ^{+0.3}	40	16	20	M5	M5	M5	M5	M12x1	104	M8	M2
40	50 ^{+0.3}	45	20	25	M6	M7	M6	M7	M16x1	128	M8	M2

Size	D11 ¹⁾	E	EE	H1 max.	H2	H3	L1 ¹⁾	L2 ±0.2	L3	L4
20	–	50	M5	11.2	8.1	27.7	95 ^{+1.1/-1.3}	6	26.2 ^{+0.6}	10 ⁺¹
25	–	57	M5	13.5	4	22	100.5 ^{+1.2/-1.3}	6	29.5 ^{+0.6}	10 ⁺¹
32	–	72	G ¹ / ₈	18	6	30.5	111 ^{+1.3/-1.4}	9	39.5 ^{+0.6}	12.5 ⁺²
40	–	83.5	G ¹ / ₈	22.5	5.7	45.5	132 ^{+1.3/-1.4}	9	44.7 ^{+0.6}	6.5 ⁺²

Size	L5	L6 +2	L7	L8 ±0.3	L10 ¹⁾	TG	VD	WH	ZB ¹⁾
20	26 ^{-0.2}	17	10 ⁺¹	10.5	175 ^{+0.8/-0.1}	32.5	19 ^{+0.2}	26 ^{+1.3/-1.7}	161.8 ^{+1.4/-1.5}
25	27.5 ^{-0.2}	17	10 ⁺¹	10.5	186.5 ^{+0.8/-0.1}	38	21.5 ^{+0.2}	30 ^{+1.4/-1.7}	173.4 ^{+1.4/-1.2}
32	28.5 ^{-0.2}	21	12.5 ⁺²	12	224 ^{+0.6/-0.2}	46.5	28.5 ^{+0.3}	37 ^{+1.4/-1.8}	205 ^{+1.5/-1.9}
40	35 ^{-0.2}	18	14 ⁺²	15	263 ^{+0.6/-0.2}	56.5	34.7 ^{+0.3}	46 ^{+1.4/-1.8}	243.5 ^{+1.8/-1.9}

Size	α	≈C1	≈C2	≈C3	≈C4	Woodruff key to DIN 6885	D10 min. ∅ S20
20	50°	13	7	3	3	A3x3x18	3.2
25	50°	13	9	4	3	A4x4x25	4.2
32	50°	15	10	5	4	A5x5x36	4.2
40	50°	19	12	8	5	A6x6x45	5.6

1) Deviating dimensions for variant with recirculating ball bearing guide KF

Size	Stroke	D3		D11 ∅ h7	L1	L11		ZB
		S2	S20			S2 +0.8/-0.1	S20 +0.8/-0.1	
16	25	–	M3	6	104 ^{+1.1/-1.3}	*	198	159.6 ^{+1.4/-1.5}
	≤ 50					*	223	
	> 50					213	273	
20	≤ 50	–	M5	8	111 ^{+1.1/-1.3}	*	241	177.7 ^{+1.4/-1.5}
	> 50					225	291	
25	≤ 50	–	M5	10	129 ^{+1.2/-1.3}	*	266	201.2 ^{+1.4/-1.2}
	> 50					238	316	
32	≤ 50	–	M7	13	143 ^{+1.3/-1.4}	*	305	237 ^{+1.5/-1.9}
	> 50					253	355	
40	≤ 50	–	G ¹ / ₈	16	182 ^{+1.3/-1.4}	*	364	293.5 ^{+1.5/-1.9}
	> 50					*	414	
	> 100					352	464	

*) Profile rod does not protrude beyond the drive unit

Swivel/linear drive units DSL-B

Technical data

Ordering data – With plain bearing guide							
Version	Size	Stroke [mm]	P – Flexible cushioning components at both ends		CC – Shock absorbers at both ends		
			Part No.	Type	Part No.	Type	
S2 – Through piston rod							
	16	25	556390	DSL-16-25-270-P-A-S2-B	556391	DSL-16-25-270-CC-A-S2-B	
		40	556396	DSL-16-40-270-P-A-S2-B	556397	DSL-16-40-270-CC-A-S2-B	
		50	556402	DSL-16-50-270-P-A-S2-B	556403	DSL-16-50-270-CC-A-S2-B	
		80	556408	DSL-16-80-270-P-A-S2-B	556409	DSL-16-80-270-CC-A-S2-B	
		100	556414	DSL-16-100-270-P-A-S2-B	556415	DSL-16-100-270-CC-A-S2-B	
		10 ... 160	556420	DSL-16-...-270-P-A-S2-B	556421	DSL-16-...-270-CC-A-S2-B	
	20	25	556426	DSL-20-25-270-P-A-S2-B	556427	DSL-20-25-270-CC-A-S2-B	
		40	556432	DSL-20-40-270-P-A-S2-B	556433	DSL-20-40-270-CC-A-S2-B	
		50	556438	DSL-20-50-270-P-A-S2-B	556439	DSL-20-50-270-CC-A-S2-B	
		80	556444	DSL-20-80-270-P-A-S2-B	556445	DSL-20-80-270-CC-A-S2-B	
		100	556450	DSL-20-100-270-P-A-S2-B	556451	DSL-20-100-270-CC-A-S2-B	
		10 ... 160	556456	DSL-20-...-270-P-A-S2-B	556457	DSL-20-...-270-CC-A-S2-B	
	25	25	556462	DSL-25-25-270-P-A-S2-B	556463	DSL-25-25-270-CC-A-S2-B	
		40	556468	DSL-25-40-270-P-A-S2-B	556469	DSL-25-40-270-CC-A-S2-B	
		50	556474	DSL-25-50-270-P-A-S2-B	556475	DSL-25-50-270-CC-A-S2-B	
		80	556480	DSL-25-80-270-P-A-S2-B	556481	DSL-25-80-270-CC-A-S2-B	
		100	556486	DSL-25-100-270-P-A-S2-B	556487	DSL-25-100-270-CC-A-S2-B	
		10 ... 160	556492	DSL-25-...-270-P-A-S2-B	556493	DSL-25-...-270-CC-A-S2-B	
	32	25	556498	DSL-32-25-270-P-A-S2-B	556499	DSL-32-25-270-CC-A-S2-B	
		40	556504	DSL-32-40-270-P-A-S2-B	556505	DSL-32-40-270-CC-A-S2-B	
		50	556510	DSL-32-50-270-P-A-S2-B	556511	DSL-32-50-270-CC-A-S2-B	
		80	556516	DSL-32-80-270-P-A-S2-B	556517	DSL-32-80-270-CC-A-S2-B	
		100	556522	DSL-32-100-270-P-A-S2-B	556523	DSL-32-100-270-CC-A-S2-B	
		10 ... 200	556528	DSL-32-...-270-P-A-S2-B	556529	DSL-32-...-270-CC-A-S2-B	
	40	25	556534	DSL-40-25-270-P-A-S2-B	556535	DSL-40-25-270-CC-A-S2-B	
		40	556540	DSL-40-40-270-P-A-S2-B	556541	DSL-40-40-270-CC-A-S2-B	
		50	556546	DSL-40-50-270-P-A-S2-B	556547	DSL-40-50-270-CC-A-S2-B	
		80	556552	DSL-40-80-270-P-A-S2-B	556553	DSL-40-80-270-CC-A-S2-B	
		100	556558	DSL-40-100-270-P-A-S2-B	556559	DSL-40-100-270-CC-A-S2-B	
		125	556564	DSL-40-125-270-P-A-S2-B	556565	DSL-40-125-270-CC-A-S2-B	
		160	556570	DSL-40-160-270-P-A-S2-B	556571	DSL-40-160-270-CC-A-S2-B	
		10 ... 200	556576	DSL-40-...-270-P-A-S2-B	556577	DSL-40-...-270-CC-A-S2-B	

Swivel/linear drive units DSL-B

Technical data

Ordering data – With plain bearing guide						
Version	Size	Stroke [mm]	P – Flexible cushioning components at both ends		CC – Shock absorbers at both ends	
			Part No.	Type	Part No.	Type
S20 – Through, hollow piston rod						
	16	25	556393	DSL-16-25-270-P-A-S20-B	556394	DSL-16-25-270-CC-A-S20-B
		40	556399	DSL-16-40-270-P-A-S20-B	556400	DSL-16-40-270-CC-A-S20-B
		50	556405	DSL-16-50-270-P-A-S20-B	556406	DSL-16-50-270-CC-A-S20-B
		80	556411	DSL-16-80-270-P-A-S20-B	556412	DSL-16-80-270-CC-A-S20-B
		100	556417	DSL-16-100-270-P-A-S20-B	556418	DSL-16-100-270-CC-A-S20-B
		10 ... 160	556423	DSL-16-...-270-P-A-S20-B	556424	DSL-16-...-270-CC-A-S20-B
	20	25	556429	DSL-20-25-270-P-A-S20-B	556430	DSL-20-25-270-CC-A-S20-B
		40	556435	DSL-20-40-270-P-A-S20-B	556436	DSL-20-40-270-CC-A-S20-B
		50	556441	DSL-20-50-270-P-A-S20-B	556442	DSL-20-50-270-CC-A-S20-B
		80	556447	DSL-20-80-270-P-A-S20-B	556448	DSL-20-80-270-CC-A-S20-B
		100	556453	DSL-20-100-270-P-A-S20-B	556454	DSL-20-100-270-CC-A-S20-B
		10 ... 160	556459	DSL-20-...-270-P-A-S20-B	556460	DSL-20-...-270-CC-A-S20-B
	25	25	556465	DSL-25-25-270-P-A-S20-B	556466	DSL-25-25-270-CC-A-S20-B
		40	556471	DSL-25-40-270-P-A-S20-B	556472	DSL-25-40-270-CC-A-S20-B
		50	556477	DSL-25-50-270-P-A-S20-B	556478	DSL-25-50-270-CC-A-S20-B
		80	556483	DSL-25-80-270-P-A-S20-B	556484	DSL-25-80-270-CC-A-S20-B
		100	556489	DSL-25-100-270-P-A-S20-B	556490	DSL-25-100-270-CC-A-S20-B
		10 ... 160	556495	DSL-25-...-270-P-A-S20-B	556496	DSL-25-...-270-CC-A-S20-B
	32	25	556501	DSL-32-25-270-P-A-S20-B	556502	DSL-32-25-270-CC-A-S20-B
		40	556507	DSL-32-40-270-P-A-S20-B	556508	DSL-32-40-270-CC-A-S20-B
		50	556513	DSL-32-50-270-P-A-S20-B	556514	DSL-32-50-270-CC-A-S20-B
		80	556519	DSL-32-80-270-P-A-S20-B	556520	DSL-32-80-270-CC-A-S20-B
		100	556525	DSL-32-100-270-P-A-S20-B	556526	DSL-32-100-270-CC-A-S20-B
		10 ... 200	556531	DSL-32-...-270-P-A-S20-B	556532	DSL-32-...-270-CC-A-S20-B
	40	25	556537	DSL-40-25-270-P-A-S20-B	556538	DSL-40-25-270-CC-A-S20-B
		40	556543	DSL-40-40-270-P-A-S20-B	556544	DSL-40-40-270-CC-A-S20-B
		50	556549	DSL-40-50-270-P-A-S20-B	556550	DSL-40-50-270-CC-A-S20-B
		80	556555	DSL-40-80-270-P-A-S20-B	556556	DSL-40-80-270-CC-A-S20-B
		100	556561	DSL-40-100-270-P-A-S20-B	556562	DSL-40-100-270-CC-A-S20-B
		125	556567	DSL-40-125-270-P-A-S20-B	556568	DSL-40-125-270-CC-A-S20-B
		160	556573	DSL-40-160-270-P-A-S20-B	556574	DSL-40-160-270-CC-A-S20-B
		10 ... 200	556579	DSL-40-...-270-P-A-S20-B	556580	DSL-40-...-270-CC-A-S20-B

Swivel/linear drive units DSL-B

Technical data

Ordering data – With recirculating ball bearing guide							
Version	Size	Stroke [mm]	P – Flexible cushioning components at both ends		CC – Shock absorbers at both ends		
			Part No.	Type	Part No.	Type	
S2 – Through piston rod							
	16	25	556582	DSL-16-25-270-P-A-S2-KF-B	556583	DSL-16-25-270-CC-A-S2-KF-B	
		40	556588	DSL-16-40-270-P-A-S2-KF-B	556589	DSL-16-40-270-CC-A-S2-KF-B	
		50	556594	DSL-16-50-270-P-A-S2-KF-B	556595	DSL-16-50-270-CC-A-S2-KF-B	
		80	556600	DSL-16-80-270-P-A-S2-KF-B	556601	DSL-16-80-270-CC-A-S2-KF-B	
		100	556606	DSL-16-100-270-P-A-S2-KF-B	556607	DSL-16-100-270-CC-A-S2-KF-B	
		10 ... 100	556612	DSL-16-...-270-P-A-S2-KF-B	556613	DSL-16-...-270-CC-A-S2-KF-B	
	20	25	556618	DSL-20-25-270-P-A-S2-KF-B	556619	DSL-20-25-270-CC-A-S2-KF-B	
		40	556624	DSL-20-40-270-P-A-S2-KF-B	556625	DSL-20-40-270-CC-A-S2-KF-B	
		50	556630	DSL-20-50-270-P-A-S2-KF-B	556631	DSL-20-50-270-CC-A-S2-KF-B	
		80	556636	DSL-20-80-270-P-A-S2-KF-B	556637	DSL-20-80-270-CC-A-S2-KF-B	
		100	556642	DSL-20-100-270-P-A-S2-KF-B	556643	DSL-20-100-270-CC-A-S2-KF-B	
		10 ... 100	556648	DSL-20-...-270-P-A-S2-KF-B	556649	DSL-20-...-270-CC-A-S2-KF-B	
	25	25	556654	DSL-25-25-270-P-A-S2-KF-B	556655	DSL-25-25-270-CC-A-S2-KF-B	
		40	556660	DSL-25-40-270-P-A-S2-KF-B	556661	DSL-25-40-270-CC-A-S2-KF-B	
		50	556666	DSL-25-50-270-P-A-S2-KF-B	556667	DSL-25-50-270-CC-A-S2-KF-B	
		80	556672	DSL-25-80-270-P-A-S2-KF-B	556673	DSL-25-80-270-CC-A-S2-KF-B	
		100	556678	DSL-25-100-270-P-A-S2-KF-B	556679	DSL-25-100-270-CC-A-S2-KF-B	
		10 ... 100	556684	DSL-25-...-270-P-A-S2-KF-B	556685	DSL-25-...-270-CC-A-S2-KF-B	
	32	25	556690	DSL-32-25-270-P-A-S2-KF-B	556691	DSL-32-25-270-CC-A-S2-KF-B	
		40	556696	DSL-32-40-270-P-A-S2-KF-B	556697	DSL-32-40-270-CC-A-S2-KF-B	
		50	556702	DSL-32-50-270-P-A-S2-KF-B	556703	DSL-32-50-270-CC-A-S2-KF-B	
		80	556708	DSL-32-80-270-P-A-S2-KF-B	556709	DSL-32-80-270-CC-A-S2-KF-B	
		100	556714	DSL-32-100-270-P-A-S2-KF-B	556715	DSL-32-100-270-CC-A-S2-KF-B	
		10 ... 100	556720	DSL-32-...-270-P-A-S2-KF-B	556721	DSL-32-...-270-CC-A-S2-KF-B	
	40	25	556726	DSL-40-25-270-P-A-S2-KF-B	556727	DSL-40-25-270-CC-A-S2-KF-B	
		40	556732	DSL-40-40-270-P-A-S2-KF-B	556733	DSL-40-40-270-CC-A-S2-KF-B	
		50	556738	DSL-40-50-270-P-A-S2-KF-B	556739	DSL-40-50-270-CC-A-S2-KF-B	
		80	556744	DSL-40-80-270-P-A-S2-KF-B	556745	DSL-40-80-270-CC-A-S2-KF-B	
		100	556750	DSL-40-100-270-P-A-S2-KF-B	556751	DSL-40-100-270-CC-A-S2-KF-B	
		125	556756	DSL-40-125-270-P-A-S2-KF-B	556757	DSL-40-125-270-CC-A-S2-KF-B	
		160	556762	DSL-40-160-270-P-A-S2-KF-B	556763	DSL-40-160-270-CC-A-S2-KF-B	
		10 ... 160	556768	DSL-40-...-270-P-A-S2-KF-B	556769	DSL-40-...-270-CC-A-S2-KF-B	

Swivel/linear drive units DSL-B

Technical data

Ordering data – With recirculating ball bearing guide						
Version	Size	Stroke [mm]	P – Flexible cushioning components at both ends		CC – Shock absorbers at both ends	
			Part No.	Type	Part No.	Type
S20 – Through, hollow piston rod						
	16	25	556585	DSL-16-25-270-P-A-S20-KF-B	556586	DSL-16-25-270-CC-A-S20-KF-B
		40	556591	DSL-16-40-270-P-A-S20-KF-B	556592	DSL-16-40-270-CC-A-S20-KF-B
		50	556597	DSL-16-50-270-P-A-S20-KF-B	556598	DSL-16-50-270-CC-A-S20-KF-B
		80	556603	DSL-16-80-270-P-A-S20-KF-B	556604	DSL-16-80-270-CC-A-S20-KF-B
		100	556609	DSL-16-100-270-P-A-S20-KF-B	556610	DSL-16-100-270-CC-A-S20-KF-B
		10 ... 100	556615	DSL-16-...-270-P-A-S20-KF-B	556616	DSL-16-...-270-CC-A-S20-KF-B
	20	25	556621	DSL-20-25-270-P-A-S20-KF-B	556622	DSL-20-25-270-CC-A-S20-KF-B
		40	556627	DSL-20-40-270-P-A-S20-KF-B	556628	DSL-20-40-270-CC-A-S20-KF-B
		50	556633	DSL-20-50-270-P-A-S20-KF-B	556634	DSL-20-50-270-CC-A-S20-KF-B
		80	556639	DSL-20-80-270-P-A-S20-KF-B	556640	DSL-20-80-270-CC-A-S20-KF-B
		100	556645	DSL-20-100-270-P-A-S20-KF-B	556646	DSL-20-100-270-CC-A-S20-KF-B
		10 ... 100	556651	DSL-20-...-270-P-A-S20-KF-B	556652	DSL-20-...-270-CC-A-S20-KF-B
	25	25	556657	DSL-25-25-270-P-A-S20-KF-B	556658	DSL-25-25-270-CC-A-S20-KF-B
		40	556663	DSL-25-40-270-P-A-S20-KF-B	556664	DSL-25-40-270-CC-A-S20-KF-B
		50	556669	DSL-25-50-270-P-A-S20-KF-B	556670	DSL-25-50-270-CC-A-S20-KF-B
		80	556675	DSL-25-80-270-P-A-S20-KF-B	556676	DSL-25-80-270-CC-A-S20-KF-B
		100	556681	DSL-25-100-270-P-A-S20-KF-B	556682	DSL-25-100-270-CC-A-S20-KF-B
		10 ... 100	556687	DSL-25-...-270-P-A-S20-KF-B	556688	DSL-25-...-270-CC-A-S20-KF-B
	32	25	556693	DSL-32-25-270-P-A-S20-KF-B	556694	DSL-32-25-270-CC-A-S20-KF-B
		40	556699	DSL-32-40-270-P-A-S20-KF-B	556700	DSL-32-40-270-CC-A-S20-KF-B
		50	556705	DSL-32-50-270-P-A-S20-KF-B	556706	DSL-32-50-270-CC-A-S20-KF-B
		80	556711	DSL-32-80-270-P-A-S20-KF-B	556712	DSL-32-80-270-CC-A-S20-KF-B
		100	556717	DSL-32-100-270-P-A-S20-KF-B	556718	DSL-32-100-270-CC-A-S20-KF-B
		10 ... 100	556723	DSL-32-...-270-P-A-S20-KF-B	556724	DSL-32-...-270-CC-A-S20-KF-B
	40	25	556729	DSL-40-25-270-P-A-S20-KF-B	556730	DSL-40-25-270-CC-A-S20-KF-B
		40	556735	DSL-40-40-270-P-A-S20-KF-B	556736	DSL-40-40-270-CC-A-S20-KF-B
		50	556741	DSL-40-50-270-P-A-S20-KF-B	556742	DSL-40-50-270-CC-A-S20-KF-B
		80	556747	DSL-40-80-270-P-A-S20-KF-B	556748	DSL-40-80-270-CC-A-S20-KF-B
		100	556753	DSL-40-100-270-P-A-S20-KF-B	556754	DSL-40-100-270-CC-A-S20-KF-B
		125	556759	DSL-40-125-270-P-A-S20-KF-B	556760	DSL-40-125-270-CC-A-S20-KF-B
		160	556765	DSL-40-160-270-P-A-S20-KF-B	556766	DSL-40-160-270-CC-A-S20-KF-B
		10 ... 160	556771	DSL-40-...-270-P-A-S20-KF-B	556772	DSL-40-...-270-CC-A-S20-KF-B

Swivel/linear drive units DSL-B

Accessories

Flange mounting FBN

Material:
Galvanised steel
Free of copper and PTFE

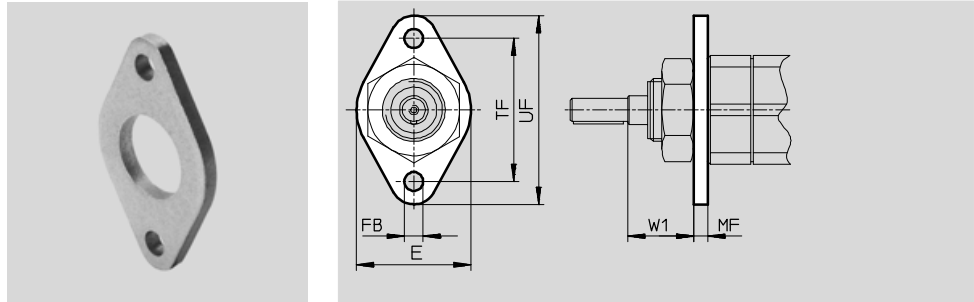

Dimensions and ordering data										
For size	E	FB ∅ H13	MF	TF	UF	W1	CRC ¹⁾	Weight [g]	Part No.	Type
16	40	6.6	5	50	66	23	2	52	5131	FBN-20/25

1) Corrosion resistance class CRC 2 to Festo standard FN 940070
Moderate corrosion stress. Indoor applications in which condensation may occur. External visible parts with primarily decorative requirements for the surface and which are in direct contact with the ambient atmosphere typical for industrial applications.

Flange mounting FNC

Material:
Galvanised steel
Free of copper and PTFE

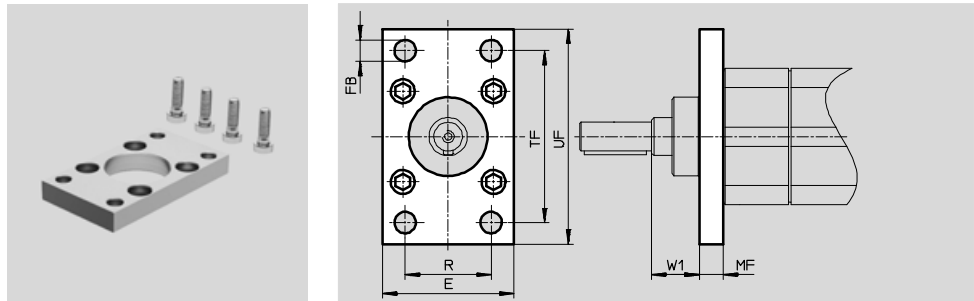

Dimensions and ordering data											
For size	E	FB ∅ H13	MF	R	TF	UF	W1	CRC ¹⁾	Weight [g]	Part No.	Type
20	45	7	10	32	64	80	16	1	221	174376	FNC-32
25	54	9	10	36	72	90	20	1	291	174377	FNC-40
32	65	9	12	45	90	110	25	1	536	174378	FNC-50
40	75	9	12	50	100	120	34	1	679	174379	FNC-63

1) Corrosion resistance class CRC 1 to Festo standard FN 940070
Low corrosion stress. For dry indoor applications or transport and storage protection. Also applies to parts behind covers, in the non-visible interior area, and parts which are covered in the application (e.g. drive trunnions).

Swivel/linear drive units DSL-B

Accessories

Slot nut NST

Material:
Tempered steel, non-alloyed
Free of copper and PTFE

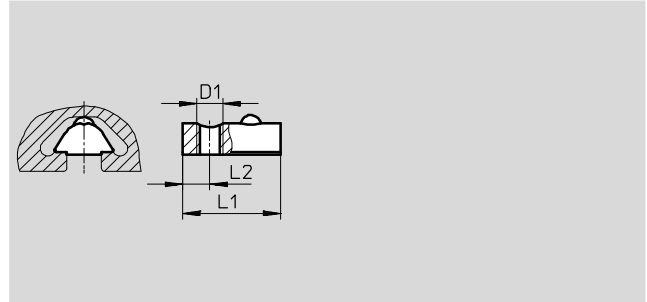

Dimensions and ordering data							
For size	D1	L1	L2	CRC ¹⁾	Weight [g]	Part No.	Type
16	M5	12	4	2	3	150914	NST-5-M5
20							
25	M6	22.5	6.25	2	11	150915	NST-8-M6
32							
40							

1) Corrosion resistance class CRC 2 to Festo standard FN 940070
Moderate corrosion stress. Indoor applications in which condensation may occur. External visible parts with primarily decorative requirements for the surface and which are in direct contact with the ambient atmosphere typical for industrial applications.

Push-on flange FWSR

The permissible tightening torque must not be exceeded when attaching additional components to the spigot shaft.

Material:
Wrought aluminium alloy, anodised
Free of copper and PTFE

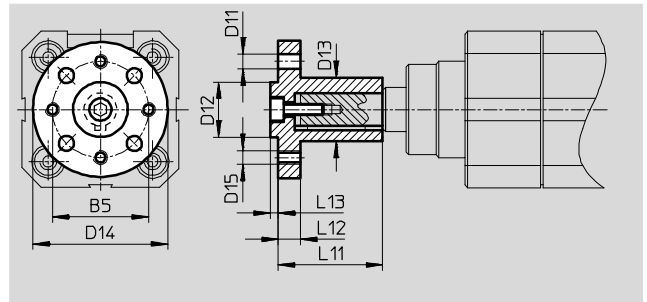

Dimensions and ordering data														
For size	B5	D11 H13 ∅	D12 f8 ∅	D13 ∅	D14 ∅	D15	L11	L12	L13	Tightening torque [Nm]	CRC ¹⁾	Weight [g]	Part No.	Type
16	25	3.4	14	15	35	M3	25	3	3	1.2	2	21	14659	FWSR-12
20	28	4.5	16	17	40	M4	28	5	6	5.5	2	32	170153	FWSR-16-M5
25	35	5.5	20	23	50	M5	38	8	3	5.5	2	70	170154	FWSR-25-M5
32	45	6.6	28	28	60	M6	48	10	4	5.5	2	127	13241	FWSR-32
40	54	9	36	38	70	M8	60	11	5	10	2	240	14656	FWSR-40

1) Corrosion resistance class CRC 2 to Festo standard FN 940070
Moderate corrosion stress. Indoor applications in which condensation may occur. External visible parts with primarily decorative requirements for the surface and which are in direct contact with the ambient atmosphere typical for industrial applications.

Swivel/linear drive units DSL-B

Accessories

Cover cap AKM

Material:
Polyamide

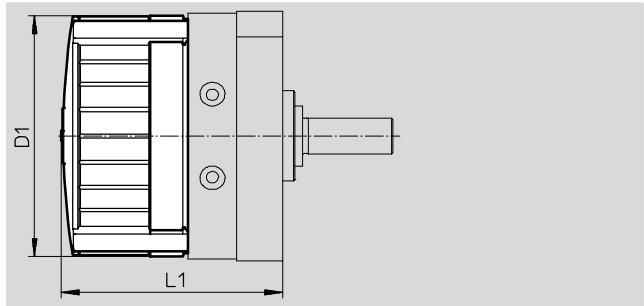
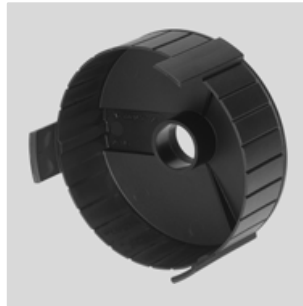

Dimensions and ordering data					
For size	D1		L1	Part No.	Type
	∅				
16	59		56.2±1.2	549194	AKM-12
20	70		68±1.2	549195	AKM-16
25	83		73.4±1.2	549196	AKM-25
32	105		89.7±1.5	549197	AKM-32
40	130		107.1±1.5	549198	AKM-40

Ordering data – Cushioning kits					
	For size	Remarks	Part No.	Type	
	16	For cushioning mount DSM-...-B	550657	DSM-12-P-B	
	20, 25		550658	DSM-16/25-P-B	
	32		550659	DSM-32-P-B	
	40		550660	DSM-40-P-B	

Ordering data – Shock absorbers					
	For size	Remarks	Part No.	Type	Technical data → Internet: dycs
	16	For cushioning mount DSM-...-B	548011	DYSC-5-5-Y1F	
	20, 25		548012	DYSC-7-5-Y1F	
	32		548013	DYSC-8-8-Y1F	
	40		548014	DYSC-12-12-Y1F	

Ordering data – Cushioning mounts					
	For size	Remarks	Part No.	Type	
	16	<ul style="list-style-type: none"> For flexible cushioning components For shock absorbers 	547900	DSM-12-B	
	20		547901	DSM-16-B	
	25		547902	DSM-25-B	
	32		547903	DSM-32-B	
	40		547904	DSM-40-B	

Ordering data – One-way flow control valves					
	Connection		Material	Part No.	Type
	Thread	For tubing O.D.			
For exhaust air					
	M5	3	Metal design	193137	GRLA-M5-QS-3-D
		4		193138	GRLA-M5-QS-4-D
		6		193139	GRLA-M5-QS-6-D
	G1/8	3		193142	GRLA-1/8-QS-3-D
		4		193143	GRLA-1/8-QS-4-D
		6		193144	GRLA-1/8-QS-6-D
		8		193145	GRLA-1/8-QS-8-D

Swivel/linear drive units DSL-B



Accessories



FESTO

Ordering data – Sensor retainer						
	For size	Remarks	Part No.	Type		
	16, 20, 25, 32, 40	Can only be used in combination with proximity sensors SME-/SMT-10F	550661	SL-DSM-B		

Ordering data – Proximity sensors for C-slot, magneto-resistive						Technical data → Internet: smt-10	
	Type of mounting	Switching output	Electrical connection, connection direction	Cable length [m]	Part No.	Type	
N/O contact							
	Is clamped to the DSL-B using the sensor retainer	PNP	Cable, 3-wire, in-line	2.5	551373	SMT-10M-PS-24V-E-2,5-L-OE	
			Plug M8x1, 3-pin, in-line	0.3	551375	SMT-10M-PS-24V-E-0,3-L-M8D	

Ordering data – Proximity sensors for C-slot, magnetic reed						Technical data → Internet: sme-10	
	Type of mounting	Switching output	Electrical connection, connection direction	Cable length [m]	Part No.	Type	
N/O contact							
	Is clamped to the DSL-B using the sensor retainer	Contacting	Plug M8x1, 3-pin, in-line	0.3	551367	SME-10M-DS-24V-E-0,3-L-M8D	
			Cable, 3-wire, in-line	2.5	551365	SME-10M-DS-24V-E-2,5-L-OE	
			Cable, 2-wire, in-line	2.5	551369	SME-10M-ZS-24V-E-2,5-L-OE	



Ordering data – Proximity sensors for T-slot, magneto-resistive						Technical data → Internet: smt	
	Type of mounting	Switch output	Electrical connection	Cable length [m]	Part No.	Type	
N/O contact							
	Insertable in the slot from above, flush with cylinder profile, short design	PNP	Cable, 3-wire	2.5	574335	SMT-8M-A-PS-24V-E-2,5-OE	
			Plug M8x1, 3-pin	0.3	574334	SMT-8M-A-PS-24V-E-0,3-M8D	
			Plug M12x1, 3-pin	0.3	574337	SMT-8M-A-PS-24V-E-0,3-M12	
		NPN	Cable, 3-wire	2.5	574338	SMT-8M-A-NS-24V-E-2,5-OE	
			Plug M8x1, 3-pin	0.3	574339	SMT-8M-A-NS-24V-E-0,3-M8D	
N/C contact							
	Insertable in the slot from above, flush with cylinder profile, short design	PNP	Cable, 3-wire	7.5	574340	SMT-8M-A-PO-24V-E-7,5-OE	

Ordering data – Proximity sensors for T-slot, magnetic reed						Technical data → Internet: sme-8	
	Type of mounting	Switching output	Electrical connection	Cable length [m]	Part No.	Type	
N/O contact							
	Insertable in the slot from above, flush with the cylinder profile	Contacting	Cable, 3-wire	2.5	543862	SME-8M-DS-24V-K-2,5-OE	
				5.0	543863	SME-8M-DS-24V-K-5,0-OE	
			Cable, 2-wire	2.5	543872	SME-8M-ZS-24V-K-2,5-OE	
				Plug M8x1, 3-pin	0.3	543861	SME-8M-DS-24V-K-0,3-M8D
	Insertable in the slot lengthwise, flush with the cylinder profile	Contacting	Cable, 3-wire	2.5	150855	SME-8-K-LED-24	
			Plug M8x1, 3-pin	0.3	150857	SME-8-S-LED-24	
N/C contact							
	Insertable in the slot lengthwise, flush with the cylinder profile	Contacting	Cable, 3-wire	7.5	160251	SME-8-O-K-LED-24	

Swivel/linear drive units DSL-B

Accessories



Ordering data – Connecting cables				Technical data → Internet: nebu	
	Electrical connection, left	Electrical connection, right	Cable length [m]	Part No.	Type
	Straight socket, M8x1, 3-pin	Cable, open end, 3-wire	2.5	541333	NEBU-M8G3-K-2.5-LE3
			5	541334	NEBU-M8G3-K-5-LE3
	Straight socket, M12x1, 5-pin	Cable, open end, 3-wire	2.5	541363	NEBU-M12G5-K-2.5-LE3
			5	541364	NEBU-M12G5-K-5-LE3
	Angled socket, M8x1, 3-pin	Cable, open end, 3-wire	2.5	541338	NEBU-M8W3-K-2.5-LE3
			5	541341	NEBU-M8W3-K-5-LE3
	Angled socket, M12x1, 5-pin	Cable, open end, 3-wire	2.5	541367	NEBU-M12W5-K-2.5-LE3
			5	541370	NEBU-M12W5-K-5-LE3

Ordering data – Slot covers for T-slot						
	For Ø	Application	Assembly	Length [m]	Part No.	Type
	16 ... 40	For sensor slots	Insertable from above	2x 0.5	151680	ABP-5-S
	16, 20	For profile slots	Insertable from above	2x 0.5	151681	ABP-5
	25 ... 40				151682	ABP-8

Swivel/linear drive units DSL-B

Accessories



Adapter kit
HAPB, HAVB, HMSV

Material:
Wrought aluminium alloy
Free of copper and PTFE
RoHS-compliant

 Note
The kit includes the individual mounting interface as well as the necessary mounting material.

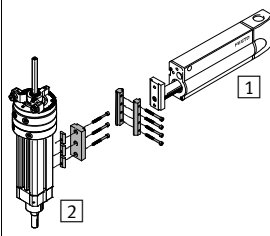
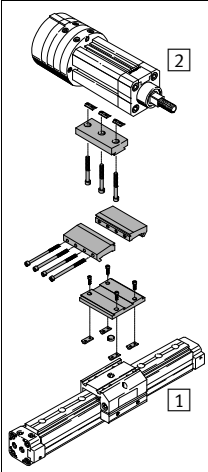
Permissible drive/drive combinations with adapter kit			Download CAD data → www.festo.com		
Combination	[1] Drive	[2] Drive	Adapter kit		
	Size	Size	CRC ¹⁾	Part No.	Type
HMP/DSL	HMP	DSL	HAPB, HMSV		
	16, 20, 25	16	2	177649	HMSV-3
				163214	HAPB-15
	20, 25	20		177649	HMSV-3
				163214	HAPB-15
	25	25		177649	HMSV-3
		163215	HAPB-16		
	32	20, 25, 32	177649	HMSV-3	
			163215	HAPB-16	
DGPL, DGE/DSL	DG...	DSL	HAPB, HAVB		
	25	16, 20	2	163214	HAPB-15
				163244	HAVB-8
				163202	HAPB-3
	25	25		163215	HAPB-16
				163244	HAVB-8
				163202	HAPB-3
	32 ²⁾	20		163214	HAPB-15
		163244	HAVB-8		
		163203	HAPB-4		
32 ²⁾	25, 32	163215	HAPB-16		
		163244	HAVB-8		
		163203	HAPB-4		
40	25, 32	163215	HAPB-16		
		163244	HAVB-5		
		163204	HAPB-5		

- 1) Corrosion resistance class CRC 2 to Festo standard FN 940070
Moderate corrosion stress. Indoor applications in which condensation may occur. External visible parts with primarily decorative requirements for the surface and which are in direct contact with the ambient atmosphere typical for industrial applications.
- 2) Only for DGPL

Product Range and Company Overview

A Complete Suite and Company Overview

Our experienced engineers provide complete support at every stage of your development process, including: conceptualization, analysis, engineering, design, assembly, documentation, validation, and production.



Custom Automation Components
Complete custom engineered solutions

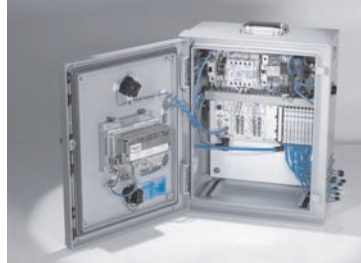

Custom Control Cabinets
Comprehensive engineering support and on-site services



Complete Systems
Shipment, stocking and storage services

The Broadest Range of Automation Components

With a comprehensive line of more than 30,000 automation components, Festo is capable of solving the most complex automation requirements.



Electromechanical
Electromechanical actuators, motors, controllers & drivers



Pneumatics
Pneumatic linear and rotary actuators, valves, and air supply



PLCs and I/O Devices
PLC's, operator interfaces, sensors and I/O devices

Supporting Advanced Automation... As No One Else Can!

Festo is a leading global manufacturer of pneumatic and electromechanical systems, components and controls for industrial automation, with more than 16,000 employees in 60 national headquarters serving more than 180 countries. For more than 80 years, Festo has continuously elevated the state of manufacturing with innovations and optimized motion control solutions that deliver higher performing, more profitable automated manufacturing and processing equipment. Our dedication to the advancement of automation extends beyond technology to the education and development of current and future automation and robotics designers with simulation tools, teaching programs, and on-site services.

Quality Assurance, ISO 9001 and ISO 14001 Certifications

Festo Corporation is committed to supply all Festo products and services that will meet or exceed our customers' requirements in product quality, delivery, customer service and satisfaction.

To meet this commitment, we strive to ensure a consistent, integrated, and systematic approach to management that will meet or exceed the requirements of the ISO 9001 standard for Quality Management and the ISO 14001 standard for Environmental Management.



© Copyright 2013, Festo Corporation. While every effort is made to ensure that all dimensions and specifications are correct, Festo cannot guarantee that publications are completely free of any error, in particular typing or printing errors. Accordingly, Festo cannot be held responsible for the same. For Liability and Warranty conditions, refer to our "Terms and Conditions of Sale", available from your local Festo office. All rights reserved. No part of this publication may be reproduced, distributed, or transmitted in any form or by any means, electronic, mechanical, photocopying or otherwise, without the prior written permission of Festo. All technical data subject to change according to technical update.



Printed on recycled paper at New Horizon Graphic, Inc., FSC certified as an environmental friendly printing plant.

Festo North America



**1 Festo Canada
Headquarters
Festo Inc.**
5300 Explorer Drive
Mississauga, ON
L4W 5G4

2 Montréal
5600, Trans-Canada
Pointe-Claire, QC
H9R 1B6

3 Québec City
2930, rue Watt#117
Québec, QC
G1X 4G3



**4 Festo United States
Headquarters
Festo Corporation**
395 Moreland Road
Hauppauge, NY
11788

5 Appleton
North 922 Tower View Drive, Suite N
Greenville, WI
54942

7 Detroit
1441 West Long Lake Road
Troy, MI
48098

6 Chicago
85 W Algonquin - Suite 340
Arlington Heights, IL
60005

8 Silicon Valley
4935 Southfront Road, Suite F
Livermore, CA
94550

Festo Regional Contact Center

Canadian Customers

Commercial Support:
Tel: 1 877 GO FESTO (1 877 463 3786)
Fax: 1 877 FX FESTO (1 877 393 3786)
Email: festo.canada@ca.festo.com

Technical Support:
Tel: 1 866 GO FESTO (1 866 463 3786)
Fax: 1 877 FX FESTO (1 877 393 3786)
Email: technical.support@ca.festo.com

USA Customers

Commercial Support:
Tel: 1 800 99 FESTO (1 800 993 3786)
Fax: 1 800 96 FESTO (1 800 963 3786)
Email: customer.service@us.festo.com

Technical Support:
Tel: 1 866 GO FESTO (1 866 463 3786)
Fax: 1 800 96 FESTO (1 800 963 3786)
Email: product.support@us.festo.com