

Standard cylinders DNG/DNGZS, ISO 15552



- 1 - Type discontinued
Available up until 2016

Standard cylinders DNG/DNGZS, ISO 15552

Features

FESTO

Brief description

- Double-acting
- For contactless position sensing
- With adjustable end-position cushioning at both ends
- Robust tie rod design
- Standards-based cylinders to ISO 15552 (corresponds to the withdrawn standards ISO 6431, DIN ISO 6431, VDMA 24 562, NF E 49 003.1 and UNI 10290)



DIN

VDMA

DNG

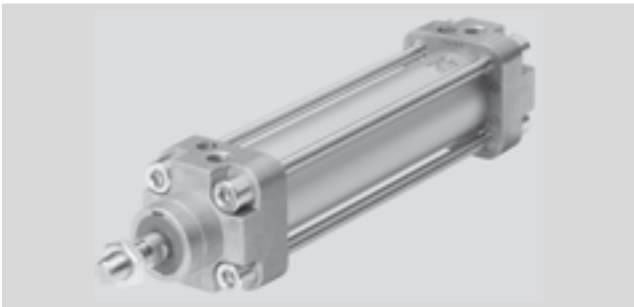

DNGZS with central trunnion mounting (fixed)

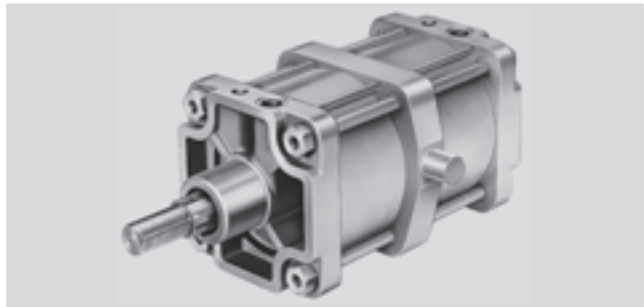

Mounting options

Installation of basic version

Mounting at front

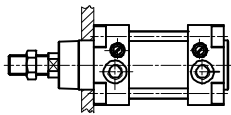

Mounting at rear

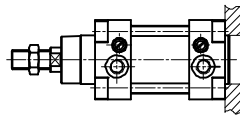

Installation options using mounting attachments

Foot mounting MS1¹⁾

HNG

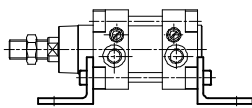

Flange mounting MF1/MF2¹⁾

FNG

at front at rear

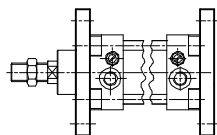

Swivel flange MP2¹⁾

SNG/SNGB/SNGL

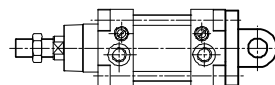

1) Standard designation to ISO 15552 (ISO 6431)

Standard cylinders DNG/DNGZK/DNGZS, ISO 15552

Peripherals overview

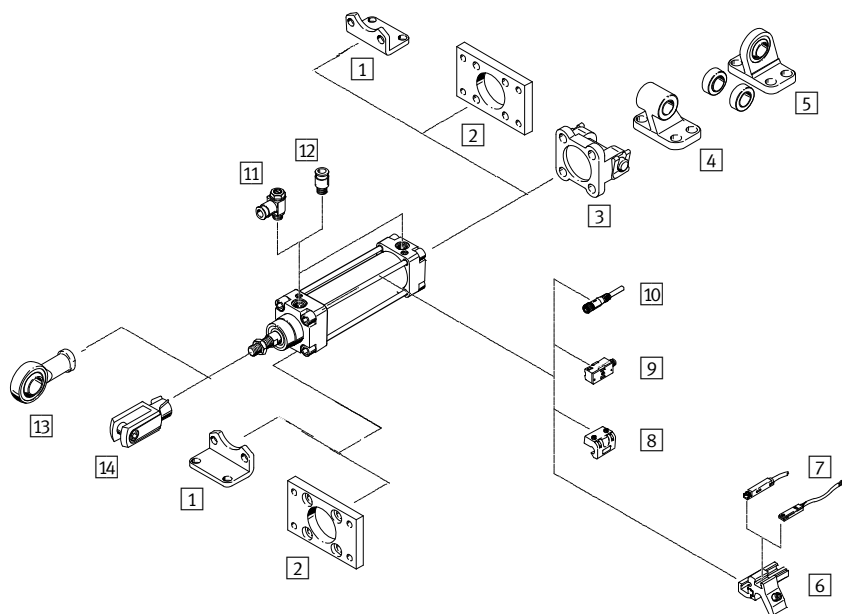

Mounting attachments and accessories			
	Brief description	→ Page/Internet	
1	Foot mounting HNG	For bearing and end caps corresponds to MS1 to ISO 15552	LEERER MERKER
2	Flange mounting FNG	For bearing or end caps corresponds to MF1/MF2 to ISO 15552	LEERER MERKER
3	Swivel flange SNGB	For end caps corresponds to MP2 to ISO 15552	LEERER MERKER
4	Clevis foot mounting LN	For swivel flange SNGB	12
5	Clevis foot mounting LSN	With spherical bearing	12
6	Sensor mounting kit SMBZ-8- ...	For proximity sensor SME/SMT-8	13
7	Proximity sensors SME/SMT-8	-	13
8	Sensor mounting kit SMB-1	For proximity sensor SMEO-1/SMTO-1	14
9	Proximity sensors SMEO-1/SMTO-1	-	14
10	Connecting cable, straight NEBU	-	13
	Connecting cable, angled NEBU	-	13
11	One-way flow control valve GRLA	For speed regulation	grla
12	Push-in fitting QS	For connecting compressed air tubing with standard O.D.	quick star
13	Rod eye SGS	With spherical bearing	12
14	Rod clevis SG	Permits a swivelling movement of the cylinder in one plane	12

- 1 - Type discontinued
Available up until 2016

FESTO

Standard cylinders DNG/DNGZS, ISO 15552

Type codes

		DNG	-	250	-	80	-	PPV	-	A	-		-	
Type														
Double-acting														
DNG	Standard cylinder													
DNGZS	Standard cylinder with central trunnion mounting (fixed)													
Piston Ø [mm]														
Stroke [mm]														
Cushioning														
PPV	Adjustable at both ends													
Position sensing														
A	For proximity sensing													
Trunnion flange axis distance														
XV	Trunnion flange position													
Variants														
S2	Through piston rod													
S3	Stainless steel piston rod													
S6	Heat resistant seal for temperatures up to 120 °C													
S8	High corrosion protection													

- 2 - Type discontinued
Available up until 2016

FESTO

Standard cylinders DNG/DNGZS, ISO 15552

Technical data

Function

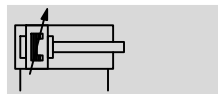

- \varnothing - Diameter
250 ... 320 mm
- | - Stroke length
10 ... 2000 mm

- Standards-based cylinders to ISO 15552 (corresponds to the withdrawn standards ISO 6431, DIN ISO 6431, VDMA 24 562, NF E 49 003.1 and UNI 10290)



DIN

VDMA

Variants

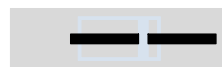

www.festo.com

S2

S3

S6

S8

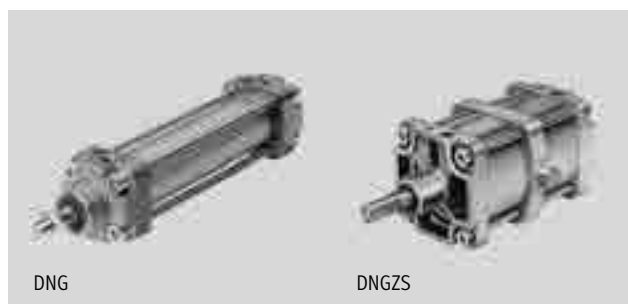

DNG

DNGZS

General technical data

Piston \varnothing	250	320
Pneumatic connection	G1	G1
Piston rod thread	M42x2	M48x2
Operating medium	Compressed air in accordance with ISO 8573-1:2010 [7:4:4]	
Note on operating/pilot medium	Operation with lubricated medium possible (in which case lubricated operation will always be required)	
Design	Piston	
	Piston rod	
	Profile barrel	
Cushioning	Adjustable at both ends	
Cushioning length [mm]	60	66
Position sensing	For proximity sensing	
Type of mounting	Via accessories	
Mounting position	Any	

Operating and environmental conditions

Operating pressure [bar]	0.6 ... 10
Ambient temperature ¹⁾ [°C]	-20 ... +80

1) Note operating range of proximity sensors

Forces [N]

Piston \varnothing	250	320
Theoretical force at 6 bar, advancing	29,450	48,250
Theoretical force at 6 bar, retracting	28,270	46,380

- 1 - Type discontinued
Available up until 2016

Standard cylinders DNG/DNGZS, ISO 15552

Technical data

FESTO

Lateral force F_Q as a function of the stroke length l

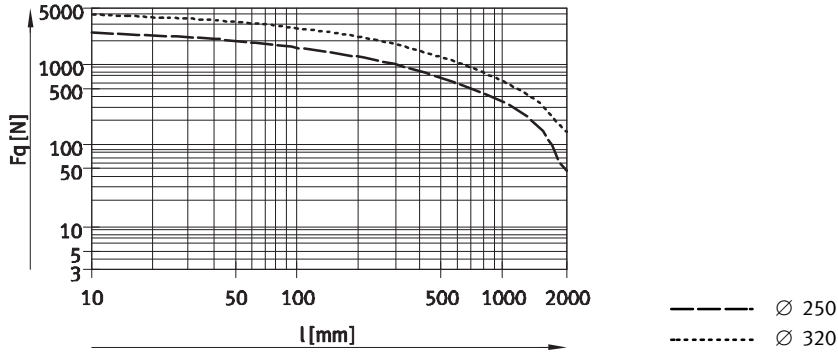

Weights [g]

Piston Ø	250	320
Product weight at 0 mm stroke	30,800	53,200
Additional weight per 10 mm stroke	360	570

Materials

Sectional view DNG

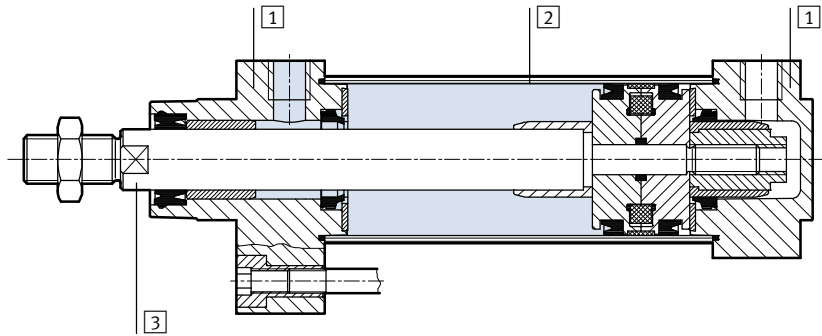

Standard cylinder	
1	Bearing and end caps Aluminium
2	Cylinder barrel High-alloy steel
3	Piston rod, tie rod High-alloy steel
-	Seals NBR, TPE-U (PU)

- Type discontinued
Available up until 2016

Standard cylinders DNG/DNGZS, ISO 15552

Technical data

FESTO

Dimensions

Download CAD data → www.festo.com

DNG

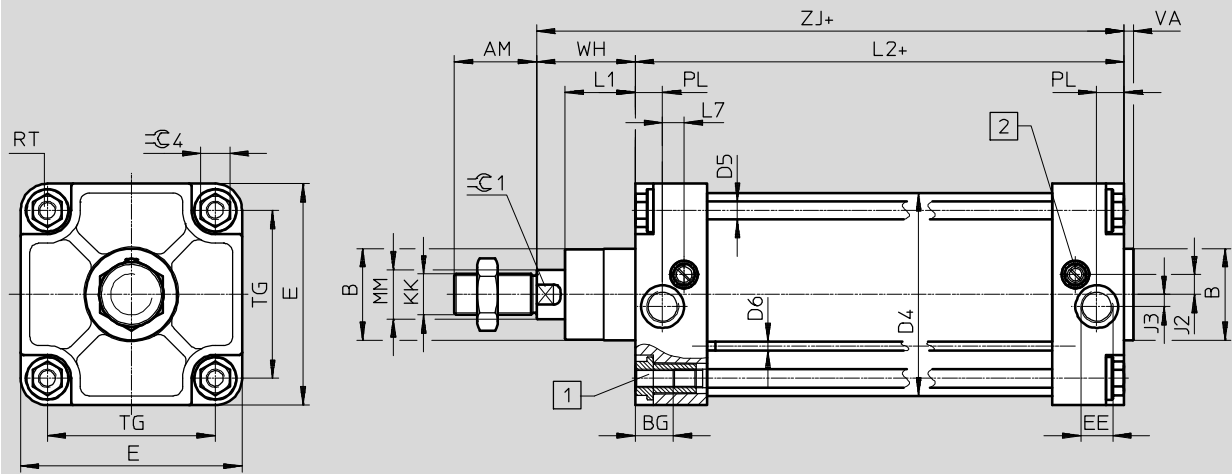

- 1 Socket head screw with female thread for mounting attachments
- 2 Regulating screw for adjustable end-position cushioning

+ = plus stroke length

Variant S2 – Through piston rod

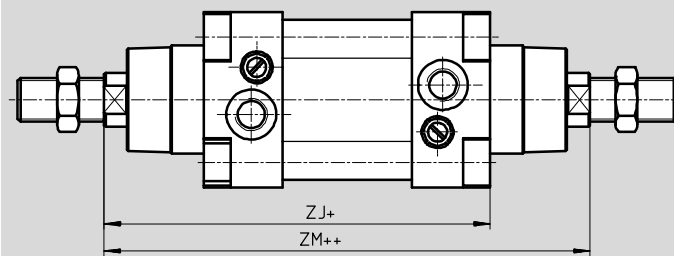

+ = plus stroke length

++ = plus 2x stroke length

∅	AM	B	BG	D4	D5	D6	E	EE	J2	J3	KK	L1
[mm]		∅ d11		∅	∅							
250	84	90	25.5	254	18.3 ... 20	6	270	G1	25	25	M42x2	67
320	96	110	28.5	325	22 ... 25	6	340	G1	30	30	M48x2	82

∅	L2	L7	MM	PL	RT	TG	VA	WH	ZJ	ZM	∅C1	∅C4
[mm]			∅									
250	200 ±2	0	50	31	M20	220	10	105	305	410	46	36
320	220 ±2	0	63	31	M24	270	10	120	340	460	55	46

-  - Type discontinued
Available up until 2016

Standard cylinders DNG/DNGZS, ISO 15552

Technical data

FESTO

Dimensions

Download CAD data → www.festo.com

DNGZS – with central trunnion mounting, fixed

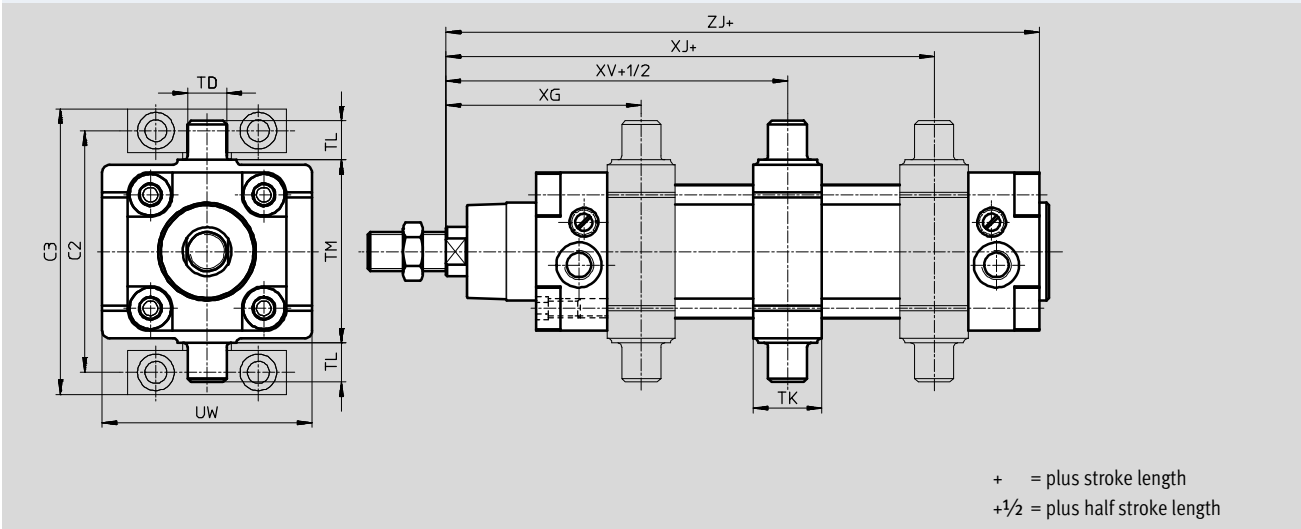

∅	C2	C3	TD	TK	TL	TM
[mm]			∅ e9			
250	375	420	40	60	40	320
320	465	520	50	70	50	400

∅	UW	XG	XJ	XV	ZJ
[mm]					
250	270	187	223	205	305
320	340	211	249	230	340

-  - Note

DNGZS-...-PPV-A:

The central trunnion mounting is fitted as standard tightly screwed with the tie rods in the cylinder mid-section. As a special design,

mounting is possible between the dimensions XG and XJ. The required dimension XV must be entered in the order (→ 10).

 Type discontinued
Available up until 2016

Standard cylinders DNG/DNGZS, ISO 15552

FESTO

Technical data

Ordering data					
Design	Stroke [mm]	Piston Ø 250 [mm]		Piston Ø 320 [mm]	
		Part No.	Type ¹⁾	Part No.	Type ¹⁾
Basic version					
Variable stroke	1 ... ,2,000 ²⁾	151892	DNG-250-...-PPV-A	151897	DNG-320-...-PPV-A
Variant S2	1 ... 2,000 ²⁾	151893	DNG-250-...-PPV-A-S2	151898	DNG-320-...-PPV-A-S2
Variant S3	1 ... 2,000 ²⁾	151894	DNG-250-...-PPV-A-S3	151899	DNG-320-...-PPV-A-S3
Variant S6	1 ... 2,000 ²⁾	151895	DNG-250-...-PPV-A-S6	151900	DNG-320-...-PPV-A-S6
Variant S8	1 ... 2,000 ²⁾	151896	DNG-250-...-PPV-A-S8	151901	DNG-320-...-PPV-A-S8
With fixed central trunnion mounting					
Variable stroke	10 ... 1,100	→ 10			

1) The scope of delivery includes a hex nut for the piston rod thread.

2) Cylinders with position sensing require a minimum stroke of 10 mm to ensure reliable sensing

- 1 - Type discontinued
Available up until 2016

Standard cylinders DNG/DNGZS, to ISO 15552

FESTO

Ordering data – Modular product DNGZS

M Mandatory data						O Options		
Module No.	Function	Piston Ø	Stroke	Cushioning	Position sensing	Trunnion flange position	Temperature-resistant	Corrosion protection
157500 157504	DNGZS	250 320	10 ... 1 100	PPV	A	...XV	S6	S3 S8
Ordering example								
157504	DNGZS	- 320	- 600	- PPV	- A	- 215XV	- S6	- S3

Ordering table						
Size	250	320	Condi- tions	Code	Enter code	
M Module No.	157500	157504				
Function	Standard cylinder, double-acting, with central trunnion mounting to ISO 15552			DNGZS		DNGZS
Piston Ø [mm]	250	320		-...		
Stroke [mm]	10 ... 1 100			-...		
Cushioning	Pneumatic cushioning adjustable at both ends			-PPV		-PPV
Position sensing	For proximity sensing			-A		-A
O Trunnion flange position [mm]	187 ... 1 323	211 ... 1 349	1	-...XV		
Temperature-resistant	Heat-resistant seals up to max. 120 °C			-S6		
Corrosion protection	Stainless steel piston rod			- S3		
	High corrosion protection including piston rod, stainless steel		2	-S8		

1 ...XV Trunnion flange at standard mid-position of cylinder:
Piston Ø 250 mm: $205 \text{ mm} + \frac{\text{Stroke}}{2}$
Piston Ø 320 mm: $230 \text{ mm} + \frac{\text{Stroke}}{2}$

2 S8 Not with S6.

Transfer order code

	DNGZS	-		-		-	PPV	-	A	-		-		-	
--	--------------	---	--	---	--	---	------------	---	----------	---	--	---	--	---	--

- Type discontinued
Available up until 2016

FESTO

Standard cylinders DNG/DNGZS, ISO 15552

Accessories

Foot mounting HNG

Material:
 Galvanised steel
 Free of copper and PTFE

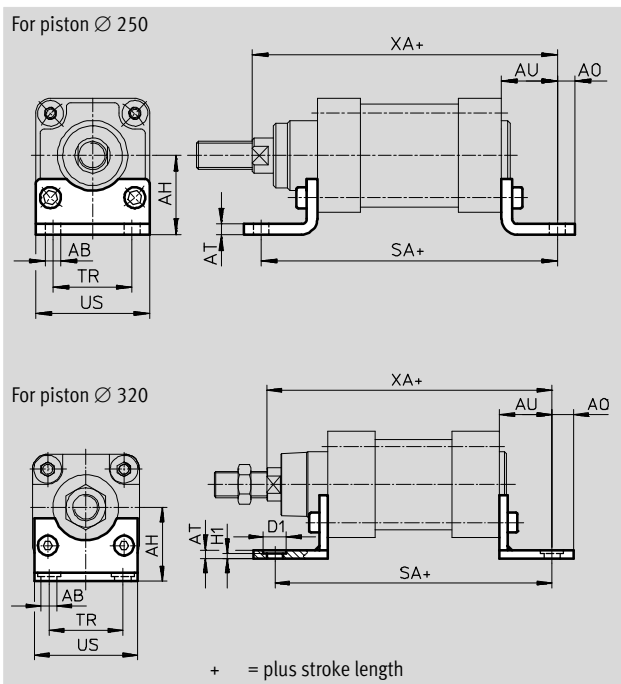

Dimensions and ordering data															
For \varnothing [mm]	AB \varnothing H14	AH	AO	AT	AU	D1	H1	SA	TR	US	XA	CRC ¹⁾	Weight [g]	Part No.	Type
250	28	165	35	20	75	-	-	350	165	270	380	2	8,000	157510	HNG-250
320	35	200	40	25	85	60	23	390	200	340	425	2	13,000	157511	HNG-320

1) Corrosion resistance class 2 according to Festo standard 940 070
 Components requiring moderate corrosion resistance. Externally visible parts with primarily decorative surface requirements which are in direct contact with a surrounding industrial atmosphere or media such as cooling or lubricating agents

Flange mounting FNG

Material:
 Painted nodular graphite cast iron
 Free of copper and PTFE

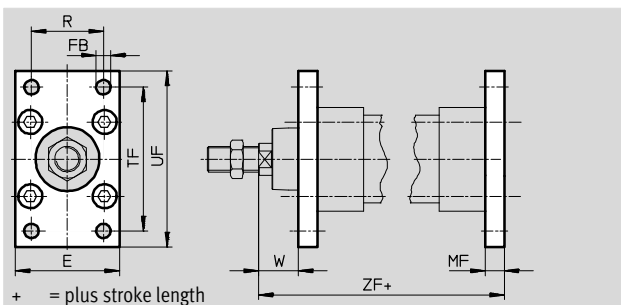
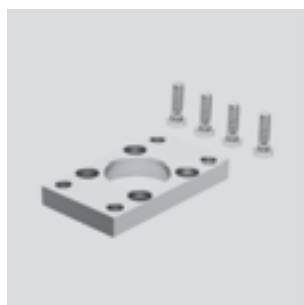

Dimensions and ordering data												
For \varnothing [mm]	E	FB \varnothing	MF	R	TF	UF	W	ZF	CRC ¹⁾	Weight [g]	Part No.	Type
250	270	26	25	165	330	390	80	330	1	8,657	157508	FNG-250
320	340	33	30	200	400	470	90	370	1	15,109	157509	FNG-320

1) Corrosion resistance class 1 according to Festo standard 940 070
 Components with light corrosion exposure. Protection for transport and storage. Components without significant decorative function or surface, e.g. installed out of sight internally or behind covers.

- 1 - Type discontinued
Available up until 2016

Standard cylinders DNG/DNGZS, ISO 15552

Accessories

FESTO

Swivel flange SNGB
for clevis foot LN/LSN

Material:
Die-cast aluminium

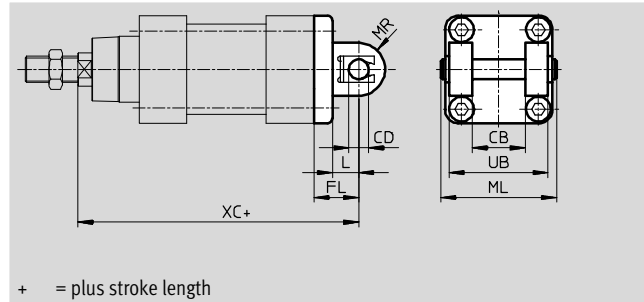

Dimensions and ordering data

For \varnothing	CB \varnothing	CD \varnothing	FL	L	ML	MR	UB	XC	CRC ¹⁾	Weight [g]	Part No.	Type
[mm]							h14					
250	110	40	70	47	231	40	200	375	2	15 200	157512	SNGB-250
320	120	45	80	52	253	45	220	420	2	26 450	157513	SNGB-320

1) Corrosion resistance class 2 according to Festo standard 940 070

Components requiring moderate corrosion resistance. Externally visible parts with primarily decorative surface requirements which are in direct contact with a surrounding industrial atmosphere or media such as cooling or lubricating agents

Ordering data – Mounting attachments

Designation	For \varnothing	Part No.	Type
Clevis foot LN			
	250	9039	LN-250
	320	9040	LN-320
Clevis foot LSN			
	250	6990	LSN-250
	320	6991	LSN-320

Ordering data – Piston rod attachments



Designation	For \varnothing	Part No.	Type
Rod eye SGS			
	250	10776	SGS-M42x2
	320	10777	SGS-M48x2
Rod clevis SG			
	250	9582	SG-M42x2
	320	9583	SG-M48x2



 Type discontinued
Available up until 2016



Standard cylinders DNG/DNGZS, ISO 15552

Accessories

FESTO

Ordering data – Proximity sensors for T-slot, magneto-resistive						Technical data → Internet: smt	
	Type of mounting	Switch output	Electrical connection	Cable length [m]	Part No.	Type	
N/O contact							
	Insertable in the slot from above, flush with cylinder profile, short design	PNP	Cable, 3-wire	2.5	574335	SMT-8M-A-PS-24V-E-2,5-OE	
			Plug M8x1, 3-pin	0.3	574334	SMT-8M-A-PS-24V-E-0,3-M8D	
			Plug M12x1, 3-pin	0.3	574337	SMT-8M-A-PS-24V-E-0,3-M12	
		NPN	Cable, 3-wire	2.5	574338	SMT-8M-A-NS-24V-E-2,5-OE	
			Plug M8x1, 3-pin	0.3	574339	SMT-8M-A-NS-24V-E-0,3-M8D	
N/C contact							
	Insertable in the slot from above, flush with cylinder profile, short design	PNP	Cable, 3-wire	7.5	574340	SMT-8M-A-PO-24V-E-7,5-OE	

Ordering data – Proximity sensors for T-slot, magnetic reed						Technical data → Internet: sme	
	Type of mounting	Switch output	Electrical connection	Cable length [m]	Part No.	Type	
N/O contact							
	Insertable in the slot from above, flush with cylinder profile	Contacting	Cable, 3-wire	2.5	543862	SME-8M-DS-24V-K-2,5-OE	
				5.0	543863	SME-8M-DS-24V-K-5,0-OE	
			Cable, 2-wire	2.5	543872	SME-8M-ZS-24V-K-2,5-OE	
				Plug M8x1, 3-pin	0.3	543861	SME-8M-DS-24V-K-0,3-M8D
	Insertable in the slot lengthwise, flush with the cylinder profile	Contacting	Cable, 3-wire	2.5	150855	SME-8-K-LED-24	
			Plug M8x1, 3-pin	0.3	150857	SME-8-S-LED-24	
N/C contact							
	Insertable in the slot lengthwise, flush with the cylinder profile	Contacting	Cable, 3-wire	7.5	160251	SME-8-O-K-LED-24	

Ordering data – Connecting cables					Technical data → Internet: nebu	
	Electrical connection, left	Electrical connection, right	Cable length [m]	Part No.	Type	
	Straight socket, M8x1, 3-pin	Cable, open end, 3-wire	2.5	541333	NEBU-M8G3-K-2.5-LE3	
			5	541334	NEBU-M8G3-K-5-LE3	
	Angled socket, M8x1, 3-pin	Cable, open end, 3-wire	2.5	541338	NEBU-M8W3-K-2.5-LE3	
			5	541341	NEBU-M8W3-K-5-LE3	

Ordering data – Mounting kits for proximity sensors SME/SMT-8				Technical data → Internet: smbz	
	For Ø	Materials	Part No.	Type	
	250, 320 mm	Rail: Wrought aluminium alloy, anodised Screws: High-alloy steel Free of copper and PTFE	537808	SMBZ-8-125/320	

- I - Type discontinued
Available up until 2016

Standard cylinders DNG/DNGZS, ISO 15552

Accessories

FESTO

Ordering data – Rectangular proximity sensors, magneto-resistive						Technical data → Internet: smto	
	Mounting	Switch output	Electrical connection		Cable length [m]	Part No.	Type
			Cables	M8 plug			
NO contact							
	Via accessories	PNP	3-wire	–	2.5	151683	SMT0-1-PS-K-LED-24-C
			–	3-pin	–	151685	SMT0-1-PS-S-LED-24-C
		NPN	3-wire	–	2.5	151684	SMT0-1-NS-K-LED-24-C
			–	3-pin	–	151686	SMT0-1-NS-S-LED-24-C

Ordering data – Rectangular proximity sensors, magnetic reed						Technical data → Internet: smeo	
	Mounting	Electrical connection		Cable length [m]	Part No.	Type	
		Cables	M8 plug				
NO contact							
	Via accessories	3-wire	–	2.5	30459	SME0-1-LED-24-B	
		3-wire	–	5.0	151672	SME0-1-LED-24-K5-B	
		–	3-pin	–	150848	SME0-1-S-LED-24-B	

Ordering data – Mounting kits for proximity sensors SME0/SMT0-1				Technical data → Internet: smb	
	For Ø	Mounting		Part No.	Type
	250, 320 mm	Directly on the mounting or tie rod		11886	SMB-1

Product Range and Company Overview

A Complete Suite and Company Overview

Our experienced engineers provide complete support at every stage of your development process, including: conceptualization, analysis, engineering, design, assembly, documentation, validation, and production.

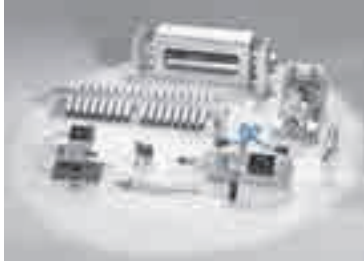

Custom Automation Components
Complete custom engineered solutions



Custom Control Cabinets
Comprehensive engineering support and on-site services



Complete Systems
Shipment, stocking and storage services

The Broadest Range of Automation Components

With a comprehensive line of more than 30,000 automation components, Festo is capable of solving the most complex automation requirements.



Electromechanical
Electromechanical actuators, motors, controllers & drivers



Pneumatics
Pneumatic linear and rotary actuators, valves, and air supply



PLCs and I/O Devices
PLC's, operator interfaces, sensors and I/O devices

Supporting Advanced Automation... As No One Else Can!

Festo is a leading global manufacturer of pneumatic and electromechanical systems, components and controls for industrial automation, with more than 16,000 employees in 60 national headquarters serving more than 180 countries. For more than 80 years, Festo has continuously elevated the state of manufacturing with innovations and optimized motion control solutions that deliver higher performing, more profitable automated manufacturing and processing equipment. Our dedication to the advancement of automation extends beyond technology to the education and development of current and future automation and robotics designers with simulation tools, teaching programs, and on-site services.

Quality Assurance, ISO 9001 and ISO 14001 Certifications

Festo Corporation is committed to supply all Festo products and services that will meet or exceed our customers' requirements in product quality, delivery, customer service and satisfaction.

To meet this commitment, we strive to ensure a consistent, integrated, and systematic approach to management that will meet or exceed the requirements of the ISO 9001 standard for Quality Management and the ISO 14001 standard for Environmental Management.



© Copyright 2013, Festo Corporation. While every effort is made to ensure that all dimensions and specifications are correct, Festo cannot guarantee that publications are completely free of any error, in particular typing or printing errors. Accordingly, Festo cannot be held responsible for the same. For Liability and Warranty conditions, refer to our "Terms and Conditions of Sale", available from your local Festo office. All rights reserved. No part of this publication may be reproduced, distributed, or transmitted in any form or by any means, electronic, mechanical, photocopying or otherwise, without the prior written permission of Festo. All technical data subject to change according to technical update.



Printed on recycled paper at New Horizon Graphic, Inc., FSC certified as an environmental friendly printing plant.

Festo North America

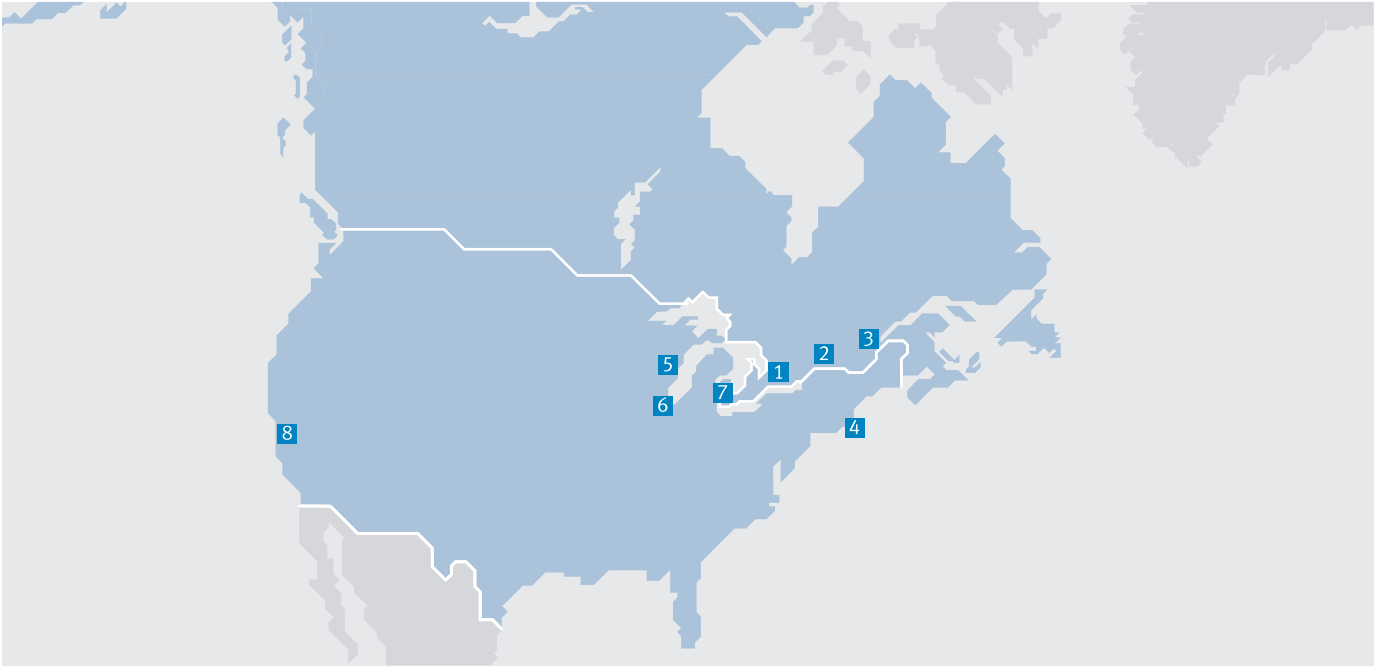

**1 Festo Canada
Headquarters
Festo Inc.**
5300 Explorer Drive
Mississauga, ON
L4W 5G4

2 Montréal
5600, Trans-Canada
Pointe-Claire, QC
H9R 1B6

3 Québec City
2930, rue Watt#117
Québec, QC
G1X 4G3



**4 Festo United States
Headquarters
Festo Corporation**
395 Moreland Road
Hauppauge, NY
11788

5 Appleton
North 922 Tower View Drive, Suite N
Greenville, WI
54942

7 Detroit
1441 West Long Lake Road
Troy, MI
48098

6 Chicago
85 W Algonquin - Suite 340
Arlington Heights, IL
60005

8 Silicon Valley
4935 Southfront Road, Suite F
Livermore, CA
94550

Festo Regional Contact Center

Canadian Customers

Commercial Support:
Tel: 1 877 GO FESTO (1 877 463 3786)
Fax: 1 877 FX FESTO (1 877 393 3786)
Email: festo.canada@ca.festo.com

Technical Support:
Tel: 1 866 GO FESTO (1 866 463 3786)
Fax: 1 877 FX FESTO (1 877 393 3786)
Email: technical.support@ca.festo.com

USA Customers

Commercial Support:
Tel: 1 800 99 FESTO (1 800 993 3786)
Fax: 1 800 96 FESTO (1 800 963 3786)
Email: customer.service@us.festo.com

Technical Support:
Tel: 1 866 GO FESTO (1 866 463 3786)
Fax: 1 800 96 FESTO (1 800 963 3786)
Email: product.support@us.festo.com