

Cantilever axes DGEA, with toothed belt drive



Cantilever axes DGEA, with toothed belt drive

Features

Key features at a glance

- Super flat Ω drive head enabling high mechanical torques.
- Improved dynamics compared to toothed belt axis DGE-ZR in cantilever operation, as the motor, gear unit and drive head are securely mounted and thus the moving load (profile barrel) is considerably reduced.
- Tried and tested motor-controller packages can be utilised.
- Mounting options adapted to the new multi-axis modular system.



Size		18	25	40
Max. working stroke	[mm]	800	900	1000
Max. working load	[kg]	7	18	27
Max. speed	[m/s]	3	3	3
Max. feed force	[N]	230	400	1000

- High-quality guide as for DGE-KF/DGP-KF axis.

Variants

Basic design

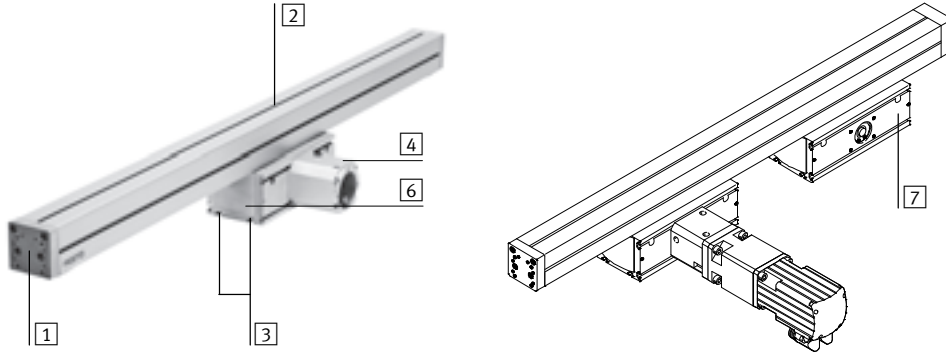

- 1 Mounting interface for working load: thread, centring holes and hole pattern are identical to the end caps on the DGE axes. Both caps can be machined as desired or removed and replaced by others.

- 2 Profile barrel: 3 sides with slots for external mounting – clearance for tubing and electrical cable throughfeed

- 3 Mounting interface for cantilever application (matched to DGE-...-KF slide)

- 4 Coupling housing

- 5 Coupling housing with integrated angled gear unit

- 6 Drive head

- 7 Optional: Additional drive head without drive shaft for increasing mechanical torque resistance

With angled gear unit

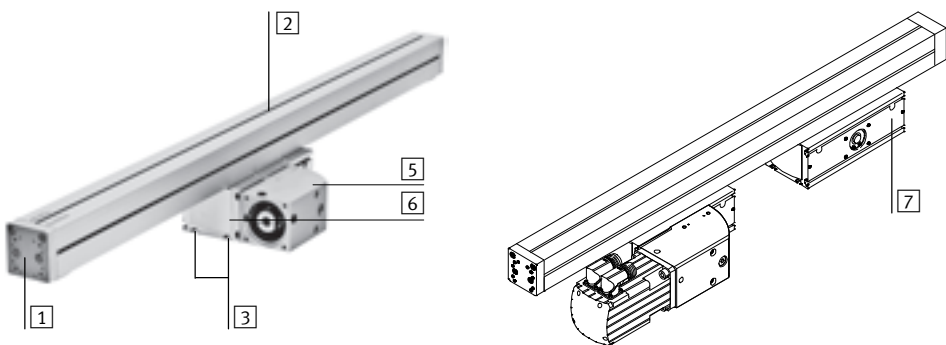

Cantilever axes DGEA, with toothed belt drive

Features

System selection for electromechanical drives

Cantilever axis



-  - Note

For the cantilever axes and the motors there are matching complete solutions.

Motor kit

→ 22

Axial kit



Axial kit consisting of:

- Motor flange
- Coupling housing
- Coupling
- Screws

Motor

→ 22

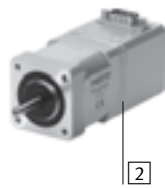

- 1 Servo motor EMME-AS, EMMS-AS
- 2 Stepper motor EMMS-ST

Motor controller

Technical data → Internet: motor controller



- 1 Servo motor controller CMMP-AS
- 2 Stepper motor controller CMMS-ST

Cantilever axes DGEA, with toothed belt drive

System example

System product for handling and assembly technology

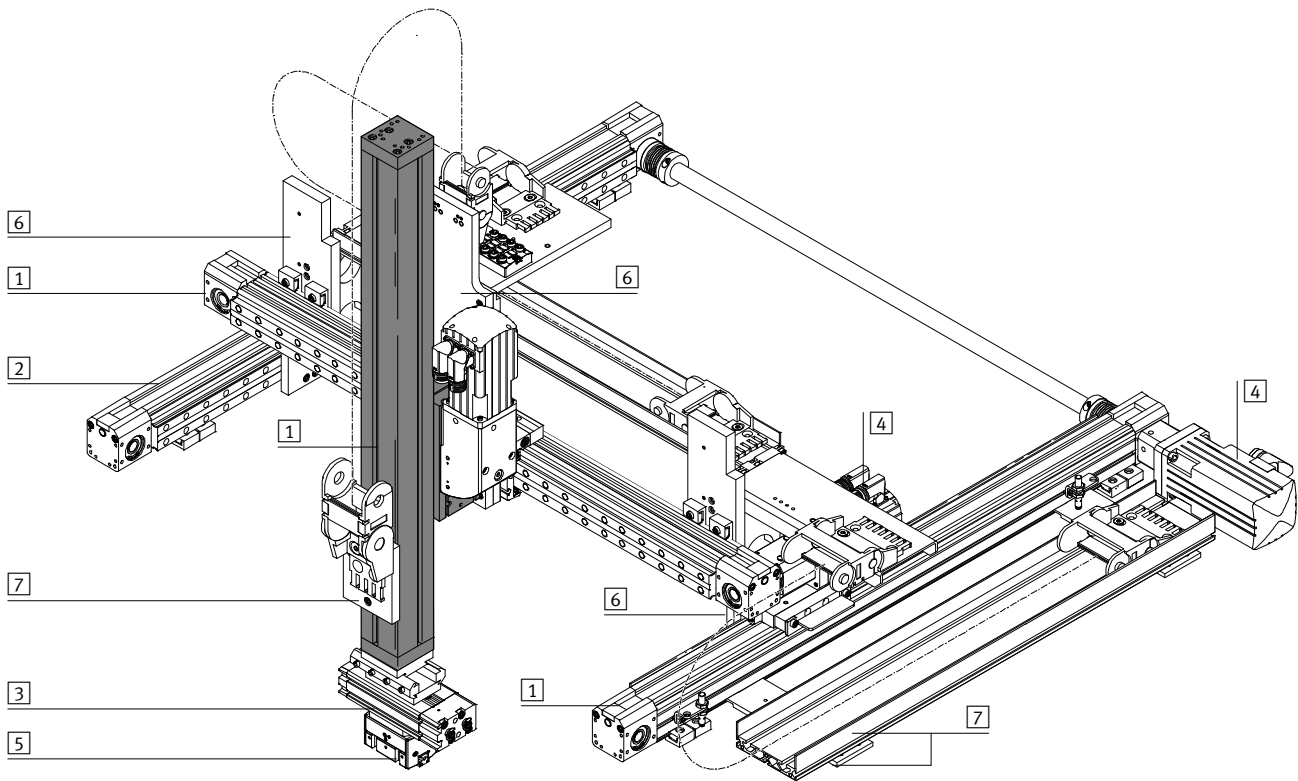

System elements and accessories		
	Description	→ Page/Internet
1	Axes	Wide range of combination options within handling and assembly technology axes
2	Passive guide axis	To increase force and torque capacity in multi-axis applications guide axes
3	Drive units	Wide range of combination options within handling and assembly technology drive
4	Motors	Servo and stepper motors, with or without gearing motor
5	Grippers	Wide range of variation options within handling and assembly technology gripper
6	Adapters	For drive/drive combinations 29
		For drive/gripper combinations gripper
7	Installation components	For achieving a clear-cut, safe layout for electrical cables and tubing installation component

Cantilever axes DGEA, with toothed belt drive

Type codes

DGEA - 25 - 500 - ZR - WH - ZWK -

Type

DGEA	Cantilever axis
------	-----------------

Size

Stroke [mm]

Drive function

ZR	Toothed belt
----	--------------

Drive head

WH	Drive shaft at rear
WV	Drive shaft at front
WB	Drive shaft at both ends
GVL	Integrated angled gear unit/motor at front left
GVR	Integrated angled gear unit/motor at front right
GHL	Integrated angled gear unit/motor at rear left
GHR	Integrated angled gear unit/motor at rear right

Additional drive head

ZWK	Without drive shaft
-----	---------------------

Accessories supplied separately

...S	Slot cover for profile slot
...B	Slot cover for drive head
...Y	Slot nut for profile slot
...X	Slot nut for drive head
...C	Shock absorber with retainer
...Z	Centring sleeve
L	Mounting kit for proximity sensor
...O	Proximity sensor with cable (normally open contact)
...P	Proximity sensor with cable (normally closed contact)
...W	Proximity sensor with plug (normally open contact)
...R	Proximity sensor with plug (normally closed contact)
...V	Cable with socket, 2.5 m

Cantilever axes DGEA, with toothed belt drive

Peripherals overview

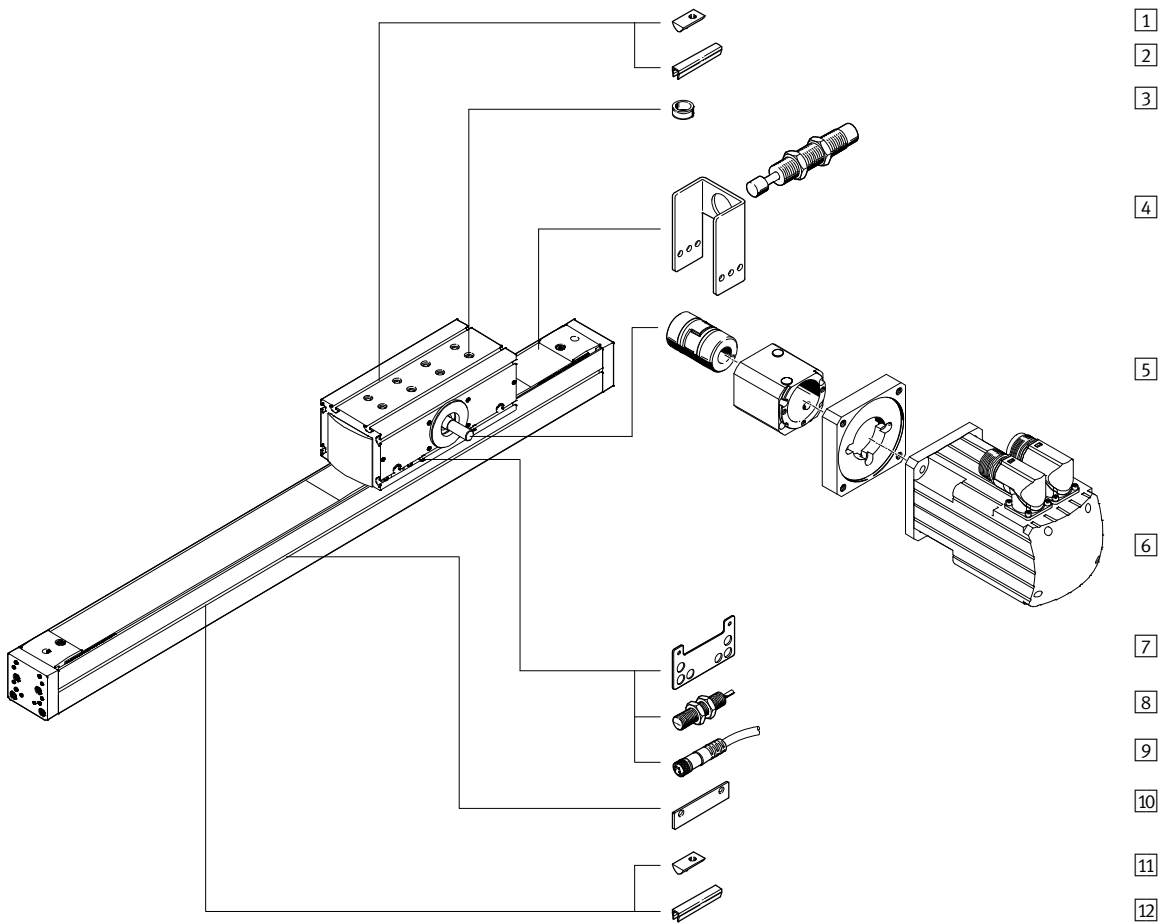

With angled gear unit

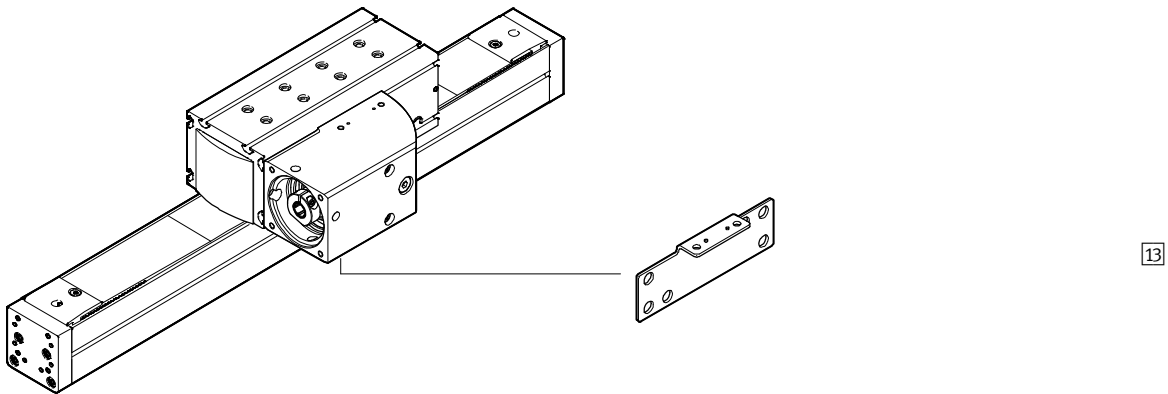

Cantilever axes DGEA, with toothed belt drive

Peripherals overview

Variants and accessories				
Type	Brief description	Basic design	Angled gear unit	→ Page/Internet
1 Slot nut for drive head X	For mounting the axis	■	■	28
2 Slot cover for drive head B	For protecting against ingress of dirt	■	■	28
3 Centring sleeve Z	To centre the axis	■	■	28
4 Shock absorber with retainer C	Prevents damage to the axis in the event of a power failure (in vertical operation), if the axis is driven into the end position by the load	■	■	27
5 Axial kit EAMM-A	For axial motor attachment (consisting of: coupling housing, clamping component, motor flange)	■	-	22
5 Coupling housing KG	Adapter for mounting the motor on the axis	■	integrated	22
5 Coupling KSE	Connecting element between axis and motor	■	integrated	22
5 Motor flange EAMF	Connecting element between coupling housing and motor	■	integrated	22
6 Motor EMMS	Motors specially matched to the axis, with or without gearing	■	■	22
7 Mounting plate L	Adapter for mounting the SIEN proximity sensor on the axis (basic design)	■	-	25
8 Proximity sensor O/P/W/R	For providing a proximity signal or safety check	■	■	28
9 Cable with socket V	Via proximity sensor	■	■	28
10 Switching lug L	For sensing the slide position	■	■	25
11 Slot nut for profile slot Y	For mounting attachments	■	■	28
12 Slot cover for profile slot S	For protecting against ingress of dirt	■	■	28
13 Mounting plate L	Adapter for mounting the SIEN proximity sensor on the axis with angled gear unit	-	■	26

Cantilever axes DGEA, with toothed belt drive

FESTO

Technical data

Function

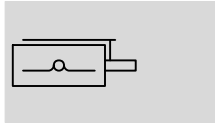

- - Size
18, 25, 40
- - Stroke length
100 ... 1000 mm



General technical data				
Size		18	25	40
Constructional design		Cantilever axis with toothed belt drive		
Guide		Recirculating ball bearing guide		
Mounting position		Any		
Max. working stroke ¹⁾	[mm]	1 ... 800	1 ... 900	1 ... 1000
Max. working (effective) load, horizontal ²⁾	[kg]	6	15	40
Max. working load, vertical	[kg]	10	20	50
Max. feed force F_x	[N]	230	400	1000
Max. speed	[m/s]	3		
Max. acceleration ³⁾	[m/s ²]	50		
Repetition accuracy	[mm]	< ±0.05		
Basic design				
Max. driving torque	[Nm]	3	5.2	19
Max. no-load driving torque ⁴⁾	[Nm]	0.4	0.4	1
Maximum drive speed	[rpm]	2222	2222	1500
With angled gear unit				
Max. driving torque	[Nm]	1.4	2.2	7.3
Max. no-load driving torque ⁴⁾	[Nm]	0.3	0.6	1.3
Maximum drive speed	[rpm]	6666	6666	4500
Gearing type		Crown gear unit		
Gearing		Straight		
Gear ratio		3		

- 1) Total stroke = working stroke + 2x stroke reserve, longer strokes on request
- 2) At 500 mm stroke and with a centred working load in the middle of the guide. Further values → 12
- 3) The acceleration may need to be reduced to achieve optimum positioning times (→ PositioningDrives sizing software).
- 4) Measured at a speed of 0.2m/s

Operating and environmental conditions				
Size		18	25	40
Ambient temperature	[°C]	-10 ... +60		
Protection class		IP20		

Cantilever axes DGEA, with toothed belt drive

Technical data

Weights [kg]							
Size		18		25		40	
Number of drive heads		1	2	1	2	1	2
Basic design							
Overall weight	at 0 mm stroke ¹⁾	2.8	4.7	4.9	8.5	14.3	23.2
	Additional weight Per 100 mm stroke ¹⁾	0.35	0.35	0.47	0.47	1	1
Moving load	at 0 mm stroke	1.5	2	2.4	3.3	6.2	8.6
With angled gear unit							
Overall weight	at 0 mm stroke ¹⁾	3.6	5	6.6	9.3	19.5	26
	Additional weight Per 100 mm stroke ¹⁾	0.35	0.35	0.47	0.47	1	1
Moving load	at 0 mm stroke ¹⁾	1.5	2	2.4	3.3	6.2	8.6

1) Without motor, coupling, coupling housing and accessories

Mass moment of inertia							
Size		18		25		40	
Number of drive heads		1	2	1	2	1	2
J_0	[kg cm ²]	2.87	4.08	4.45	6.40	28	41.5
J_H	per metre stroke [kg cm ² /m]	6		8		36.5	
J_L	per kg working load [kg cm ² /kg]	1.66		1.66		3.65	
J_G	angled gear unit [kg cm ² /m]	0.14		0.26		2.02	
i	gear ratio	3		3		3	

The mass moment of inertia J_A of the entire axis is calculated as follows:

Basic design

$$J_A = J_0 + J_H \times \text{working stroke [m]} + J_L \times m_{\text{working load [kg]}}$$

With angled gear unit

$$J_A = J_G + \frac{J_0 + J_H \times \text{working stroke [m]} + J_L \times m_{\text{working load [kg]}}}{i^2}$$

Toothed belt				
Size		18	25	40
Expansion ¹⁾	[%]	0.037	0.053	0.056
Pitch	[mm]	3	3	5
Effective radius; effective diameter	[mm]	25.78	25.78	38.2
Feed constant	[mm/rev.]	81	81	120
Feed constant with integrated angled gear unit	[mm/rev.]	27	27	40

1) At max. feed force

Cantilever axes DGEA, with toothed belt drive

Technical data

Materials

Sectional view

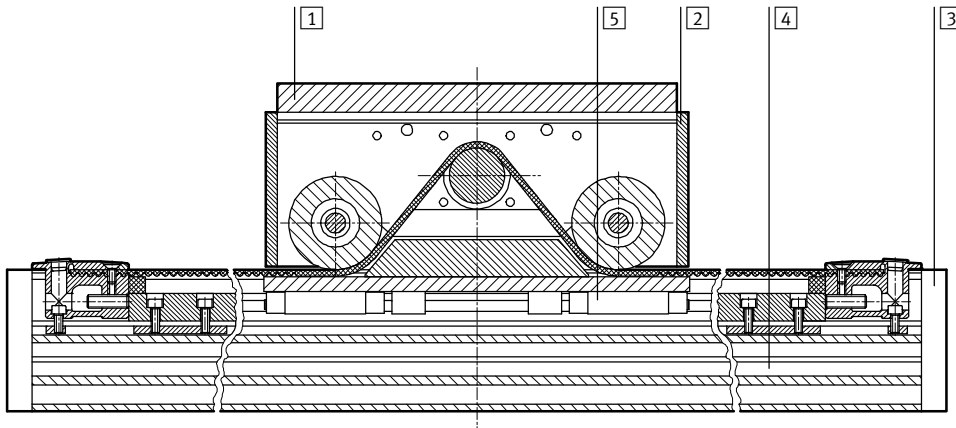

Axis	
1	Drive head interface
2	Drive head - Housing
3	End cap
4	Profile
5	Guide rail
-	Gearing housing
-	Pinion
-	Crown gear

Stroke reserve

- L2 Drive head in the end position of the working stroke
- L8 Distance between mechanical stop and external dimension of the axis
- L9 The stroke reserve is a safety distance available on both sides of the axis in addition to the stroke

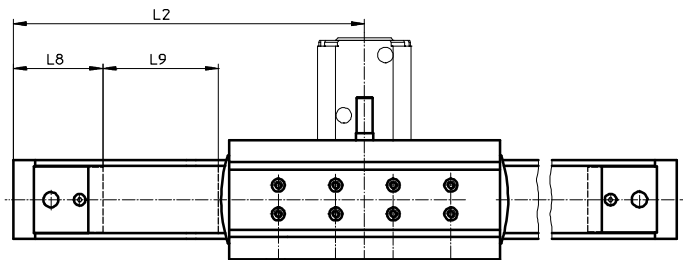

Example:
Type DGEA-25-500-ZR

Working stroke = 500 mm
 Stroke reserve = (2x 81 mm)
 = 162 mm
 Total stroke = 500 mm + 126 mm
 = 662 mm

Size	18	25	40
L9 per end position [mm]	81	81	120

Cantilever axes DGEA, with toothed belt drive

Technical data

Characteristic load values of the guide

The indicated forces and torques refer to the centre of the guide rail. They must not be exceeded in the dynamic range. Special attention must be paid to the cushioning phase.

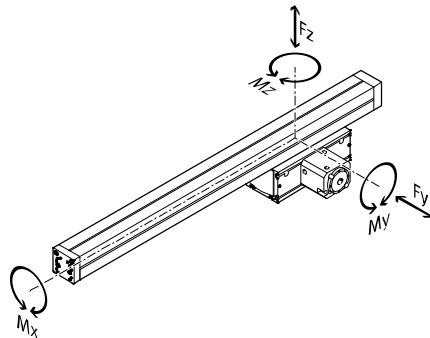

If the cantilever axis is simultaneously subjected to several of the forces and torques listed below, the following equation must be satisfied in addition to the indicated maximum loads.

$$\left| \frac{F_y}{F_{y_{max.}}} \right| + \left| \frac{F_z}{F_{z_{max.}}} \right| + \left| \frac{M_x}{M_{x_{max.}}} \right| + \left| \frac{M_y}{M_{y_{max.}}} \right| + \left| \frac{M_z}{M_{z_{max.}}} \right| \leq 1$$

Permissible forces and torques				
Size		18	25	40
F _{y_{max.}}	[N]	2000	3080	7300
F _{z_{max.}}	[N]	2000	3080	7300
M _{x_{max.}}	[Nm]	19	28	133
M _{y_{max.}}	[Nm]	94	230	665
M _{z_{max.}}	[Nm]	65	160	460

Characteristic load values of the interface for mounting the effective load

The forces and torques specified refer to the interface for mounting the effective load. They must not be exceeded in the dynamic range. Special attention must be paid to the cushioning phase.

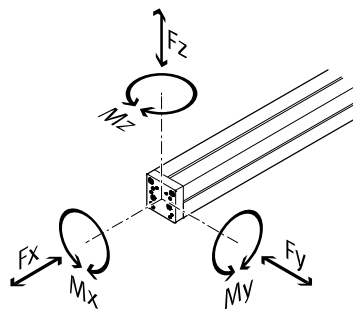

If the cantilever axis is simultaneously subjected to several of the forces and torques listed below, the following equation must be satisfied in addition to the indicated maximum loads.

$$\left| \frac{F_x}{F_{x_{max.}}} \right| + \left| \frac{F_y}{F_{y_{max.}}} \right| + \left| \frac{F_z}{F_{z_{max.}}} \right| + \left| \frac{M_x}{M_{x_{max.}}} \right| + \left| \frac{M_y}{M_{y_{max.}}} \right| + \left| \frac{M_z}{M_{z_{max.}}} \right| \leq 1$$

Permissible forces and torques				
Size		18	25	40
F _{x_{max.}}	[N]	6000	6000	8400
F _{y_{max.}}	[N]	2240	2240	3200
F _{z_{max.}}	[N]	2240	2240	3200
M _{x_{max.}}	[Nm]	30	50	118
M _{y_{max.}}	[Nm]	125	230	407
M _{z_{max.}}	[Nm]	185	273	580

- Note
Sizing software
PositioningDrives
→ www.festo.com

Cantilever axes DGEA, with toothed belt drive

Technical data

2nd moment of area¹⁾

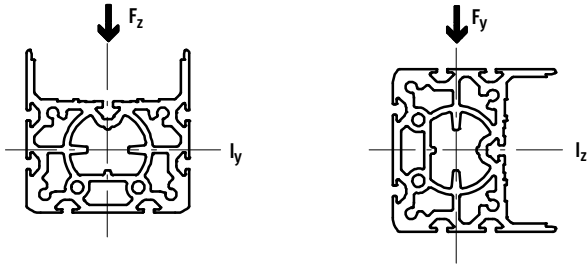

Size		18	25	40
ly	[mm ⁴]	173x10 ³	432x10 ³	1759x10 ³
lz	[mm ⁴]	135x10 ³	438x10 ³	1894x10 ³

1) After machining or replacing the end cap, the values become invalid.

Deflection f of the profile as a function of the distance L and the effective load m

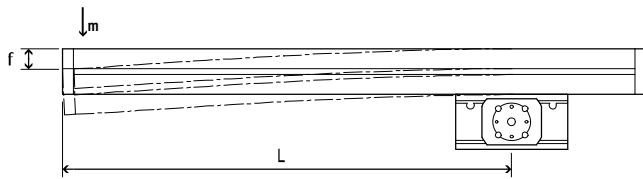

DGEA-18

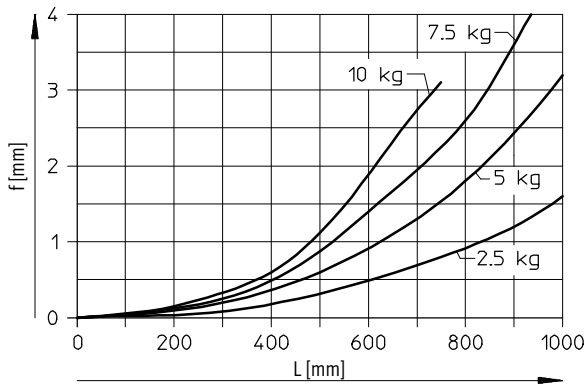

DGEA-25

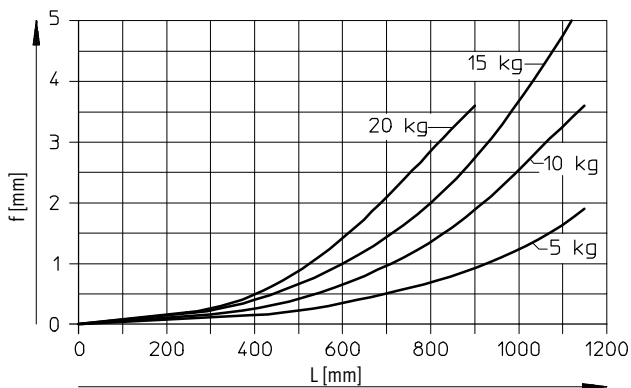

Cantilever axes DGEA, with toothed belt drive

Technical data

Deflection f of the profile as a function of the distance L and the effective load m

DGEA-40

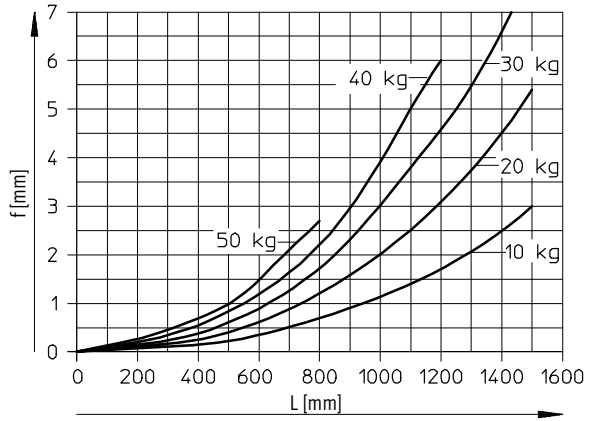

Cantilever axes DGEA, with toothed belt drive

Technical data



Dimensions

Download CAD data → www.festo.com

Basic design

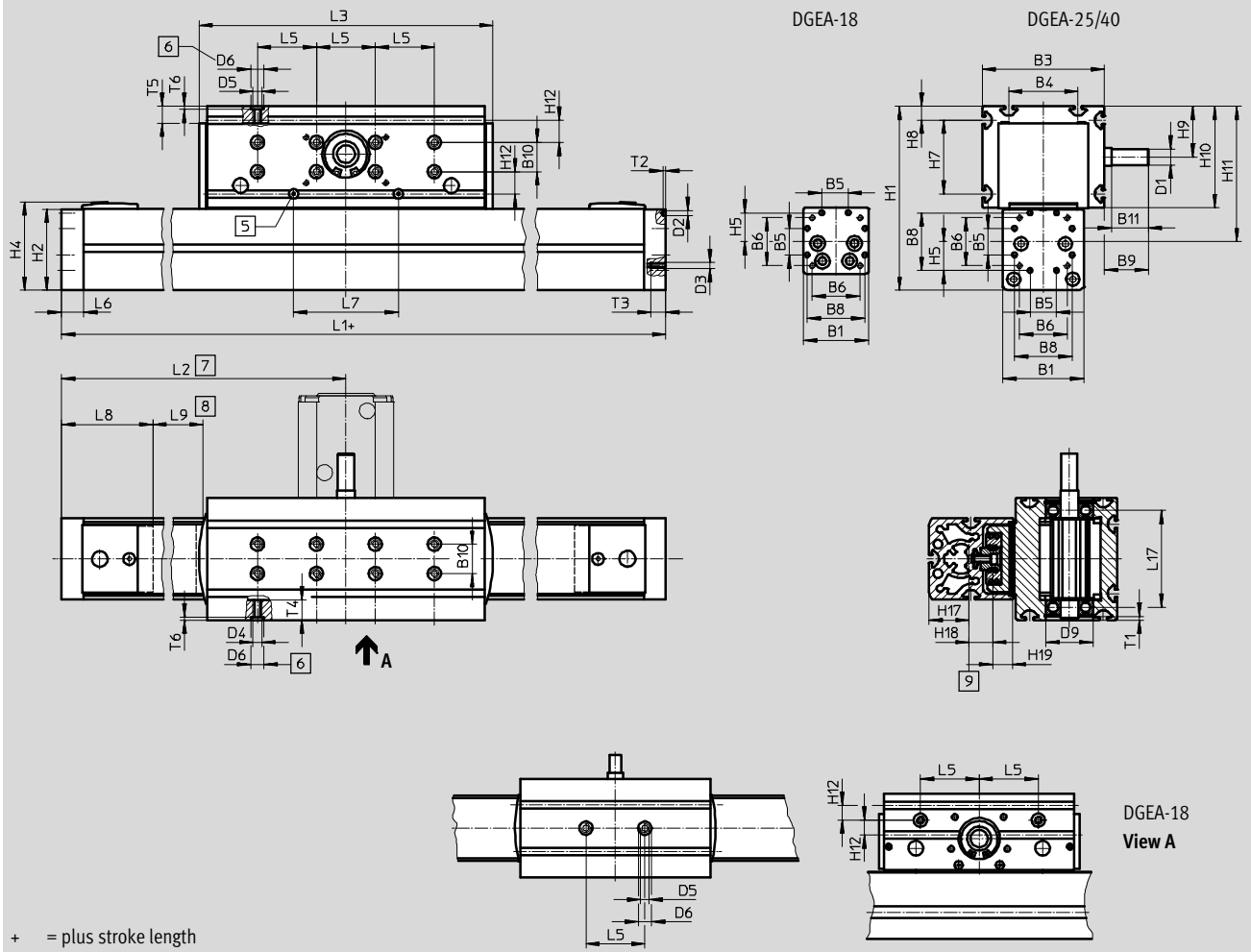

Coupling housing

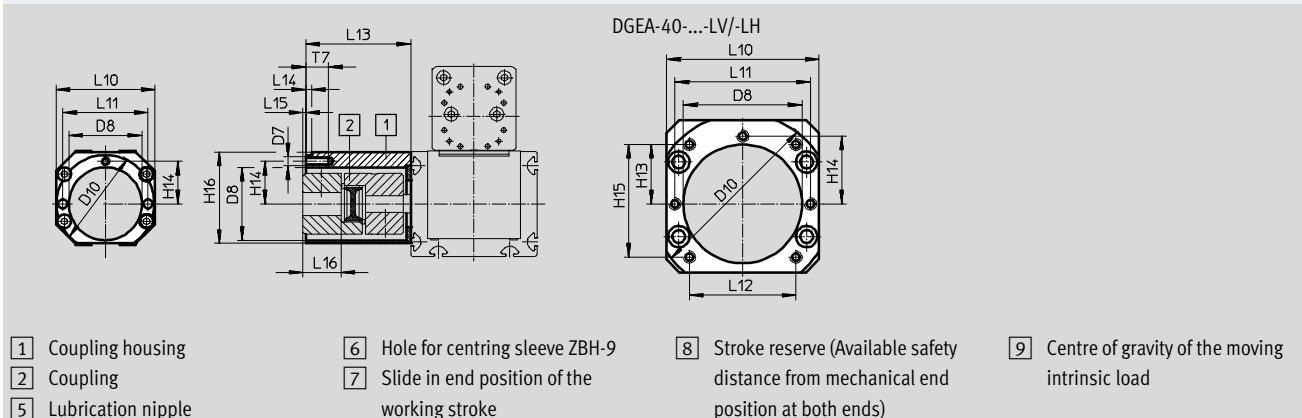

Cantilever axes DGEA, with toothed belt drive

Technical data

Size	Variant	B1	B3	B4	B5 ±0.1	B6	B8	B9	B10	B11	D1 ∅ h6	D2 ∅	D3
18	KV/KH	44	67	32	18	32.5	39.1	16	-	12	8	3.3	M4
25	KV/KH	55	83	47	18	32.5	39.1	29.8	20	25	11	3.3	M4
40	KV/KH	80	111.8	72	28	49	53	30.1	40	25	15	4.4	M5
	LV/LH												

Size	Variant	D4	D5	D6 ∅ H7	D7	D8 ∅	D9 ∅ H7	D10 ∅ g7	H1	H2	H4	H5	H7
18	KV/KH	M6	M6	9	M4	32	28	44	99	45	50.8	19.55	20
25	KV/KH	M6	M6	9	M6	48	32	64	128	57.7	63.1	19.55	50
40	KV/KH	M6	M6	9	M6	48	40	64	197	85	91.3	26.5	72
	LV/LH				M8	78		118					

Size	Variant	H8	H9	H10	H11	H12	H13	H14 ±0.1	H15	H16	H17	H18	H19
18	KV/KH	8	30.5	52	77	10	-	19	-	45	19.6	10	14.3
25	KV/KH	9.5	32.5	69	95	15	-	28	-	60	27.1	16	13.3
40	KV/KH	15.5	55.5	110	153	16	-	28	-	60	42.8	21.5	18
	LV/LH						39	44.5	74	100			

Size	Variant	L1	L2	L3	L5	L6	L7	L8	L9	L10	L11	L12	L13
18	KV/KH	419.5	210	138	40	13	28	58	81	45	38	-	40
25	KV/KH	487.5	244	202	40	15	71	60	81	65	56	-	65
40	KV/KH	662	331	256	40	15	94	81	120	65	56	-	65
	LV/LH									100	89	70	96

Size	Variant	L14	L15	L16	L17	T1	T2	T3	T4 min.	T5 min.	T6	T7
18	KV/KH	3.2	-3.6	14.6	53	1.6	2	9	11	11	2.1	10
25	KV/KH	4	2.2	22.8	65.6	2.3	2	10	11	11	2.1	13
40	KV/KH	4	2.2	22.8	90	2.8	3	10	11	11	2.1	13
	LV/LH	5	-0.9	35.9								18

Cantilever axes DGEA, with toothed belt drive

Technical data

Dimensions Download CAD data → www.festo.com
 With angled gear unit

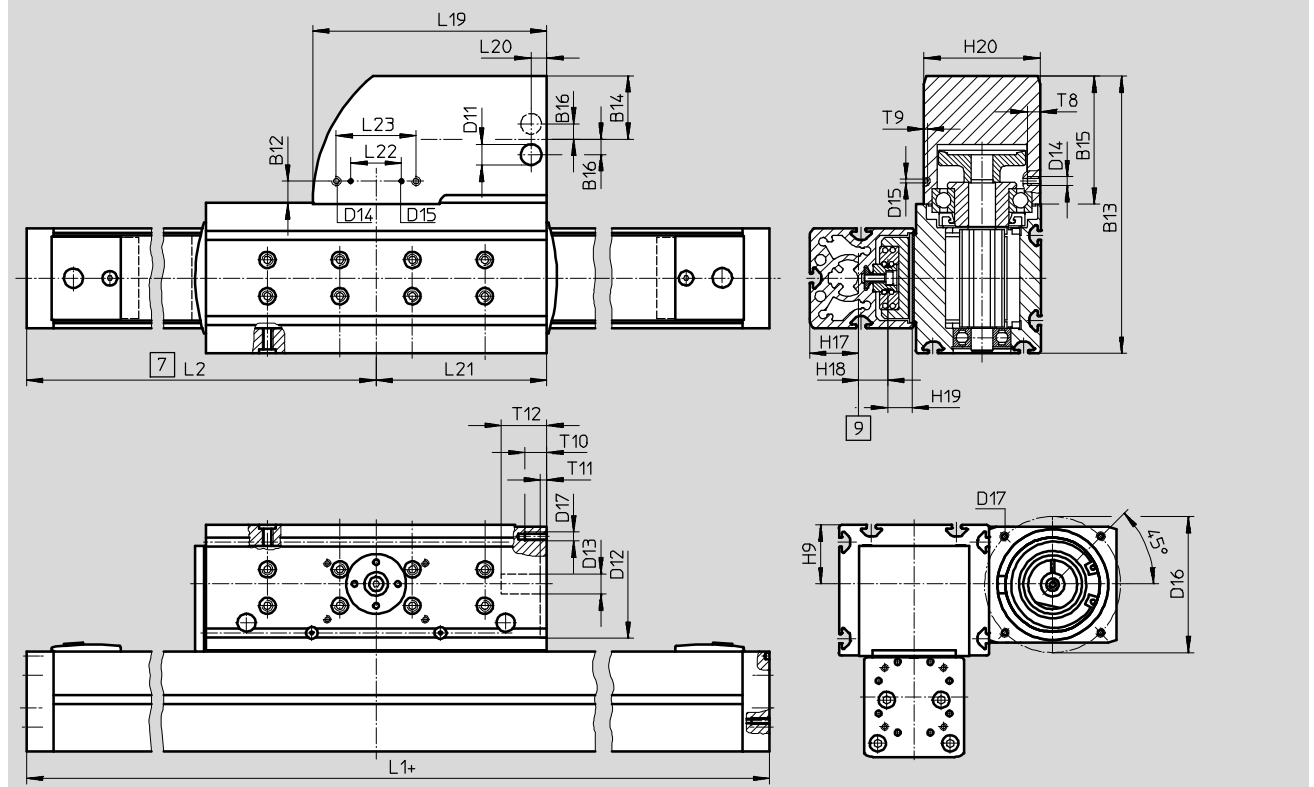

+ = plus stroke length
 [7] Slide in end position of the nominal stroke
 [9] Centre of gravity of the moving intrinsic load

Size	B12	B13	B14	B15	B16	D11 ∅	D12 ∅ +0.05/+0.08	D13 ∅	D14	D15 ∅ ±0.05
18	11	122	27.5	55	9	11.5	40	9	M4	2
25	12	153	35	70	9	11.5	60	11	M5	2
40	16	211.8	50	100	17	11.9	95	19	M5	3

Size	D16 ∅	D17	H9	H17	H18	H19	H20	L1	L2	L19
18	63	M5	30.5	19.6	10	14.3	55	419.5	210	97
25	75	M5	32.5	27.1	16	13.3	64	487.5	244	129
40	115	M8	55.5	42.8	21.5	18	100	662	331	173

Size	L20	L21	L22 ±0.1	L23 ±0.1	T8	T9	T10	T11	T12
18	8.5	64.5	18	34	5	2	12	3.5	24
25	8.5	94	28	44	7	2	12	3.5	25
40	11.5	120	44	68	5	2	12	3.5	40

Cantilever axes DGEA, with toothed belt drive

Technical data

Dimensions

Download CAD data → www.festo.com

with additional drive head

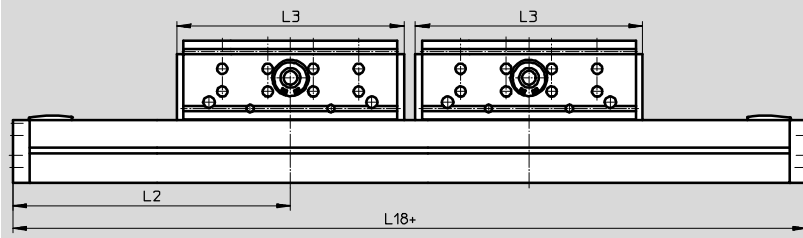

+ = plus stroke length

Note

When using an integrated right-angle gear unit with motor interface on the right (-GVR / -GHR) combined with an additional drive head (-ZWK), a minimum distance between the two drive heads must be observed. When using Festo servo motors, this distance corresponds to at least the overall length of the motor.

Profile barrel

Size 18

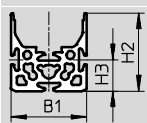

Size 25

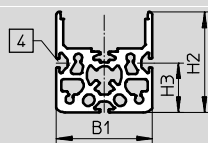

Size 40

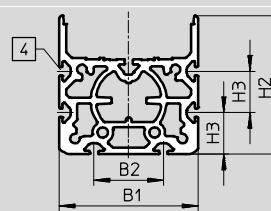

4 Mounting slot for slot nut NST

Size	B1	B2	H2	H3	L2	L3	L18
18	44	–	45	18	210	138	569.5
25	55	–	57.7	28.4	244	202	697.5
40	80	40	85	24	331	256	926

Cantilever axes DGEA, with toothed belt drive

Ordering data – Modules

Order code

Mandatory data/options

WH	Drive shaft, rear
WV	Drive shaft, front
WB	Drive shaft at both ends
ZWK	Second drive head
GVL	Angled gear unit, front left
GVR	Angled gear unit, front right
GHL	Angled gear unit, rear left
GHR	Angled gear unit, rear right

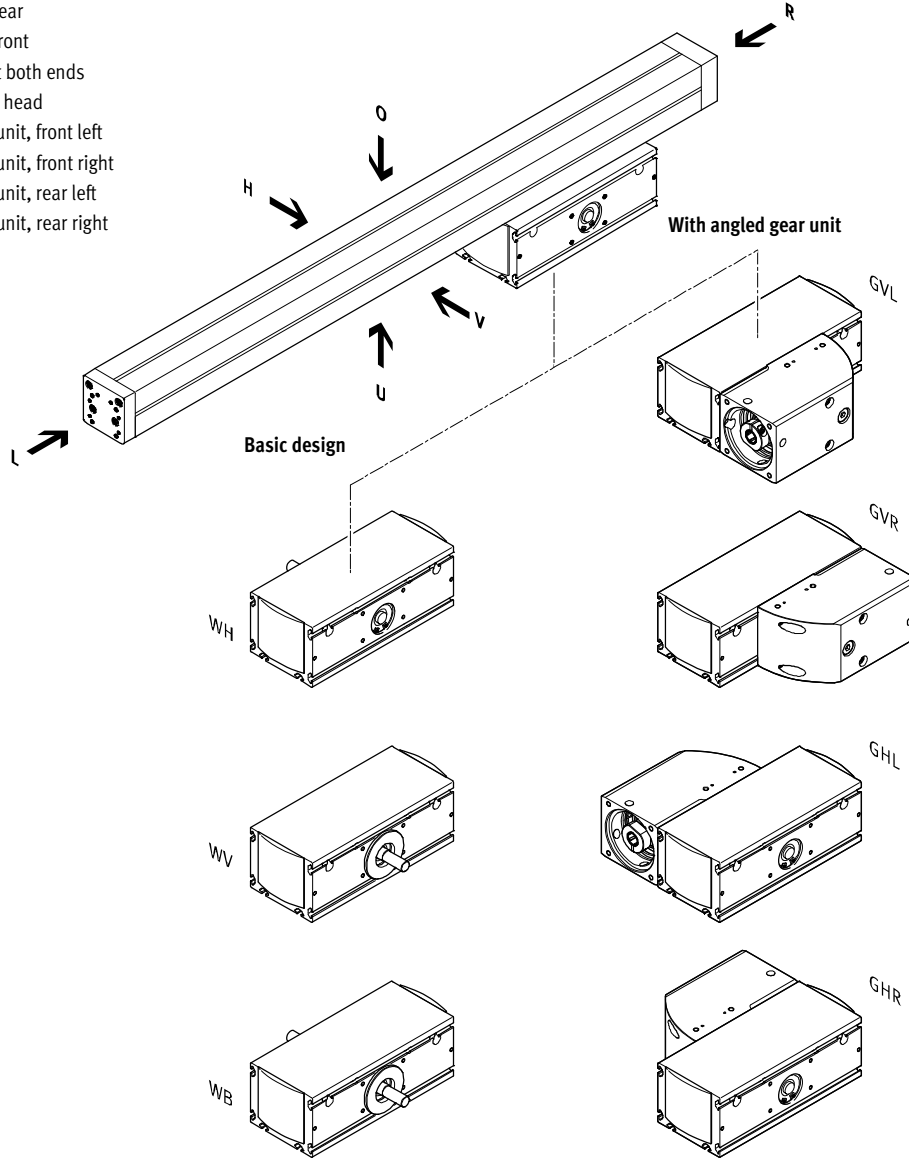

- 1 Drive head
- 2 Optionally:
Additional drive head
(to increase the mechanical
torque resistance)

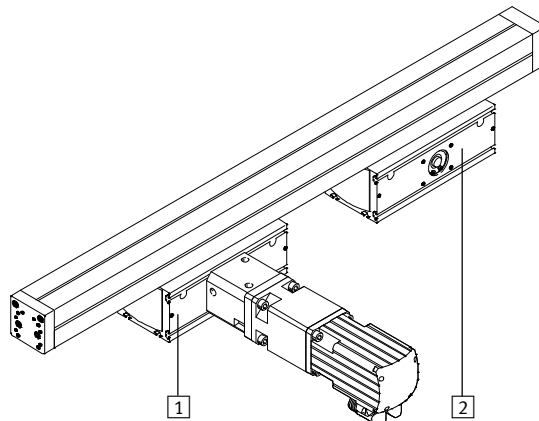

Cantilever axes DGEA, with toothed belt drive

Ordering data – Modules

Order code

Options

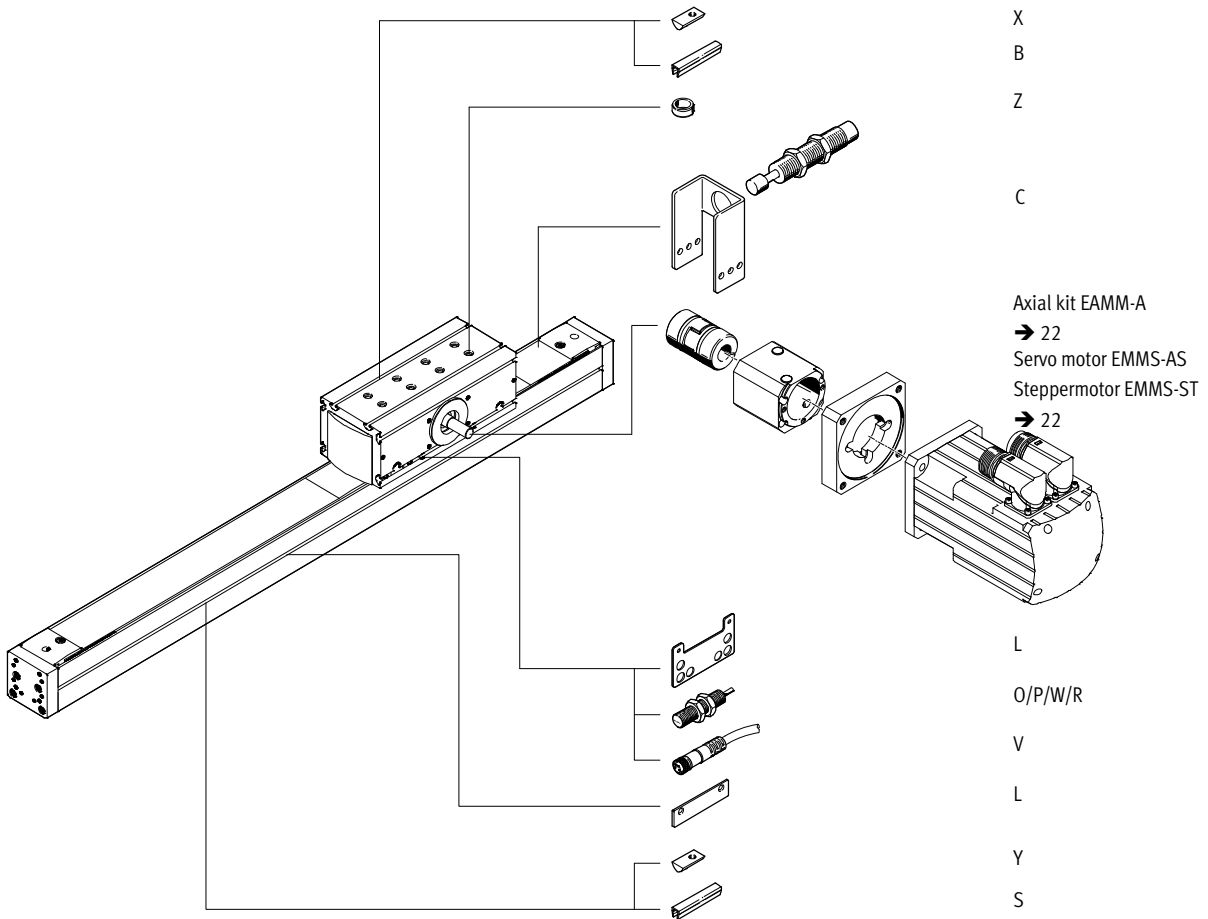

With angled gear unit

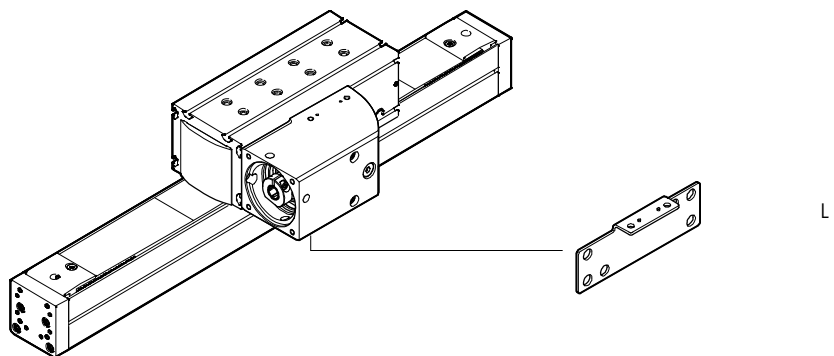

Cantilever axes DGEA, with toothed belt drive

Ordering data – Modules



Mandatory data						Options →
Module No.	Construction	Size	Stroke	Drive function	Drive head	Additional drive head
195611	DGEA	18	1 ... 1000	ZR	WH	ZWK
195612		25			WV	
195613		40			WB GVL GVR GHL GHR	
Ordering example						
195612	DGEA	25	850	ZR	WV	

Ordering table						
Size	18	25	40	Condi- tions	Code	Enter code
M Module No.	195611	195612	195613			
Construction	Cantilever axis with toothed belt drive				DGEA	DGEA
Size	18	25	40		-...	
Stroke [mm]	1 ... 800	1 ... 900	1 ... 1000		-...	
Drive function	Electromechanical drive with toothed belt drive				-ZR	-ZR
Drive head	Drive shaft at rear				-WH	
	Drive shaft at front				-WV	
	Drive shaft at both ends				-WB	
	Integrated angled gear unit for arrangement of motor at front left				-GVL	
	Integrated angled gear unit for arrangement of motor at front right				-GVR	
	Integrated angled gear unit for arrangement of motor at rear left				-GHL	
Integrated angled gear unit for arrangement of motor at rear right				-GHR		
Additional drive head	Without drive shaft				-ZWK	

 Note

When using an integrated right-angle gear unit with motor interface on the right (-GVR / -GHR) combined with an additional drive head (-ZWK), a minimum distance between the two drive heads must be observed. When using Festo servo motors, this distance corresponds to at least the overall length of the motor.

Transfer order code

Cantilever axes DGEA, with toothed belt drive

Ordering data – Modules

Options							
Accessories	Slot cover	Slot nut	Shock absorber with retainer	Centring sleeve	Retaining plate for proximity sensor	Inductive proximity sensor	Cable with socket
ZUB	...S ...B	...Y ...X	...C	...Z	L	...O ...P ...W ...R	...V
ZUB	- 2B		2C	10Z	L	2P2W	2V

Ordering table							
Size		18	25	40	Condi- tions	Code	Enter code
↓	Accessories	Supplied separately				ZUB-	ZUB-
0	Slot cover	for profile slot	1 ... 10			...S	
		for drive head	1 ... 10			...B	
	Slot nut	for profile slot	1 ... 10			...Y	
		for drive head	1 ... 10			...X	
	Shock absorber with retainer		1 ... 2			...C	
	Centring sleeve		10, 20, 30, 40, 50, 60, 70, 80, 90			...Z	
	Retaining plate for inductive proximity switch, incl. 2 switching lugs		1			L	
	Inductive proximity sensor	NO contact, cable	1 ... 5			...O	
		NC contact, cable	1 ... 5			...P	
		NO contact, plug	1 ... 5			...W	
		NC contact, plug	1 ... 5			...R	
	Cable with socket		1 ... 10			...V	

 Note

Cantilever axes DGEA offer the same mounting options (on the end cap of the profile and drive head) as the electromechanical axes DGE-...-ZR-KF/-SP-KF



Note however that there is no 1:1 conformity with regard to size.
Example:
Profile dimension DGEA-18 corresponds to DGE-25.

Transfer order code

ZUB -

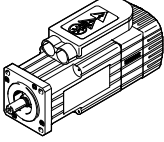
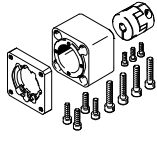

Cantilever axes DGEA, with toothed belt

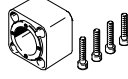
Accessories

Permissible combinations with axial kit – Basic design without gear unit					Technical data → Internet: eamm-a
Motor	Axial kit	Axial kit consisting of:			
		Motor flange	Coupling	Coupling housing	
					
Type	Part No. Type	Part No. Type	Part No. Type	Part No. Type	
DGEA-18					
With stepper motor					
EMMS-ST-57-...	550956 EAMM-A-F28-57A	530081 EAMF-A-44A/B-57A	530088 EAMC-30-35-6.35-8	530468 EAMK-A-F28-44A	
EMMS-ST-87-...	550958 EAMM-A-F28-87A	530082 EAMF-A-44A/B-87A	123042 EAMC-30-35-8-11	530468 EAMK-A-F28-44A	
DGEA-25					
With stepper motor					
EMMS-ST-87-...	550960 EAMM-A-F32-87A	533140 EAMF-A-64A/B-87A	530090 EAMC-40-66-11-11	530469 EAMK-A-F32-64A	

Cantilever axes DGEA, with toothed belt

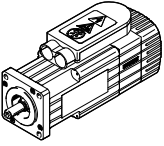
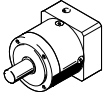
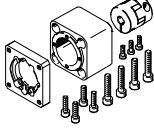

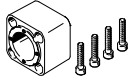
Accessories

Permissible combinations with axial kit – Basic design with gear unit						Technical data → Internet: eamm-a
Motor	Gear units	Axial kit	Axial kit consisting of:			
			Motor flange	Coupling	Coupling housing	
						
Type	Type	Part No. Type	Part No. Type	Part No. Type	Part No. Type	
DGEA-18						
With servo motor						
EMME-AS-40-...	EMGA-40-P-G...-EAS-40	1454251 EAMM-A-F28-40G	550986 EAMF-A-44A/B-40G	123050 EAMC-30-35-8-10	530468 EAMK-A-F28-44A	
EMMS-AS-40-...	EMGA-40-P-G...-SAS-40	1454251 EAMM-A-F28-40G	550986 EAMF-A-44A/B-40G	123050 EAMC-30-35-8-10	530468 EAMK-A-F28-44A	
EMMS-AS-55-...	EMGA-60-P-G...-SAS-55	550957 EAMM-A-F28-60G	529944 EAMF-A-44A/B-60G	123042 EAMC-30-35-8-11	530468 EAMK-A-F28-44A	
EMME-AS-60-...	EMGA-60-P-G...-EAS-60	1454252 EAMM-A-F28-60H	1780430 EAMF-A-44A-60G/H	1453063 EAMC-30-35-8-14	530468 EAMK-A-F28-44A	
EMMS-AS-70-...	EMGA-60-P-G...-SAS-70	550957 EAMM-A-F28-60G	529944 EAMF-A-44A/B-60G	123042 EAMC-30-35-8-11	530468 EAMK-A-F28-44A	
With stepper motor						
EMMS-ST-42-...	EMGA-40-P-G...-SST-42	1454251 EAMM-A-F28-40G	550986 EAMF-A-44A/B-40G	123050 EAMC-30-35-8-10	530468 EAMK-A-F28-44A	
EMMS-ST-57-...	EMGA-60-P-G...-SST-57	550957 EAMM-A-F28-60G	529944 EAMF-A-44A/B-60G	123042 EAMC-30-35-8-11	530468 EAMK-A-F28-44A	
With integrated drive						
EMCA-EC-67-...	EMGC-40-...	1454251 EAMM-A-F28-40G	550986 EAMF-A-44A/B-40G	123050 EAMC-30-35-8-10	530468 EAMK-A-F28-44A	
EMCA-EC-67-...	EMGC-60-...	1454252 EAMM-A-F28-60H	1780430 EAMF-A-44A-60G/H	1453063 EAMC-30-35-8-14	530468 EAMK-A-F28-44A	
DGEA-25						
With servo motor						
EMMS-AS-55-...	EMGA-60-P-G...-SAS-55	550959 EAMM-A-F32-60G	550987 EAMF-A-64A/B-60G	530090 EAMC-40-66-11-11	530469 EAMK-A-F32-64A	
EMME-AS-60-...	EMGA-60-P-G...-EAS-60	1454256 EAMM-A-F32-60H	550987 EAMF-A-64A/B-60G	1452798 EAMC-40-66-11-14	530469 EAMK-A-F32-64A	
EMMS-AS-70-...	EMGA-60-P-G...-SAS-70	550959 EAMM-A-F32-60G	550987 EAMF-A-64A/B-60G	530090 EAMC-40-66-11-11	530469 EAMK-A-F32-64A	
With stepper motor						
EMMS-ST-57-...	EMGA-60-P-G...-SST-57	550959 EAMM-A-F32-60G	550987 EAMF-A-64A/B-60G/H	530090 EAMC-40-66-11-11	530469 EAMK-A-F32-64A	
With integrated drive						
EMCA-EC-67-...	EMGC-60-...	1454256 EAMM-A-F32-60H	550987 EAMF-A-64A/B-60G/H	1452798 EAMC-40-66-11-14	530469 EAMK-A-F32-64A	

Cantilever axes DGEA, with toothed belt

Accessories

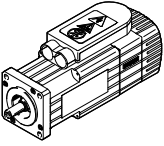
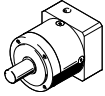
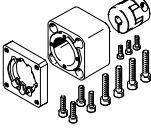

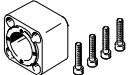
Permissible combinations with axial kit – Basic design with gear unit						Technical data → Internet: eamm-a
Motor	Gear unit	Axial kit	Axial kit consisting of:			
			Motor flange	Coupling	Coupling housing	
						
Type	Type	Part No. Type	Part No. Type	Part No. Type	Part No. Type	
DGEA-40						
With servo motor						
EMMS-AS-70-...	EMGA-80-P-G...-SAS-70	550935 EAMM-A-F40-80G	533139 EAMF-A-64A/C-80G	123845 EAMC-40-66-15-20	124629 EAMK-A-F40-64A	
EMME-AS-80-...	EMGA-80-P-G...-EAS-80	550935 EAMM-A-F40-80G	533139 EAMF-A-64A/C-80G	123845 EAMC-40-66-15-20	124629 EAMK-A-F40-64A	
EMME-AS-100-...	EMGA-80-P-G...-SAS-100	550935 EAMM-A-F40-80G	533139 EAMF-A-64A/C-80G	123845 EAMC-40-66-15-20	124629 EAMK-A-F40-64A	
EMMS-AS-100-...	EMGA-80-P-G...-SAS-100	550935 EAMM-A-F40-80G	533139 EAMF-A-64A/C-80G	123845 EAMC-40-66-15-20	124629 EAMK-A-F40-64A	
With stepper motor						
EMMS-ST-87-...	EMGA-80-P-G...-SST-87	550935 EAMM-A-F40-80G	533139 EAMF-A-64A/C-80G	123845 EAMC-40-66-15-20	124629 EAMK-A-F40-64A	

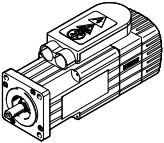
Permissible combinations with right-angle gear unit
Motor

Type
DGEA-18
With servo motor
EMMS-AS-55-...
DGEA-25
With servo motor
EMMS-AS-70-...
DGEA-40
With servo motor
EMMS-AS-100-...

Cantilever axes DGEA, with toothed belt

Accessories

Mounting kit for proximity sensor
(DGEA in basic design)

DGEA-...-SIE-M8

(order code L)

Material:

Galvanised steel

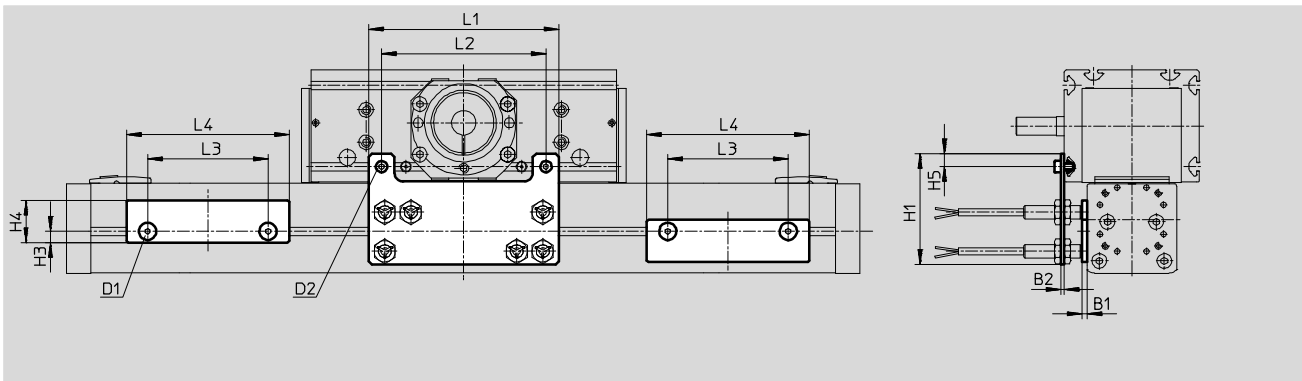

Dimensions and ordering data							
For size	B1	B2	D1	D2	H1	H3	H4
18	3	2	M4	M4	77	5	21
25	3	2	M4	M5	68	7	26
40	3	7	M4	M5	92	7	26

For size	H5	L1	L2	L3	L4	Weight [g]	Part No.	Type
18	7.5	114	90	74	84	200	525868	DGEA-18-SIE-M8
25	8	117	101	85	100	250	525869	DGEA-25-SIE-M8
40	10	190	133	124.5	145	600	525870	DGEA-40-SIE-M8

Cantilever axes DGEA, with toothed belt

Accessories



Mounting kit for proximity sensor
(DGEA with right-angle gear unit)

DGEA-...-G...-SIE-M8

(order code L)

Material:

Galvanised steel

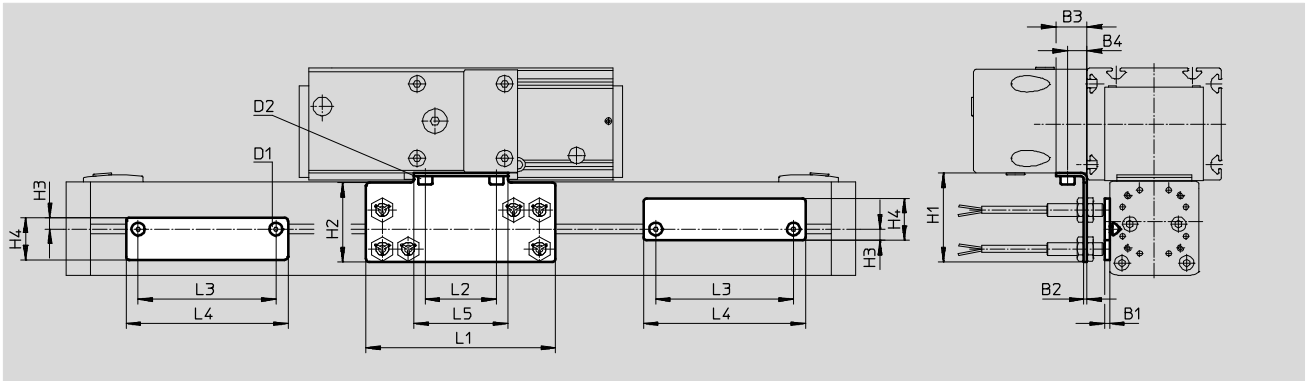

Dimensions and ordering data

For size	B1	B2	B3	B4	D1	D2	H1	H2	H3
18	3	2	17	11	M4	M4	40	34	5
25	3	2	19	12	M4	M5	55	49	7
40	3	4	23	16	M4	M5	64	52	7

For size	H4	L1	L2	L3	L4	L5	Weight [g]	Part No.	Type
18	21	114	34	74	84	46	170	539935	DGEA-18-G...-SIE-M8
25	26	117	44	85	100	58	250	539936	DGEA-25-G...-SIE-M8
40	26	153	68	124.5	145	82	520	539937	DGEA-40-G...-SIE-M8

Cantilever axes DGEA, with toothed belt

Accessories

Shock absorber kit

DGEA-...-YSR

(order code C)

Material:

Galvanised steel

Free of copper and PTFE

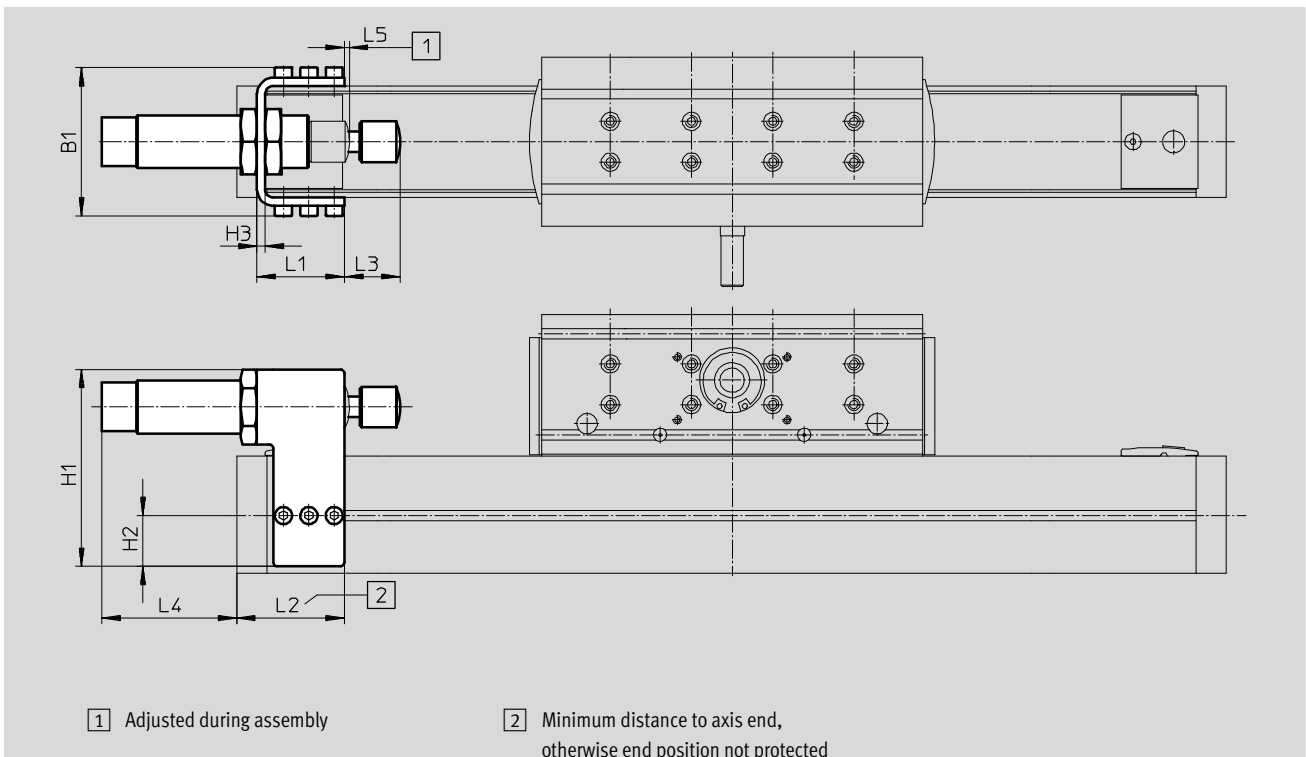



Dimensions and ordering data												
For size	B1	H1	H2	H3	L1	L2 +1	L3	L4	L5 +1	Weight [g]	Part No.	Type
18	59	80	15	3	44	67	1)	1)	2	390	525865	DGEA-18-YSR
25	73	97	25	4	43	60	1)	1)	2	630	525866	DGEA-25-YSR
40	98	122	14	4	70.5	81	1)	1)	2	1200	525867	DGEA-40-YSR





1) Dimension is related to the size of the shock absorber and the mounting position of the shock absorber kit

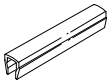

Cantilever axes DGEA, with toothed belt

Accessories

Ordering data				Technical data → Internet: mounting attachment		
	For size	Comment	Order code	Part No.	Type	PU ¹⁾
Slot nut NST						
	18	For profile slot	Y	526091	NST-HMV-M4	10
	25, 40			150914	NST-5-M5	1
	18, 25, 40	For drive head		X	150914	NST-5-M5
Centring sleeve ZBH						
	18, 25, 40	For drive head	Z	150927	ZBH-9	10
Slot cover ABP/ABP-S						
	18	For profile slot every 0.5 m	S	151680	ABP-5-S	2
	25, 40			151681	ABP-5	2
	18, 25, 40	For drive head every 0.5 m		B	151681	ABP-5

1) Packaging unit

Ordering data – Inductive proximity sensors M8					Technical data → Internet: sien		
	Electrical connection		Switching output	LED	Cable length [m]	Part No.	Type
	Cable	Plug M8					
N/O contact							
	3-wire	–	PNP	■	2.5	150386	SIEN-M8B-PS-K-L
	–	3-pin	PNP	■	–	150387	SIEN-M8B-PS-S-L
N/C contact							
	3-wire	–	PNP	■	2.5	150390	SIEN-M8B-PO-K-L
	–	3-pin	PNP	■	–	150391	SIEN-M8B-PO-S-L

Ordering data – Connecting cables				Technical data → Internet: nebu	
	Electrical connection, left	Electrical connection, right	Cable length [m]	Part No.	Type
	Straight socket, M8x1, 3-pin	Cable, open end, 3-wire	2.5	541333	NEBU-M8G3-K-2.5-LE3
			5	541334	NEBU-M8G3-K-5-LE3
	Angled socket, M8x1, 3-pin	Cable, open end, 3-wire	2.5	541338	NEBU-M8W3-K-2.5-LE3
			5	541341	NEBU-M8W3-K-5-LE3

Cantilever axes DGEA, with toothed belt

Accessories

**Adapter kit
HMVK**

Material:
Wrought aluminium alloy
Free of copper and PTFE
RoHS-compliant

 Note
The kit includes the individual mounting interface as well as the necessary mounting material.

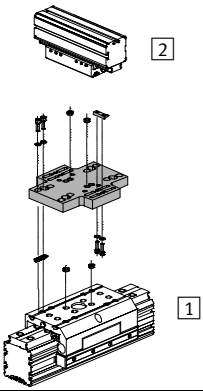
Permissible drive/drive combinations with adapter kit			Download CAD data → www.festo.com		
Combination	1 Drive	2 Drive	Adapter kit		
	Size	Size	CRC ¹⁾	Part No.	Type
DG.../DGEA	DG...	DGEA	HMVK		
	40	18, 25	2	196781	HMVK-DL32/40-DLA18-32
	63	25, 40		196783	HMVK-DL63-DLA25/40

1) Corrosion resistance class CRC 2 to Festo standard FN 940070
Moderate corrosion stress. Indoor applications in which condensation may occur. External visible parts with primarily decorative requirements for the surface and which are in direct contact with the ambient atmosphere typical for industrial applications.

Product Range and Company Overview

A Complete Suite and Company Overview

Our experienced engineers provide complete support at every stage of your development process, including: conceptualization, analysis, engineering, design, assembly, documentation, validation, and production.



Custom Automation Components
Complete custom engineered solutions



Custom Control Cabinets
Comprehensive engineering support and on-site services



Complete Systems
Shipment, stocking and storage services

The Broadest Range of Automation Components

With a comprehensive line of more than 30,000 automation components, Festo is capable of solving the most complex automation requirements.



Electromechanical
Electromechanical actuators, motors, controllers & drivers



Pneumatics
Pneumatic linear and rotary actuators, valves, and air supply



PLCs and I/O Devices
PLC's, operator interfaces, sensors and I/O devices

Supporting Advanced Automation... As No One Else Can!

Festo is a leading global manufacturer of pneumatic and electromechanical systems, components and controls for industrial automation, with more than 16,000 employees in 60 national headquarters serving more than 180 countries. For more than 80 years, Festo has continuously elevated the state of manufacturing with innovations and optimized motion control solutions that deliver higher performing, more profitable automated manufacturing and processing equipment. Our dedication to the advancement of automation extends beyond technology to the education and development of current and future automation and robotics designers with simulation tools, teaching programs, and on-site services.

Quality Assurance, ISO 9001 and ISO 14001 Certifications

Festo Corporation is committed to supply all Festo products and services that will meet or exceed our customers' requirements in product quality, delivery, customer service and satisfaction.

To meet this commitment, we strive to ensure a consistent, integrated, and systematic approach to management that will meet or exceed the requirements of the ISO 9001 standard for Quality Management and the ISO 14001 standard for Environmental Management.



© Copyright 2013, Festo Corporation. While every effort is made to ensure that all dimensions and specifications are correct, Festo cannot guarantee that publications are completely free of any error, in particular typing or printing errors. Accordingly, Festo cannot be held responsible for the same. For Liability and Warranty conditions, refer to our "Terms and Conditions of Sale", available from your local Festo office. All rights reserved. No part of this publication may be reproduced, distributed, or transmitted in any form or by any means, electronic, mechanical, photocopying or otherwise, without the prior written permission of Festo. All technical data subject to change according to technical update.



Printed on recycled paper at New Horizon Graphic, Inc., FSC certified as an environmental friendly printing plant.

Festo North America

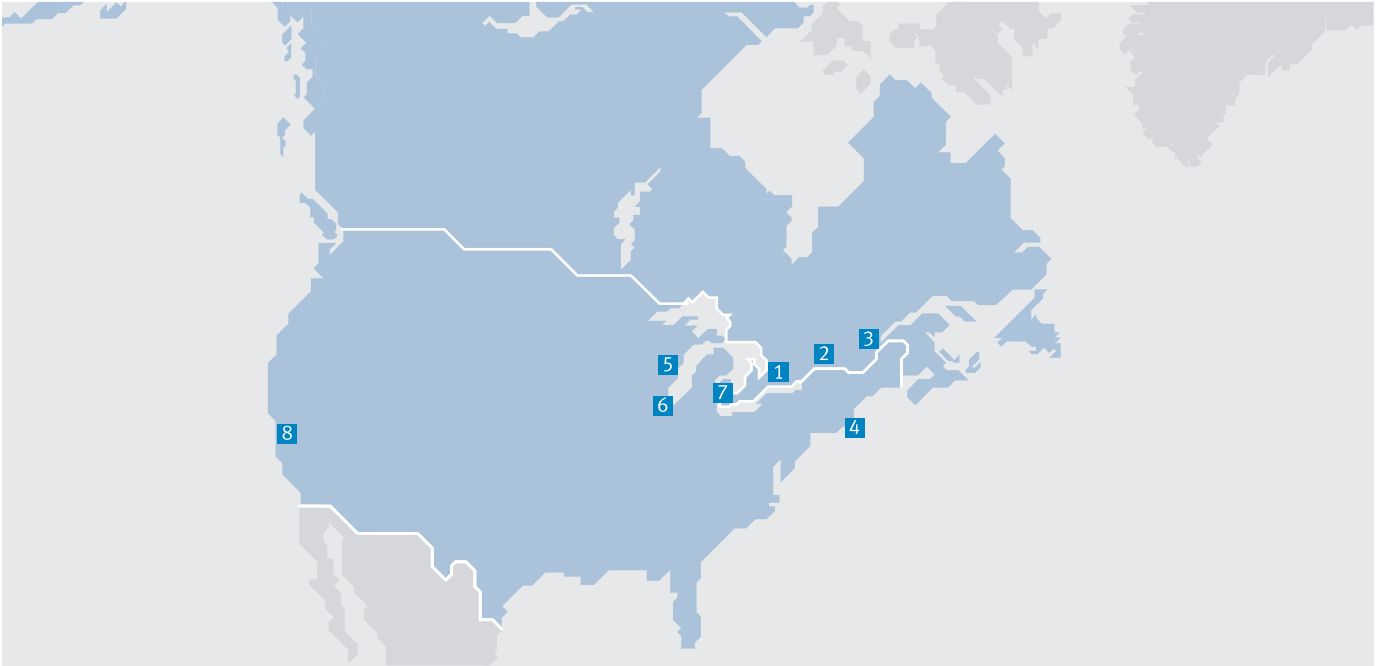

**1 Festo Canada
Headquarters
Festo Inc.**
5300 Explorer Drive
Mississauga, ON
L4W 5G4

2 Montréal
5600, Trans-Canada
Pointe-Claire, QC
H9R 1B6

3 Québec City
2930, rue Watt#117
Québec, QC
G1X 4G3



**4 Festo United States
Headquarters
Festo Corporation**
395 Moreland Road
Hauppauge, NY
11788

5 Appleton
North 922 Tower View Drive, Suite N
Greenville, WI
54942

7 Detroit
1441 West Long Lake Road
Troy, MI
48098

6 Chicago
85 W Algonquin - Suite 340
Arlington Heights, IL
60005

8 Silicon Valley
4935 Southfront Road, Suite F
Livermore, CA
94550

Festo Regional Contact Center

Canadian Customers

Commercial Support:
Tel: 1 877 GO FESTO (1 877 463 3786)
Fax: 1 877 FX FESTO (1 877 393 3786)
Email: festo.canada@ca.festo.com

Technical Support:
Tel: 1 866 GO FESTO (1 866 463 3786)
Fax: 1 877 FX FESTO (1 877 393 3786)
Email: technical.support@ca.festo.com

USA Customers

Commercial Support:
Tel: 1 800 99 FESTO (1 800 993 3786)
Fax: 1 800 96 FESTO (1 800 963 3786)
Email: customer.service@us.festo.com

Technical Support:
Tel: 1 866 GO FESTO (1 866 463 3786)
Fax: 1 800 96 FESTO (1 800 963 3786)
Email: product.support@us.festo.com