

# Spindle axes DGE



# Spindle axes DGE

Key features

FESTO

## At a glance

- Precision, rigid guide
- Highly adaptable, thanks to wide choice of mounting and attachment options
- Wide range of options for attaching drive units
- Comprehensive range of mounting accessories for multi-axis combinations
- Optimally adapted motor controller combinations

## Basic version DGE-SP

- Stroke lengths from 100 ... 2000 mm
- Without guide
- Low characteristic load values



## With recirculating ball bearing guide DGE-SP-KF-GK/-GV

- Stroke lengths from 100 ... 2000 mm
- Standard slide or extended slide
- Medium to high characteristic load values



## With protected version DGE-SP-KF-GA

- Stroke lengths from 140 ... 1500 mm
- Guide and slide are fitted with a cover to protect against the ingress of particles from above and from the side



# Spindle axes DGE

Key features

## System selection for electromechanical drives

Spindle axis



-  - Note

For the spindle axes and the motors there are matching complete solutions.

### Motor kit

Axial kit

Parallel kit

→ 42



Axial kit consisting of:

- Motor flange
- Coupling housing
- Coupling
- Screws

### Motor

→ 42



- 1 Servo motor EMME-AS, EMMS-AS
- 2 Stepper motor EMMS-ST

### Motor controller

Technical data → Internet: motor controller



- 1 Servo motor controller CMMP-AS
- 2 Stepper motor controller CMMS-ST

# Spindle axes DGE

System example

System product for handling and assembly technology

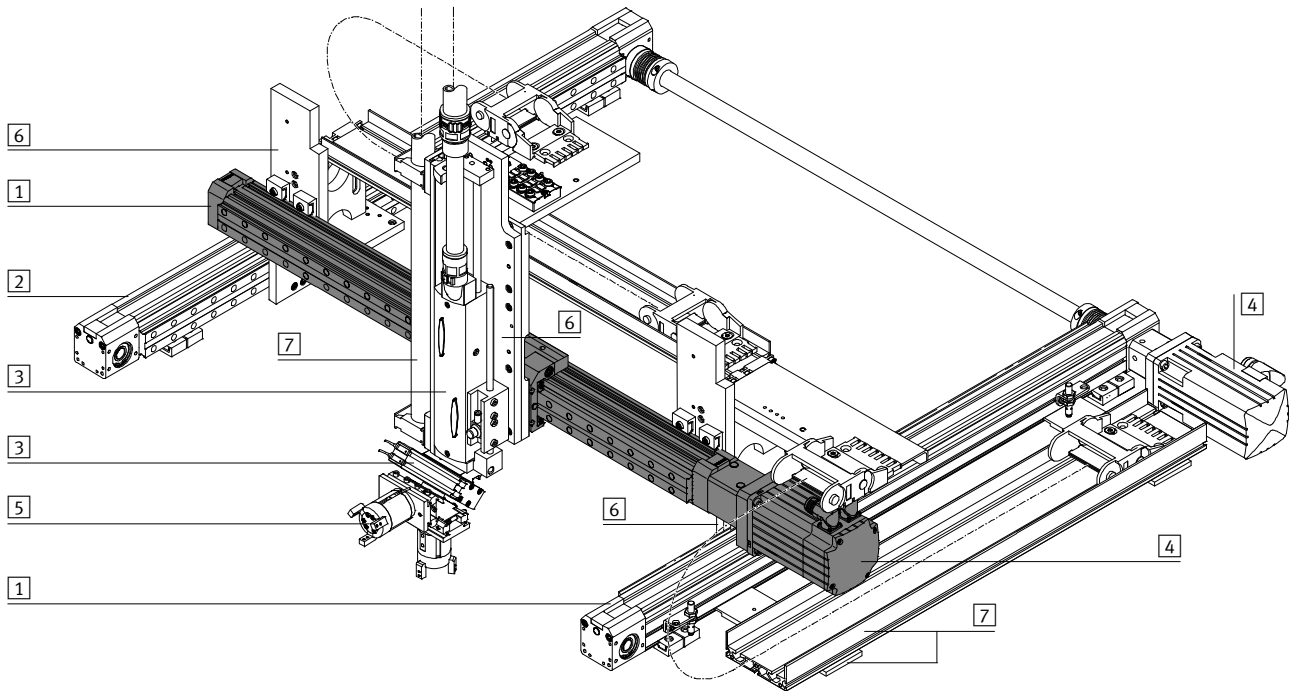

System components and accessories		
Type	Description	→ Page/Internet
1	Axes	Wide range of combination options within handling and assembly technology axes
2	Passive guide axes	Diverse possible combinations in handling and assembly technology guide axes
3	Drives	Wide range of combination options within handling and assembly technology drive
4	Motors	Servo and stepper motors, with or without gearing motor
5	Grippers	Wide range of combination options within handling and assembly technology gripper
6	Adapters	For drive/drive combinations 53
		For drive/gripper combinations gripper
7	Installation components	For achieving a clear-cut, safe layout for electrical cables and tubing installation component

# Spindle axes DGE

Selection aid

## Guide characteristics

The data in the table are maximum values. The precise values for each variant can be found in the corresponding data sheet included in the catalogue.

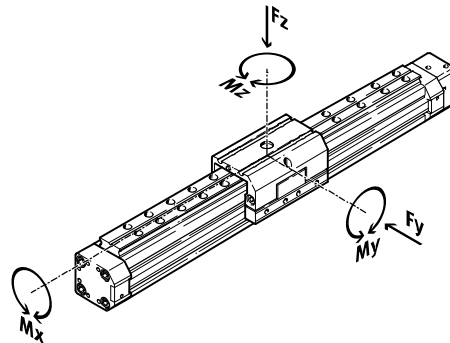

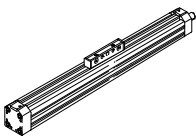
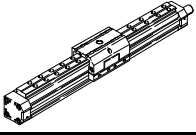
Version	Size	Working stroke [mm]	Speed [m/s]	Repetition accuracy [mm]	Feed force [N]	Forces and torques					→ Page/Internet
						Fy [N]	Fz [N]	Mx [Nm]	My [Nm]	Mz [Nm]	
<b>Basic version without guide SP</b>											
	18	100 ... 500	0.2	±0.02	140	–	1.8	0.5	0.8	0.8	6
	25	100 ... 1000	0.5	±0.02	250	–	2	1	1.5	1.5	
	40	200 ... 1500	1	±0.02	600	–	15	4	4	4	
	63	300 ... 2000	1.2	±0.02	1600	–	106	8	18	18	
<b>With recirculating ball bearing guide SP-KF</b>											
	18	100 ... 500	0.2	±0.02	140	930	930	7	45	45	20
	25	100 ... 1000	0.5	±0.02	250	3080	3080	45	170	170	
	40	140 ... 1500	1	±0.02	600	7300	7300	170	660	660	
	63	150 ... 2000	1.2	±0.02	1600	14050	14050	580	1820	1820	

# Spindle axes DGE-SP

Peripherals overview

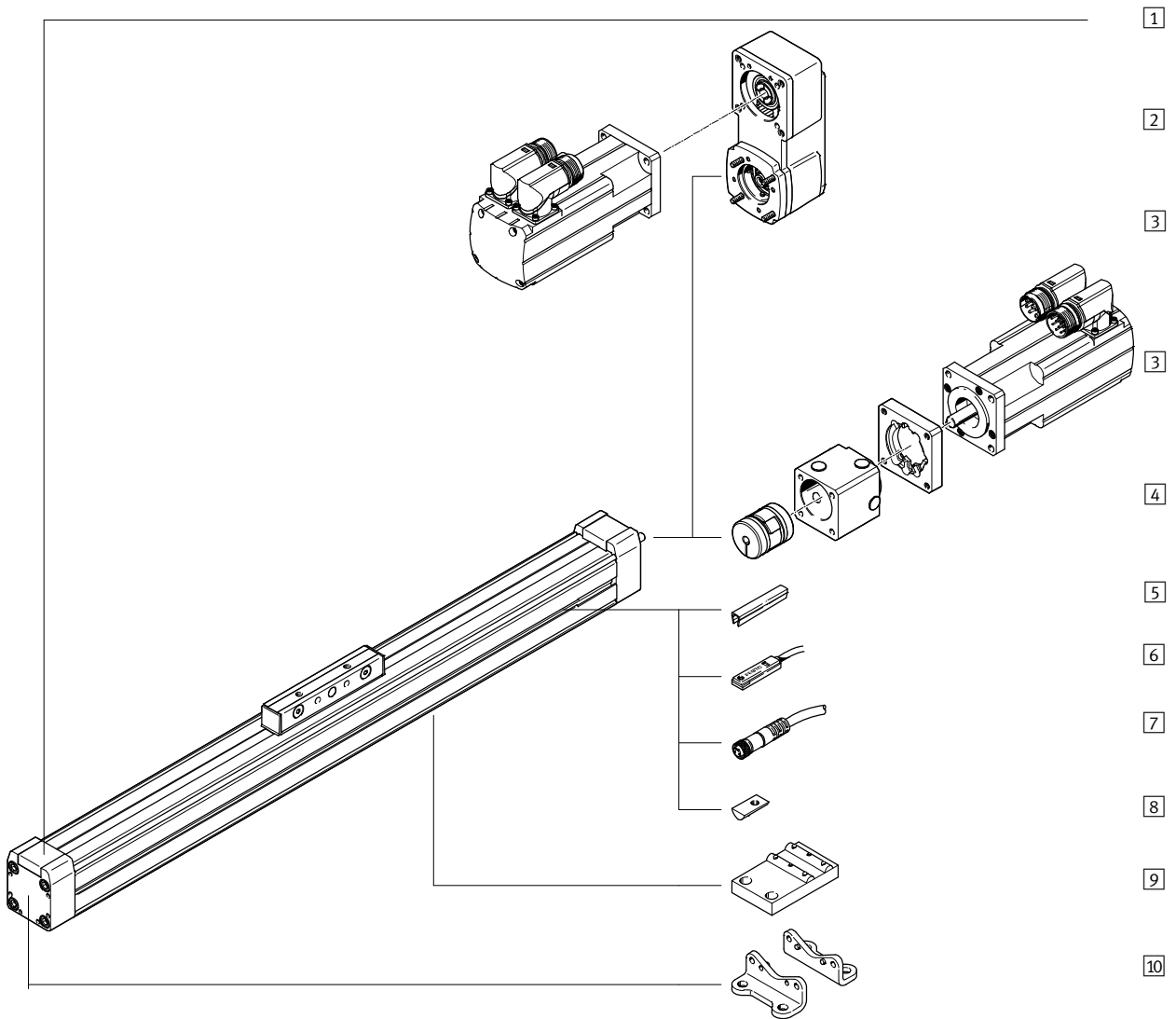
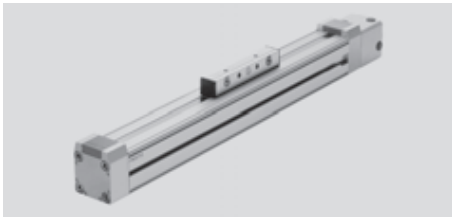

# Spindle axes DGE-SP

Peripherals overview

Variants and accessories		
Type	Description	→ Page/Internet
1 Spindle axis DGE-SP	Electromechanical axis without guide	8
2 Parallel kit EAMM-U	For parallel motor attachment (consisting of: housing, Clamping component, clamping sleeve, toothed belt gearwheel, toothed belt)	45
3 Motor EMMS	Motors specially matched to the axis, with or without gearing, with or without brake	42
4 Axial kit EAMM-A	For axial motor attachment (consisting of: coupling housing, clamping component, motor flange)	42
5 Slot cover B/S	For protecting against the ingress of dirt	51
6 Proximity sensor G/H/I/J/N	For use as a signal generator and safety monitoring	52
7 Cable with socket V	For proximity sensors	52
8 Slot nut for mounting slot Y	For mounting attachments	51
9 Central support M	For mounting the axis	46
10 Foot mounting F	For mounting the axis	46

# Spindle axes DGE-SP

Type code

		DGE	-	25	-	500	-	SP	+ZUB	-					F	2G	
<b>Type</b>																	
DGE	Spindle axis																
<b>Size</b>																	
<b>Stroke [mm]</b>																	
<b>Drive function</b>																	
SP	Spindle																
<b>Accessories</b>																	
ZUB	Accessories supplied loos																
<b>Slot cover</b>																	
...S	Sensor slot																
...B	Mounting slot																
<b>Slot nut</b>																	
...Y	For mounting slot																
<b>Central support</b>																	
...M	Central support																
<b>Foot mounting</b>																	
...F	Foot mounting																
<b>Proximity sensor</b>																	
...G	With cable, 2.5 m																
...H	With plug																
...I	Contactless with cable, 2.5 m																
...J	Contactless, plug																
...N	NC contact with cable, 2.5 m																
<b>Cable with socket</b>																	
...V	2.5 m																



# Spindle axes DGE-SP

Technical data

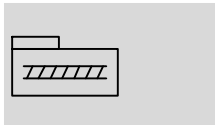

FESTO

Function

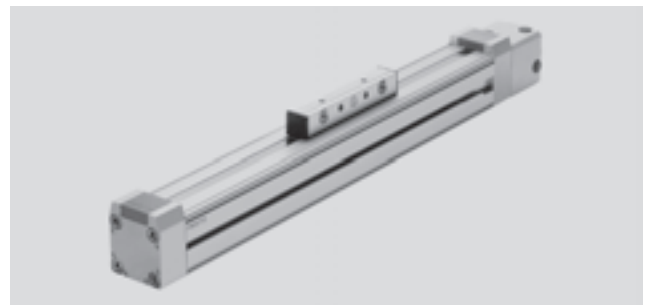

 www.festo.com



-  Size  
18 ... 63
-  Stroke length  
100 ... 2000 mm

General technical data					
Size		18	25	40	63
Constructional design		Electromechanical axis with spindle and driver			
Guide		-			
Mounting position		Any			
Max. working stroke <sup>1)</sup>	[mm]	100 ... 500	100 ... 1000 <sup>4)</sup>	200 ... 1500 <sup>4)</sup>	300 ... 2000 <sup>4)</sup>
Max. feed force $F_x$	[N]	140	250	600	1600
Max. driving torque	[Nm]	0.1	0.45	2.1	8.5
Max. no-load driving torque	[Nm]	0.04 <sup>2)</sup>	0.15 <sup>3)</sup>	0.33 <sup>3)</sup>	1.15 <sup>3)</sup>
Max. radial force <sup>4)</sup>	[N]	40	75	250	800
Max. speed <sup>5)</sup>	[m/s]	0.2	0.5	1	1.2
Max. acceleration	[m/s <sup>2</sup> ]	6			
Repetition accuracy	[mm]	±0.02			

- 1) Total stroke = working stroke + 2x stroke reserve
- 2) Measured at a speed of 0.05 m/s
- 3) Measured at a speed of 0.2 m/s
- 4) On drive shaft
- 5) The maximum speed is dependent on the stroke length → 13

Operating and environmental conditions					
Size		18	25	40	63
Ambient temperature	[°C]	0 ... +40			
Protection class		IP40			

Weights [kg]					
Size		18	25	40	63
Basic weight with 0 mm stroke <sup>1)</sup>		0.55	1.4	4.3	12.5
Additional weight per 100 mm stroke		0.21	0.41	0.71	2.53
Moving load		0,13	0,25	0,67	2,17

- 1) Including coupling housing

Mass moment of inertia					
Size		18	25	40	63
$J_0$	[kg cm <sup>2</sup> ]	0.007	0.029	0.364	3.15
$J_H$ per metre stroke	[kg cm <sup>2</sup> /m]	0.031	0.121	1	6.67
$J_L$ per kg working load	[kg cm <sup>2</sup> /kg]	0.005	0.025	0.101	0.228

The mass moment of inertia  $J_A$  of the entire axis is calculated as follows:

$$J_A = J_0 + J_H \times \text{working stroke [m]} + J_L \times m_{\text{working load [kg]}}$$

# Spindle axes DGE-SP

Technical data

FESTO

Spindle					
Size		18	25	40	63
Diameter	[mm]	8	12	20	32
Pitch	[mm/rev.]	4	10	20	30

## Materials

Sectional view

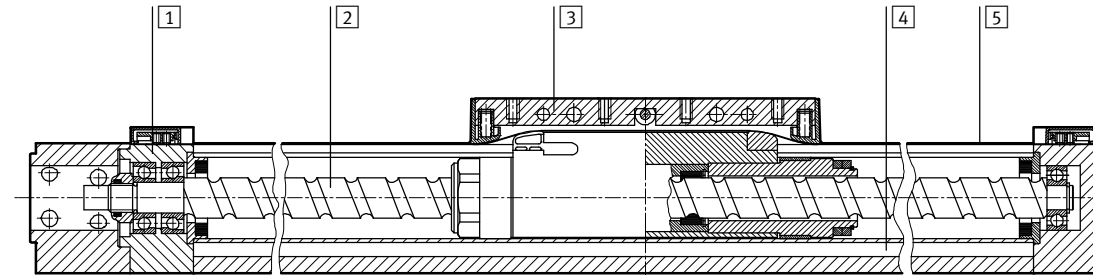

Axis		
1	End cap	Wrought aluminium alloy, anodised
2	Spindle	Rolled steel
3	Driver	Wrought aluminium alloy, anodised
4	Profile	Wrought aluminium alloy, anodised
5	Cover strip	Corrosion resistant steel

## Stroke reserve

L1+ Overall length of axis  
L11 Internal mechanical stop

1 The working stroke is the effective usable work range. Please quote this in your order.

L12 Stroke reserve:  
Safety distance to mechanical stop, present at both ends of the axis in addition to the stroke.

Example:  
Type DGE-25-500-SP  
Working stroke = 500 mm  
Stroke reserve = (2x 10 mm)  
= 20 mm  
Total stroke  
520 mm = 500 mm + 20 mm

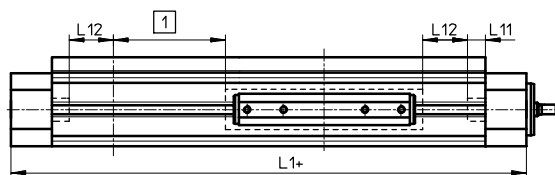

Size		18	25	40	63
L12 per end position	[mm]	6.5	10	20	30

# Spindle axes DGE-SP

Technical data

## Characteristic load values

The indicated forces and torques refer to the centre line of the internal diameter of the profile.

They must not be exceeded in the dynamic range. Special attention must be paid to the cushioning phase.

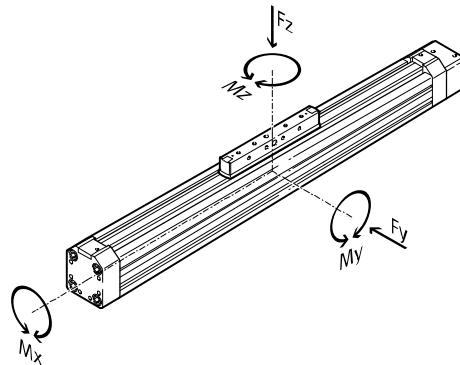

If the axis is subjected to more than two of the indicated forces and torques simultaneously, the following equations must be satisfied in addition to the indicated maximum loads:

$$\frac{Fz}{Fz_{max.}} + \frac{My}{My_{max.}} + \frac{Mz}{Mz_{max.}} \leq 1$$

$$\frac{Mx}{Mx_{max.}} \leq 1$$

Permissible forces and torques					
Size		18	25	40	63
Fy <sub>max.</sub>	[N]	–	–	–	–
Fz <sub>max.</sub>	[N]	1.8	2	15	106
Mx <sub>max.</sub>	[Nm]	0.5	1	4	8
My <sub>max.</sub>	[Nm]	0.8	1.5	4	18
Mz <sub>max.</sub>	[Nm]	0.8	1.5	4	18

## 2nd moment of area

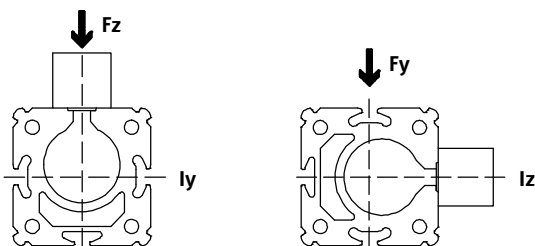

Size		18	25	40	63
Iy	[mm <sup>4</sup> ]	69.8x10 <sup>3</sup>	224x10 <sup>3</sup>	673x10 <sup>3</sup>	5688x10 <sup>3</sup>
Iz	[mm <sup>4</sup> ]	72.3x10 <sup>3</sup>	240x10 <sup>3</sup>	748x10 <sup>3</sup>	6031x10 <sup>3</sup>

 Note  
 Sizing software  
 PositioningDrives  
[www.festo.com](http://www.festo.com)

# Spindle axes DGE-SP

Technical data

## Maximum permissible support span $l$ as a function of the force $F$

The axis may need to be supported with central supports in order to restrict deflection with long stroke lengths. The following diagrams serve to determine the maximum permissible support span  $l$  as a function of the force acting upon the axis  $F$ .

### 1 Force on the surface of the driver

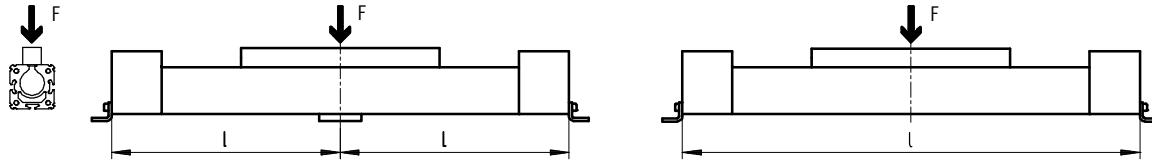

### 2 Force on the front of the driver

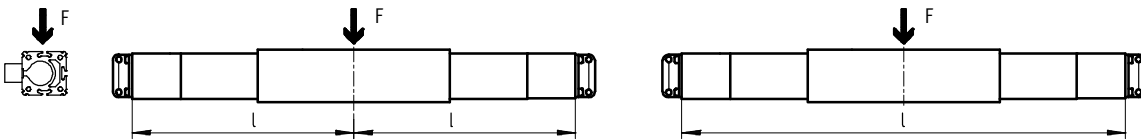

## Maximum permissible support span $l$ (without central support) as a function of the force $F$

DGE-18

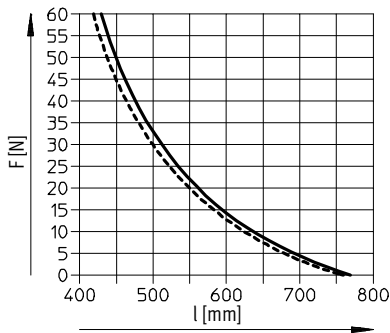

DGE-25

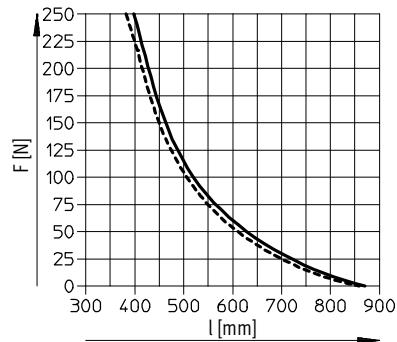

DGE-40

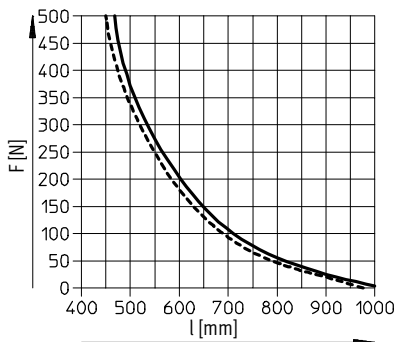

DGE-63

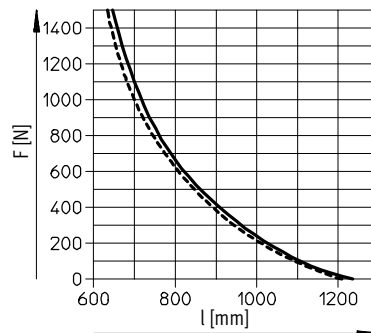

— 1  
- - - 2

# Spindle axes DGE-SP

Technical data

## Maximum permissible speed $v$ or drive rpm $n$ as a function of the stroke $l$

DGE-18

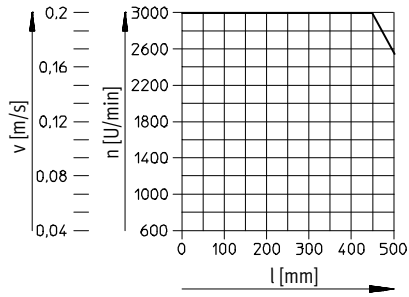

DGE-25

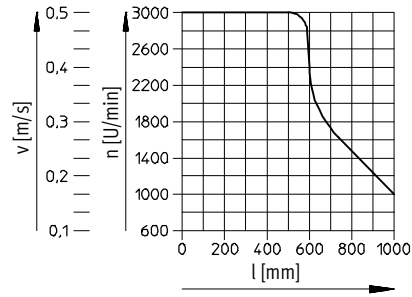

DGE-40

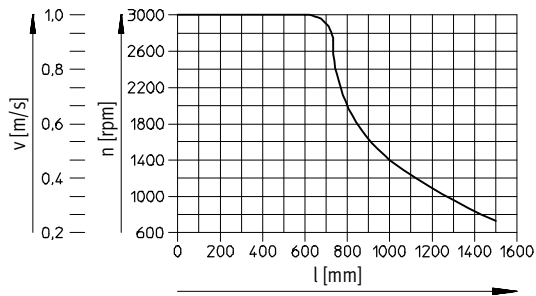

DGE-63

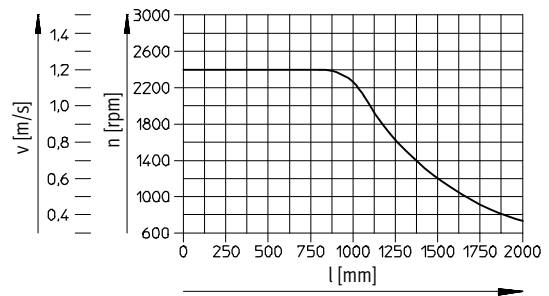

# Spindle axes DGE-SP

Technical data

FESTO

## Dimensions

Download CAD data → [www.festo.com](http://www.festo.com)

### Size 18

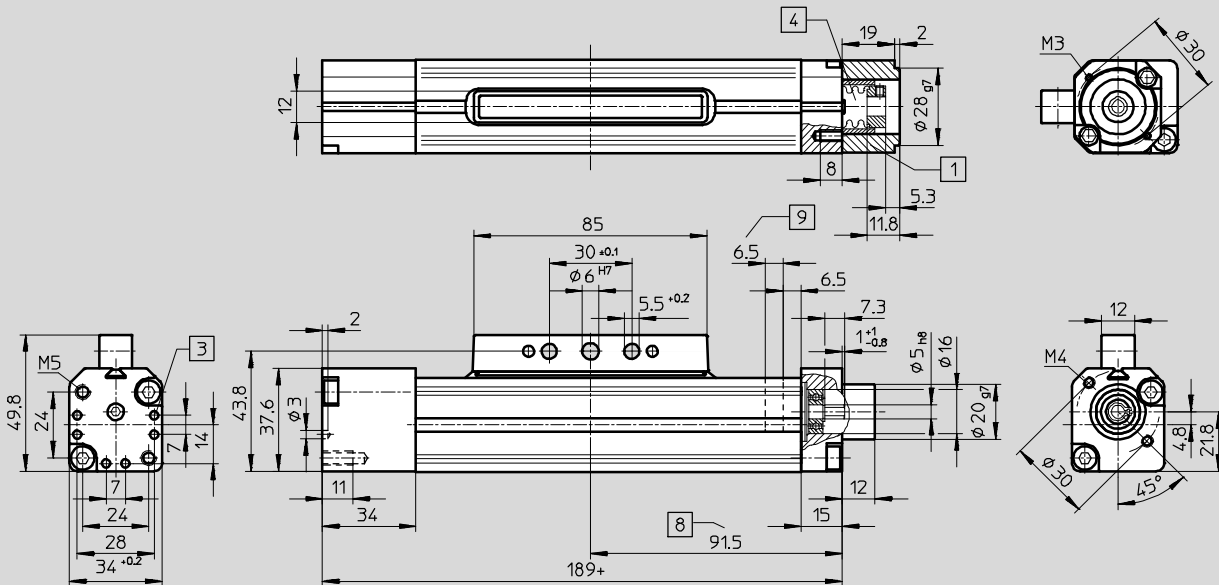

- 1 Coupling housing
- 2 Sensor slot for proximity sensor
- 3 Centring hole for foot mounting HP
- 4 Coupling
- 5 Stroke reserve → 10
- 6 Mounting slot for slot nut NST
- 7 + = plus stroke length
- 8 Driver in end position of working stroke (stroke reserve up to mechanical stop still present)

## Profile

### Size 18

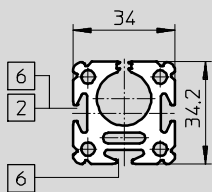

- 2 Sensor slot for proximity sensor
- 6 Mounting slot for slot nut NST

# Spindle axes DGE-SP

Technical data

## Dimensions

Download CAD data → [www.festo.com](http://www.festo.com)

### Size 25 ... 63

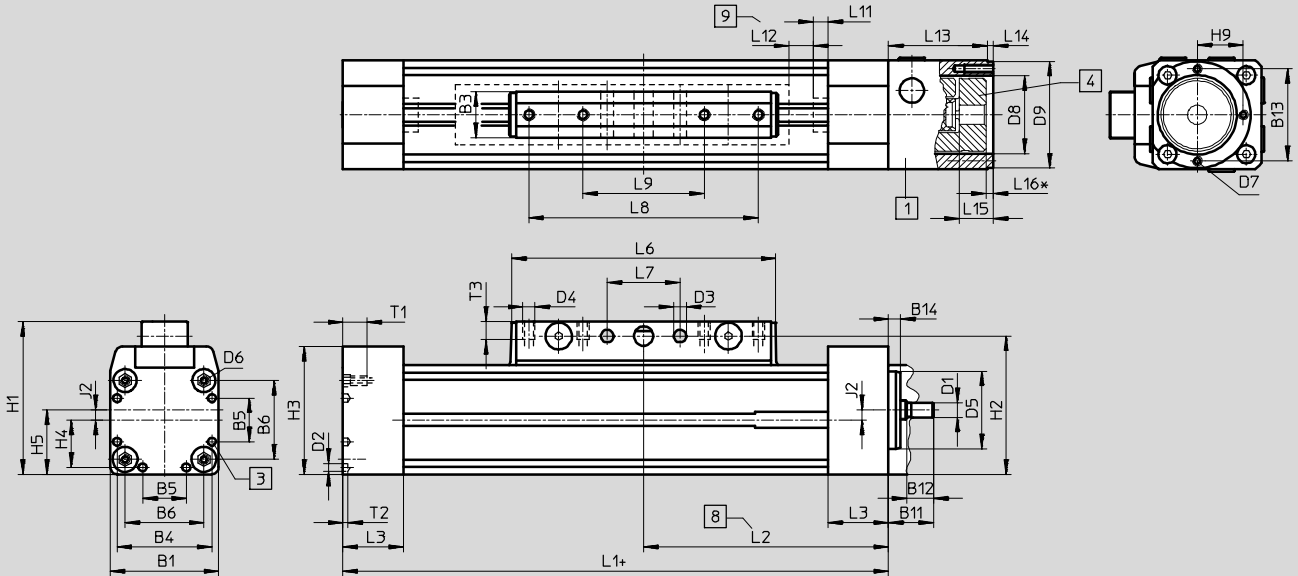

- 1 Coupling housing
  - 3 Centring hole for foot mounting HP
  - 4 Coupling
  - 8 Driver in end position of working stroke (stroke reserve up to mechanical stop still present)
  - 9 Stroke reserve → 10
- + = plus stroke length

## Profile

### Size 25

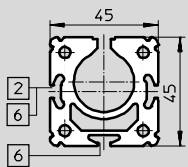

### Size 40

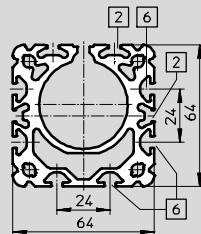

### Size 63

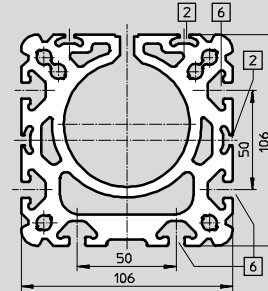

- 2 Sensor slot for proximity sensor
- 6 Mounting slot for slot nut NST

Size	B1	B3	B4	B5	B6	B11	B12	B13	B14	D1	D2	D3	D4	D5	D6	D7	D8	D9	H1	H2	H3
25	45	19 +0.2	39.1	18	32.5	18.5	11	38	4	6	3.3	5.2	M5	32	M4	M4	32	44	63	57	52.8
40	64	21	53	28	49	22.5	12	38	5	12	4.4	6.5	M6	48	M5	M4	32	44	86	78	71.8
63	106	24	89	44	83	47.5	25	56	7	20	6.4	8.5	M8	72	M8	M6	48	64	131	122	115

Size	H4	H5	H9	J2	L1	L2	L3	L6	L7	L8	L9	L11	L12	L13	L14	L15	L16 <sup>1)</sup>	T1	T2	T3	
25	19.6	26.5	19	4	213	101.5	25	109	30	±0.1	±0.1	±0.1	6	10	43	2.5	14	3	13	2	7.5
40	26.5	37	19	5	315	153	31	171	70	130	40	7	20	46	3	14.5	3.5	13	3	10.5	
63	44.5	61	28	8	410	200	36	234	110	190	70	9	30	83	4	23	-2	21	4	12.5	

1) Negative dimension: Protrudes beyond coupling housing

# Spindle axes DGE-SP

Ordering data – Modular products

**Order code**

Mandatory data

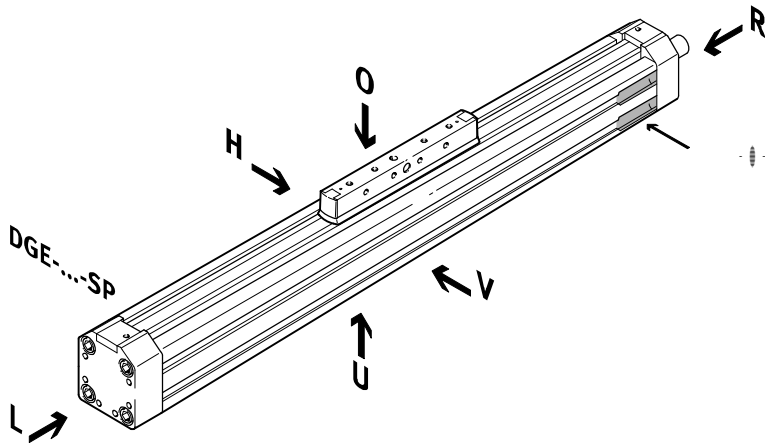

-  - Note

The insertion point for the proximity sensor is located on the right-hand side of the spindle axis DGE-...-SP

- O top
- U underneath
- V front
- H rear
- R right
- L left



# Spindle axes DGE-SP

Ordering data – Modular products

## Order code

Options

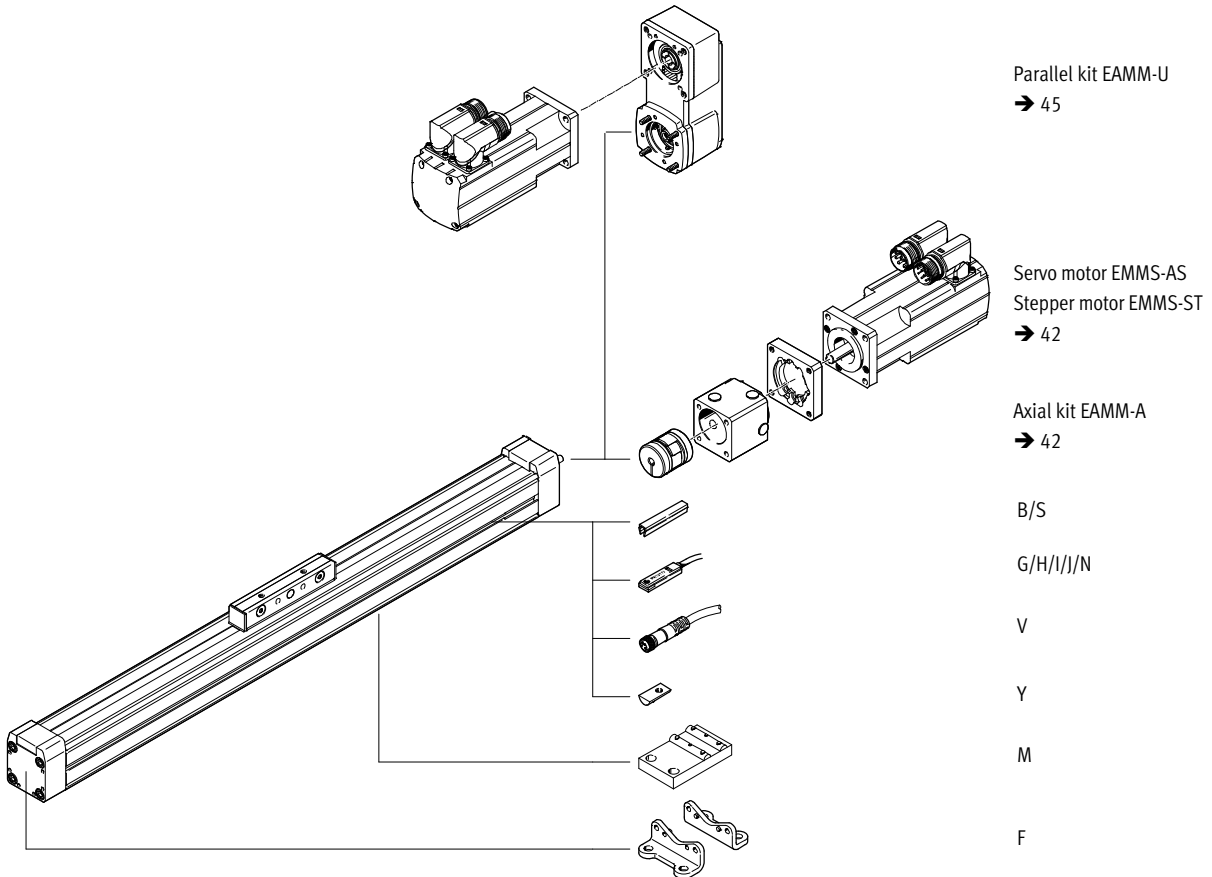

# Spindle axes DGE-SP

Ordering data – Modular products



**M** Mandatory data →

Module No.	Design	Size	Stroke	Drive function
193745	DGE	18	1 ... 2000	SP
193746		25		
193747		40		
193748		63		
<b>Ordering example</b>				
<b>193747</b>	<b>DGE</b>	<b>40</b>	<b>800</b>	<b>SP</b>

**Ordering table**

Size	18	25	40	63	Condi- tions	Code	Enter code
<b>M</b> Module No.	<b>193745</b>	<b>193746</b>	<b>193747</b>	<b>193748</b>			
Design	Electromechanical linear axis					<b>DGE</b>	DGE
Size	18	25	40	63		-...	
Stroke [mm]	100, 200, 300, 400, 500	100, 200, 300, 400, 500, 600, 700, 800, 900, 1000	200, 300, 400, 500, 600, 800, 1000, 1200, 1400, 1500	300, 400, 500, 600, 800, 1000, 1200, 1400, 1500, 1800, 2000		-...	
	-	1 ... 990	1 ... 1487	1 ... 1982			
Drive function	Electromechanical drive with ball screw					<b>-SP</b>	-SP

Transfer order code

	<b>DGE</b>	-		-		-	<b>SP</b>
--	------------	---	--	---	--	---	-----------

# Spindle axes DGE-SP

Ordering data – Modular products



Options						
Accessories	Slot cover	Slot nut	Central support	Foot mounting	Proximity sensor	Plug socket
ZUB	...S ...B	...Y	...M	...F	...G ...H ...I ...J ...N	...V
ZUB	– 2S2B	10Y		F	2G	

Ordering table								
Size	18	25	40	63	Condi- tions	Code	Enter code	
↓ Accessories	Supplied separately						ZUB-	ZUB-
0 Slot cover	Sensor slot	1 ... 10				...S		
	Mounting slot	–	–	1 ... 10		...B		
	Slot nut for mounting slot	1 ... 10				...Y		
	Central support	1 ... 10				...M		
	Foot mounting (kit)	1 ... 10				...F		
	Proximity sensor with cable, 2.5 m	1 ... 10				...G		
	with plug	1 ... 10				...H		
	contactless with cable, 2.5 m	1 ... 10				...I		
	contactless, plug	1 ... 10				...J		
	NC contact with cable, 2.5 m	1 ... 10				...N		
	Cable with socket, 2.5 m	1 ... 10				...V		

Transfer order code

ZUB –

# Spindle axes DGE-SP-KF, with recirculating ball bearing guide

Peripherals overview

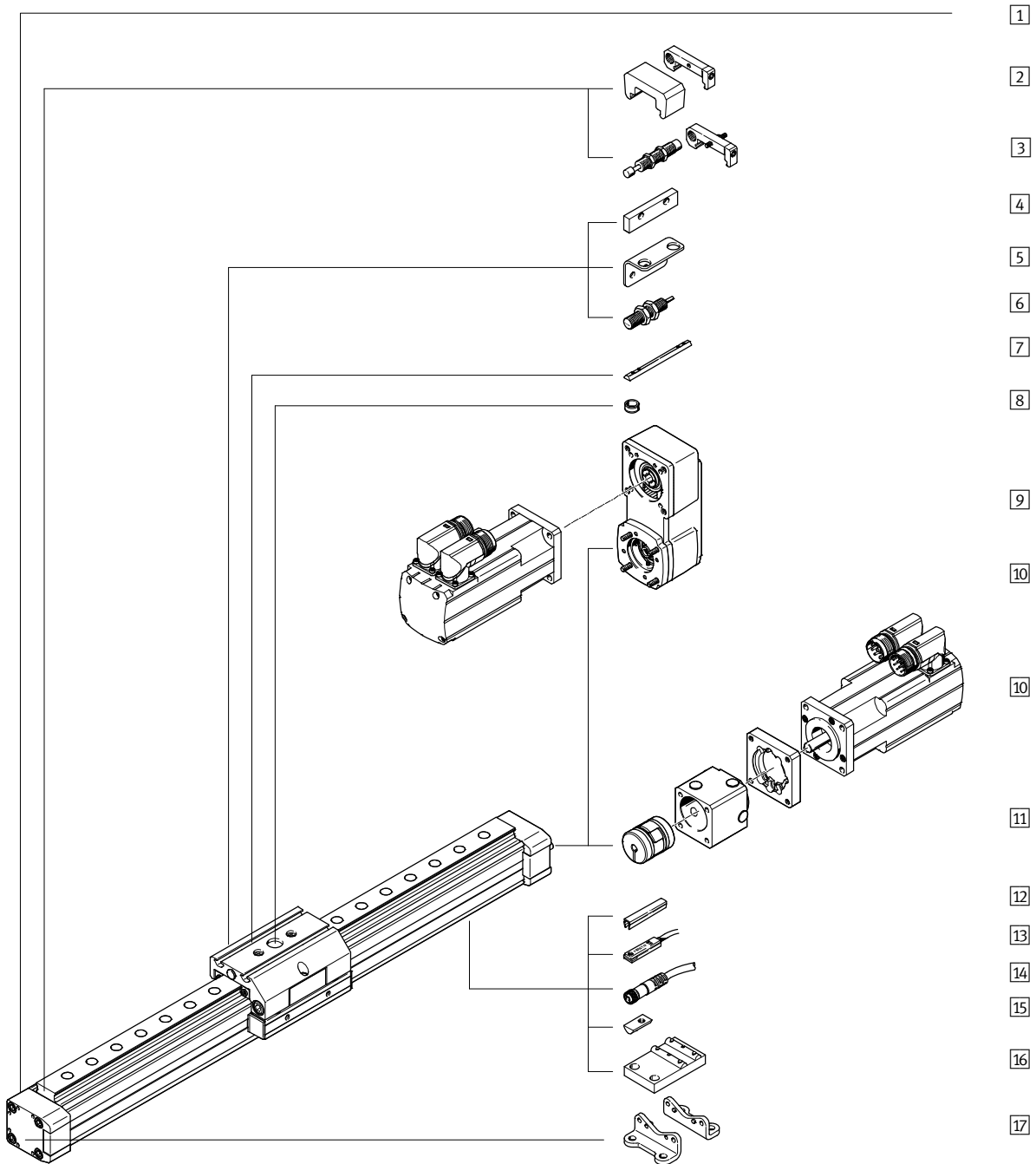
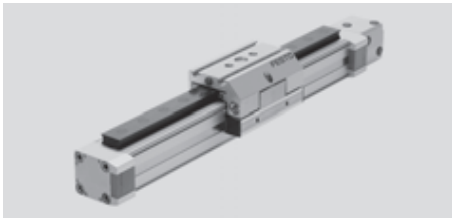

# Spindle axes DGE-SP-KF, with recirculating ball bearing guide

Peripherals overview

Variants and accessories				
Type	Description	GK/GV	GA	→ Page/Internet
1 Spindle axis DGE-SP-KF	Electromechanical axis with spindle and recirculating ball bearing guide	■	■	22
2 Emergency buffer with retainer <sup>1)</sup> A	For avoiding damage at the end stop in the event of malfunction	■	■	48
3 Shock absorber kit C	For avoiding damage at the end stop in the event of malfunction	■	–	47
3 Shock absorber kit E	For avoiding damage at the end stop in the event of malfunction	–	■	48
4 Switching lug L	For sensing the slide position	■	–	49
5 Sensor bracket T	Adapter for mounting the inductive proximity sensors on the axis	■	–	49
6 Inductive proximity sensor O/P/R/W	For use as a signal generator and safety monitoring	■	–	52
7 Slot nut for slide X	For mounting loads and attachments on the slide	■	■	51
8 Centring pins/sleeves Z	For centring loads and attachments on the slide	■	■	51
9 Parallel kit EAMM-U	For parallel motor attachment (consisting of: housing, Clamping component, clamping sleeve, toothed belt gearwheel, toothed belt)	■	■	45
10 Motor EMMS	Motors specially matched to the axis, with or without gearing, with or without brake	■	■	42
11 Axial kit EAMM-A	For axial motor attachment (consisting of: coupling housing, clamping component, motor flange)	■	■	42
12 Slot cover B/S	For protecting against the ingress of dirt	■	■	51
13 Proximity sensor G/H/I/J/N	For use as a signal or safety check	■	■	52
14 Cable with socket V	For proximity sensors	■	■	52
15 Slot nut for mounting slot Y	For mounting attachments	■	■	51
16 Central support M	For mounting the axis	■	■	46
17 Foot mounting F	For mounting the axis	■	■	46

1) Fitted as standard for GV and GA.

# Spindle axes DGE-SP-KF, with recirculating ball bearing guide

Type code

DGE - 25 - 500 - SP - KF - GK - SV -

**Type**

DGE	Spindle axis
-----	--------------

**Size**

**Stroke [mm]**

**Drive function**

SP	Spindle
----	---------

**Guide**

KF	Recirculating ball bearing guide
----	----------------------------------

**Slide**

GK	Standard slide
GV	Extended slide
GA	Protected version

**Slide attachment position**

SV	At front
SH	At rear

**Additional slide**

KL	Left
KR	Right

# Spindle axes DGE-SP-KF, with recirculating ball bearing guide

Type code

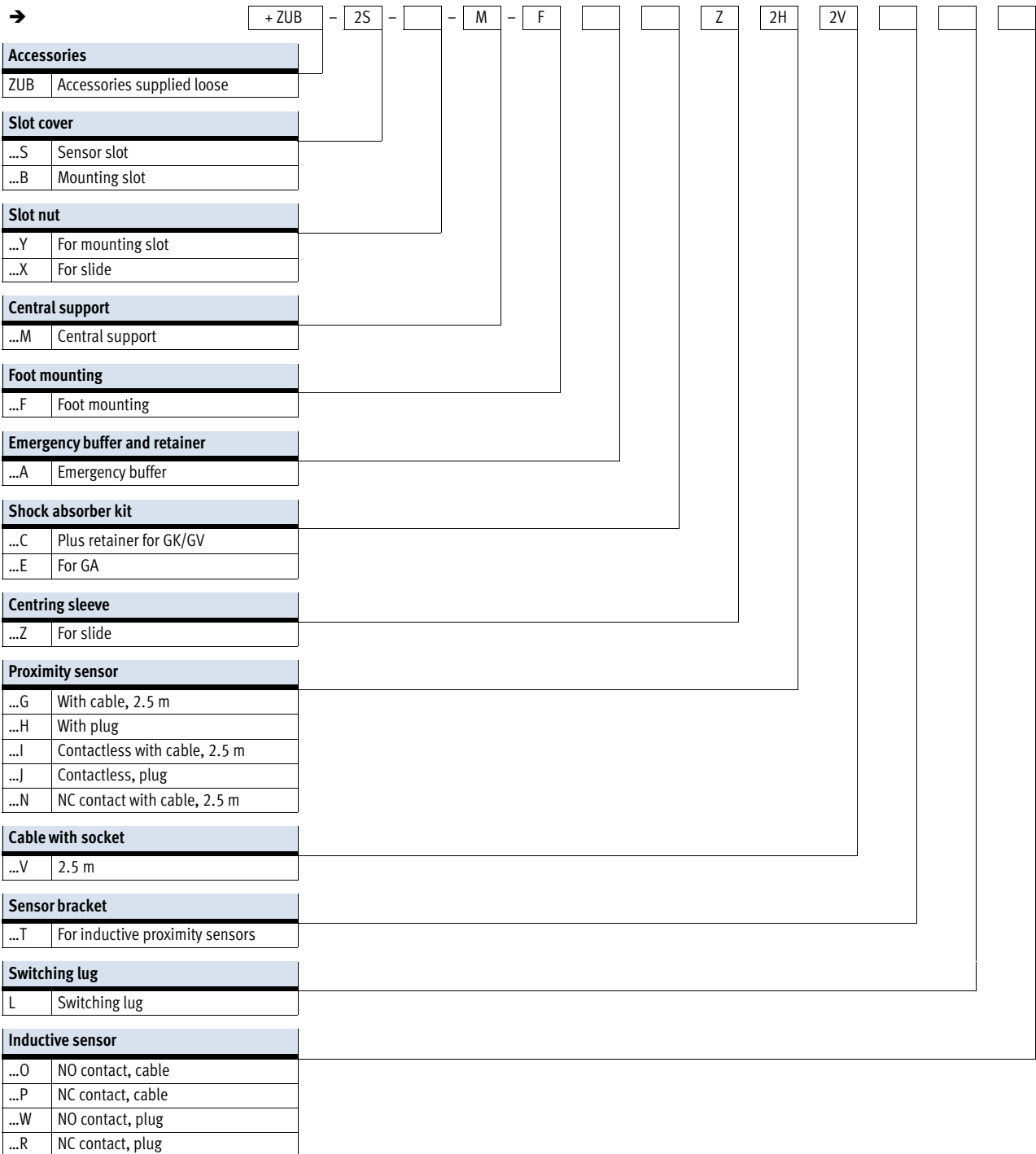

# Spindle axes DGE-SP-KF, with recirculating ball bearing guide

FESTO

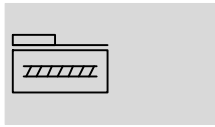

Technical data

Function

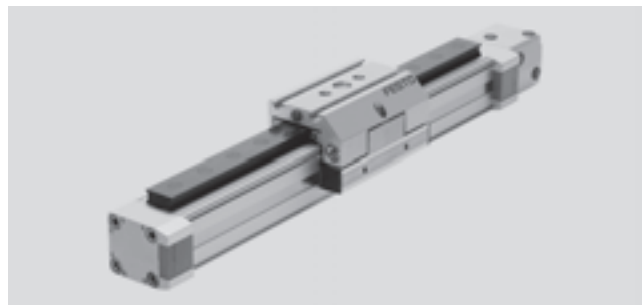

 [www.festo.com](http://www.festo.com)



-  Size  
18 ... 63
-  Stroke length  
100 ... 2000 mm

General technical data			18	25	40	63
Size			18	25	40	63
Constructional design			Electromechanical axis with spindle and recirculating ball bearing guide			
Guide			Recirculating ball bearing guide			
Mounting position			Any			
Max. working stroke <sup>1)</sup>	GK	[mm]	100 ... 500	100 ... 1000 <sup>4)</sup>	200 ... 1500 <sup>4)</sup>	300 ... 2000 <sup>4)</sup>
	GV	[mm]	110 ... 410	170 ... 870 <sup>4)</sup>	170 ... 1270 <sup>4)</sup>	150 ... 1650 <sup>4)</sup>
	GA	[mm]	–	170 ... 970 <sup>4)</sup>	140 ... 1440 <sup>4)</sup>	–
Max. working load		[kg]	6	25	50	150
Max. feed force $F_x$		[N]	140	250	600	1600
Max. driving torque		[Nm]	0.1	0.45	2.1	8.5
Max. no-load driving torque		[Nm]	0.04 <sup>2)</sup>	0.15 <sup>3)</sup>	0.33 <sup>3)</sup>	1.15 <sup>3)</sup>
Max. radial force <sup>4)</sup>		[N]	40	75	250	800
Max. speed <sup>5)</sup>		[m/s]	0.2	0.5	1	1.2
Max. acceleration		[m/s <sup>2</sup> ]	6			
Repetition accuracy		[mm]	±0.02			

- 1) Total stroke = working stroke + 2x stroke reserve → 28
- 2) Measured at a speed of 0.05 m/s
- 3) Measured at a speed of 0.2 m/s
- 4) On drive shaft
- 5) The maximum speed is dependent on the stroke length → 30

Operating and environmental conditions			18	25	40	63
Size			18	25	40	63
Ambient temperature		[°C]	0 ... +40			
Protection class			IP40			

Weights [kg]			18	25	40	63
Size			18	25	40	63
Basic weight with 0 mm stroke <sup>1)</sup>	GK		1	2.1	6.4	18.1
	GV		1.52	3.26	10.04	32.2
	GA		–	3.1	8.97	–
Additional weight per 100 mm stroke	GK		0.3	0.56	1.14	3.31
	GV		0.3	0.56	1.14	3.31
	GA		–	0.65	1.26	–
Moving load	GK		0,45	0,68	1,82	5,38
	GV		0,61	0,94	2,54	7,84
	GA		–	1,24	3,19	–
Additional slide		KL/KR	0.25	0.38	1.06	3.1

- 1) Including coupling housing and slide



# Spindle axes DGE-SP-KF, with recirculating ball bearing guide

Technical data

Mass moment of inertia			18	25	40	63
Size						
$J_0$	GK	[kg cm <sup>2</sup> ]	0.008	0.04	0.48	3.88
	GV	[kg cm <sup>2</sup> ]	0.0117	0.0617	0.782	6.77
	GA	[kg cm <sup>2</sup> ]	–	0.0573	0.678	–
$J_H$ per metre stroke		[kg cm <sup>2</sup> /m]	0.031	0.121	1	6.67
$J_L$ per kg working load		[kg cm <sup>2</sup> /kg]	0.005	0.025	0.101	0.228
$J_W$ for additional slide		[kg cm <sup>2</sup> ]	0.001	0.0096	0.107	0.707

The mass moment of inertia  $J_A$  of the entire axis is calculated as follows:

$$J_A = J_0 + J_H \times \text{working stroke [m]} + J_L \times m_{\text{working load [kg]}}$$

Spindle					
Size		18	25	40	63
Diameter	[mm]	8	12	20	32
Pitch	[mm/rev.]	4	10	20	30

## Materials

Sectional view

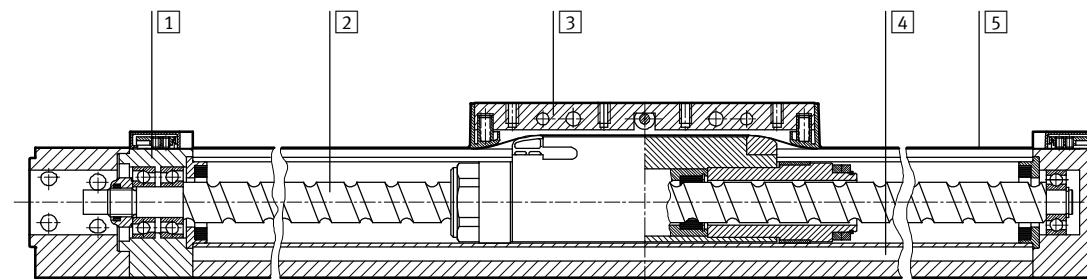

Axis		
1	End cap	Wrought aluminium alloy, anodised
2	Spindle	Rolled steel
3	Slide	Wrought aluminium alloy, anodised
4	Profile	Wrought aluminium alloy, anodised
5	Cover strip	Corrosion resistant steel

# Spindle axes DGE-SP-KF, with recirculating ball bearing guide

Technical data



## Characteristic load values for axis with standard slide GK or protected version GA

The indicated forces and torques refer to the centre of the guide rail. They must not be exceeded in the dynamic range. Special attention must be paid to the cushioning phase.

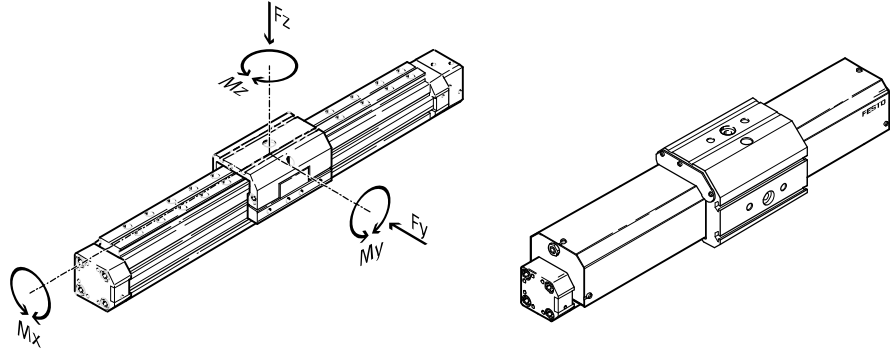

If the drive is subjected to more than two of the indicated forces and torques simultaneously, the following equations must be satisfied in addition to the indicated maximum loads:

$$\frac{F_y}{F_{y_{max}}} + \frac{F_z}{F_{z_{max}}} + \frac{M_x}{M_{x_{max}}} + \frac{M_y}{M_{y_{max}}} + \frac{M_z}{M_{z_{max}}} \leq 1$$

### Permissible forces and torques GK/-GA

Size		18	25	40	63
F <sub>y</sub> <sub>max.</sub>	[N]	930	3080	7300	14050
F <sub>z</sub> <sub>max.</sub>	[N]	930	3080	7300	14050
M <sub>x</sub> <sub>max.</sub>	[Nm]	7	45	170	580
M <sub>y</sub> <sub>max.</sub>	[Nm]	23	85	330	910
M <sub>z</sub> <sub>max.</sub>	[Nm]	23	85	330	910

### 2nd moment of area

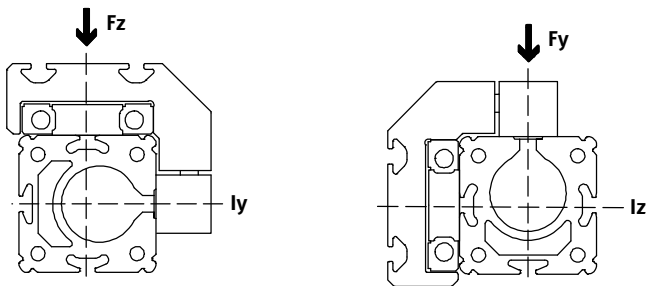

Size		18	25	40	63
l <sub>y</sub>	[mm <sup>4</sup> ]	172.3x10 <sup>3</sup>	551x10 <sup>3</sup>	1908x10 <sup>3</sup>	13677x10 <sup>3</sup>
l <sub>z</sub>	[mm <sup>4</sup> ]	73.7x10 <sup>3</sup>	250x10 <sup>3</sup>	875x10 <sup>3</sup>	6987x10 <sup>3</sup>

- - Note  
Sizing software  
PositioningDrives  
→ [www.festo.com](http://www.festo.com)

# Spindle axes DGE-SP-KF, with recirculating ball bearing guide

Technical data

## Characteristic load values for axis with extended slide GV

The indicated forces and torques refer to the centre of the guide rail. They must not be exceeded in the dynamic range. Special attention must be paid to the cushioning phase.

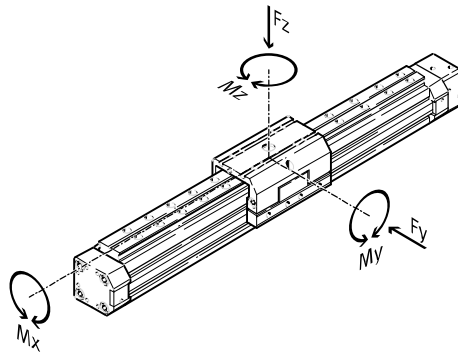

If the drive is subjected to more than two of the indicated forces and torques simultaneously, the following equations must be satisfied in addition to the indicated maximum loads:

$$\frac{F_y}{F_{y_{max}}} + \frac{F_z}{F_{z_{max}}} + \frac{M_x}{M_{x_{max}}} + \frac{M_y}{M_{y_{max}}} + \frac{M_z}{M_{z_{max}}} \leq 1$$

Permissible forces and torques					
Size		18	25	40	63
F <sub>y<sub>max.</sub></sub>	[N]	930	3080	7300	14050
F <sub>z<sub>max.</sub></sub>	[N]	930	3080	7300	14050
M <sub>x<sub>max.</sub></sub>	[Nm]	7	45	170	580
M <sub>y<sub>max.</sub></sub>	[Nm]	45	170	660	1820
M <sub>z<sub>max.</sub></sub>	[Nm]	45	170	660	1820

## 2nd moment of area

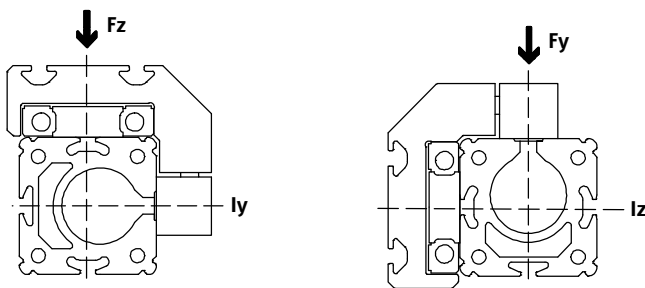

Size		18	25	40	63
I <sub>y</sub>	[mm <sup>4</sup> ]	172.3x10 <sup>3</sup>	551x10 <sup>3</sup>	1908x10 <sup>3</sup>	13677x10 <sup>3</sup>
I <sub>z</sub>	[mm <sup>4</sup> ]	73.7x10 <sup>3</sup>	250x10 <sup>3</sup>	875x10 <sup>3</sup>	6987x10 <sup>3</sup>

# Spindle axes DGE-SP-KF, with recirculating ball bearing guide

Technical data



## Stroke reserve

- L11 Internal mechanical stop
- L1+ Overall length of axis
- L17 Slide length

1 The working stroke is the effective usable work range. Please quote this in your order.

L12 The stroke reserve is a safety distance available on both sides of the axis in addition to the stroke.

Example:  
 Type DGE-25-500-SP  
 Working stroke = 500 mm  
 Stroke reserve = (2x 10 mm)  
 = 20 mm  
 Total stroke:  
 520 mm = 500 mm + 20 mm

### for standard slide GK

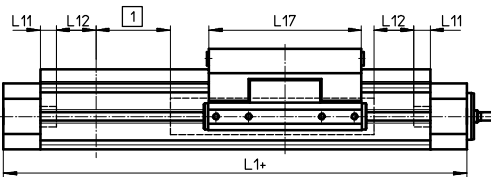

### for extended slide GV

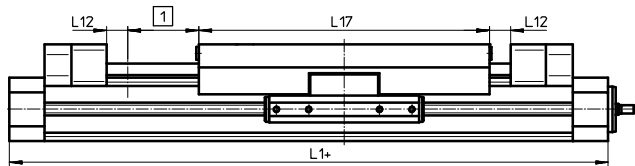

### for protected version GA

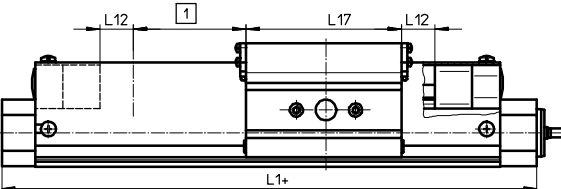

### Stroke reserve L12 [mm] per end position

Size Variant	18	25	40	63
Standard slide GK	6.5	10	20	30
Extended slide GV	3.5	0	1	0
Protected version GA	-	0	1	-

## Working stroke reduction with standard slide GK or extended slide GV and additional slide KL/KR

- L17 = Slide/additional slide length
- L18 = Distance between both slides
- 4 Additional slide

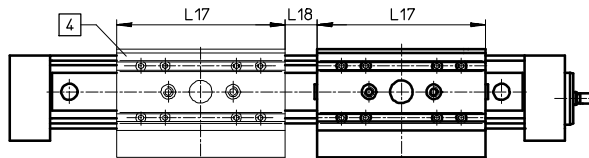

For a spindle axis with additional slide, the working stroke is reduced by the length of the additional slide and the distance between both slides.

Example:  
 Type DGE-25-500-SP-...-KF-GK-KL  
 Working stroke without additional slide = 500 mm  
 L18 = 20 mm  
 L17 = 105 mm  
 Working stroke with additional slide = 375 mm  
 (500 mm - 20 mm - 105 mm)

## Working stroke reduction with standard slide GK with optional emergency buffer

- 2 Reduction of working stroke
- 5 Reduction of working stroke
- 3 Emergency buffer
- 4 Shock absorber retainer
- L12 Stroke reserve

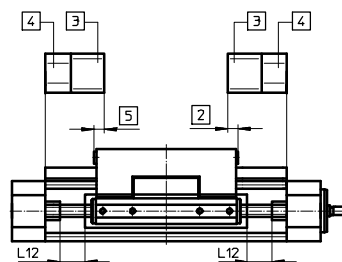

For a spindle axis with optional emergency buffer, the working stroke is reduced, as the stroke reserve is smaller than the overall dimensions of the emergency buffer and shock absorber retainer. The working stroke reduction varies depending on the size of the axis.

		18	25	40	63
2	[mm]	-5	20	33.5	55
5	[mm]	8	10	24.5	45

# Spindle axes DGE-SP-KF, with recirculating ball bearing guide

Technical data

## Maximum permissible support span $l$ as a function of the force $F$

The axis may need to be supported with central supports in order to restrict deflection with long stroke lengths. The following diagrams serve to determine the maximum permissible support span  $l$  as a function of the force acting upon the axis  $F$ .

### 1 Force on the surface of the slide

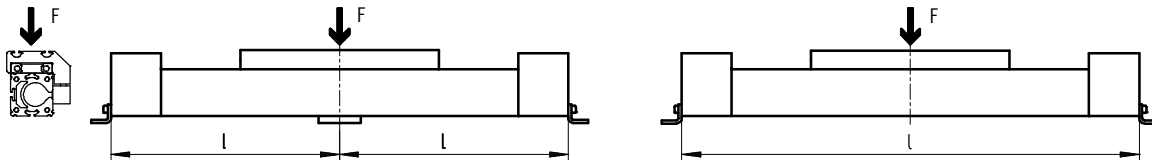

### 2 Force on the front of the slide

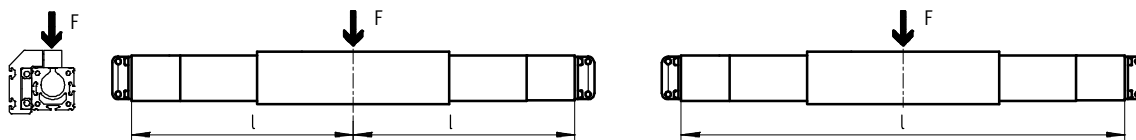

## Maximum permissible support span $l$ (without central support) as a function of the force $F$

DGE-18

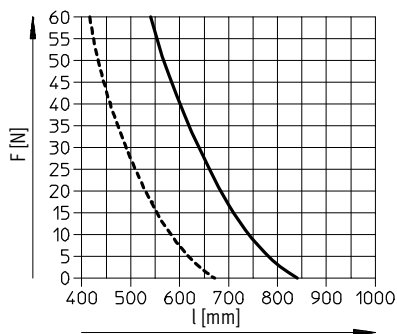

DGE-25

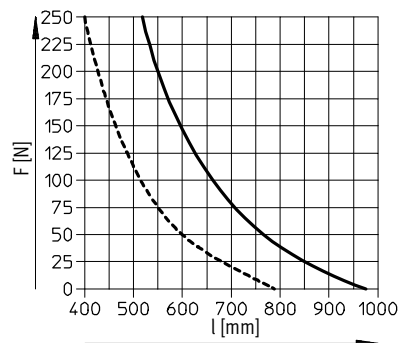

DGE-40

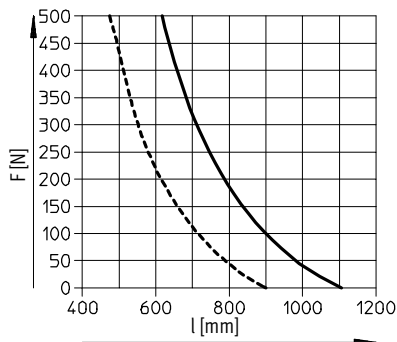

DGE-63

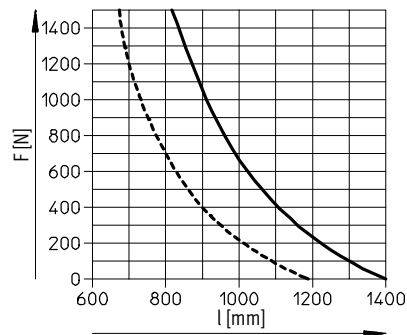

- 1
- - - 2

# Spindle axes DGE-SP-KF, with recirculating ball bearing guide

Technical data

## Maximum permissible speed $v$ or drive rpm $n$ as a function of the stroke $l$

DGE-18

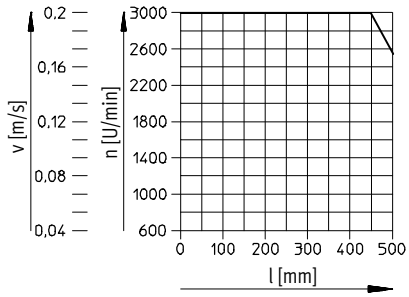

DGE-25

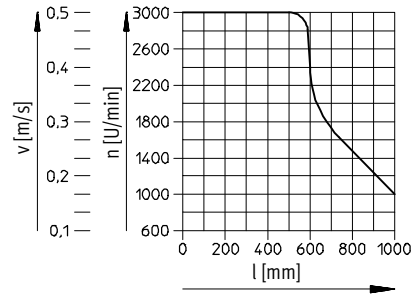

DGE-40

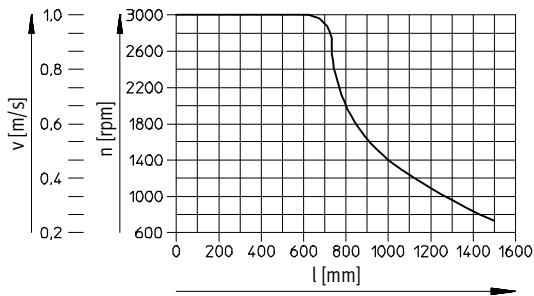

DGE-63

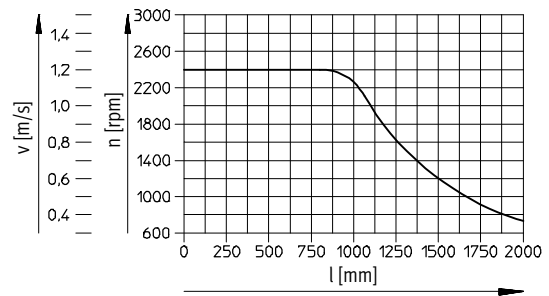

# Spindle axes DGE-SP-KF, with recirculating ball bearing guide

Technical data

FESTO

## Dimensions

Download CAD data → [www.festo.com](http://www.festo.com)

Standard slide GK

Size 18

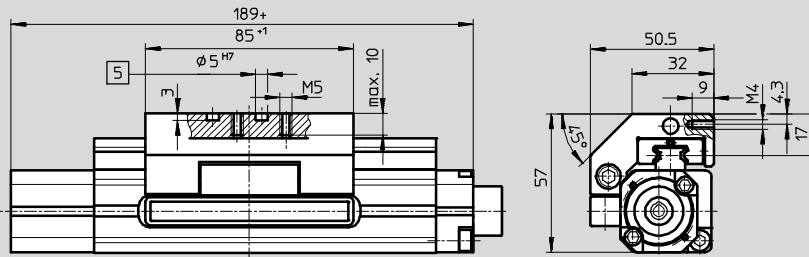

- 5 Hole for centring pin ZBS-5
- + = plus stroke length

Basic dimensions

- 14
- Stroke reserve
- 28

Additional slide KL/KR

Size 18

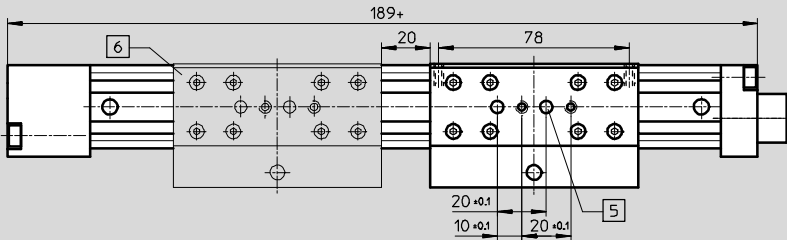

- 5 Hole for centring pin ZBS-5
- 6 Additional slide
- DGE-18-...-KL/KR
- + = plus stroke length

Reduction of working stroke

- 28

Extended slide GV

Size 18

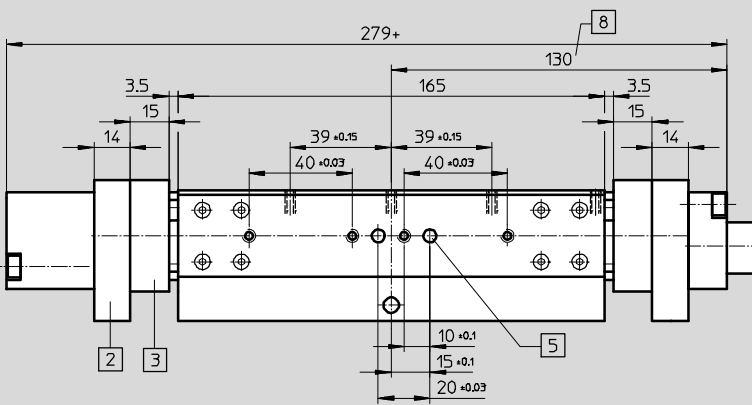

- 2 Shock absorber retainer KYP
- 3 Emergency buffer NPE
- 5 Hole for centring pin ZBS-5
- 8 Driver in end position of working stroke (stroke reserve up to mechanical stop still present)
- + = plus stroke length

Stroke reserve

- 28

Profile

Size 18

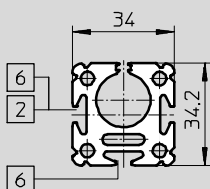

- 2 Sensor slot for proximity sensor
- 6 Mounting slot for slot nut NST

# Spindle axes DGE-SP-KF, with recirculating ball bearing guide

Technical data

FESTO

## Dimensions

Standard slide GK

Download CAD data → [www.festo.com](http://www.festo.com)

### Size 25 ... 63

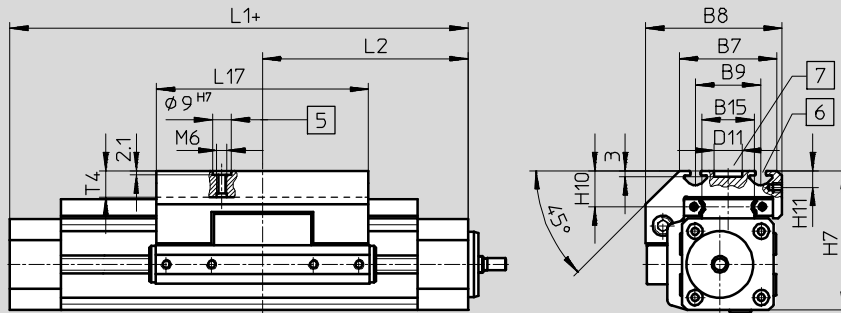

- 5 Hole for centring sleeve ZBH-9
- 6 Mounting slot for slot nut NSTL
- 7 Hole for central mounting SLZZ
- + = plus stroke length

Basic dimensions

→ 15

Stroke reserve

→ 28

### Size 40/63

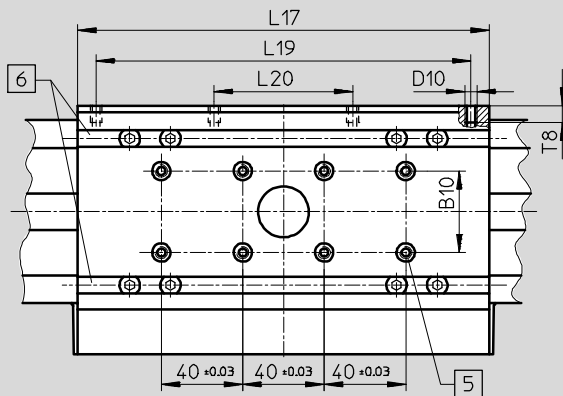

- 5 Hole for centring sleeve ZBH-9
- 6 Mounting slot for slot nut NSTL
- + = plus stroke length

### Size 25 ... 63

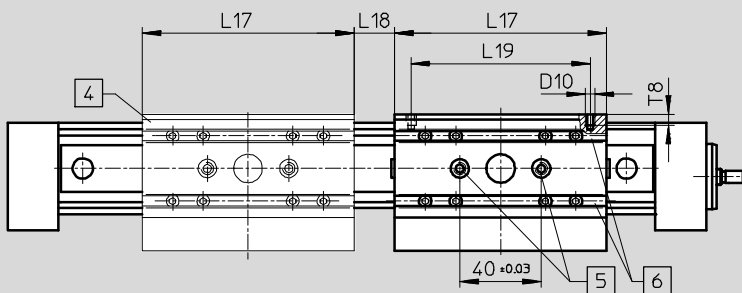

- 4 Additional slide  
DGE-...-...-KL/KR
- 5 Hole for centring sleeve ZBH-9
- 6 Mounting slot for slot nut NSTL
- + = plus stroke length

Reduction of working stroke

→ 28



# Spindle axes DGE-SP-KF, with recirculating ball bearing guide

Technical data

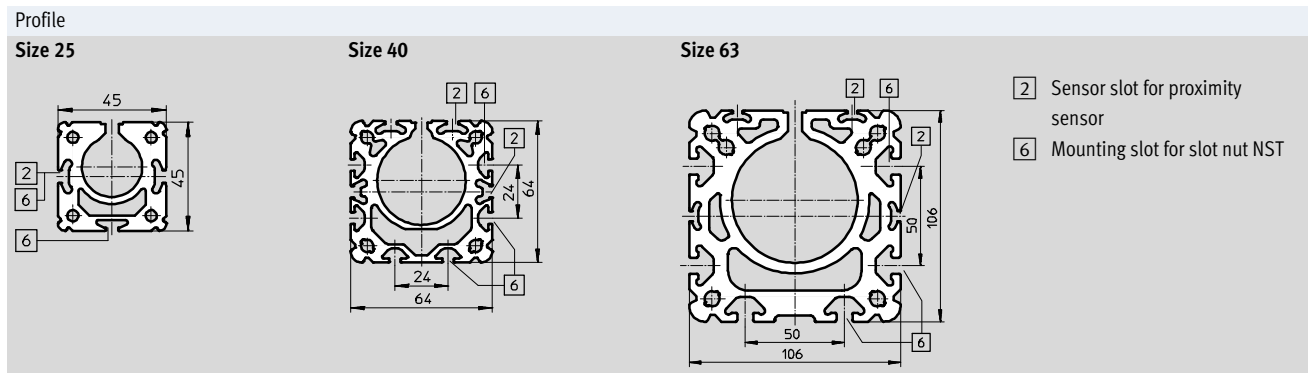

Size	B7	B8	B9 ±0.2	B10	B15	D10	D11 ∅ G7	H7	H10
25	48	67	32	–	23.5	M5	14	68.5	18.5
40	78.5	96.5	55	20	42	M5	25	90.5	20
63	121	142	90	40	71	M8	25	144.5	30

Size	H11	L1	L2	L17	L18 <sup>1)</sup>	L19 ±0.1	L20 ±0.1	T4 max.	T8
25	8.2	213	101.5	105	20	88	–	12.5	8.5
40	7	315	153	167	20	150	58	12.5	8.5
63	12.5	410	200	230	27	200	72	20.5	10.5

1) Recommended minimum distance for access to lubrication nipple

# Spindle axes DGE-SP-KF, with recirculating ball bearing guide

Technical data

FESTO

## Dimensions

Download CAD data → [www.festo.com](http://www.festo.com)

Extended slide GV

### Size 25 ... 63

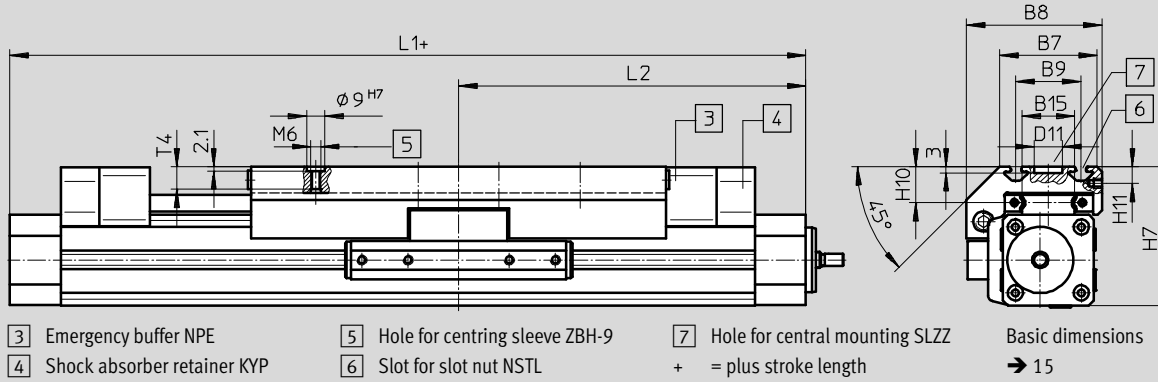

### Size 25

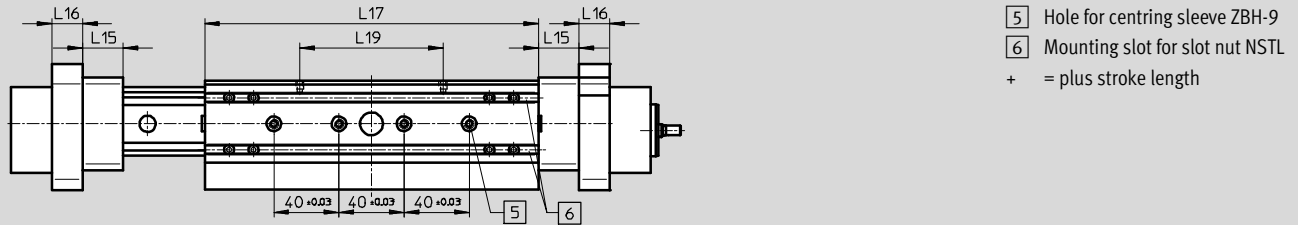

### Size 40/63

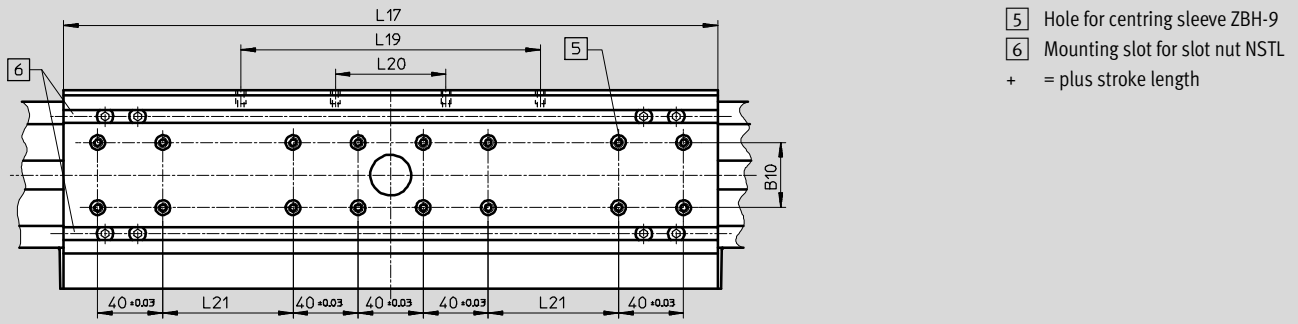

# Spindle axes DGE-SP-KF, with recirculating ball bearing guide

Technical data

Size	B7	B8	B9 ±0.2	B10	B15	D10	D11 ∅ G7	H7	H10	H11
25	48	67	32	–	23.5	M5	14	68.5	18.5	8.2
40	78.5	96.5	55	20	42	M5	25	90.5	20	7
63	121	142	90	40	71	M8	25	144.5	30	12.5

Size	L1	L2	L15	L16	L17 ±0.2	L19 ±0.1	L20 ±0.1	L21 ±0.1	T4 max.	T8
25	343	171.5	25	19	205	88	–	–	12.5	8.5
40	545	271.5	40	32	337	150	58	40	12.5	8.5
63	760	380	60	44	480	200	72	120	20.5	10.5

# Spindle axes DGE-SP-KF, with recirculating ball bearing guide

Technical data

FESTO

## Dimensions

Download CAD data → [www.festo.com](http://www.festo.com)

Protected version GA

### Size 25

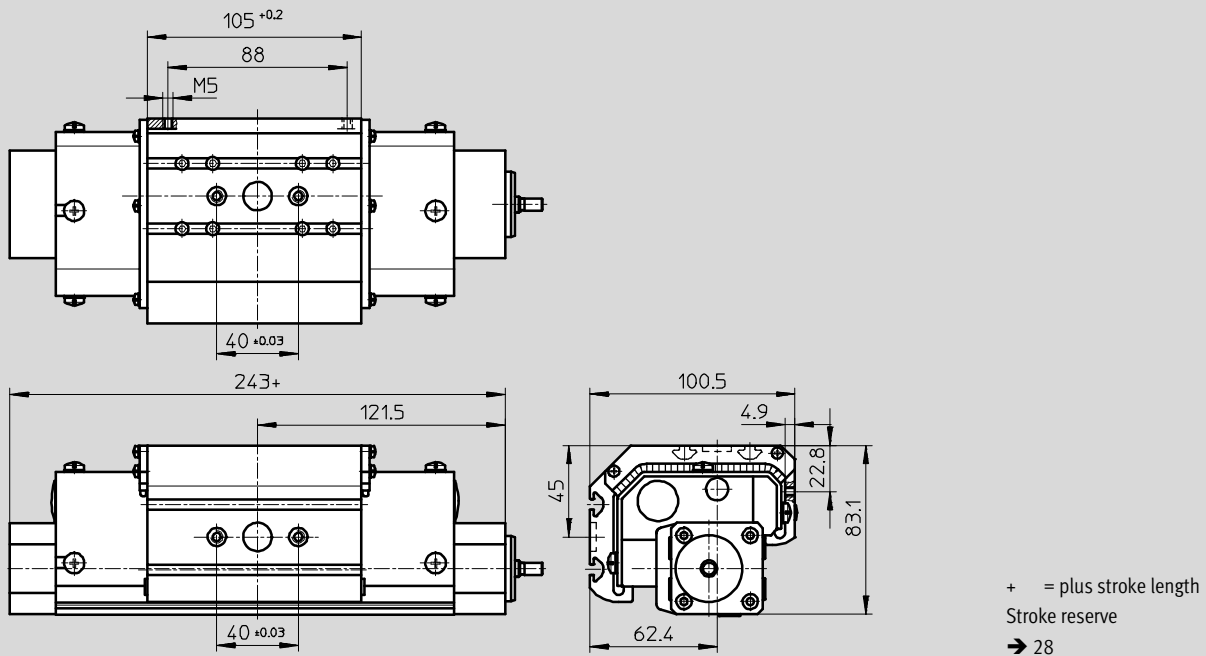

### Size 40

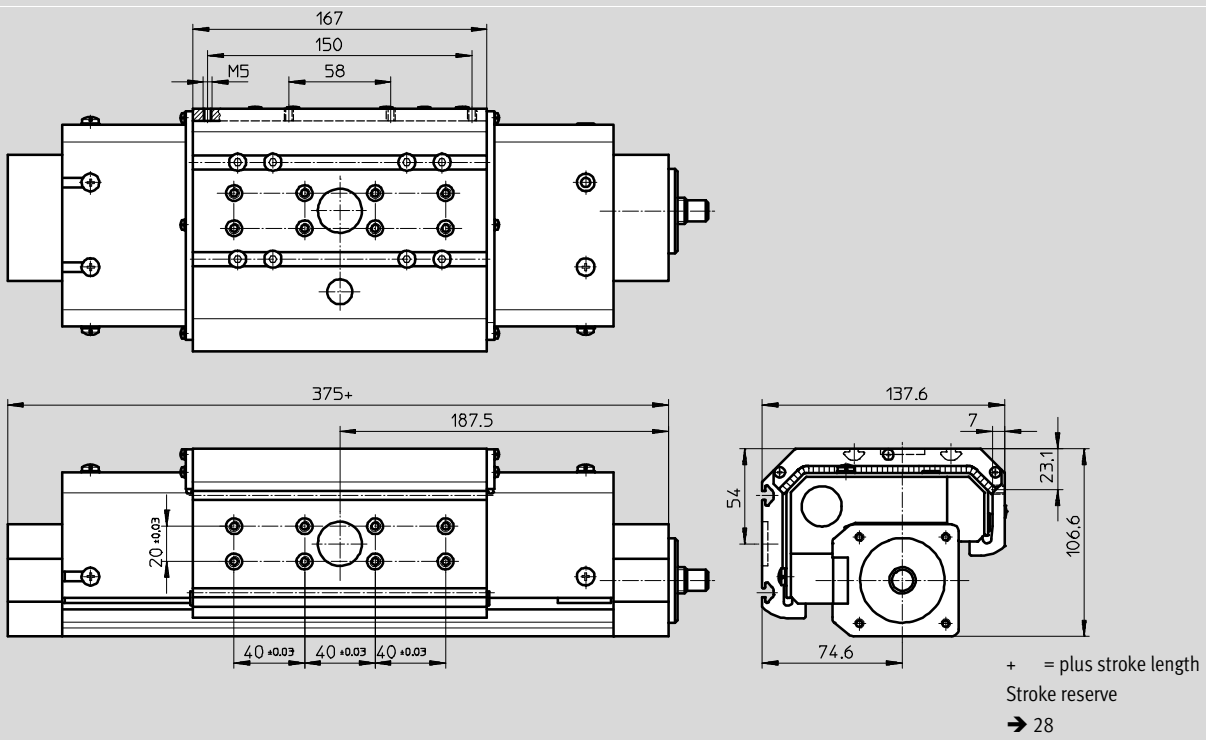

# Spindle axes DGE-SP-KF, with recirculating ball bearing guide

Ordering data – Modular products

**Order code**

**Mandatory data**

Standard slide GK

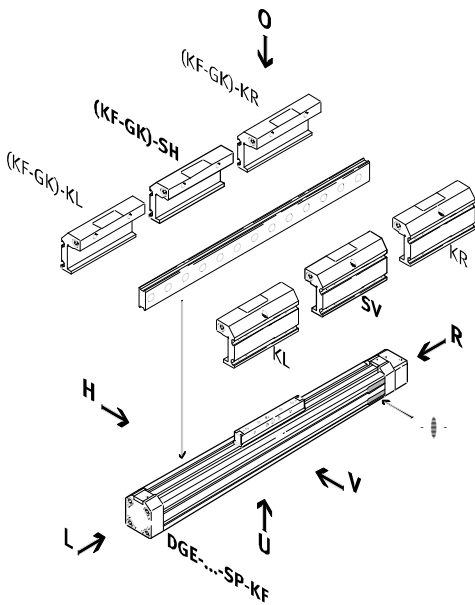

Extended slide GV

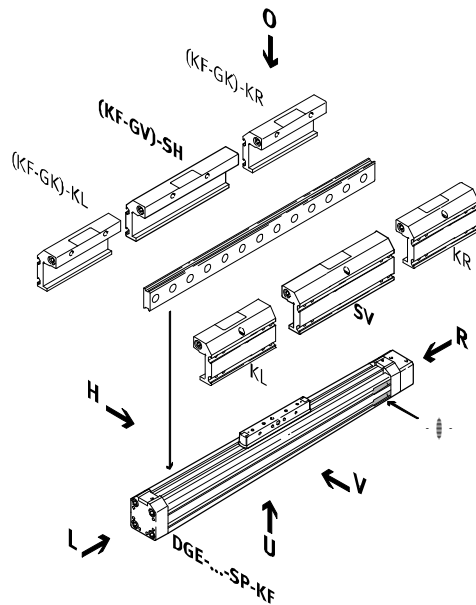

- KF Recirculating ball bearing guide
- KL Additional slide at left
- KR Additional slide at right
- SV Slide at front
- SH Slide at rear

-  - Note

The insertion point for the proximity sensor is located on the right-hand side of the spindle drive  
DGE-...-SP-KF

U = underneath  
O = top  
R = right  
L = left  
V = front  
H = rear

Protected version GA

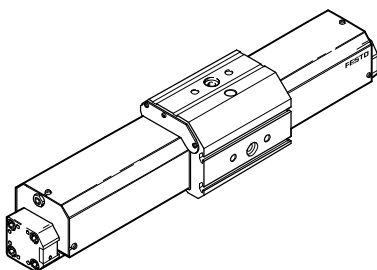

# Spindle axes DGE-SP-KF, with recirculating ball bearing guide

Ordering data – Modular products

**FESTO**

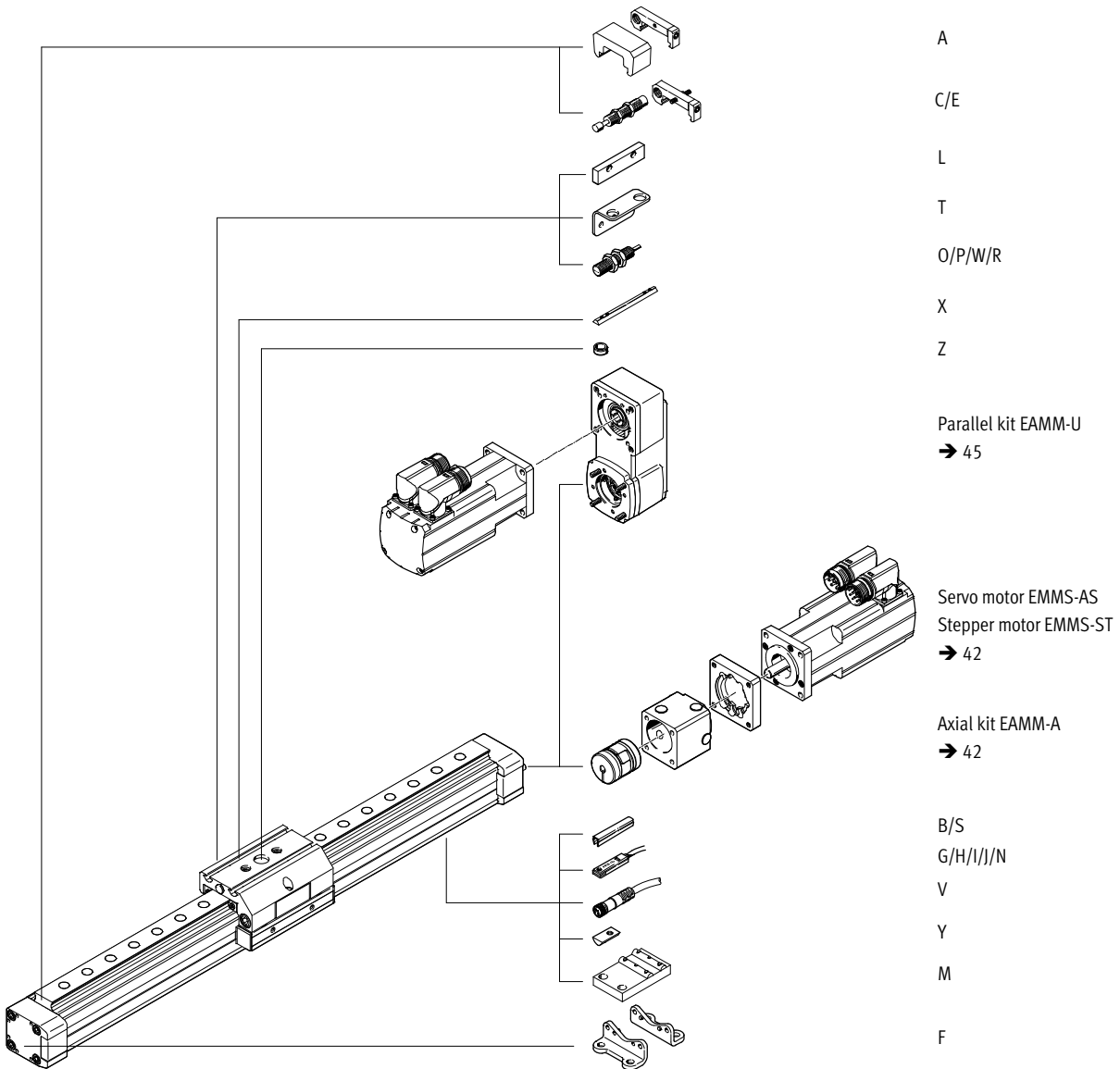

# Spindle axes DGE-SP-KF, with recirculating ball bearing guide

Ordering data – Modular products

**M** Mandatory data →

Module No.	Design	Size	Stroke	Drive function
193745 193746 193747 193748	DGE	18 25 40 63	1 ... 2000	SP
<b>Ordering example</b>				
<b>193745</b>	<b>DGE</b>	<b>- 18</b>	<b>- 410</b>	<b>- SP</b>

Ordering table									
Size	18	25	40	63	Condi- tions	Code	Enter code		
<b>M</b> Module No.	<b>193745</b>	<b>193746</b>	<b>193747</b>	<b>193748</b>					
Design	Electromechanical linear axis					<b>DGE</b>			DGE
Size	18	25	40	63		-...			
Stroke [mm] Standard slide GK	100, 200, 300, 400, 500	100, 200, 300, 400, 500, 600, 700, 800, 900, 1000	200, 300, 400, 500, 600, 800, 1000, 1200, 1400, 1500	300, 400, 500, 600, 800, 1000, 1200, 1400, 1500, 1800, 2000		-...			
	-	1 ... 990	1 ... 1487	1 ... 1982					
Extended slide GV	110, 210, 310, 410	170, 270, 370, 470, 570, 670, 770, 870	170, 270, 370, 570, 770, 970, 1170, 1270	150, 250, 450, 650, 850, 1050, 1150, 1450, 1650		-...			
	-	1 ... 860	1 ... 1257	1 ... 1632					
Protected version GA	-	170, 270, 370, 470, 570, 670, 770, 870, 970	140, 240, 340, 440, 540, 740, 940, 1140, 1340, 1440	-		-...			
	-	1 ... 960	1 ... 1427	-					
Drive function	Electromechanical drive with ball screw					<b>-SP</b>			-SP

Transfer order code

**DGE** -  -  - **SP**

# Spindle axes DGE-SP-KF, with recirculating ball bearing guide

Ordering data – Modular products

0 Options <span style="float: right;">→</span>			
<b>Guide</b>	<b>Slide</b>	<b>Slide attachment position</b>	<b>Additional slide</b>
KF	GK GV GA	SV SH	KL KR
- <b>KF</b>	- <b>GV</b>	- <b>SV</b>	-

Ordering table								
Size	18	25	40	63	Condi- tions	Code	Enter code	
0 Guide	Recirculating ball bearing guide				1	-KF	-KF	
Slide	Standard		Standard		2	-GK		
	Extended		Extended		3	-GV		
	Dust protection	-	Dust-proof version		-	3	-GA	
Slide attachment position	Slide at front					-SV		
	Slide at rear					-SH		
Additional slide	left (effective stroke reduction)	Standard slide at left (85 mm*)		(105 mm*)	(167 mm*)	(230 mm*)	4	-KL
	right (effective stroke reduction)	Standard slide at right (85 mm*)		(105 mm*)	(167 mm*)	(230 mm*)	4	-KR

\* Plus working tolerance between slide and additional slide.

- 1 **KF** Only with slide GK, GV, GA.
- 2 **GK** Only with slide attachment position SV, SH.  
Emergency buffer recommended → Accessory option "A".

3 **GV, GA** Only with slide attachment position SV, SH.  
Emergency buffer included in delivery.

4 **KL, KR** Not with slide GA.  
Emergency buffer recommended → Accessory option "A".

Transfer order code

-  -  -  -



# Spindle axes DGE-SP-KF, with recirculating ball bearing guide

Ordering data – Modular products

0 Options												
Accessories	Slot cover	Slot nut	Central support	Foot mounting	Emergency buffer and retainer	Shock absorber	Centring pins/sleeves	Proximity sensor	Plug socket	Sensor bracket	Switching lug	Inductive sensor
ZUB	...S ...B	...Y ...X	...M	...F	...A	...C ...E	...Z	...G ...H ...I ...J ...N	...V	...T	L	...O ...P ...W ...R
ZUB	- 2S	10Y		F				2G				

Ordering table												
Size			18	25	40	63	Conditions	Code	Enter code			
↓	Accessories	Supplied separately								ZUB-	ZUB-	
0	Slot cover	Sensor slot	1 ... 10						...S			
		Mounting slot	-	-	1 ... 10				...B			
	Slot nut	for mounting slot	1 ... 10						...Y			
		for slide	-	1 ... 10						...X		
	Central support	1 ... 10								...M		
	Foot mounting (kit)	1 ... 10								...F		
	Emergency buffer and retainer for KF	(effective stroke reduction with emergency buffer at both ends)	1 ... 2	(10 mm)	(30 mm)	(60 mm)	(100 mm)	9	...A			
			Shock absorber and retainer for KF-GK, KF-GV	1 ... 2					10	...C		
			for KF-GA	-	1 ... 2					11	...E	
			Centring pins/sleeves (pack of 10)	10, 20, 30, 40, 50, 60, 70, 80, 90								...Z
	Proximity sensor	with cable, 2.5 m	1 ... 10						...G			
		with plug	1 ... 10						...H			
		contactless with cable, 2.5 m	1 ... 10						...I			
		contactless, plug	1 ... 10						...J			
		NC contact with cable, 2.5 m	1 ... 10						...N			
	Cable with socket, 2.5 m	1 ... 10								...V		
	Sensor bracket for inductive sensors	1 ... 5						10	...T			
	Switching lug	1								10	L	
	Inductive sensor	NO contact, cable	1 ... 5						10	...O		
		NC contact, cable	1 ... 5						10	...P		
		NO contact, plug	1 ... 5						10	...W		
		NC contact, plug	1 ... 5						10	...R		

- 9 A Only with slide GK.  
Mounted as standard for slide GV, GA
- 10 C, T, L, O, P, W, R.  
Not with slide GA.

- 11 E Only with slide GA.



Transfer order code

ZUB -

# Spindle axes DGE

Accessories

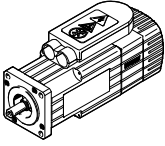
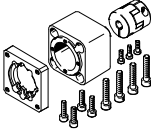
FESTO

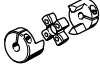
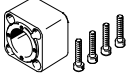
Permissible axis/motor combinations with axial kit – Without gear unit					Technical data → Internet: eamm-a
Motor	Axial kit	Axial kit consisting of:			
		Motor flange	Coupling	Coupling housing	
					
Type	Part No. Type	Part No. Type	Part No. Type	Part No. Type	
<b>DGE-18-...-SP</b>					
With servo motor					
<b>EMMS-AS-40-...</b>	550961 EAMM-A-E20-40A	552163 EAMF-A-28B-40A	540751 EAMC-B-15-22-5-6	170374 EAMK-A-E20-28B	
<b>EMMS-AS-55-...</b>	550963 EAMM-A-E20-55A	529946 EAMF-A-28A/B-55A	529953 EAMC-B-15-22-5-9	170374 EAMK-A-E20-28B	
With stepper motor					
<b>EMMS-ST-42-...</b>	550962 EAMM-A-E20-42A	552164 EAMF-A-28B-42A	530085 EAMC-B-15-22-5-5	170374 EAMK-A-E20-28B	
<b>DGE-25-...-SP</b>					
With servo motor					
<b>EMMS-AS-40-...</b>	550964 EAMM-A-E32-40A	550985 EAMF-A-44A/B-40A	123040 EAMC-30-35-6-6	124631 EAMK-A-E32-44A	
<b>EMMS-AS-55-...</b>	550965 EAMM-A-E32-55A	529942 EAMF-A-44A/B-55A	530941 EAMC-30-35-6-9	124631 EAMK-A-E32-44A	
With stepper motor					
<b>EMMS-ST-57-...</b>	550966 EAMM-A-E32-57A	530081 EAMF-A-44A/B-57A	530087 EAMC-30-35-6-6.35	124631 EAMK-A-E32-44A	
With integrated drive					
<b>EMCA-EC-67-...</b>	1454246 EAMM-A-E32-67A	1476305 EAMF-A-44A/B/C-67A-S1	530941 EAMC-30-35-6-9	124631 EAMK-A-E32-44A	

# Spindle axes DGE

Accessories

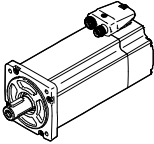
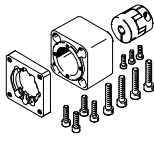
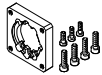
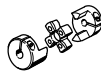
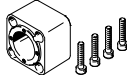

FESTO

Permissible axis/motor combinations with axial kit – Without gear unit					Technical data → Internet: eamm-a
Motor	Axial kit	Axial kit consisting of:			
		Motor flange	Coupling	Coupling housing	
					
Type	Part No. Type	Part No. Type	Part No. Type	Part No. Type	
<b>DGE-40-...-SP</b>					
With servo motor					
EMMS-AS-55-...	550969 EAMM-A-E48-55A	529942 EAMF-A-44A/B-55A	550996 EAMC-30-35-9-12	124632 EAMK-A-E48-44A	
EMMS-AS-70-...	550971 EAMM-A-E48-44A-70A	529943 EAMF-A-44A/B-70A	123051 EAMC-30-35-11-12	124632 EAMK-A-E48-44A	
EMME-AS-100-...	550973 EAMM-A-E48-100A	529947 EAMF-A-64A/C/D-100A	529952 EAMC-40-66-12-19	529940 EAMK-A-E48-64A	
EMMS-AS-100-...	550973 EAMM-A-E48-100A	529947 EAMF-A-64A/C/D-100A	529952 EAMC-40-66-12-19	529940 EAMK-A-E48-64A	
With stepper motor					
EMMS-ST-57-...	550970 EAMM-A-E48-57A	530081 EAMF-A-44A/B-57A	550995 EAMC-30-35-6.35-12	124632 EAMK-A-E48-44A	
EMMS-ST-87-...	550972 EAMM-A-E48-87A	533140 EAMF-A-64A/B-87A	525864 EAMC-40-66-11-12	529940 EAMK-A-E48-64A	
<b>DGE-63-...-SP</b>					
With servo motor					
EMMS-AS-70-...	550975 EAMM-A-E72-70A	529945 EAMF-A-64A/B-70A	550999 EAMC-40-66-11-20	529941 EAMK-A-E72-64A	
EMME-AS-100-...	550978 EAMM-A-E72-100A	529947 EAMF-A-64A/C/D-100A	123847 EAMC-40-66-19-20	529941 EAMK-A-E72-64A	
EMMS-AS-100-...	550978 EAMM-A-E72-100A	529947 EAMF-A-64A/C/D-100A	123847 EAMC-40-66-19-20	529941 EAMK-A-E72-64A	
With stepper motor					
EMMS-ST-87-...	550977 EAMM-A-E72-87A	533140 EAMF-A-64A/B-87A	550999 EAMC-40-66-11-20	529941 EAMK-A-E72-64A	

# Spindle axes DGE

Accessories

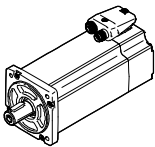
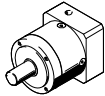
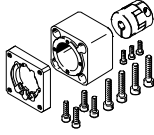

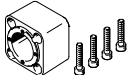

Permissible axis/motor combinations with axial kit – With gear unit						Technical data → Internet: eamm-a
Motor	Gear unit	Axial kit	Axial kit consisting of:			
			Motor flange	Coupling	Coupling housing	
						
Type	Type	Part No. Type	Part No. Type	Part No. Type	Part No. Type	
<b>DGE-25-...-SP</b>						
With servo motor						
<b>EMME-AS-40-...</b>	<b>EMGA-40-P-G...-EAS-40</b>	1454247 EAMM-A-E32-40G	550986 EAMF-A-44A/B-40G	1453062 EAMC-30-35-6-10	124631 EAMK-A-E32-44A	
<b>EMMS-AS-40-...</b>	<b>EMGA-40-P-G...-SAS-40</b>	1454247 EAMM-A-E32-40G	550986 EAMF-A-44A/B-40G	1453062 EAMC-30-35-6-10	124631 EAMK-A-E32-44A	
With stepper motor						
<b>EMMS-ST-42-...</b>	<b>EMGA-40-P-G...-SST-42</b>	1454247 EAMM-A-E32-40G	550986 EAMF-A-44A/B-40G	1453062 EAMC-30-35-6-10	124631 EAMK-A-E32-44A	
With integrated drive						
<b>EMCA-EC-67-...</b>	<b>EMGC-40-...</b>	1454247 EAMM-A-E32-40G	550986 EAMF-A-44A/B-40G	1453062 EAMC-30-35-6-10	124631 EAMK-A-E32-44A	
<b>DGE-40-...-SP</b>						
With servo motor						
<b>EMME-AS-40-...</b>	<b>EMGA-40-P-G...-EAS-40</b>	550968 EAMM-A-E48-40G	550986 EAMF-A-44A/B-40G	552640 EAMC-30-35-10-12	124632 EAMK-A-E48-44A	
<b>EMMS-AS-40-...</b>	<b>EMGA-40-P-G...-SAS-40</b>	550968 EAMM-A-E48-40G	550986 EAMF-A-44A/B-40G	552640 EAMC-30-35-10-12	124632 EAMK-A-E48-44A	
<b>EMME-AS-60-...</b>	<b>EMGA-60-P-G...-EAS-60</b>	1454249 EAMM-A-E48-60H	550987 EAMF-A-64A/B-60G/H	1452803 EAMC-40-66-12-14	529940 EAMK-A-E48-64A	
With stepper motor						
<b>EMMS-ST-42-...</b>	<b>EMGA-40-P-G...-SST-42</b>	550968 EAMM-A-E48-40G	550986 EAMF-A-44A/B-40G	552640 EAMC-30-35-10-12	124632 EAMK-A-E48-44A	
With integrated drive						
<b>EMCA-EC-67-...</b>	<b>EMGC-40-...</b>	550968 EAMM-A-E48-40G	550986 EAMF-A-44A/B-40G	552640 EAMC-30-35-10-12	124632 EAMK-A-E48-44A	
<b>EMCA-EC-67-...</b>	<b>EMGC-60-...</b>	1454249 EAMM-A-E48-60H	550987 EAMF-A-64A/B-60G/H	1452803 EAMC-40-66-12-14	529940 EAMK-A-E48-64A	

# Spindle axes DGE

Accessories

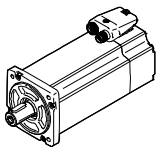
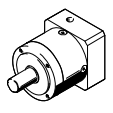
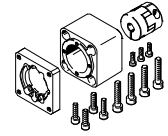

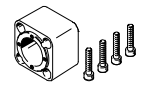
Permissible axis/motor combinations with axial kit – With gear unit					Technical data → Internet: eamm-a
Motor	Gear unit	Axial kit	Axial kit consisting of:		
			Motor flange	Coupling	Coupling housing
					
Type	Type	Part No. Type	Part No. Type	Part No. Type	Part No. Type
<b>DGE-63-...-SP</b>					
With servo motor					
EMMS-AS-55-...	EMGA-60-P-G...-SAS-55	550974 EAMM-A-E72-60G	550987 EAMF-A-64A/B-60G/H	550999 EAMC-40-66-11-20	529941 EAMK-A-E72-64A
EMME-AS-60-...	EMGA-60-P-G...-EAS-60	1454250 EAMM-A-E72-60H	550987 EAMF-A-64A/B-60G/H	1452809 EAMC-40-66-14-20	529941 EAMK-A-E72-64A
EMMS-AS-70-...	EMGA-60-P-G...-SAS-70	550974 EAMM-A-E72-60G	550987 EAMF-A-64A/B-60G/H	550999 EAMC-40-66-11-20	529941 EAMK-A-E72-64A
EMMS-AS-70-...	EMGA-80-P-G...-SAS-70	550976 EAMM-A-E72-80G	533139 EAMF-A-64A/C-80G	123849 EAMC-40-66-20-20	529941 EAMK-A-E72-64A
EMME-AS-80-...	EMGA-80-P-G...-EAS-80	550976 EAMM-A-E72-80G	533139 EAMF-A-64A/C-80G	123849 EAMC-40-66-20-20	529941 EAMK-A-E72-64A
EMMS-AS-100-...	EMGA-80-P-G...-SAS-100	550976 EAMM-A-E72-80G	533139 EAMF-A-64A/C-80G	123849 EAMC-40-66-20-20	529941 EAMK-A-E72-64A
With stepper motor					
EMMS-ST-57-...	EMGA-60-P-G...-SST-57	550974 EAMM-A-E72-60G	550987 EAMF-A-64A/B-60G/H	550999 EAMC-40-66-11-20	529941 EAMK-A-E72-64A
EMMS-ST-87-...	EMGA-80-P-G...-SST-87	550976 EAMM-A-E72-80G	533139 EAMF-A-64A/C-80G	123849 EAMC-40-66-20-20	529941 EAMK-A-E72-64A
With integrated drive					
EMCA-EC-67-...	EMGC-60-...	1454250 EAMM-A-E72-60H	550987 EAMF-A-64A/B-60G/H	1452809 EAMC-40-66-14-20	529941 EAMK-A-E72-64A

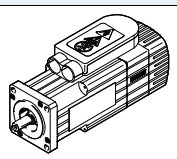
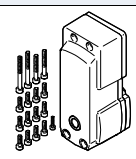
Permissible axis/motor combinations with parallel kit – Without gear unit			Technical data → Internet: eamm-u
Motor	Parallel kit		
			<ul style="list-style-type: none"> <li>• Space-saving gravity die-cast housing</li> <li>• Components can be mounted to the kit facing any direction</li> </ul>
Type	Part No.	Type	
<b>DGE-25-...-SP</b>			
With servo motor			
EMMS-AS-55-...	543230	EAMM-U-E32-55A	
With motor unit			
MTR-DCI-42S-...-G07	543228	EAMM-U-E32-42B	
MTR-DCI-42S-...-G14	543229	EAMM-U-E32-42C	
<b>DGE-40-...-SP</b>			
With servo motor			
EMMS-AS-70-...	543234	EAMM-U-E48-70A	
With motor unit			
MTR-DCI-52S-...-G07	543232	EAMM-U-E48-52B	
MTR-DCI-52S-...-G14	543233	EAMM-U-E48-52C	

# Spindle axes DGE

Accessories



## Foot mounting HP (order code F)

Material:  
Galvanised steel  
Free of copper and PTFE



HP-25

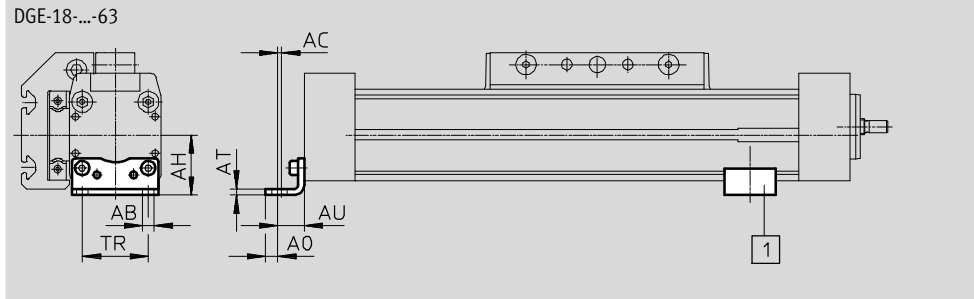

Dimensions and ordering data											
For size	AB ∅	AC	AH	AO	AT	AU	TR	Weight [g]	Part No.	Type	
18	5.5	2	24	4.8	3	13.3	24	70	158472	HP-18	
25	5.5	2	29.5	6	3	13	32.5	61	150731	HP-25	
40	6.6	2	46	8.5	5	17.5	45	188	150733	HP-40	
63	11	3	69	13.5	6	28	75	305	150735	HP-63	

## Central support MUP (order code M)

Material:  
Anodised aluminium  
Free of copper and PTFE



MUP-40

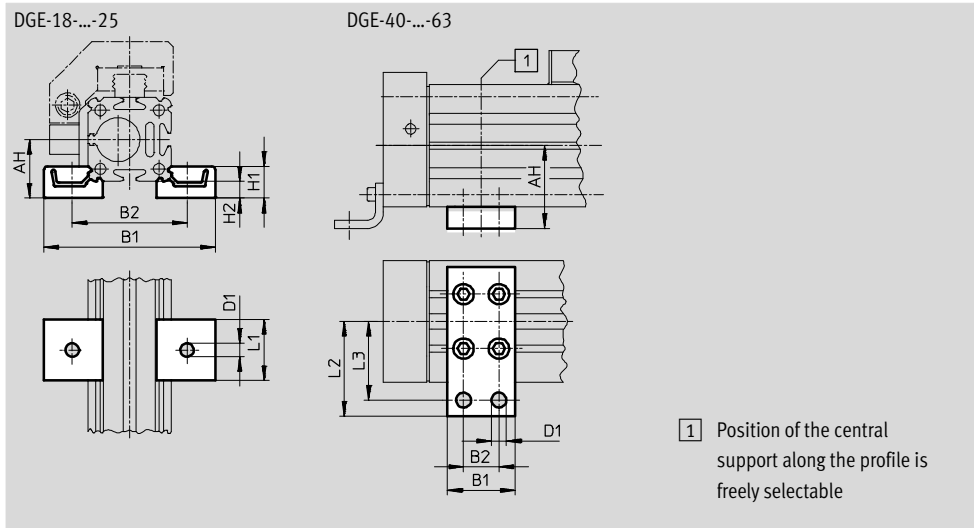

1 Position of the central support along the profile is freely selectable

Dimensions and ordering data												
For size	AH	B1	B2	D1 ∅	H1	H2	L1	L2	L3	Weight [g]	Part No.	Type
18	24	70.5	47	5.5	13	7	25	-	-	33	150736	MUP-18/25
25	29.5	81	58	5.5	13	7	25	-	-	33	150736	MUP-18/25
40	46	35	22	6.6	-	-	-	47	40	126	150738	MUP-40
63	69	50	26	11	-	-	-	77	65	340	150800	MUP-63

# Spindle axes DGE

Accessories

## Shock absorber YSR-...-C (order code C)

Materials:  
Housing: Galvanised steel; piston rod:  
high-alloy steel  
Seals: nitrile rubber, polyurethane  
Free of copper and PTFE



 Note  
Shock absorber YSRW with  
progressive characteristics  
→ Internet: ysrw

Ordering data		Part No.	Type
For size	Weight [g]		
18	30	34571	YSR-8-8-C
25	70	34572	YSR-12-12-C
40	140	34573	YSR-16-20-C
63	240	34574	YSR-20-25-C

## Shock absorber retainer KYP (order code C)

Materials:  
Retainer: Aluminium  
Sleeve: Corrosion-resistant steel

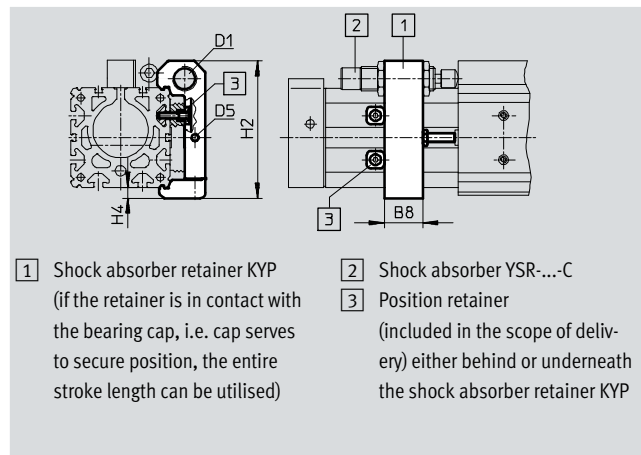

Dimensions and ordering data								
For size	B8	D1	D5	H2	H4	Weight [g]	Part No.	Type
18	14	M12x1	M4	50.5	4.5	66	158907	KYP-18
25	19	M16x1	M5	69.5	6	95	158908	KYP-25
40	32	M22x1.5	M5	102	8	209	158910	KYP-40
63	44	M26x1.5	M10	152.5	11.5	609	158912	KYP-63

# Spindle axes DGE

Accessories

FESTO

## Emergency buffer NPE (order code A)

Material:  
Polyurethane

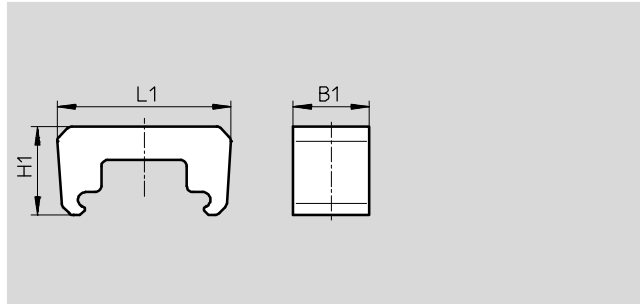
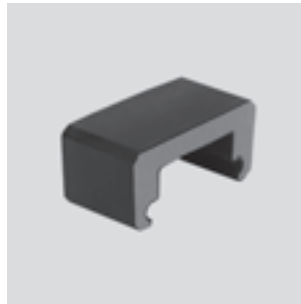

Dimensions and ordering data						
For size	B1	L1	H1	Weight [g]	Part No.	Type
18	15	43.1	28.5	6	193901	NPE-18
25	25	57	29	12	193902	NPE-25
40	40	80.5	36	41	193904	NPE-40
63	60	128.6	55	152	193906	NPE-63

 Note  
The emergency buffer can only be used in combination with shock absorber retainer KYP. → 47  
(A threaded stud and nut are not required.)

## Shock absorber DG-GA for protected version GA (order code E)

Materials:  
Housing: Galvanised steel; piston rod: high-alloy steel  
Seals: nitrile rubber, polyurethane  
Free of copper and PTFE



Ordering data			
For size	Weight [g]	Part No.	Type
25	70	192875	DG-GA-25-YSR
40	140	192877	DG-GA-40-YSR



# Spindle axes DGE

Accessories

## Sensor bracket HWS

for inductive proximity sensors

(order code T)

Material:

Galvanised steel





## Switch lug SF

(order code L)

Material:

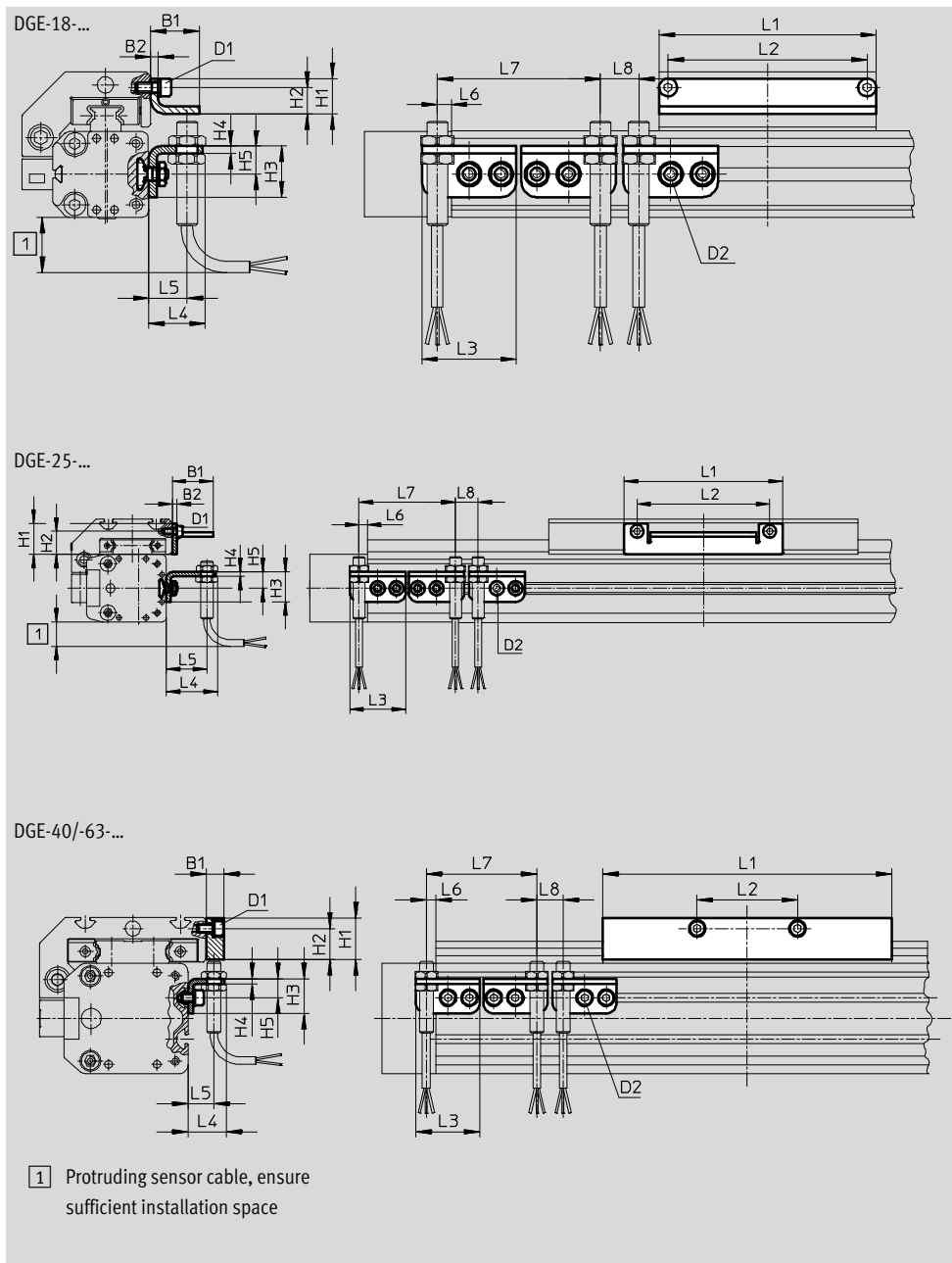
Galvanised steel



-  - Note  
 Cannot be used in combination with the variant DGE-...-GA (protected version).

# Spindle axes DGE

Accessories





Dimensions and ordering data														
For size	D1	D2	B1	B2	H1	H2	H3	H4	H5	L1	L2	L3	L4	L5
18	M4	M5	19	3	14	10.5	20	3	11	85	78	37	22.5	15
25	M5	M5	27	3	20.5	15.3	20	3	11	105	88	37	34.5	27
40	M5	M5	10	–	24	18	20	3	11	167	58	37	22.5	15
63	M8	M5	10	–	35	25	20	3	11	230	72	37	22.5	15

For size	L6 max.	L7 min.	L8 min.	Weight [g]	Part No.	Type
18	5.5	64	15	30	<b>188968</b>	<b>HWS-18/25-M8</b>
				60	<b>188964</b>	<b>SF-18</b>
25	5.5	64	15	30	<b>540780</b>	<b>HWS-25-MAB-M8</b>
				80	<b>540430</b>	<b>SF-25-MAB</b>
40	5.5	64	15	40	<b>188969</b>	<b>HWS-40-M8</b>
				310	<b>188966</b>	<b>SF-40</b>
63	5.5	64	15	40	<b>188970</b>	<b>HWS-63-M8</b>
				630	<b>188967</b>	<b>SF-63</b>

# Spindle axes DGE

Accessories

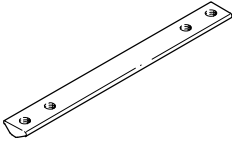
FESTO

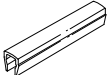
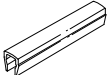

Ordering data				Technical data → Internet: mounting attachment		
	For size	Comment	Order code	Part No.	Type	PU <sup>1)</sup>
<b>Slot nut NST</b>						
	18, 25	For mounting slot	Y	<b>526091</b>	<b>NST-HMV-M4</b>	10
	40			<b>150914</b>	<b>NST-5-M5</b>	1
	63			<b>150915</b>	<b>NST-8-M6</b>	1
<b>Slot nut NSTL</b>						
	25	For slide	X	<b>158410</b>	<b>NSTL-25</b>	1
	40			<b>158412</b>	<b>NSTL-40</b>	1
	63			<b>158414</b>	<b>NSTL-63</b>	1
<b>Centring pin/sleeve ZBS/ZBH</b>						
	18	For slide	Z	<b>150928</b>	<b>ZBS-5</b>	10
	25 ... 63			<b>150927</b>	<b>ZBH-9</b>	10
<b>Slot cover ABP</b>						
	40	For mounting slot every 0.5 m	B	<b>151681</b>	<b>ABP-5</b>	2
	63			<b>151682</b>	<b>ABP-8</b>	
<b>Slot cover ABP-S</b>						
	18 ... 63	For sensor slot every 0.5 m	S	<b>151680</b>	<b>ABP-5-S</b>	2



1) Packaging unit



# Spindle axes DGE



Accessories

FESTO

Ordering data – Proximity sensors for T-slot, magnetic reed						Technical data → Internet: sme	
	Type of mounting	Switching output	Electrical connection	Cable length [m]	Part No.	Type	
N/O contact							
	Insertable in the slot lengthwise, flush with the cylinder profile	Contacting	Cable, 3-wire	2.5	<b>150855</b>	<b>SME-8-K-LED-24</b>	
			Plug M8x1, 3-pin	0.3	<b>150857</b>	<b>SME-8-S-LED-24</b>	
N/C contact							
	Insertable in the slot lengthwise, flush with the cylinder profile	Contacting	Cable, 3-wire	7.5	<b>160251</b>	<b>SME-8-O-K-LED-24</b>	

Ordering data – Proximity sensors for T-slot, magneto-resistive						Technical data → Internet: smt	
	Type of mounting	Switch output	Electrical connection	Cable length [m]	Part No.	Type	
N/O contact							
	Insertable in the slot from above, flush with cylinder profile, short design	PNP	Cable, 3-wire	2.5	<b>574335</b>	<b>SMT-8M-A-PS-24V-E-2,5-OE</b>	
			Plug M8x1, 3-pin	0.3	<b>574334</b>	<b>SMT-8M-A-PS-24V-E-0,3-M8D</b>	
N/C contact							
	Insertable in the slot from above, flush with cylinder profile, short design	PNP	Cable, 3-wire	7.5	<b>574340</b>	<b>SMT-8M-A-PO-24V-E-7,5-OE</b>	

Ordering data – Inductive proximity sensors M8						Technical data → Internet: sien	
	Electrical connection		Switching output	LED	Cable length [m]	Part No.	Type
	Cable	Plug M8					
N/O contact							
	3-wire	–	PNP	■	2.5	<b>150386</b>	<b>SIEN-M8B-PS-K-L</b>
	–	3-pin	PNP	■	–	<b>150387</b>	<b>SIEN-M8B-PS-S-L</b>
N/C contact							
	3-wire	–	PNP	■	2.5	<b>150390</b>	<b>SIEN-M8B-PO-K-L</b>
	–	3-pin	PNP	■	–	<b>150391</b>	<b>SIEN-M8B-PO-S-L</b>

Ordering data – Connecting cables					Technical data → Internet: nebu	
	Electrical connection, left	Electrical connection, right	Cable length [m]	Part No.	Type	
	Straight socket, M8x1, 3-pin	Cable, open end, 3-wire	2.5	<b>541333</b>	<b>NEBU-M8G3-K-2.5-LE3</b>	
			5	<b>541334</b>	<b>NEBU-M8G3-K-5-LE3</b>	
	Angled socket, M8x1, 3-pin	Cable, open end, 3-wire	2.5	<b>541338</b>	<b>NEBU-M8W3-K-2.5-LE3</b>	
			5	<b>541341</b>	<b>NEBU-M8W3-K-5-LE3</b>	

# Spindle axes DGE

Accessories

**Adapter kit  
HMVK**

Material:  
Wrought aluminium alloy  
Free of copper and PTFE  
RoHS-compliant

 Note  
The kit includes the individual mounting interface as well as the necessary mounting material.

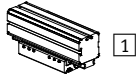
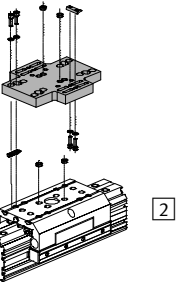
Permissible drive/drive combinations with adapter kit			Download CAD data → <a href="http://www.festo.com">www.festo.com</a>		
Combination	[1] Drive	[2] Drive	Adapter kit		
	Size	Size	CRC <sup>1)</sup>	Part No.	Type
DGE, DGEA/DGE	DG...	DGE	HMVK		
 	Direct slide/slide mounting				
	18, 25	25	2	196779	HMVK-DL25-DL18/25
	25	32		196781	HMVK-DL32/40-DLA18-32
	18 <sup>2)</sup> , 25, 32 <sup>3)</sup>	40		196781	HMVK-DL32/40-DLA18-32
	25 <sup>2)</sup> , 40	63		196783	HMVK-DL63-DLA25/40
	Direct slide/profile mounting				
	18	18	2	196780	HMVK-DL18/25-DL18/25
	25	25		196780	HMVK-DL18/25-DL18/25
	25	32, 40		196782	HMVK-DL32/40-DL25
	32 <sup>3)</sup> , 40	40		196781	HMVK-DL32/40-DLA18-32

- 1) Corrosion resistance class CRC 2 to Festo standard FN 940070  
Moderate corrosion stress. Indoor applications in which condensation may occur. External visible parts with primarily decorative requirements for the surface and which are in direct contact with the ambient atmosphere typical for industrial applications.
- 2) Only for DGEA-...
- 3) Only for DGPL

## Product Range and Company Overview

### A Complete Suite and Company Overview

Our experienced engineers provide complete support at every stage of your development process, including: conceptualization, analysis, engineering, design, assembly, documentation, validation, and production.



**Custom Automation Components**  
Complete custom engineered solutions



**Custom Control Cabinets**  
Comprehensive engineering support and on-site services



**Complete Systems**  
Shipment, stocking and storage services

### The Broadest Range of Automation Components

With a comprehensive line of more than 30,000 automation components, Festo is capable of solving the most complex automation requirements.



**Electromechanical**  
Electromechanical actuators, motors, controllers & drivers



**Pneumatics**  
Pneumatic linear and rotary actuators, valves, and air supply



**PLCs and I/O Devices**  
PLC's, operator interfaces, sensors and I/O devices

### Supporting Advanced Automation... As No One Else Can!

Festo is a leading global manufacturer of pneumatic and electromechanical systems, components and controls for industrial automation, with more than 16,000 employees in 60 national headquarters serving more than 180 countries. For more than 80 years, Festo has continuously elevated the state of manufacturing with innovations and optimized motion control solutions that deliver higher performing, more profitable automated manufacturing and processing equipment. Our dedication to the advancement of automation extends beyond technology to the education and development of current and future automation and robotics designers with simulation tools, teaching programs, and on-site services.

### Quality Assurance, ISO 9001 and ISO 14001 Certifications

Festo Corporation is committed to supply all Festo products and services that will meet or exceed our customers' requirements in product quality, delivery, customer service and satisfaction.

To meet this commitment, we strive to ensure a consistent, integrated, and systematic approach to management that will meet or exceed the requirements of the ISO 9001 standard for Quality Management and the ISO 14001 standard for Environmental Management.



© Copyright 2013, Festo Corporation. While every effort is made to ensure that all dimensions and specifications are correct, Festo cannot guarantee that publications are completely free of any error, in particular typing or printing errors. Accordingly, Festo cannot be held responsible for the same. For Liability and Warranty conditions, refer to our "Terms and Conditions of Sale", available from your local Festo office. All rights reserved. No part of this publication may be reproduced, distributed, or transmitted in any form or by any means, electronic, mechanical, photocopying or otherwise, without the prior written permission of Festo. All technical data subject to change according to technical update.



Printed on recycled paper at New Horizon Graphic, Inc., FSC certified as an environmental friendly printing plant.

# Festo North America

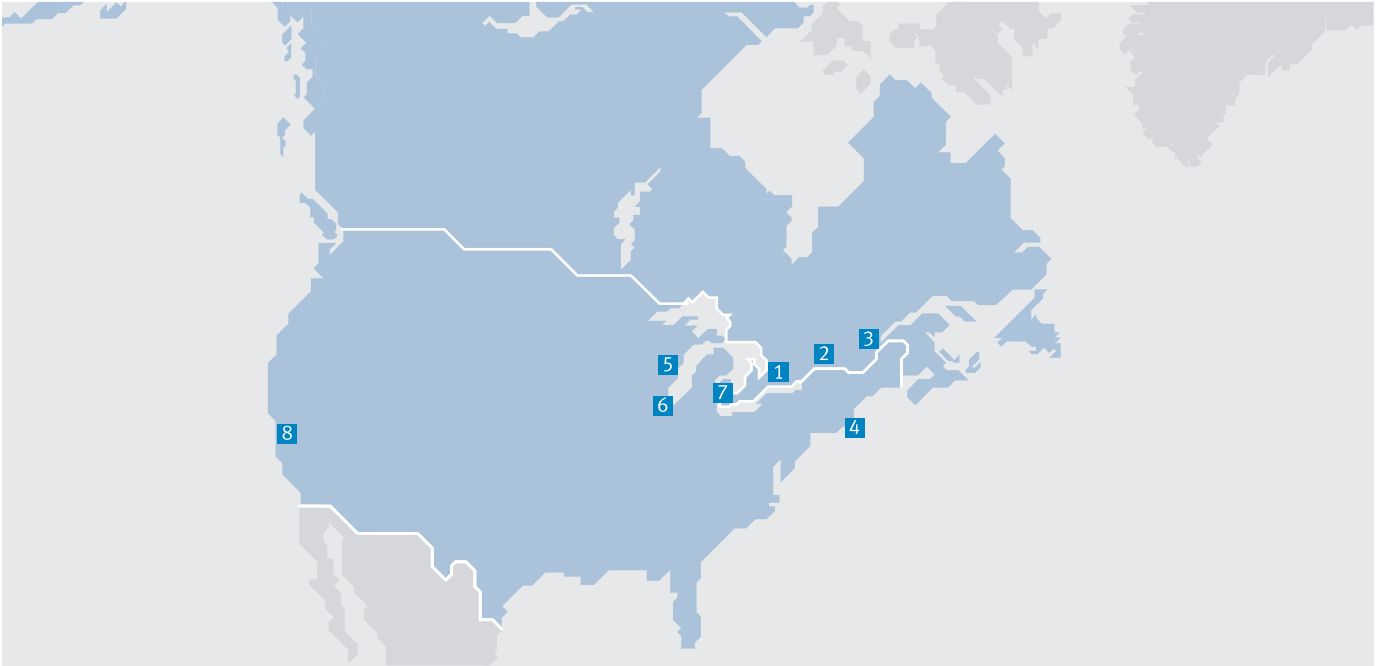

**1 Festo Canada  
Headquarters  
Festo Inc.**  
5300 Explorer Drive  
Mississauga, ON  
L4W 5G4

**2 Montréal**  
5600, Trans-Canada  
Pointe-Claire, QC  
H9R 1B6

**3 Québec City**  
2930, rue Watt#117  
Québec, QC  
G1X 4G3



**4 Festo United States  
Headquarters  
Festo Corporation**  
395 Moreland Road  
Hauppauge, NY  
11788

**5 Appleton**  
North 922 Tower View Drive, Suite N  
Greenville, WI  
54942

**7 Detroit**  
1441 West Long Lake Road  
Troy, MI  
48098

**6 Chicago**  
85 W Algonquin - Suite 340  
Arlington Heights, IL  
60005

**8 Silicon Valley**  
4935 Southfront Road, Suite F  
Livermore, CA  
94550

## Festo Regional Contact Center

### Canadian Customers

Commercial Support:  
Tel: 1 877 GO FESTO (1 877 463 3786)  
Fax: 1 877 FX FESTO (1 877 393 3786)  
Email: festo.canada@ca.festo.com

### Technical Support:

Tel: 1 866 GO FESTO (1 866 463 3786)  
Fax: 1 877 FX FESTO (1 877 393 3786)  
Email: technical.support@ca.festo.com

### USA Customers

Commercial Support:  
Tel: 1 800 99 FESTO (1 800 993 3786)  
Fax: 1 800 96 FESTO (1 800 963 3786)  
Email: customer.service@us.festo.com

### Technical Support:

Tel: 1 866 GO FESTO (1 866 463 3786)  
Fax: 1 800 96 FESTO (1 800 963 3786)  
Email: product.support@us.festo.com