

Stopper cylinders DFSP



Stopper cylinders DFSP

Key features

At a glance

- Versions:
 - Trunnion
 - Trunnion with female thread
 - Roller
- Single-acting, pulling
- Double-acting with spring, pulling
- Double-acting without spring
- With or without protection against rotation
- Compact design
- Sensor slots on 3 sides
- Long service life owing to very good cushioning characteristics and sturdy piston rod guide
- Fast and simple set-up of conveyors
- Workpiece carriers, pallets and packages weighing up to 90 kg can be safely stopped
- Space-saving sensing via integrated proximity sensors

Trunnion version with/without protection against rotation

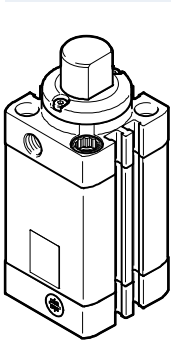

Trunnion version with female thread and with/without protection against rotation

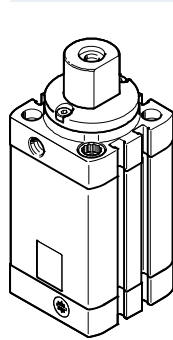

Roller version with protection against rotation

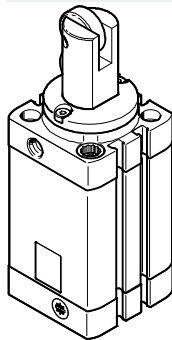

Protection against rotation

The anti-rotation ring can be rotated by 90° by loosening the screws. The compressed air can thus be connected from all 4 sides, independent of the direction of impact.

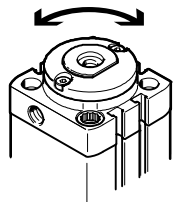

Single-acting cylinders with spring DFSP-...-P

In the DFSP-...-P variant, the cylinder can be operated as a double-acting cylinder by removing the filter nipple in the end cap.

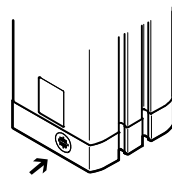

Mounting options

1 Direct mounting on the bearing cap

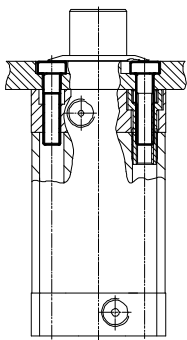

2 Direct mounting via flange mounting DAMF-F7 on the bearing cap

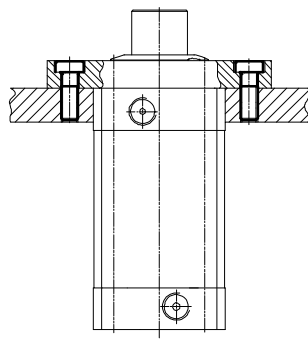

3 Through-hole mounting

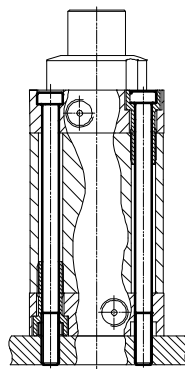

4 Direct mounting on the end cap

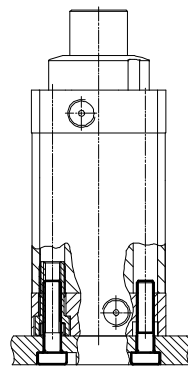

-  - Note

All technical data refer to mounting options 1 and 2. The values can be

significantly lower for the other mounting options.

Adhere to minimum screw-in depths
→ 12

Stopper cylinders DFSP

Key features

Functional sequence

Trunnion version

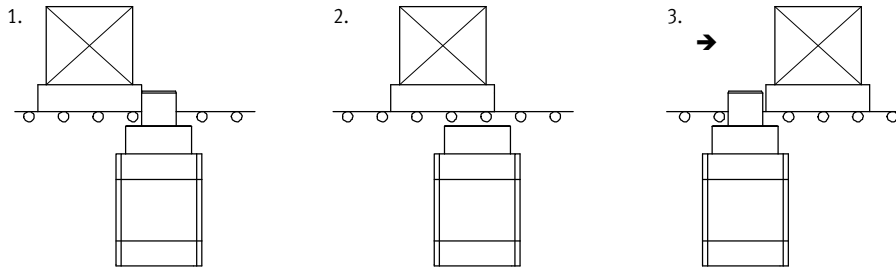

1. Sudden braking of the workpiece carrier via the piston rod.
2. The workpiece carrier is released by actuating the cylinder. The control system must hold the piston down until the workpiece carrier has passed the stopper cylinder.
3. The piston rod then advances by means of spring force or compressed air. The next workpiece carrier can then be stopped.

Roller version

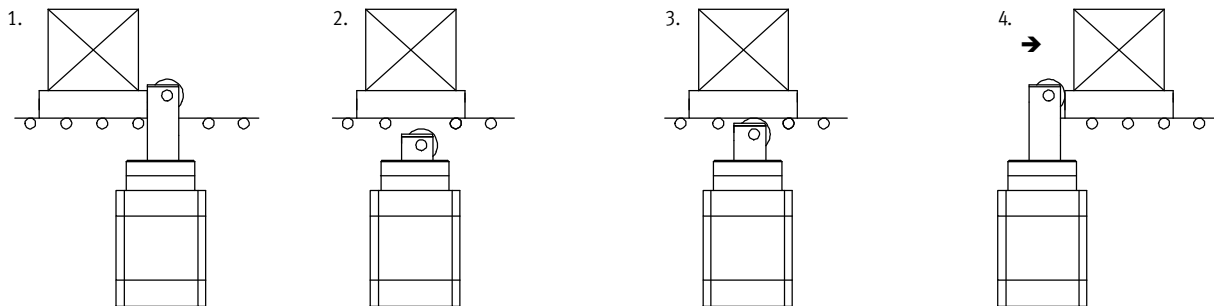

1. Sudden braking of the workpiece carrier via the piston rod.
2. The workpiece carrier is released by actuating the cylinder.
3. The piston rod then advances by means of spring force until the roller makes contact with the workpiece carrier. The workpiece carrier continues to move forward.
4. After the workpiece carrier has passed, the piston rod advances to its end position. The next workpiece carrier can then be stopped.

Application options and versions

Stopping large loads

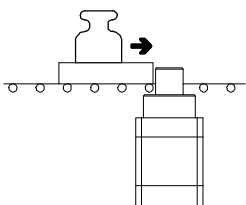

Security

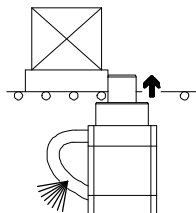

Safe stopping in the event of emergency off or pressure failure is guaranteed as a result of advancing the piston rod using spring force (single-acting/double-acting with spring).

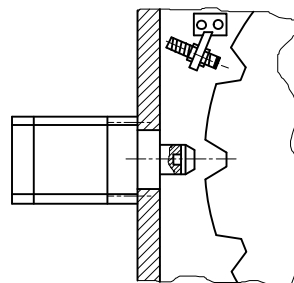



High lateral forces on the piston rod are possible, e.g. as a result of latching or holding loads.

Stopper cylinders DFSP

Product range overview

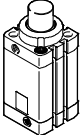
FESTO

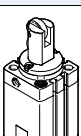
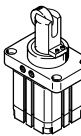
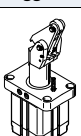
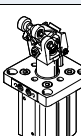
Function	Version	Type	Piston Ø [mm]	Stroke [mm]	Permissible impact force ¹⁾	Type of mounting		→ Page/ Internet
						Direct	Via flange	
Stopper cylinders DFSP								
Single-acting, pulling or double-acting	Trunnion							
		DFSP-...-S DFSP-...-F	16	5 ... 15	880	■	■	5
			20	5 ... 20	1,370	■	■	
			32	5 ... 25	3,270	■	■	
			40	5 ... 30	5,540	■	■	
			50	5 ... 30	6,280	■	■	
	Trunnion with protection against rotation							
		DFSP-Q-...-S DFSP-Q-...-F	16	5 ... 15	880	■	■	5
			20	5 ... 20	1,100	■	■	
			32	5 ... 25	3,270	■	■	
			40	5 ... 30	5,540	■	■	
			50	5 ... 30	6,280	■	■	
	Roller with protection against rotation							
		DFSP-Q-...-R	16	5 ... 15	710	■	■	5
			20	5 ... 20	840	■	■	
32			5 ... 25	2,670	■	■		
40			5 ... 30	4,500	■	■		
50			5 ... 30	5,000	■	■		
Stopper cylinders STAF								
Single-acting, pulling or double-acting	Roller							
		STAF-...-P-A-R	80	30, 40	14,600	-	■	sta
Single-acting, pulling or double-acting	Toggle lever							
		STAF-...-P-A-K	32	20	480	-	■	sta
Stopper cylinders DFST								
Single-acting, pulling or double-acting	Toggle lever							
		DFST-...-	50	30	3,000	-	■	dfst
			63	30	5,000			
			80	40	6,000			

1) On the advanced piston rod

Stopper cylinders DFSP

Type codes and peripherals overview

Type codes

		DFSP	-		-	20	-	15	-		S	-	P	A
Type														
Single-acting or double-acting														
DFSP	Stopper cylinder													
Protection against rotation														
Q	With protection against rotation													
Piston Ø [mm]														
Stroke [mm]														
Function														
-	Double-acting with spring, pulling													
D	Double-acting without spring													
P	Single-acting, pulling													
Piston rod version														
S	Standard (trunnion)													
F	Trunnion with female thread													
R	With roller													
Cushioning														
P	Elastic cushioning rings/plates at both ends													
Position sensing														
A	Via proximity sensor													

Peripherals overview

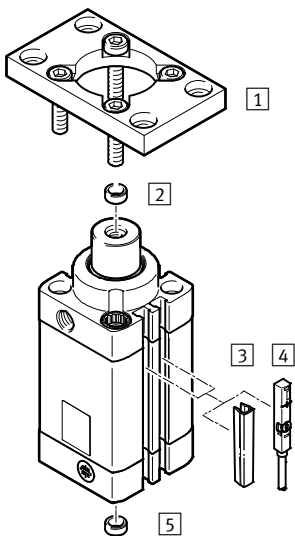

Accessories		
	Brief description	→ Page/ Internet
1	Flange mounting DAMF-F7	20
2	Centring sleeve ZBH	21
3	Slot cover ABP	21
4	Proximity sensor SME/SMT-8	21
5	Centring sleeve ZBH	21

Stopper cylinders DFSP

Technical data

FESTO

Feature

Trunnion

Roller

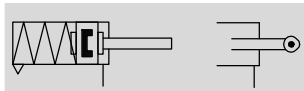
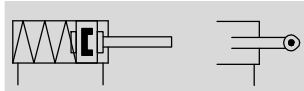
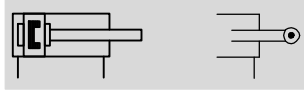

⊘ - Diameter
16 ... 50 mm

— - Stroke length
5 ... 30 mm



General technical data					
Piston ∅	16	20	32	40	50
Pneumatic connection	M5	M5	G $\frac{1}{8}$	G $\frac{1}{8}$	G $\frac{1}{8}$
Stroke [mm]	5 ... 15	5 ... 20	5 ... 25	5 ... 30	5 ... 30
Max. cycle rate [Hz]	5				
Design	Piston Piston rod Piston rod with roller Profile barrel Non-rotating				
Mode of operation	Double-acting with spring, pulling Double-acting without spring Single-acting, pulling				
Cushioning	Elastic cushioning rings/plates at both ends				
Type of mounting	With through-hole With female thread Via accessories				
Position sensing	Via proximity sensor				
Mounting position	Any				

Operating and environmental conditions					
Piston ∅	16	20	32	40	50
Operating medium	Compressed air to ISO 8573-1:2010 [7:4:4]				
Note on operating/pilot medium	Operation with lubricated medium possible (in which case lubricated operation will always be required)				
Min. operating pressure					
Without spring [bar]	1				
With spring [bar]	2.8	1.6	1.2	1.2	1.2
With max. lateral force [bar]	→ Page 10				
Max. operating pressure [bar]	10				
Ambient temperature ¹⁾ [°C]	-10 ... +80				
Corrosion resistance class CRC ²⁾	2				

1) Note operating range of proximity sensors.

2) Corrosion resistance class 2 according to Festo standard 940 070

Components subject to moderate corrosion stress. Externally visible parts with primarily decorative surface requirements which are in direct contact with a normal industrial environment or media such as coolants or lubricating agents.

⊘ - Note

All technical data refer to the mounting options (→ right). The values can be significantly lower for the other mounting options. Adhere to minimum screw-in depths → 12

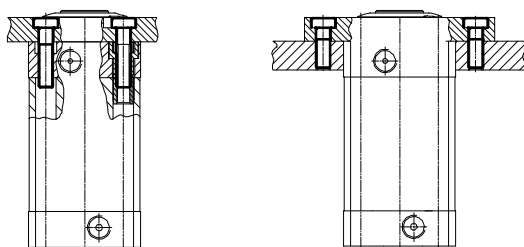

Stopper cylinders DFSP

Technical data

Effective force and impact energy						
Piston Ø		16	20	32	40	50
Effective force at 6 bar, advancing						
DFSP-...	[N]	107	171	438	683	1,064
DFSP-...-D	[N]	121	188	483	754	1,178
Effective force at 6 bar, retracting						
DFSP-...	[N]	74	121	294	459	696
Max. impact energy of the cylinder in the end positions						
DFSP-...	[J]	0.1	0.15	0.4	0.7	1.0

Materials

Sectional view

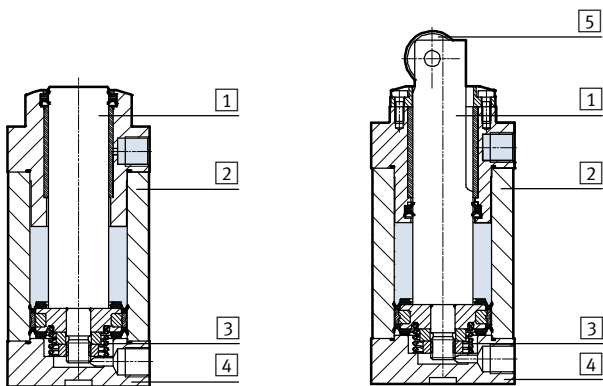

Stopper cylinder		
1	Piston rod	High-alloy stainless steel
2	Profile barrel	Wrought aluminium alloy, hard-anodised
3	Spring	Spring steel
4	Cap	Anodised wrought aluminium alloy
5	Roller	Galvanised steel
-	Flange screws	High-alloy stainless steel
-	Seals	TPE-U(PU)
-	Anti-rotation ring	POM
-	Note on materials	RoHS-compliant

Stopper cylinders DFSP

Technical data

FESTO

Weight [g]					
Piston Ø	16	20	32	40	50
Product weight					
With 0 mm stroke					
DFSP-...-S	113	189	409	633	948
DFSP-...-F	112	188	406	626	941
DFSP-Q-...-S	111	185	402	628	937
DFSP-Q-...-F	110	184	399	621	930
DFSP-Q-...-R	113	188	419	666	1 007
Additional weight per 10 mm stroke					
DFSP-...-S	16.1	24.7	45.5	68.4	99.5
DFSP-...-F					
DFSP-Q-...-S					
DFSP-Q-...-F	15.6	23.7	43.7	65.8	94.9
DFSP-Q-...-R					
Moving mass					
With 0 mm stroke					
DFSP-...-S	30	50	156	263	436
DFSP-...-F	29	50	153	257	429
DFSP-Q-...-S	29	49	155	261	430
DFSP-Q-...-F	29	49	152	254	424
DFSP-Q-...-R	31	52	171	299	501
Additional weight per 10 mm stroke					
DFSP-...-S	6.3	9.0	25.1	39.3	64.3
DFSP-...-F					
DFSP-Q-...-S					
DFSP-Q-...-F	5.7	8.1	23.3	36.6	59.7
DFSP-Q-...-R					
Spring					
	1.3	1.4	3.5	6.4	10.6

Stopper cylinder with protection against rotation

For the DFSP-Q-... (with anti-rotation ring), the alignment and direction of movement of the workpiece carrier must be exactly vertical with respect to the flat impact surface of the piston

rod. Conveyed goods approaching at an angle reduce the service life of the cylinder and can lead to breakage of the anti-rotation ring.

The anti-rotation ring can be rotated by 90° into the desired position.

The compressed air can thus be connected from all 4 sides, independent of the direction of impact.

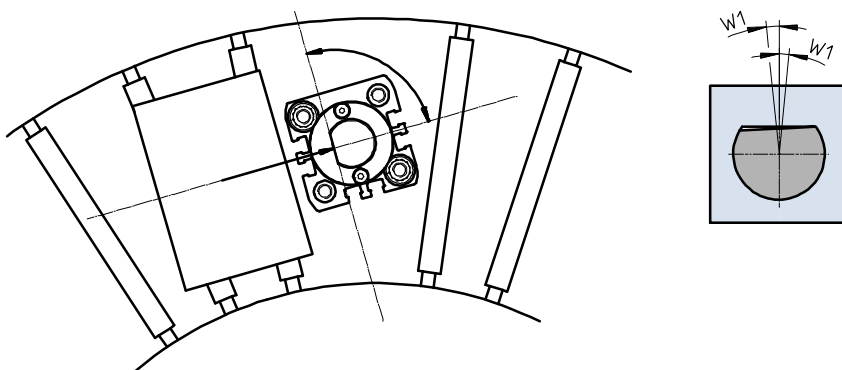

Piston Ø	16	20	32	40	50
Permissible torque on the piston rod [Nm]	1	1.5	2.5	2.5	3.5
Permissible torsional backlash W1 in new condition [°]	±5	±4	±4	±4	±3

Stopper cylinders DFSP

Technical data

Permissible impact force on the advanced piston rod

"Impact force" refers to the maximum of a force-time progression (not known in detail) during the impact or cushioning phase of the moving mass. This acts perpendicularly to the axis of motion of the piston rod. If the flexible

components are considered as linear springs, a permissible impact energy can be calculated from the permissible impact force, which helps in the selection of the correct stopper. The stopper must not operate under this

force.

Depending upon the type of load to be stopped, it is advisable to provide a flexible buffer to cushion the impact, reduce noise levels and to optimise the impact energy.

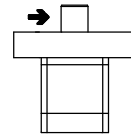

→ = Direction of impact force

Piston Ø		16	20	32	40	50
DFSP-...	[N]	880	1,370	3,270	5,540	6,280
DFSP-Q-...	[N]	880	1 100	3,270	5,540	6,280
DFSP-Q-...-R	[N]	710	840	2,670	4,500	5,000

Permissible load m as a function of conveyor speed v

A prerequisite for the values in the graphs is an elastic buffer on the workpiece carrier with a deformation path of 1 mm.

For a smaller deformation path, the impact force is reduced.

-  Note
Selection aid → 22

DFSP-... / DFSP-Q-... – with trunnion

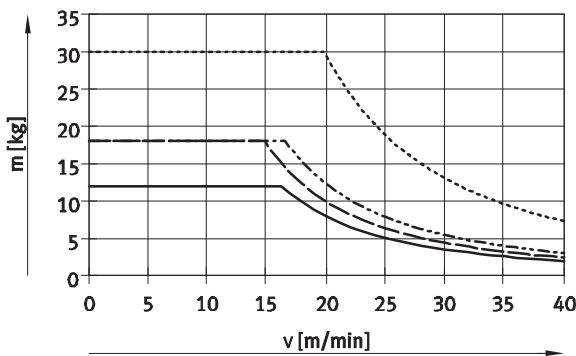

- DFSP-16/DFSP-Q-16
- - - DFSP-20
- · - DFSP-Q-20
- · · DFSP-32/DFSP-Q-32

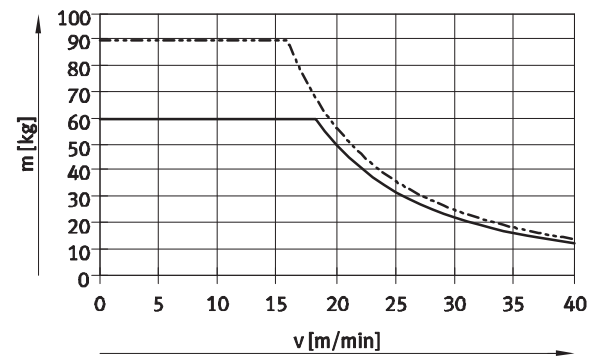

- DFSP-40/DFSP-Q-40
- - - DFSP-50/DFSP-Q-50

DFSP-Q-...-R – with roller

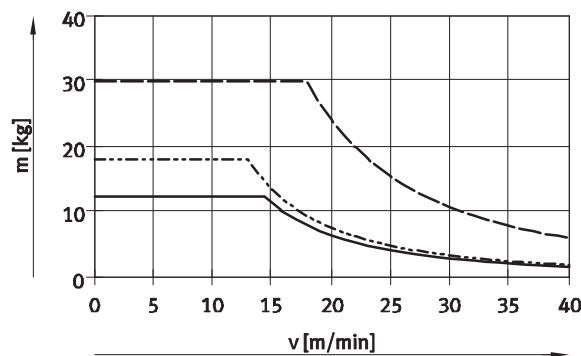

- DFSP-Q-16-R
- - - DFSP-Q-20-R
- · - DFSP-Q-32-R

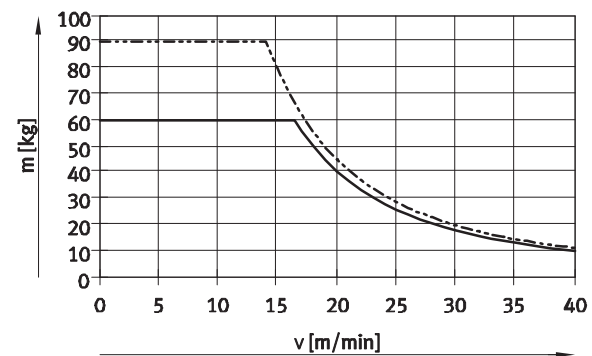

- DFSP-Q-40-R
- - - DFSP-Q-50-R

Stopper cylinders DFSP

Technical data



Permissible lateral force F on the advanced piston rod during switching operation

The "permissible lateral force during switching operation" refers to the force which is still applied perpendicularly to the direction of movement of the piston rod even after the end of

the impact or braking process, e.g. as a result of belts that are still running or the downhill force of a steep raceway. The force has a static effect. The

stopper must operate under this force. To ensure the function of the cylinder, a minimum pressure must be applied → 6

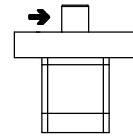

→ = Direction of lateral force

Piston Ø		16	20	32	40	50
DFSP-...	[N]	130	210	570	950	1,500
DFSP-Q-...	[N]	130	210	570	950	1,500
DFSP-Q-...-R	[N]	100	160	420	750	1,200

Permissible lateral force F during the switching operation as a function of the pressure p

In order to overcome the bearing friction, sufficient compressed air must be applied when switching under pressure.

If the compressed air is below 6 bar, the following graphs and the minimum operating pressure should be observed.

Note
Selection aid → 22

DFSP-... / DFSP-Q-... – with trunnion

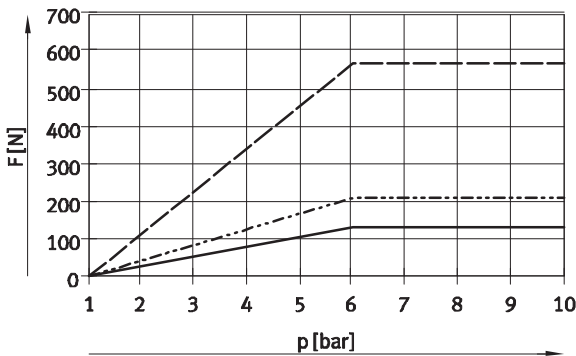

— DFSP-16
- - - DFSP-20
- · - DFSP-32

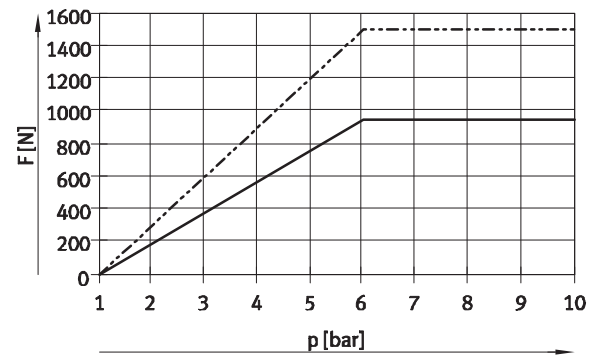

— DFSP-40
- - - DFSP-50

DFSP-Q-...-R – with roller

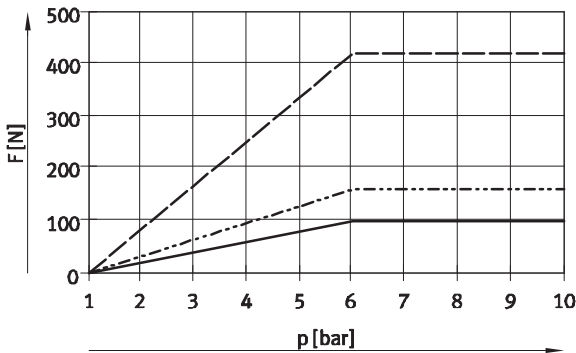

— DFSP-Q-16-R
- - - DFSP-Q-20-R
- · - DFSP-Q-32-R

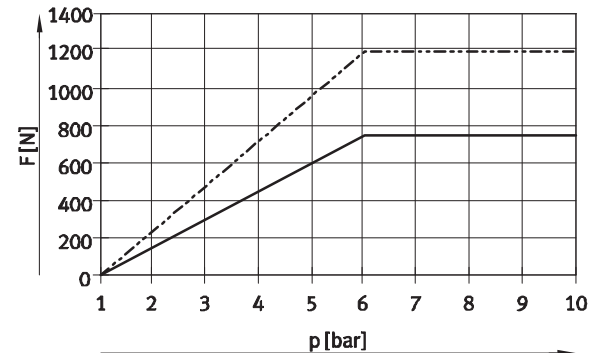

— DFSP-Q-40-R
- - - DFSP-Q-50-R

Stopper cylinders DFSP

Technical data

Bearing clearance of the piston rod when subjected to lateral force F

The specifications are valid for the following conditions:

- In new condition
- Without compressed air
- Max. lateral force
- Advanced piston rod

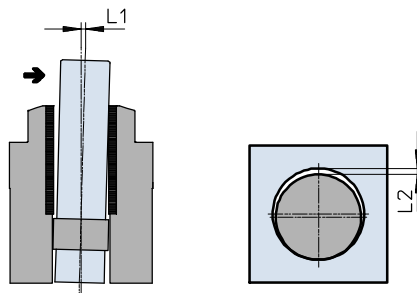

Piston Ø		16	20	32	40	50
Dimension L1						
DFSP-...	[mm]	±0.2	±0.25	±0.25	±0.3	±0.3
DFSP-Q-...	[mm]	±0.25	±0.3	±0.3	±0.3	±0.35
Dimension L2						
Absolute bearing clearance	[mm]	±0.1	±0.12	±0.14	±0.14	±0.17

Spring return force F as a function of stroke l

- For single-acting cylinders, the effective force is reduced compared to the theoretical force by the values for frictional and spring force
- The frictional force must be smaller than the spring force
- The friction depends on the mounting position and the type of load involved
- Single-acting cylinders should as far as possible be operated without lateral forces when advancing (spring force).

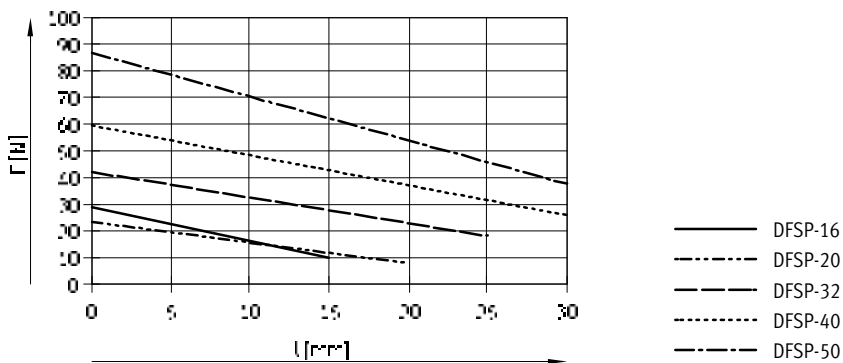

Stopper cylinders DFSP

Technical data

FESTO

Dimensions

Download CAD data → www.festo.com

DFSP-... – with trunnion

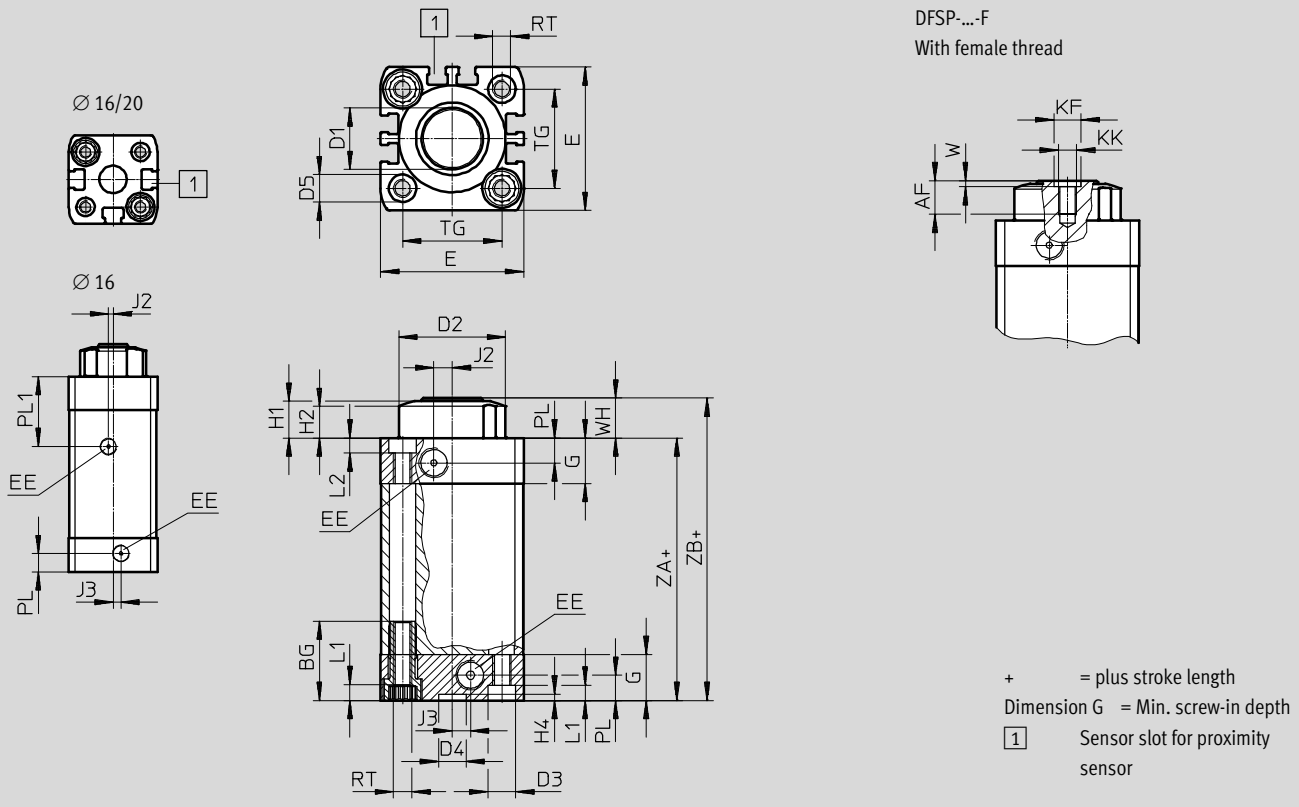

Ø	AF	BG	D1	D2	D3	D4	D5	E	EE	G	H1	H2	H4	J2
[mm]	min.	min.	Ø	Ø	Ø	Ø	Ø	+0.3			±0.3	±0.3	+0.1	
16	6	17	10	21.5	6	9	6	29	M5	11	9.5	8.4	2.1	1.5
20	6	19.5	12	25	9	9	7.5	35.5	M5	12	9.5	8.4	2.1	4
32	11	26	20	35	9	9	9	47	G $\frac{1}{8}$	15	12	10.5	2.1	6
40	14.5	26	25	43	9	9	9	54.5	G $\frac{1}{8}$	15	12.5	10.5	2.1	8
50	14.5	27	32	51	12	12	10.5	65.5	G $\frac{1}{8}$	15	14.5	12.5	2.6	10

Ø	J3	KF	KK	L1	L2	PL	PL1	RT	TG	W	WH	ZA	ZB
[mm]		Ø		+0.2	+0.2	+0.2	±0.4		±0.2	+0.1	±0.7	±0.3	±0.7
16	2.6	5	M3	3.5	3	6	23	M4	18	1.2	10.5	49	59.5
20	2.6	5	M3	5	4	6	–	M5	22	1.2	10.5	53.5	64
32	6	9	M6	5	5	8.2	–	M6	32.5	2	13	61	74
40	8	12	M8	5	5	8.2	–	M6	38	2.5	13.5	66.5	80
50	8	12	M8	5	4.2	8.2	–	M8	46.5	2.5	15.5	65.5	81

Stopper cylinders DFSP

Technical data

FESTO

Dimensions

Download CAD data → www.festo.com

DFSP-Q-... – with trunnion and protection against rotation

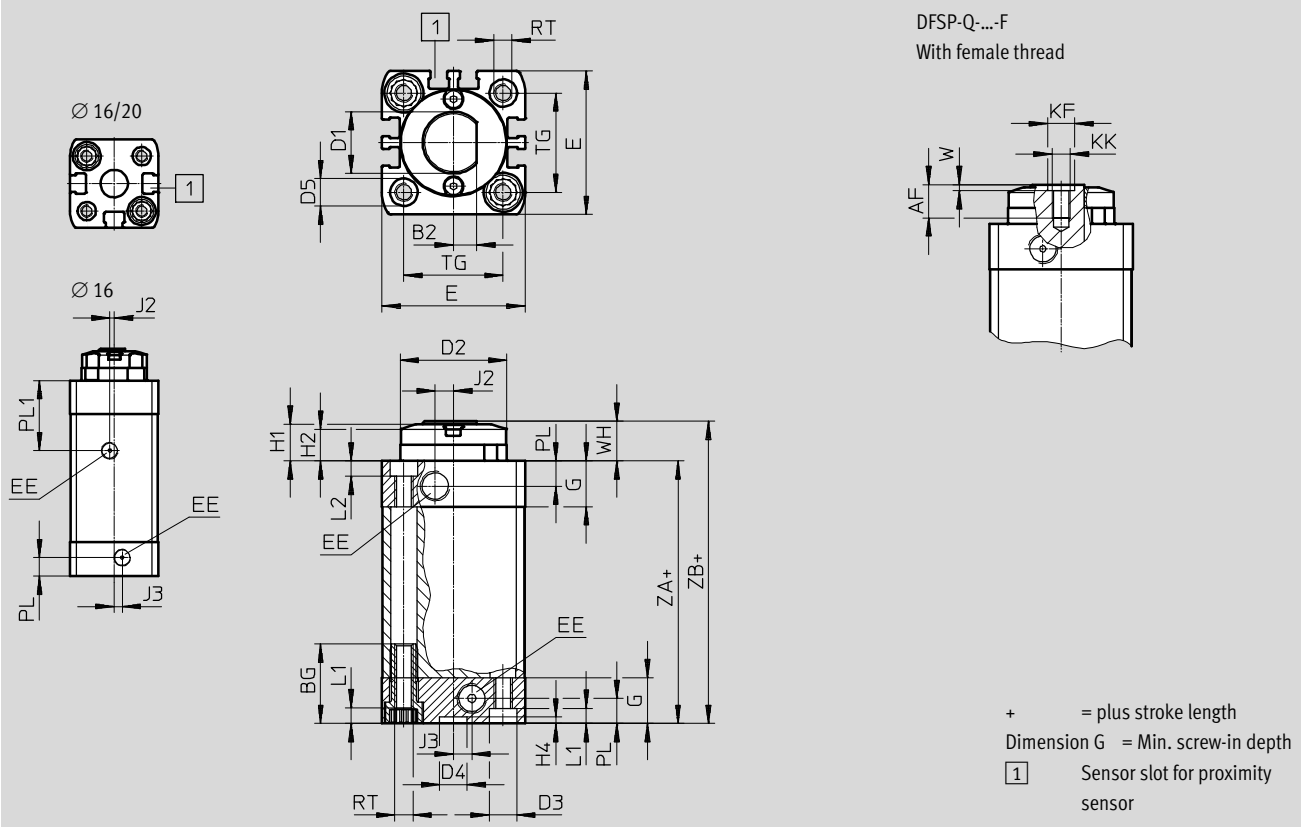

∅	AF	B2	BG	D1	D2	D3	D4	D5	E	EE	G	H1	H2	H4
[mm]	min.	-0.15	min.	∅	∅ f8	∅ F9	∅ H9	∅ F9	+0.3			±0.3	±0.3	+0.1
16	6	3.5	17	10	21.5	6	9	6	29	M5	11	9.5	8.4	2.1
20	6	4	19.5	12	25	9	9	7.5	35.5	M5	12	9.5	8.4	2.1
32	11	7.5	26	20	35	9	9	9	47	G $\frac{1}{8}$	15	12	10.5	2.1
40	14.5	9.5	26	25	43	9	9	9	54.5	G $\frac{1}{8}$	15	12.5	10.5	2.1
50	14.5	12	27	32	51	12	12	10.5	65.5	G $\frac{1}{8}$	15	14.5	12.5	2.6

∅	J2	J3	KF	KK	L1	L2	PL	PL1	RT	TG	W	WH	ZA	ZB
[mm]			∅ H7		+0.2	+0.2	+0.2	±0.4		±0.2	+0.1	±0.7	±0.3	±0.7
16	1.5	2.6	5	M3	3.5	3	6	23	M4	18	1.2	10.5	49	59.5
20	4	2.6	5	M3	5	4	6	-	M5	22	1.2	10.5	53.5	64
32	6	6	9	M6	5	5	8.2	-	M6	32.5	2	13	61	74
40	8	8	12	M8	5	5	8.2	-	M6	38	2.5	13.5	66.5	80
50	10	8	12	M8	5	4.2	8.2	-	M8	46.5	2.5	15.5	65.5	81

Stopper cylinders DFSP

Technical data

FESTO

Dimensions

Download CAD data → www.festo.com

DFSP-Q-...-R – with roller and protection against rotation

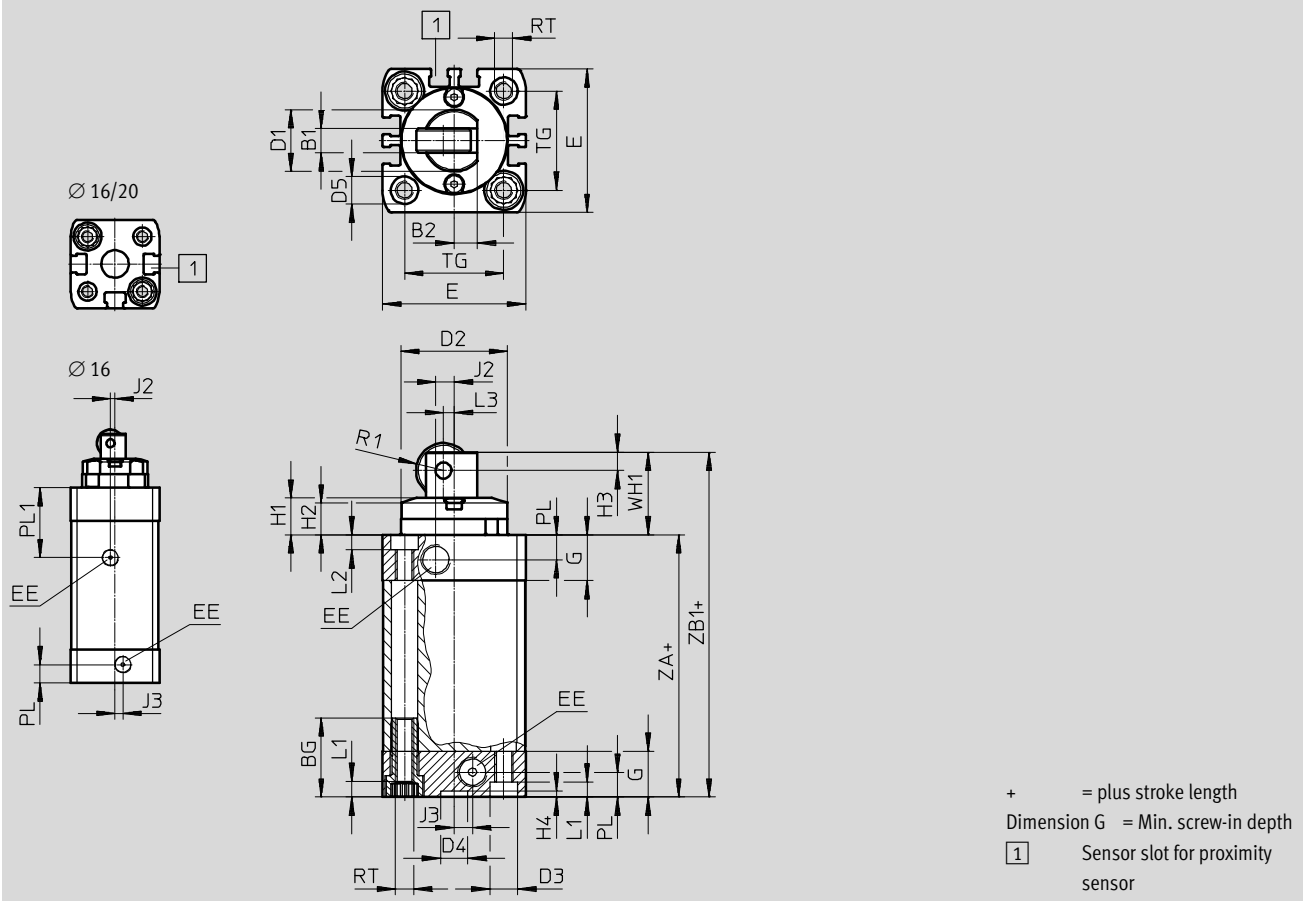

∅	B1	B2	BG	D1	D2	D3	D4	D5	E	EE	G	H1	H2	H3
[mm]	-0.2	-0.15	min.	∅	∅ f8	∅ F9	∅ H9	∅ F9	+0.3			±0.3	±0.3	
16	3.5	3.5	17	10	21.5	6	9	6	29	M5	11	9.5	8.4	3
20	4	4	19.5	12	25	9	9	7.5	35.5	M5	12	9.5	8.4	3
32	8	7.5	26	20	35	9	9	9	47	G $\frac{1}{8}$	15	12	10.5	6
40	8	9.5	26	25	43	9	9	9	54.5	G $\frac{1}{8}$	15	12.5	10.5	7
50	10	12	27	32	51	12	12	10.5	65.5	G $\frac{1}{8}$	15	14.5	12.5	7.5

∅	H4	J2	J3	L1	L2	L3	PL	PL1	R1	RT	TG	WH1	ZA	ZB1
[mm]	+0.1			+0.2	+0.2		+0.2	±0.4			±0.2	±0.7	±0.3	±0.7
16	2.1	1.5	2.6	3.5	3	1.5	6	23	4.5	M4	18	17.5	49	66.5
20	2.1	4	2.6	5	4	2	6	-	5	M5	22	17.5	53.5	71
32	2.1	6	6	5	5	3.5	8.2	-	9	M6	32.5	27	61	88
40	2.1	8	8	5	5	5	8.2	-	11	M6	38	30.5	66.5	97
50	2.6	10	8	5	4.2	7	8.2	-	12.5	M8	46.5	34.5	65.5	100

Stopper cylinders DFSP

Technical data

FESTO

Ordering data									
Stroke [mm]	Piston rod version			Function			Protection against rotation	Part no.	Type
	With trunnion	With trunnion and female thread	With roller	Double-acting with spring, pulling	Double-acting without spring	Single-acting, pulling			
Piston \varnothing 16									
10	■			■				576056	DFSP-16-10-S-PA
	■				■			576058	DFSP-16-10-DS-PA
	■					■		576060	DFSP-16-10-PS-PA
		■		■				576062	DFSP-16-10-F-PA
		■			■			576064	DFSP-16-10-DF-PA
		■				■		576066	DFSP-16-10-PF-PA
		■			■		■	576068	DFSP-Q-16-10-DF-PA
			■			■	■	576070	DFSP-Q-16-10-PR-PA
15	■			■				576057	DFSP-16-15-S-PA
	■				■			576059	DFSP-16-15-DS-PA
	■					■		576061	DFSP-16-15-PS-PA
		■		■				576063	DFSP-16-15-F-PA
		■			■			576065	DFSP-16-15-DF-PA
		■				■		576067	DFSP-16-15-PF-PA
		■			■		■	576069	DFSP-Q-16-15-DF-PA
			■			■	■	576071	DFSP-Q-16-15-PR-PA
Piston \varnothing 20									
10	■			■				576072	DFSP-20-10-S-PA
	■				■			576075	DFSP-20-10-DS-PA
	■					■		576078	DFSP-20-10-PS-PA
		■		■				576081	DFSP-20-10-F-PA
		■			■			576084	DFSP-20-10-DF-PA
		■				■		576087	DFSP-20-10-PF-PA
		■			■		■	576090	DFSP-Q-20-10-DF-PA
			■			■	■	576093	DFSP-Q-20-10-PR-PA
15	■			■				576073	DFSP-20-15-S-PA
	■				■			576076	DFSP-20-15-DS-PA
	■					■		576079	DFSP-20-15-PS-PA
		■		■				576082	DFSP-20-15-F-PA
		■			■			576085	DFSP-20-15-DF-PA
		■				■		576088	DFSP-20-15-PF-PA
		■			■		■	576091	DFSP-Q-20-15-DF-PA
			■			■	■	576094	DFSP-Q-20-15-PR-PA
20	■			■				576074	DFSP-20-20-S-PA
	■				■			576077	DFSP-20-20-DS-PA
	■					■		576080	DFSP-20-20-PS-PA
		■		■				576083	DFSP-20-20-F-PA
		■			■			576086	DFSP-20-20-DF-PA
		■				■		576089	DFSP-20-20-PF-PA
		■			■		■	576092	DFSP-Q-20-20-DF-PA
			■			■	■	576095	DFSP-Q-20-20-PR-PA

-  - Note

Additional variants → 19

Stopper cylinders DFSP

Technical data

FESTO

Ordering data									
Stroke [mm]	Piston rod version			Function			Protection against rotation	Part no.	Type
	With trunnion	With trunnion and female thread	With roller	Double-acting with spring, pulling	Double-acting without spring	Single-acting, pulling			
Piston \varnothing 32									
15	■			■				576096	DFSP-32-15-S-PA
	■				■			576099	DFSP-32-15-DS-PA
	■					■		576102	DFSP-32-15-PS-PA
		■		■				576105	DFSP-32-15-F-PA
		■			■			576108	DFSP-32-15-DF-PA
		■				■		576111	DFSP-32-15-PF-PA
		■			■		■	576114	DFSP-Q-32-15-DF-PA
			■			■	■	576117	DFSP-Q-32-15-PR-PA
20	■			■				576097	DFSP-32-20-S-PA
	■				■			576100	DFSP-32-20-DS-PA
	■					■		576103	DFSP-32-20-PS-PA
		■		■				576106	DFSP-32-20-F-PA
		■			■			576109	DFSP-32-20-DF-PA
		■				■		576112	DFSP-32-20-PF-PA
		■		■	■		■	576115	DFSP-Q-32-20-DF-PA
			■			■	■	576118	DFSP-Q-32-20-PR-PA
25	■			■				576098	DFSP-32-25-S-PA
	■				■			576101	DFSP-32-25-DS-PA
	■					■		576104	DFSP-32-25-PS-PA
		■		■				576107	DFSP-32-25-F-PA
		■			■			576110	DFSP-32-25-DF-PA
		■				■		576113	DFSP-32-25-PF-PA
		■		■	■		■	576116	DFSP-Q-32-25-DF-PA
			■			■	■	576119	DFSP-Q-32-25-PR-PA

-  - Note
Additional variants → 19

Stopper cylinders DFSP

Technical data

Ordering data									
Stroke [mm]	Piston rod version			Function			Protection against rotation	Part no.	Type
	With trunnion	With trunnion and female thread	With roller	Double-acting with spring, pulling	Double-acting without spring	Single-acting, pulling			
Piston \varnothing 40									
20	■			■				576120	DFSP-40-20-S-PA
	■				■			576123	DFSP-40-20-DS-PA
	■					■		576126	DFSP-40-20-PS-PA
		■		■				576129	DFSP-40-20-F-PA
		■			■			576132	DFSP-40-20-DF-PA
		■				■		576135	DFSP-40-20-PF-PA
		■			■		■	576138	DFSP-Q-40-20-DF-PA
			■			■	■	576141	DFSP-Q-40-20-PR-PA
25	■			■				576121	DFSP-40-25-S-PA
	■				■			576124	DFSP-40-25-DS-PA
	■					■		576127	DFSP-40-25-PS-PA
		■		■				576130	DFSP-40-25-F-PA
		■			■			576133	DFSP-40-25-DF-PA
		■				■		576136	DFSP-40-25-PF-PA
		■		■	■		■	576139	DFSP-Q-40-25-DF-PA
			■			■	■	576142	DFSP-Q-40-25-PR-PA
30	■			■				576122	DFSP-40-30-S-PA
	■				■			576125	DFSP-40-30-DS-PA
	■					■		576128	DFSP-40-30-PS-PA
		■		■				576131	DFSP-40-30-F-PA
		■			■			576134	DFSP-40-30-DF-PA
		■				■		576137	DFSP-40-30-PF-PA
		■		■	■		■	576140	DFSP-Q-40-30-DF-PA
			■			■	■	576143	DFSP-Q-40-30-PR-PA

 Note

Additional variants → 19

Stopper cylinders DFSP

Technical data

FESTO

Ordering data									
Stroke [mm]	Piston rod version			Function			Protection against rotation	Part no.	Type
	With trunnion	With trunnion and female thread	With roller	Double-acting with spring, pulling	Double-acting without spring	Single-acting, pulling			
Piston \varnothing 50									
20	■			■				576144	DFSP-50-20-S-PA
	■				■			576147	DFSP-50-20-DS-PA
	■					■		576150	DFSP-50-20-PS-PA
		■		■				576153	DFSP-50-20-F-PA
		■			■			576156	DFSP-50-20-DF-PA
		■				■		576159	DFSP-50-20-PF-PA
		■			■		■	576162	DFSP-Q-50-20-DF-PA
			■			■	■	576165	DFSP-Q-50-20-PR-PA
25	■			■				576145	DFSP-50-25-S-PA
	■				■			576148	DFSP-50-25-DS-PA
	■					■		576151	DFSP-50-25-PS-PA
		■		■				576154	DFSP-50-25-F-PA
		■			■			576157	DFSP-50-25-DF-PA
		■				■		576160	DFSP-50-25-PF-PA
		■			■		■	576163	DFSP-Q-50-25-DF-PA
			■			■	■	576166	DFSP-Q-50-25-PR-PA
30	■			■				576146	DFSP-50-30-S-PA
	■				■			576149	DFSP-50-30-DS-PA
	■					■		576152	DFSP-50-30-PS-PA
		■		■				576155	DFSP-50-30-F-PA
		■			■			576158	DFSP-50-30-DF-PA
		■				■		576161	DFSP-50-30-PF-PA
		■			■		■	576164	DFSP-Q-50-30-DF-PA
			■			■	■	576167	DFSP-Q-50-30-PR-PA

-  - Note
Additional variants → 19

Stopper cylinders DFSP



Ordering data – Modular product

Ordering table								
Size	16	20	32	40	50	Condi- tions	Code	Entry code
M Module No.	575166	575167	575168	575169	575170			
Function	Stopper cylinder						DFSP	DFSP
O Protection against rotation	None							
	With protection against rotation						-Q	
M Piston Ø [mm]	16	20	32	40	50		-...	
Stroke [mm]	10, 15	10, 15, 20	15, 20, 25	20, 25, 30	20, 25, 30		-...	
	5 ... 15	5 ... 20	5 ... 25	5 ... 30	5 ... 30			
O Function	Double-acting with spring, pulling							
	Double-acting without spring						-D	
	Single-acting with spring, pulling						-P	
M Piston rod version	Standard						S	
	With female thread						F	
	With roller					1	R	
Cushioning	Elastic cushioning rings/plates at both ends						-P	P
Position sensing	Via proximity sensor						A	A

1 R Only with 10, 15, 20, 25, 30 mm stroke
Only with protection against rotation Q

Transfer order code

DFSP - - - - - - **P** **A**

Stopper cylinders DFSP

Accessories

FESTO

Flange mounting DAMF-F7

Materials:

Galvanised steel

Free of copper and PTFE

RoHS-compliant

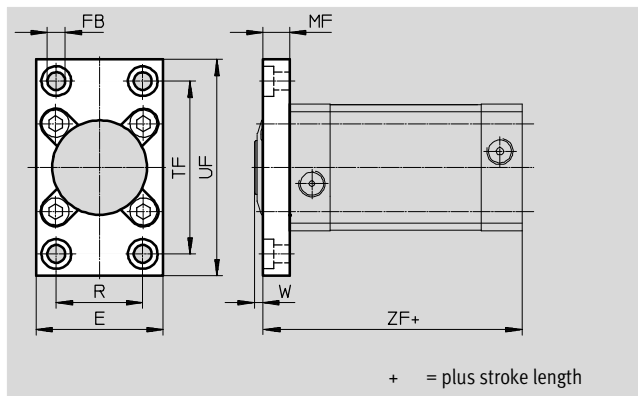

Dimensions and ordering data								
For \varnothing	E	FB \varnothing	MF	R	TF	UF	W	ZF
[mm]			± 0.2	± 0.1	± 0.1		± 0.9	± 0.5
16	29	5.5	8	17	43	55	2.5	57
20	35.5	5.5	8	22	56	70	2.5	61.5
32	47	6.6	10	32	64	80	3	71
40	54.5	6.6	10	36	72	90	3.5	76.5
50	65	9	12	45	90	110	3.5	77.5

For \varnothing	Screws ¹⁾ (4x)	Tightening torque	Weight	Part no.	Type
[mm]		[Nm]			
16	DIN 912-M4x16-8.8	2.5	69	1405169	DAMF-F7-16
20	DIN 6912-M5x20-8.8	4.8	119	1405193	DAMF-F7-20
32	DIN 6912-M6x25-8.8	8	212	1405211	DAMF-F7-32
40	DIN 6912-M6x25-10.9	11	263	1405218	DAMF-F7-40
50	DIN 6912-M8x25-8.8	15	449	1405225	DAMF-F7-50

1) The screws are included in the scope of delivery of the flange mounting.

Stopper cylinders DFSP

Accessories

FESTO

Ordering data – Centring sleeves					
	For \varnothing	Description	Part no.	Type	PU ¹⁾
	16, 20	For the precise fitting on the piston rod with female thread	189652	ZBH-5	10
	32		150927	ZBH-9	
	40, 50		189653	ZBH-12	
	16, 20, 32, 40	For the precise fitting of the stopper cylinder to the end cap	150927	ZBH-9	
	50		189653	ZBH-12	

1) Packaging unit

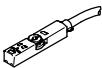
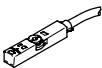
Ordering data – Proximity sensor for T-slot, magneto-resistive						Technical data → Internet: smt
	Type of mounting	Switching output	Electrical connection	Cable length [m]	Part no.	Type
N/O contact						
	Insertable in the slot from above, flush with the cylinder profile, short design	PNP	Cable, 3-wire	2.5	574335	SMT-8M-A-PS-24V-E-2,5-OE
			Plug M8x1, 3-pin	0.3	574334	SMT-8M-A-PS-24V-E-0,3-M8D
			Plug M12x1, 3-pin	0.3	574337	SMT-8M-A-PS-24V-E-0,3-M12
		NPN	Cable, 3-wire	2.5	574338	SMT-8M-A-NS-24V-E-2,5-OE
Plug M8x1, 3-pin	0.3		574339	SMT-8M-A-NS-24V-E-0,3-M8D		
N/C contact						
	Insertable in the slot from above, flush with the cylinder profile, short design	PNP	Cable, 3-wire	7.5	574340	SMT-8M-A-PO-24V-E-7,5-OE

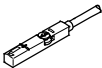
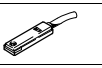
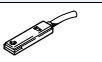
Ordering data – Proximity sensors for T-slot, magnetic reed						Technical data → Internet: sme
	Type of mounting	Switching output	Electrical connection	Cable length [m]	Part no.	Type
N/O contact						
	Insertable in the slot from above, flush with the cylinder profile	Contacting	Cable, 3-wire	2.5	543 862	SME-8M-DS-24V-K-2,5-OE
				5.0	543 863	SME-8M-DS-24V-K-5,0-OE
			Cable, 2-wire	2.5	543 872	SME-8M-ZS-24V-K-2,5-OE
				Plug M8x1, 3-pin	0.3	543 861
	Insertable in the slot lengthwise, flush with the cylinder profile	Contacting	Cable, 3-wire	2.5	150 855	SME-8-K-LED-24
			Plug M8x1, 3-pin	0.3	150 857	SME-8-S-LED-24
N/C contact						
	Insertable in the slot lengthwise, flush with the cylinder profile	Contacting	Cable, 3-wire	7.5	160 251	SME-8-O-K-LED-24

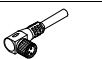
Ordering data – Connecting cables						Technical data → Internet: nebu
	Electrical connection, left	Electrical connection, right	Cable length [m]	Part no.	Type	
	Straight socket, M8x1, 3-pin	Cable, open end, 3-wire	2.5	541 333	NEBU-M8G3-K-2.5-LE3	
			5	541 334	NEBU-M8G3-K-5-LE3	
	Angled socket, M8x1, 3-pin	Cable, open end, 3-wire	2.5	541 338	NEBU-M8W3-K-2.5-LE3	
			5	541 341	NEBU-M8W3-K-5-LE3	

Ordering data – Slot cover for T-slot					
	Mounting	Length [m]	Part no.	Type	
	Inserted from above	2x 0.5	151680	ABP-5-S	

Stopper cylinders DFSP

Technical data

Selection aid

Stopping a pallet

The stopper cylinder is used to brake an individual pallet.

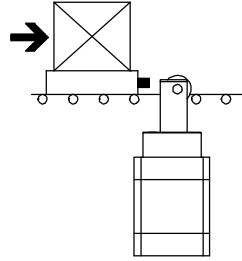

Example

Given:

Friction factor $\mu = 0.1$

Conveyor speed $v = 15 \text{ m/min}$

Pallet with workpiece $m = 40 \text{ kg}$

Operating pressure $p = 6 \text{ bar}$

Spring travel of the pallet buffer $s_F = 1 \text{ mm}$

Selection: stopper cylinders DFSP-Q-40-...-R

1. Checking the permissible load

The maximum permissible load at a conveyor speed of 15 m/min is 60 kg. This means that the total permissible load for the pallet and the workpiece is 40 kg.

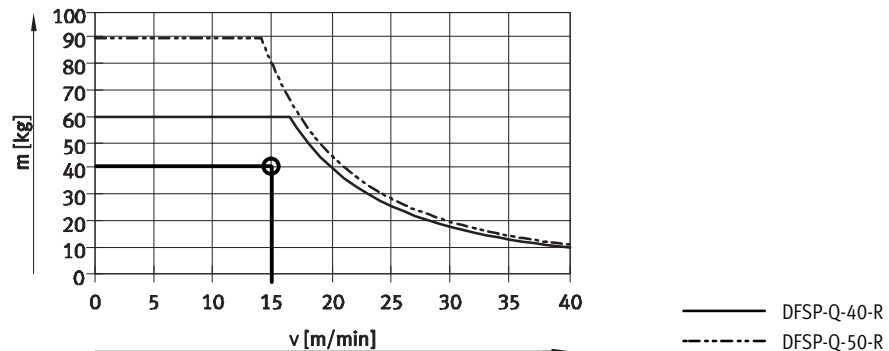

2. Checking the permissible lateral force during the switching operation

Lateral force $F_Q = \text{frictional force}$

F_{Friction}

$$F_{\text{Friction}} = \mu \times m \times g$$

$$= 0.1 \times 40 \text{ kg} \times 9.81 \text{ m/s}^2$$

$$= \text{approx. } 40 \text{ N}$$

The maximum permissible lateral force at an operating pressure of 6 bar is 750 N.

This means that a lateral force of 40 N is permissible.

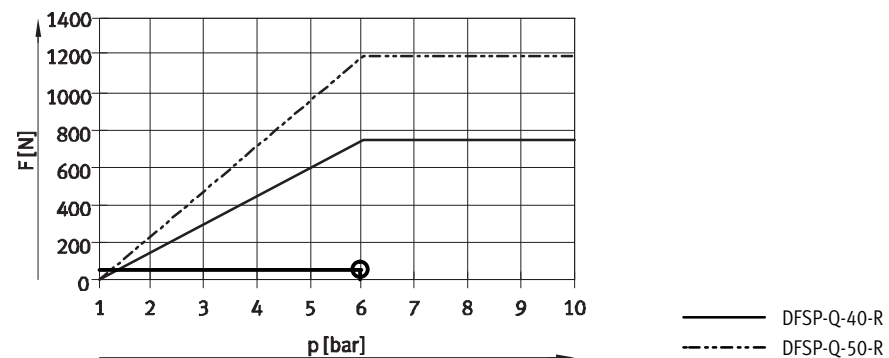

Stopper cylinders DFSP

Technical data

Selection aid

Stopping or separating several pallets

The stopper cylinder is used to separate pallets. Further pallets accumulate behind the pallets already resting against the stopper cylinder. It is therefore vital that a buffer is mounted between the pallets (e.g. elastomer elements).

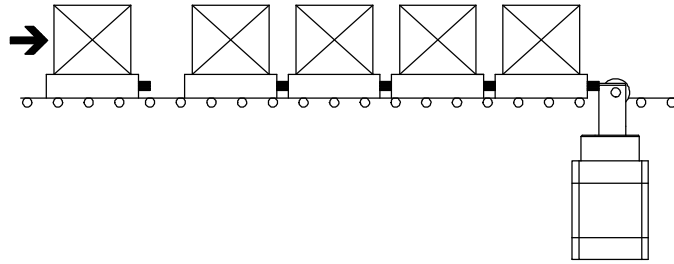

Example

Given:

Friction factor $\mu = 0.1$

Conveyor speed $v = 15 \text{ m/min}$

Pallet with workpiece $m = 40 \text{ kg}$

Operating pressure $p = 6 \text{ bar}$

Maximum number of pallets accumulating simultaneously $n_{\text{Group}} = 1$

Maximum number of all queued pallets $n_{\text{Queue}} = 5$

Maximum number of all advancing pallets $n_{\text{Queue-1}} = 4$

Spring travel of the pallet buffer $s_F = 1 \text{ mm}$

Selection: stopper cylinders DFSP-Q-40-...-R

1. Checking the permissible load of the first pallet

The maximum permissible load at a conveyor speed of 15 m/min is 60 kg. This means that a total load of 40 kg for the pallet and the workpiece is permissible.

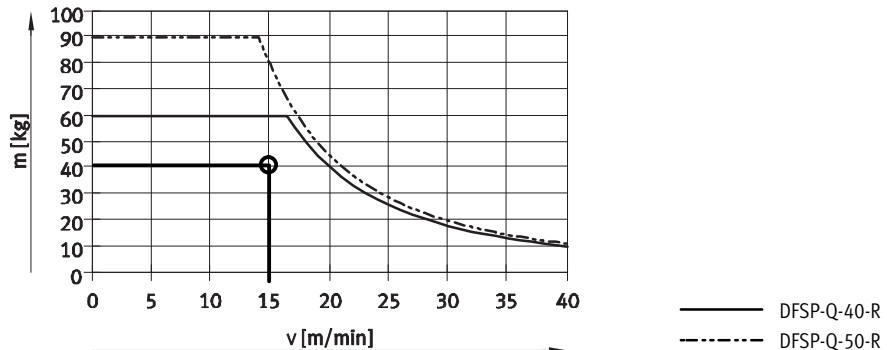

2a. Calculation of the maximum permissible impact force when pallets accumulate behind a pallet resting against the stopper cylinder

For DFSP-Q-40-...-R, the maximum permissible impact force is 4,500 N. This means that with a total force of 2,700 N, the number of pallets is permissible.

Impact force calculation:

$$F_{\text{Impact}} = \frac{(n_{\text{Group}} \times m) \times v^2}{s_F} = \frac{(1 \times 40\text{kg}) \times (15\text{m}/60\text{s})^2}{0,001\text{m}} = \text{ca.}2500\text{N}$$

Frictional force:

$$F_{\text{Friction}} = \mu \times (n_{\text{Queue}} \times m) \times g = 0,1 \times (5 \times 40\text{kg}) \times 9,81\text{m/s}^2 = \text{ca.}200\text{N}$$

Max. total force:

$$F_{\text{total}} = F_{\text{Impact}} + F_{\text{Friction}} = 2500\text{N} + 200\text{N} = 2700\text{N}$$

Stopper cylinders DFSP

Technical data

Selection aid

2b. Checking the permissible lateral force during the switching operation

Lateral force F_Q = frictional force

$F_{Friction}$

$F_{Friction} = 200 \text{ N}$

The maximum permissible lateral force at an operating pressure of 6 bar is 750 N.

This means that a lateral force of 200 N is permissible.

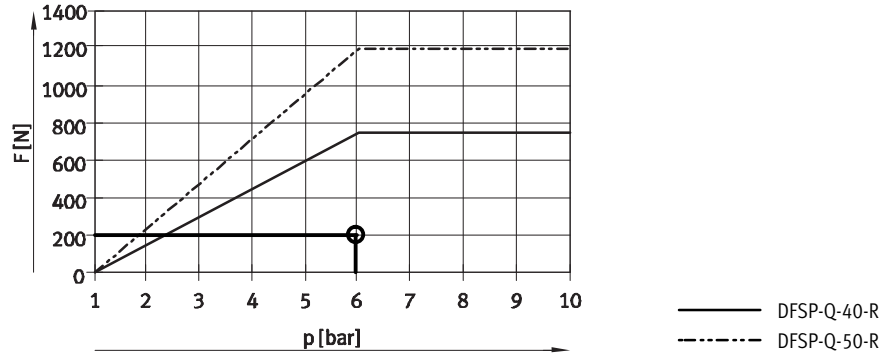

3. Separating and advancing the pallets

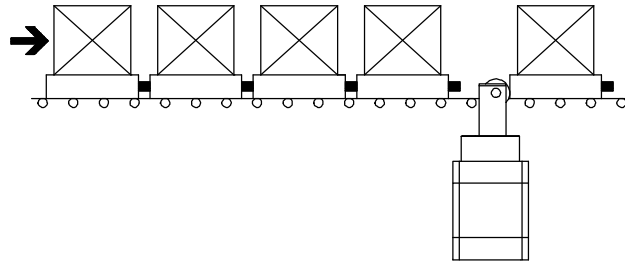

For the DFSP-Q-40-...-R, the maximum permissible load at a conveyor speed of 15 m/min is 60 kg.

The total load of the 4 pallets advancing on the stopper cylinder is 160 kg. The next largest stopper cylinder is therefore not permissible for this application as a max. of 80 kg at a speed of 15 m/min is permissible here.

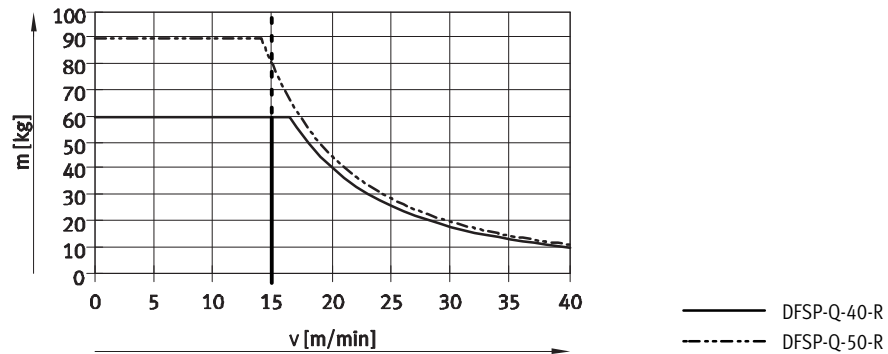

Max. total load:

$$m_{total} = n_{Queue-1} \times m = 4 \times 40\text{kg} = 160\text{kg}$$

Result

When using stopper cylinders DFSP-Q-50-...-R, max. 2 advancing pallets may accumulate simultaneously.

Max. total load:

$$m_{total} = n_{Queue-1} \times m = 2 \times 40\text{kg} = 80\text{kg}$$

Product Range and Company Overview

A Complete Suite and Company Overview

Our experienced engineers provide complete support at every stage of your development process, including: conceptualization, analysis, engineering, design, assembly, documentation, validation, and production.



Custom Automation Components
Complete custom engineered solutions



Custom Control Cabinets
Comprehensive engineering support and on-site services



Complete Systems
Shipment, stocking and storage services

The Broadest Range of Automation Components

With a comprehensive line of more than 30,000 automation components, Festo is capable of solving the most complex automation requirements.



Electromechanical
Electromechanical actuators, motors, controllers & drivers



Pneumatics
Pneumatic linear and rotary actuators, valves, and air supply



PLCs and I/O Devices
PLC's, operator interfaces, sensors and I/O devices

Supporting Advanced Automation... As No One Else Can!

Festo is a leading global manufacturer of pneumatic and electromechanical systems, components and controls for industrial automation, with more than 16,000 employees in 60 national headquarters serving more than 180 countries. For more than 80 years, Festo has continuously elevated the state of manufacturing with innovations and optimized motion control solutions that deliver higher performing, more profitable automated manufacturing and processing equipment. Our dedication to the advancement of automation extends beyond technology to the education and development of current and future automation and robotics designers with simulation tools, teaching programs, and on-site services.

Quality Assurance, ISO 9001 and ISO 14001 Certifications

Festo Corporation is committed to supply all Festo products and services that will meet or exceed our customers' requirements in product quality, delivery, customer service and satisfaction.

To meet this commitment, we strive to ensure a consistent, integrated, and systematic approach to management that will meet or exceed the requirements of the ISO 9001 standard for Quality Management and the ISO 14001 standard for Environmental Management.



© Copyright 2013, Festo Corporation. While every effort is made to ensure that all dimensions and specifications are correct, Festo cannot guarantee that publications are completely free of any error, in particular typing or printing errors. Accordingly, Festo cannot be held responsible for the same. For Liability and Warranty conditions, refer to our "Terms and Conditions of Sale", available from your local Festo office. All rights reserved. No part of this publication may be reproduced, distributed, or transmitted in any form or by any means, electronic, mechanical, photocopying or otherwise, without the prior written permission of Festo. All technical data subject to change according to technical update.



Printed on recycled paper at New Horizon Graphic, Inc., FSC certified as an environmental friendly printing plant.

Festo North America

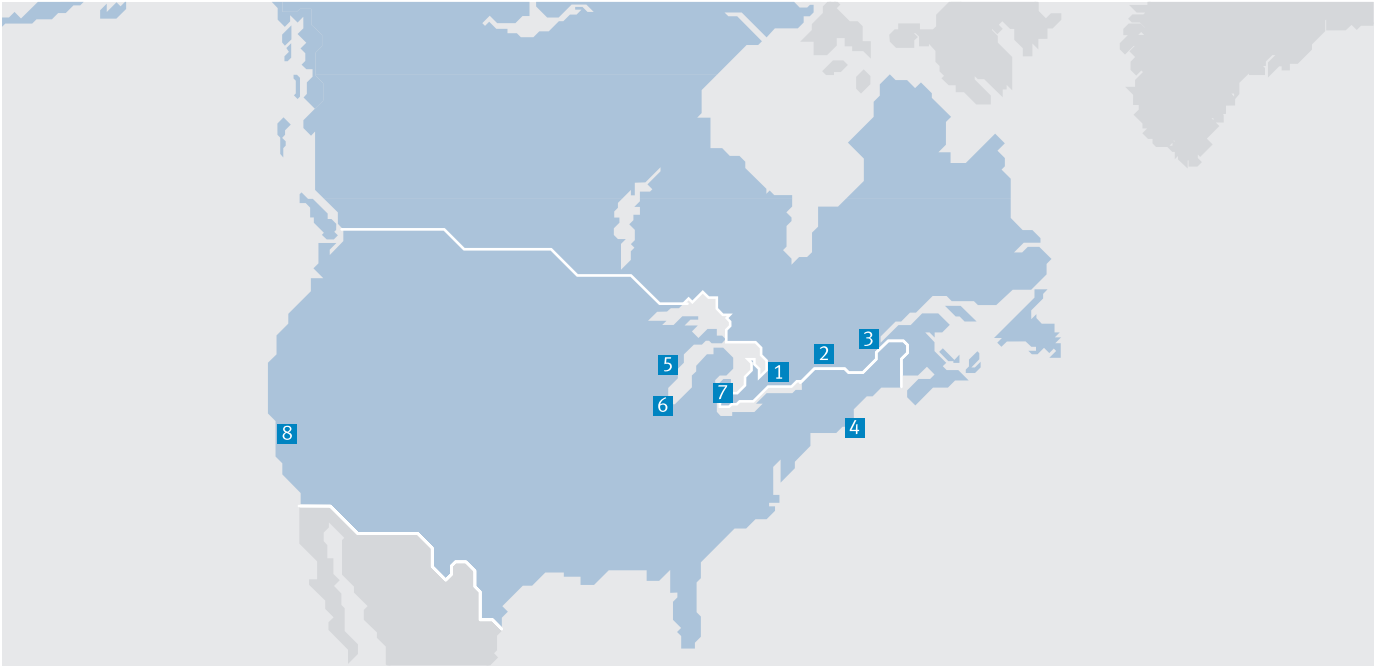

**1 Festo Canada
Headquarters
Festo Inc.**
5300 Explorer Drive
Mississauga, ON
L4W 5G4

2 Montréal
5600, Trans-Canada
Pointe-Claire, QC
H9R 1B6

3 Québec City
2930, rue Watt#117
Québec, QC
G1X 4G3



**4 Festo United States
Headquarters
Festo Corporation**
395 Moreland Road
Hauppauge, NY
11788

5 Appleton
North 922 Tower View Drive, Suite N
Greenville, WI
54942

7 Detroit
1441 West Long Lake Road
Troy, MI
48098

6 Chicago
85 W Algonquin - Suite 340
Arlington Heights, IL
60005

8 Silicon Valley
4935 Southfront Road, Suite F
Livermore, CA
94550

Festo Regional Contact Center

Canadian Customers

Commercial Support:
Tel: 1 877 GO FESTO (1 877 463 3786)
Fax: 1 877 FX FESTO (1 877 393 3786)
Email: festo.canada@ca.festo.com

Technical Support:

Tel: 1 866 GO FESTO (1 866 463 3786)
Fax: 1 877 FX FESTO (1 877 393 3786)
Email: technical.support@ca.festo.com

USA Customers

Commercial Support:
Tel: 1 800 99 FESTO (1 800 993 3786)
Fax: 1 800 96 FESTO (1 800 963 3786)
Email: customer.service@us.festo.com

Technical Support:

Tel: 1 866 GO FESTO (1 866 463 3786)
Fax: 1 800 96 FESTO (1 800 963 3786)
Email: product.support@us.festo.com