

Intermediate-position module DADM-EP



# Intermediate-position module DADM-EP

Key features

## At a glance

The intermediate-position module enables an intermediate position to be set within the stroke range of pneumatic drives. The module is mounted separately, directly next to the mini slide. A shock absorber retainer must be attached to the

movable part of the drive (e.g. the slide) so that, when advancing, the shock absorber impacts on the stop lever of the intermediate-position module. The position can be precisely set with the aid of the shock absorber.

Key features:

- Can be travelled through from the end position
- Possible to continue on directly from the intermediate position
- Owing to the symmetrical structure, the intermediate position can be approached when advancing or retracting, depending on the assembly
- Pneumatic connection possible from 2 sides
- Easy to assemble
- Position of the stop lever (pivoted in or out) can be checked using the proximity sensor

## The technology in detail

- 1 Stop lever
- 2 Pneumatic connections for pivoting in stop lever
- 3 Pneumatic connections for pivoting out stop lever
- 4 Slot for proximity sensor
- 5 Spring guiding shoe
- 6 Lateral mounting interface (2x)
- 7 Lower mounting interface (2x)

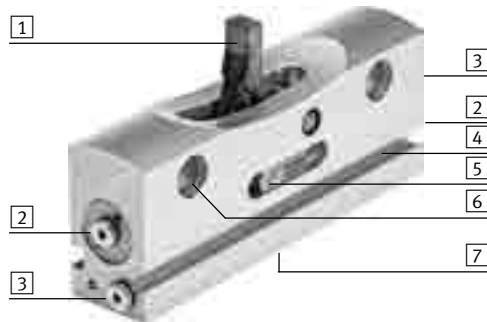

 Note  
In the unpressurised state, the spring guiding shoe can be used as manual override for pivoting the stop lever.

## Assembly using the mini slide DGSL as an example

The intermediate-position module is fastened to the mounting surface directly next to the mini slide, using 2 screws and centring sleeves. The shock absorber retainer is then fastened to the slide of the mini slide, likewise using 2 screws and centring sleeves.

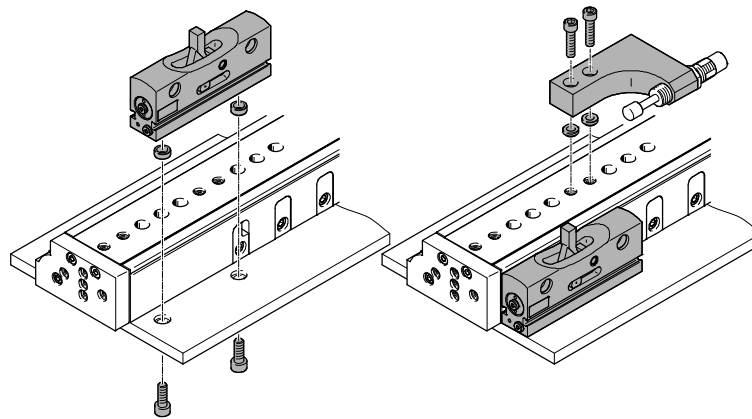

Allocation table for mini slide DGSL and intermediate-position module DADM-EP/shock absorber retainer DADP-ES

Mini slide	Intermediate-position module	Shock absorber retainer
DGSL-12	DADM-EP-G6-10	DADP-ES-G6-12
DGSL-16		DADP-ES-G6-16
DGSL-20	DADM-EP-G6-16	DADP-ES-G6-20
DGSL-25		DADP-ES-G6-25

## Precision adjustment of the intermediate position

The precision adjustment of the position is carried out using the screw-in depth of the shock absorber. The shock absorber must protrude by at least  $X = 1.5 \text{ mm}$ .

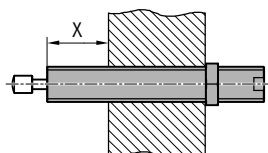

# Intermediate-position module DADM-EP

Type codes

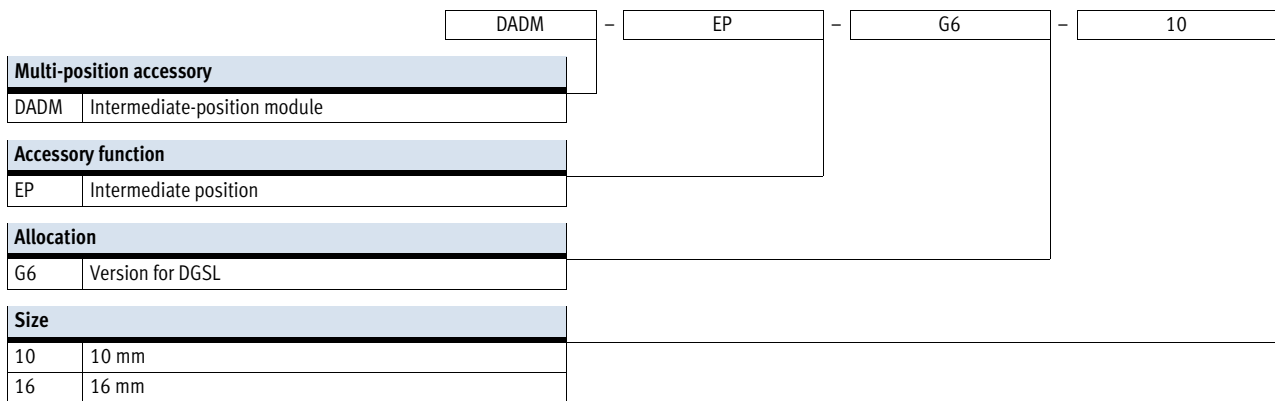

# Intermediate-position module DADM-EP

Technical data

FESTO

## Intermediate-position module DADM-EP

Materials:

Housing: Wrought aluminium alloy

Lever: High-alloy stainless steel

RoHS-compliant



General technical data			
Type		DADM-EP-G6-10	DADM-EP-G6-16
Design		Force pilot operated motion sequence	
Pneumatic connection		M3	M5
Max. stop force	[N]	500	1100
Max. impact velocity	[m/s]	0.8	0.8
Maximum pivot time	[ms]	150	
Repetition accuracy	[mm]	±0.02	
Mounting position		Any	
Position sensing		For proximity sensor	
Product weight	[g]	154	340

Operating and environmental conditions			
Operating pressure	[bar]	3 ... 6	
Operating medium		Compressed air to ISO 8573-1:2010 [7:-:-]	
Note on operating/pilot medium		Lubricated operation possible (in which case lubricated operation will always be required)	
Ambient temperature	[°C]	0 ... +60	
Corrosion resistance class CRC <sup>1)</sup>		1	

1) Corrosion resistance class CRC 1 to Festo standard FN 940070

Low corrosion stress. For dry indoor applications or transport and storage protection. Also applies to parts behind covers, in the non-visible interior area, and parts which are covered in the application (e.g. drive trunnions).

# Intermediate-position module DADM-EP

Technical data

FESTO

## Dimensions and ordering data

Download CAD data → [www.festo.com](http://www.festo.com)

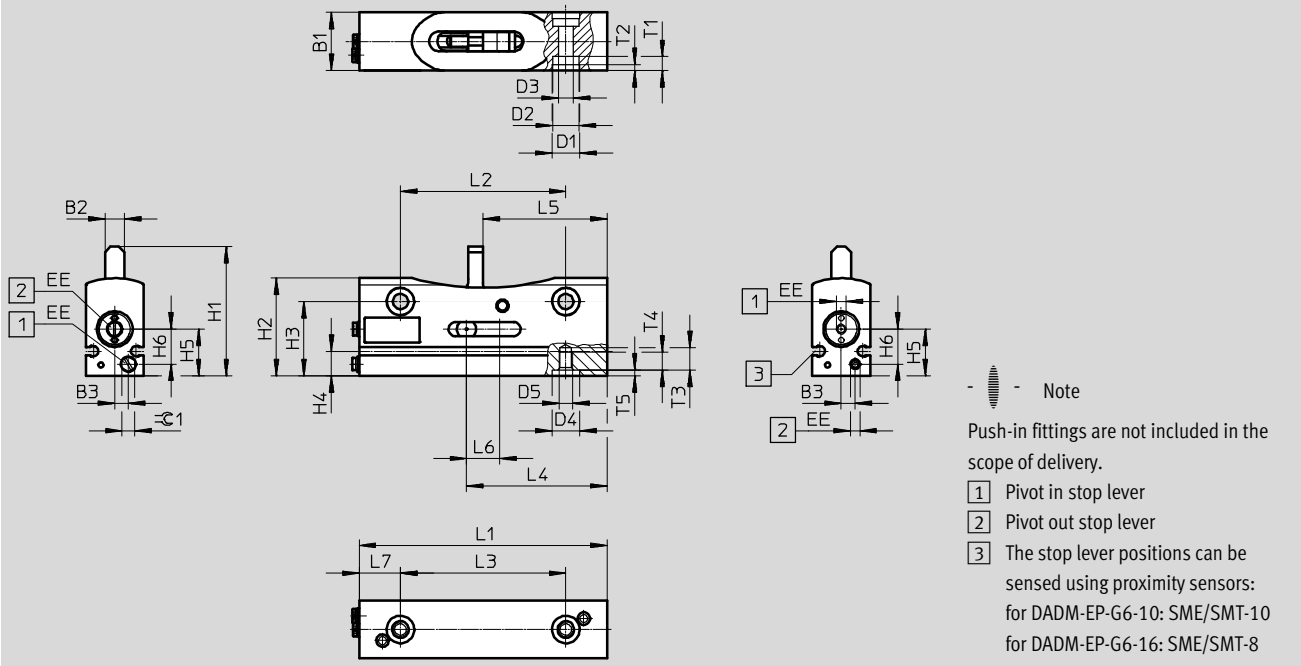



Type	B1	B2	B3	D1	D2	D3	D4	D5	EE	H1	H2
			±0.1	∅ H7	∅	∅	∅ H7				
DADM-EP-G6-10	21	7	5	10	9.5	5.5	10	M5	M3	46.9	35.4
DADM-EP-G6-16	26.5	9	5.5	12	11	6.6	12	M6	M5	65.2	47.4

Type	H3	H4	H5	H6	L1	L2	L3	L4	L5	L6	L7
	±0.1		±0.1	±0.1		±0.1	±0.1				
DADM-EP-G6-10	26.9	8.9	16.9	12.7	90	60	60	51	45	12	15
DADM-EP-G6-16	36.4	12.4	23.4	17	120	80	80	68	52.5	16	20

Type	T1	T2	T3	T4	T5	≈C1	Part No.	Type
		+0.2			+0.1			
DADM-EP-G6-10	5	2.1	8	6.5	2.1	4.5	1492072	DADM-EP-G6-10
DADM-EP-G6-16	6.8	2.1	10	8	2.1	2.5	1478121	DADM-EP-G6-16

## Ordering data

	For size	Description	Part No.	Type	PU <sup>1)</sup>
Connector sleeve ZBV <span style="float: right;">Technical data → Internet: zbv</span>					
	12, 16	For centring the intermediate position module (2 pieces included in scope of delivery for the intermediate position module)	560254	ZBV-10-9	10
Centring sleeve ZBH <span style="float: right;">Technical data → Internet: zbh</span>					
	20, 25	For centring the intermediate position module (2 pieces included in scope of delivery for the intermediate position module)	189653	ZBH-12	10

1) Packaging unit quantity

# Intermediate-position module DADM-EP

Accessories



## Shock absorber retainer DADP-ES

Materials:  
Anodised wrought aluminium alloy  
RoHS-compliant

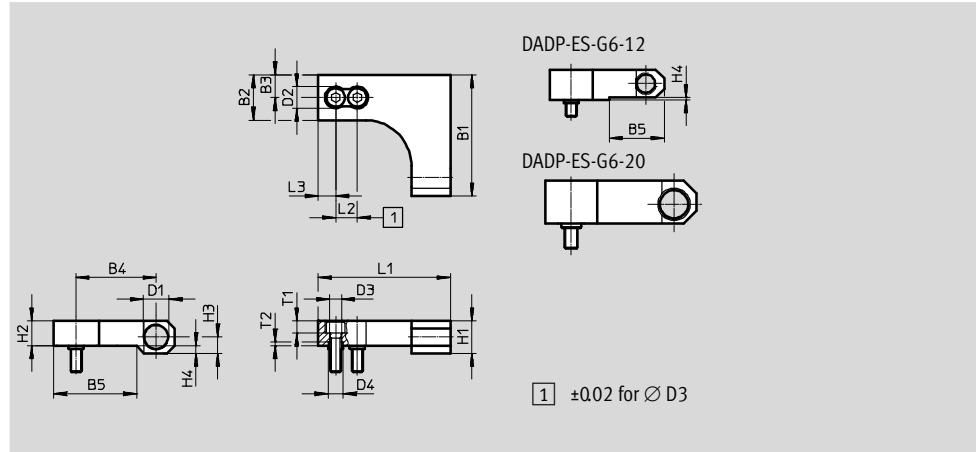

Dimensions and ordering data													
Type	B1	B2	B3	B4	B5	D1	D2 Ø	D3 Ø	D4 Ø H7	H1	H2	H3	H4
DADP-ES-G6-12	53	20	10	34.5	25.5	M10x1	10	5.5	7	13	14	6.5	1
DADP-ES-G6-16	56	21	10.5	37	39.2	M12x1	10	5.5	7	15	12.2	7.5	2.8
DADP-ES-G6-20	70	24	12	47.5	–	M14x1	11	6.6	12	20	20	9	–
DADP-ES-G6-25	80	30	15	54.5	58	M16x1	11	6.6	12	25	14	10	11

Type	L1	L2	L3	T1	T2	Max. stop force [N]	Weight [g]	Part No.	Type
DADP-ES-G6-12	65	10	10	5.7	1.6	500	80	<b>1812471</b>	<b>DADP-ES-G6-12</b>
DADP-ES-G6-16	61	10	8	5.7	1.6	500	70	<b>1812472</b>	<b>DADP-ES-G6-16</b>
DADP-ES-G6-20	85	20	10	6.4	2.6	1100	185	<b>1812473</b>	<b>DADP-ES-G6-20</b>
DADP-ES-G6-25	80	20	10	6.8	2.6	1100	160	<b>1812550</b>	<b>DADP-ES-G6-25</b>

Ordering data					
	For size	Description	Part No.	Type	PU <sup>1)</sup>
Centring sleeve ZBH <span style="float: right;">Technical data → Internet: zbh</span>					
	12, 16	For centring the shock absorber retainer (2 pieces included in the scope of delivery of the shock absorber retainer)	<b>186717</b>	<b>ZBH-7</b>	10
Connector sleeve ZBV <span style="float: right;">Technical data → Internet: zbv</span>					
	20, 25	For centring the shock absorber retainer (2 pieces included in the scope of delivery of the shock absorber retainer)	<b>548806</b>	<b>ZBV-12-9</b>	10





1) Packaging unit

- Note

- A shock absorber retainer DADP-ES is additionally required when using an intermediate position module
- Operation without cushioning components is not permitted
- Cushioning components are not included in the scope of delivery
- The shock absorbers for mini slides and for the associated shock absorber retainer are of identical size. Shock absorber selection → 7
- The same cushioning component as is used in the end positions of the mini slide is used for cushioning the intermediate position

# Intermediate-position module DADM-EP

Accessories

Ordering data							
	For size	For shock absorber retainer	Description	Order code	Part No.	Type	PU <sup>1)</sup>
Shock absorber DYEF-...-Y1							Technical data → Internet: dyef
	DGSL-12	DADP-ES-G6-12	Flexible cushioning, without metal stop	P	1179837	DYEF-M10-Y1	1
	DGSL-16	DADP-ES-G6-16			1179840	DYEF-M12-Y1	
	DGSL-20	DADP-ES-G6-20			1179863	DYEF-M14-Y1	
	DGSL-25	DADP-ES-G6-25			1179879	DYEF-M16-Y1	
Shock absorber DYEF-S-...-Y1							Technical data → Internet: dyef
	DGSL-12	DADP-ES-G6-12	Flexible cushioning, without metal stop, short version	E	1152959	DYEF-S-M10-Y1	1
	DGSL-16	DADP-ES-G6-16			1153004	DYEF-S-M12-Y1	
	DGSL-20	DADP-ES-G6-20			1153017	DYEF-S-M14-Y1	
	DGSL-25	DADP-ES-G6-25			1153023	DYEF-S-M16-Y1	
Shock absorber DYEF-...-Y1F							Technical data → Internet: dyef
	DGSL-12	DADP-ES-G6-12	Flexible cushioning, with metal stop	P1	548374	DYEF-M10-Y1F	1
	DGSL-16	DADP-ES-G6-16			548375	DYEF-M12-Y1F	
	DGSL-20	DADP-ES-G6-20			548376	DYEF-M14-Y1F	
	DGSL-25	DADP-ES-G6-25			548377	DYEF-M16-Y1F	
Shock absorber DYSW							Technical data → Internet: dysw
	DGSL-12	DADP-ES-G6-12	Progressive shock absorbers, both ends	Y3	548072	DYSW-7-10-Y1F	1
	DGSL-16	DADP-ES-G6-16			548073	DYSW-8-14-Y1F	
	DGSL-20	DADP-ES-G6-20			548074	DYSW-10-17-Y1F	
	DGSL-25	DADP-ES-G6-25			548075	DYSW-12-20-Y1F	
Reducing sleeve DAYH							
	DGSL-12	DADP-ES-G6-12	For DYSW-5-8	-	1165480	DAYH-5	1
	DGSL-16	DADP-ES-G6-16	For DYSW-7-10		1165484	DAYH-7	
	DGSL-20	DADP-ES-G6-20	For DYSW-8-14		1165488	DAYH-8	
	DGSL-25	DADP-ES-G6-25	For DYSW-10-17		1165491	DAYH-10	

1) Packaging unit quantity

# Intermediate-position module DADM-EP

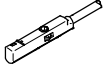

Accessories

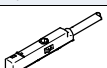
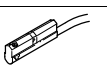
Proximity sensors for DADM-EP-G6-10						
Ordering data – Proximity sensors for C-slot, magneto-resistive						Technical data → Internet: smt
	Type of mounting	Switching output	Electrical connection, outlet direction	Cable length [m]	Part No.	Type
N/O contact						
	Inserted in the slot from above	PNP	Cable, 3-wire, in-line	2.5	551373	SMT-10M-PS-24V-E-2,5-L-OE
			Plug connector M8x1, 3-pin, in-line	0.3	551375	SMT-10M-PS-24V-E-0,3-L-M8D
			Plug connector M8x1, 3-pin, lateral	0.3	551376	SMT-10M-PS-24V-E-0,3-Q-M8D

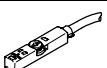
Ordering data – Proximity sensor for C-slot, magnetic reed						
Ordering data – Proximity sensor for C-slot, magnetic reed						Technical data → Internet: sme
	Type of mounting	Switching output	Electrical connection, outlet direction	Cable length [m]	Part No.	Type
N/O contact						
	Inserted in the slot from above	Contacting	Plug connector M8x1, 3-pin, in-line	0.3	551367	SME-10M-DS-24V-E-0,3-L-M8D
			Cable, 3-wire, in-line	2.5	551365	SME-10M-DS-24V-E-2,5-L-OE
			Cable, 2-wire, in-line	2.5	551369	SME-10M-ZS-24V-E-2,5-L-OE
	Insertable into the slot lengthwise	Contacting	Plug connector M8x1, 3-pin, in-line	0.3	173212	SME-10-SL-LED-24
			Cable, 3-wire, in-line	2.5	173210	SME-10-KL-LED-24

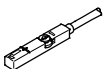
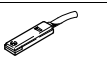
Proximity sensors for DADM-EP-G6-16						
Ordering data – Proximity sensor for T-slot, magneto-resistive						Technical data → Internet: smt
	Type of mounting	Switching output	Electrical connection	Cable length [m]	Part No.	Type
N/O contact						
	Inserted in the slot from above, flush with the cylinder profile, short design	PNP	Cable, 3-wire	2.5	574335	SMT-8M-A-PS-24V-E-2,5-OE
			Plug connector M8x1, 3-pin	0.3	574334	SMT-8M-A-PS-24V-E-0,3-M8D
			Plug connector M12x1, 3-pin	0.3	574337	SMT-8M-A-PS-24V-E-0,3-M12
		NPN	Cable, 3-wire	2.5	574338	SMT-8M-A-NS-24V-E-2,5-OE
			Plug connector M8x1, 3-pin	0.3	574339	SMT-8M-A-NS-24V-E-0,3-M8D

Ordering data – Proximity sensors for T-slot, magnetic reed						
Ordering data – Proximity sensors for T-slot, magnetic reed						Technical data → Internet: sme
	Type of mounting	Switching output	Electrical connection	Cable length [m]	Part No.	Type
N/O contact						
	Inserted in the slot from above, flush with the cylinder profile	Contacting	Cable, 3-wire	2.5	543862	SME-8M-DS-24V-K-2,5-OE
			Cable, 3-wire	5.0	543863	SME-8M-DS-24V-K-5,0-OE
			Cable, 2-wire	2.5	543872	SME-8M-ZS-24V-K-2,5-OE
			Plug connector M8x1, 3-pin	0.3	543861	SME-8M-DS-24V-K-0,3-M8D
	Inserted in the slot lengthwise, flush with the cylinder profile	Contacting	Cable, 3-wire	2.5	150855	SME-8-K-LED-24
			Plug connector M8x1, 3-pin	0.3	150857	SME-8-S-LED-24

Ordering data – Connecting cables						
Ordering data – Connecting cables						Technical data → Internet: nebu
	Electrical connection, left	Electrical connection, right	Cable length [m]	Part No.	Type	
	Straight socket, M8x1, 3-pin	Cable, open end, 3-wire	2.5	541333	NEBU-M8G3-K-2.5-LE3	
			5	541334	NEBU-M8G3-K-5-LE3	
	Angled socket, M8x1, 3-pin	Cable, open end, 3-wire	2.5	541338	NEBU-M8W3-K-2.5-LE3	
			5	541341	NEBU-M8W3-K-5-LE3	



## Product Range and Company Overview

### A Complete Suite and Company Overview

Our experienced engineers provide complete support at every stage of your development process, including: conceptualization, analysis, engineering, design, assembly, documentation, validation, and production.



**Custom Automation Components**  
Complete custom engineered solutions



**Custom Control Cabinets**  
Comprehensive engineering support and on-site services



**Complete Systems**  
Shipment, stocking and storage services

### The Broadest Range of Automation Components

With a comprehensive line of more than 30,000 automation components, Festo is capable of solving the most complex automation requirements.



**Electromechanical**  
Electromechanical actuators, motors, controllers & drivers



**Pneumatics**  
Pneumatic linear and rotary actuators, valves, and air supply



**PLCs and I/O Devices**  
PLC's, operator interfaces, sensors and I/O devices

### Supporting Advanced Automation... As No One Else Can!

Festo is a leading global manufacturer of pneumatic and electromechanical systems, components and controls for industrial automation, with more than 16,000 employees in 60 national headquarters serving more than 180 countries. For more than 80 years, Festo has continuously elevated the state of manufacturing with innovations and optimized motion control solutions that deliver higher performing, more profitable automated manufacturing and processing equipment. Our dedication to the advancement of automation extends beyond technology to the education and development of current and future automation and robotics designers with simulation tools, teaching programs, and on-site services.

### Quality Assurance, ISO 9001 and ISO 14001 Certifications

Festo Corporation is committed to supply all Festo products and services that will meet or exceed our customers' requirements in product quality, delivery, customer service and satisfaction.

To meet this commitment, we strive to ensure a consistent, integrated, and systematic approach to management that will meet or exceed the requirements of the ISO 9001 standard for Quality Management and the ISO 14001 standard for Environmental Management.



© Copyright 2013, Festo Corporation. While every effort is made to ensure that all dimensions and specifications are correct, Festo cannot guarantee that publications are completely free of any error, in particular typing or printing errors. Accordingly, Festo cannot be held responsible for the same. For Liability and Warranty conditions, refer to our "Terms and Conditions of Sale", available from your local Festo office. All rights reserved. No part of this publication may be reproduced, distributed, or transmitted in any form or by any means, electronic, mechanical, photocopying or otherwise, without the prior written permission of Festo. All technical data subject to change according to technical update.



Printed on recycled paper at New Horizon Graphic, Inc., FSC certified as an environmental friendly printing plant.

# Festo North America

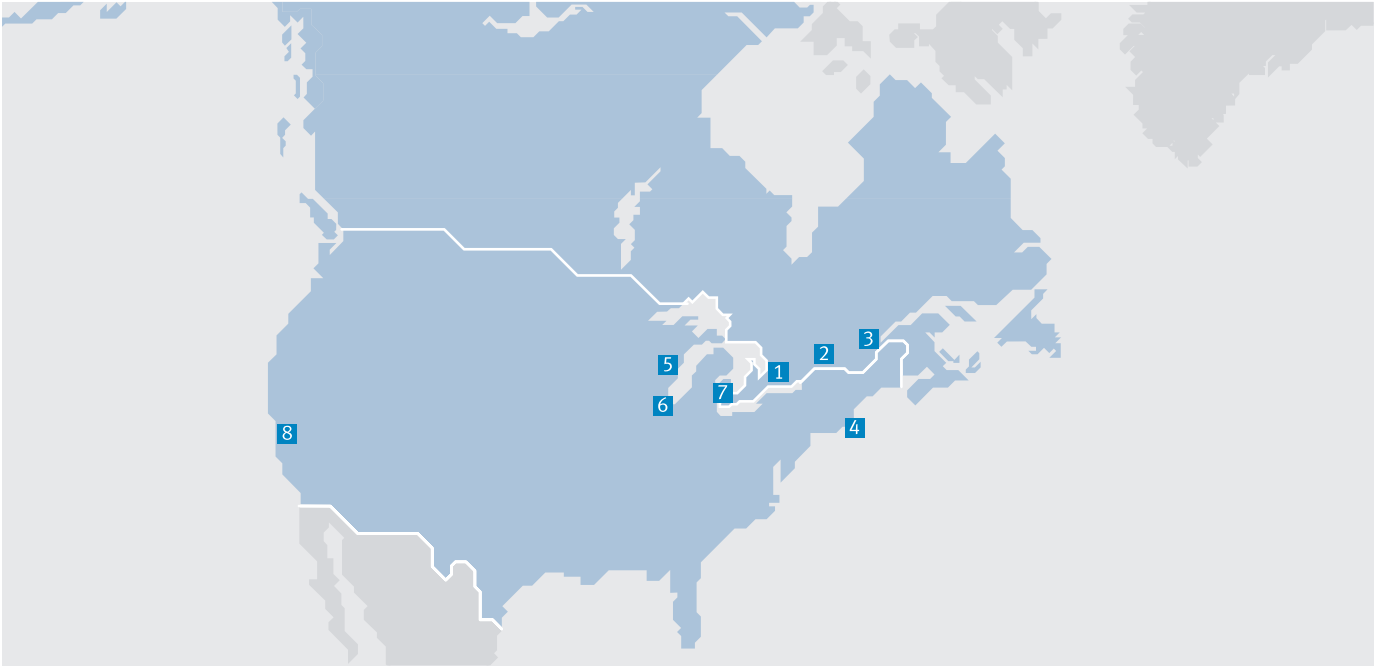

**1 Festo Canada  
Headquarters  
Festo Inc.**  
5300 Explorer Drive  
Mississauga, ON  
L4W 5G4

**2 Montréal**  
5600, Trans-Canada  
Pointe-Claire, QC  
H9R 1B6

**3 Québec City**  
2930, rue Watt#117  
Québec, QC  
G1X 4G3



**4 Festo United States  
Headquarters  
Festo Corporation**  
395 Moreland Road  
Hauppauge, NY  
11788

**5 Appleton**  
North 922 Tower View Drive, Suite N  
Greenville, WI  
54942

**7 Detroit**  
1441 West Long Lake Road  
Troy, MI  
48098

**6 Chicago**  
85 W Algonquin - Suite 340  
Arlington Heights, IL  
60005

**8 Silicon Valley**  
4935 Southfront Road, Suite F  
Livermore, CA  
94550

## Festo Regional Contact Center

### Canadian Customers

Commercial Support:  
Tel: 1 877 GO FESTO (1 877 463 3786)  
Fax: 1 877 FX FESTO (1 877 393 3786)  
Email: festo.canada@ca.festo.com

### Technical Support:

Tel: 1 866 GO FESTO (1 866 463 3786)  
Fax: 1 877 FX FESTO (1 877 393 3786)  
Email: technical.support@ca.festo.com

### USA Customers

Commercial Support:  
Tel: 1 800 99 FESTO (1 800 993 3786)  
Fax: 1 800 96 FESTO (1 800 963 3786)  
Email: customer.service@us.festo.com

### Technical Support:

Tel: 1 866 GO FESTO (1 866 463 3786)  
Fax: 1 800 96 FESTO (1 800 963 3786)  
Email: product.support@us.festo.com