

Controllers CECC



Controllers CECC

Key features



Application Controller



The controllers CECC are modern, compact and versatile controllers that enable programming with CODESYS according to IEC 61131-3.

State-of-the-art programming

CODESYS V3 pbF offers a user-friendly interface with the following new functions:

- Object-oriented programming
- Modern editors for simplified input
- Simplified configuration for fieldbus

- New configurator for IO-Link masters
- **IO-Link**
- Multiple controllers in one project
- Improved troubleshooting function
- Simplified project navigation

Basic functions of the CECC-D

The controllers CECC (CECC-D) offer the following basic functions:

- 12 digital inputs, 8 digital outputs, additionally 2 high-speed counters up to 250 kHz
- Ethernet 10/100 Mbps, Modbus TCP client/server, EasyIP, TCP/IP, OPC Server available

- CANopen master: connection of the electric drives
- USB interface for data transfer
- Can be connected directly with modern HMI devices: CDPX

Additional functions of the CECC-LK

- This variant of the CECC offers four IO-Link masters and one IO-Link device interface
- The integrated IO-Link interface of the CECC-LK enables quick and easy connection of Festo valve terminals and sensors to a controller

- All modern, compact valve terminals from the CTEU series can be connected to IO-Link masters: VTUB, VTUG, MPA, CPV, VTOC and upcoming devices, as well as the input box CTSL

Additional functions CECC-S

- 2 RS232 interfaces
- 1 RS422/RS485 interface, allows freely configurable communication with different devices
- The RS422 interface can optionally be used as an encoder interface. For this operating mode, there are numerous setting options on the encoder type, comparison functions and referencing

- In addition, the CECC offers an IO-Link master and an IO-Link device interface

Fieldbus interfaces

The CECC-LK and CECC-S can be connected to a combination of CTEU nodes and CAPC on various fieldbuses via the IO-Link device interface:

- PROFIBUS
- EtherCAT
- DeviceNet
- CANopen
- AS-interface



System configuration (example) CECC with CANopen

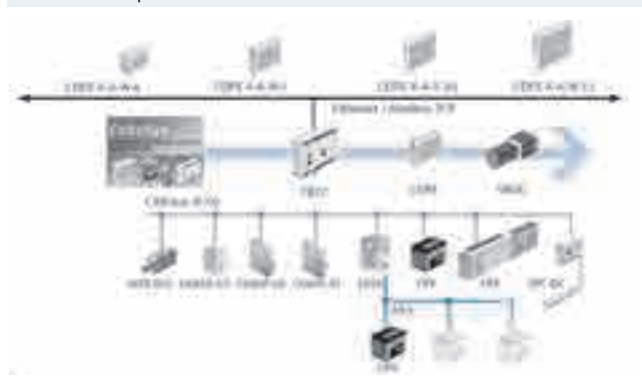

The CECC can communicate with all electric drive controllers from Festo and actuate all valve terminals via CANopen.

The CECC communicates with other controllers and operator units from Festo, such as the modern, new HMI device series CDPX and the camera SBOx-Q for image evaluation, via Ethernet.

Controllers CECC

Peripherals overview

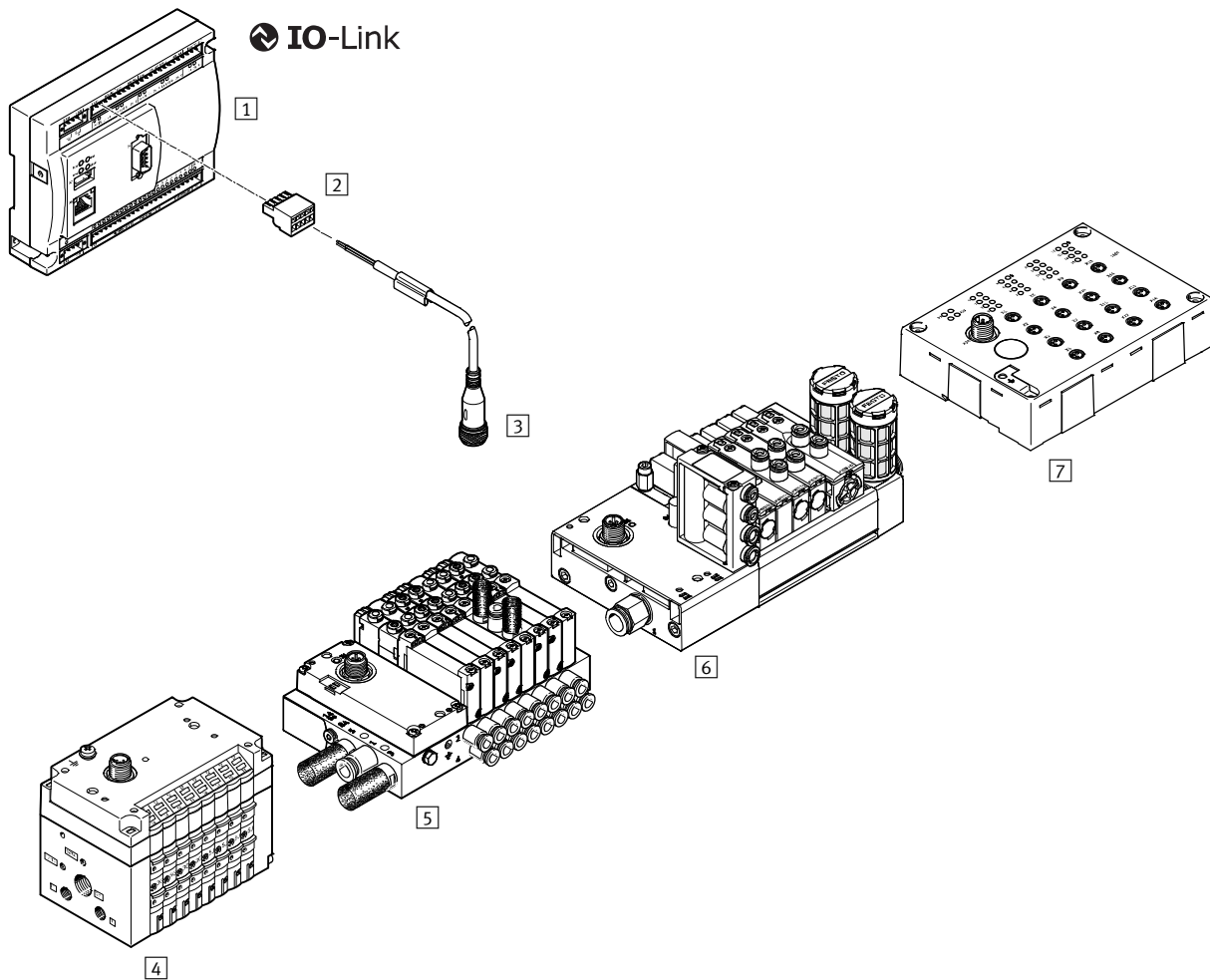



Mounting attachments and accessories			
	Brief description	→ Page/Internet	
1	Controller CECC	The integrated IO-Link interface of the CECC enables quick and easy connection of Festo valve terminals and sensors to a controller	4
2	Plug NECC	Plug connector for self-assembly with 2, 5, 6, 8 or 24 pins	9
3	Connecting cable NEBU	–	10
4	Valve terminal CPV	–	cpv
5	Valve terminal VTUG	–	vtug
6	Valve terminal VTUB	–	vtub
7	Input module CTSL	–	cteu
–	Software CODESYS V3	The software CODESYS V3 with the order code GSPF-CD-3 enables standardised programming according to IEC 61131-3 using object-oriented additional functions	10

Controllers CECC

Technical data

FESTO

-  Voltage
19.2 ... 30 V DC
-  Temperature range
0 ... +50 °C



General technical data			
Type	CECC-LK	CECC-D	CECC-S
CPU data	400 MHz processor		
Status displays	LED		
Electrical connection technology for I/O	Socket strip, grid 3.5 mm		
Resistance to vibration	As per EN 61131-2		
Resistance to shock	As per EN 61131-2		
Relative air humidity [%]	95, non-condensing		
Protection class	IP20		
Electrical protection class	III		
Product weight [g]	200		
Note on materials	RoHS-compliant		

Operating and environmental conditions			
	CECC-LK	CECC-D	CECC-S
Operating voltage [V DC]	19.2 ... 30		20.4 ... 30
Current consumption at 24 V DC [mA]	100		
Ambient temperature [°C]	0 ... 55		
Storage temperature [°C]	-25 ... +70		
CE marking	To EU EMC Directive		
Approval	RCM trademark		

Encoder inputs			
Type	CECC-LK	CECC-D	CECC-S
Number	-	-	1
Resolution [bit]	-	-	32
Signal range [V]	-	-	5, differential (RS 422)
Max. input frequency [kHz]	-	-	1000
Encoder supply voltage	-	-	5 V DC (100 mA)

Controllers CECC

Technical data

FESTO

Digital inputs		CECC-LK	CECC-D	CECC-S
Number		12		
Switching logic		Positive logic (PNP)		
Fast clock pulse inputs		2, each with max. 200 kHz		
Input signal delay		Typically 3 ms		
Input voltage	[V DC]	24		
Nominal value for TRUE	[V DC]	≥ 15		
Nominal value for FALSE	[V DC]	≤ 5		
Electrical isolation		Yes, via optocoupler		
Status display		LED		
Permissible connecting cable length	[m]	30		

Digital outputs		CECC-LK	CECC-D	CECC-S
Number		8		
Switching logic		Positive logic (PNP)		
Contact		Transistor		
Output voltage	[V DC]	24		
Output current	[mA]	500		
Electrical isolation		Yes, via optocoupler		
Status display		LED		
Switching frequency	[kHz]	Max. 1		
Protection against short circuit		Yes		

Serial interfaces		CECC-LK	CECC-D	CECC-S
USB interface		USB 1.1		
Fieldbus interface type		CAN bus		
Number		–	–	3
Type		–	–	2x RS 232 / 1x RS 485-A/422-A
Connection technology		–	–	Plug
Baud rate	[bit/s]	–	–	300 ... 375,000
Fieldbus interface				
Connection technology		Sub-D plug, 9-pin		
Transmission rate	[kbps]	125; 250; 500; 800; 1,000 Adjustable via software		
Galvanic isolation		Yes		

Ethernet		CECC-LK	CECC-D	CECC-S
Number		1		
Connector plug		RJ45		
Supported protocols		TCP/IP, EasyIP, Modbus TCP		
Transmission speed	[Mbps]	10/100		
Protocol		CANopen		
		IO-Link	–	IO-Link
		I-Port	–	I-Port
		Modbus TCP		

Controllers CECC

Technical data

Programming			
	CECC-LK	CECC-D	CECC-S
Programming software	CODESYS provided by Festo		
Programming language according to IEC 61131-3	SFC		
	IL		
	FCH		
	LDR		
	ST		

IO-Link			
	CECC-LK	CECC-D	CECC-S
Number of ports	Master 4	–	Master 1
	Device 1	–	Device 1
Port class	Device A	–	Device A
	Master B	–	Master B
Protocol	Device V 1.0	–	Device V 1.0
	Master V 1.1	–	Master V 1.1
Connection technology	Plug	–	Plug
	Cage clamp	–	Cage clamp
	Device, 3-pin	–	Device, 3-pin
	Master, 5-pin	–	Master, 5-pin
Communication mode	Configurable via software	–	Configurable via software
	Device COM1 (4.8 kB), COM2 (38.4 kB), COM3 (230 kB)	–	Device COM1 (4.8 kB), COM2 (38.4 kB), COM3 (230 kB)
	Master SIO, COM1 (4.8 kB), COM2 (38.4 kB), COM3 (230 kB)	–	Master SIO, COM1 (4.8 kB), COM2 (38.4 kB), COM3 (230 kB)
Master, output current [A]	3.5/port	–	3.5/port
Communication	C/Q green LED	–	C/Q green LED
	C/Q red LED	–	C/Q red LED
Ready status display	L+ green LED on	–	L+ green LED on
	L+ green LED off	–	L+ green LED off
Process data width OUT	Master parameterisable 2 - 32 bytes	–	Master parameterisable 2 - 32 bytes
Process data width IN	Master parameterisable 2 - 32 bytes	–	Master parameterisable 2 - 32 bytes
Memory card	2 kB per port	–	2 kB per port
Minimum cycle time	Device 3.2 ms	–	Device 3.2 ms
	Master 5 ms	–	Master 5 ms

Controllers CECC

Technical data



Dimensions

Download CAD data → www.festo.com

CECC-LK

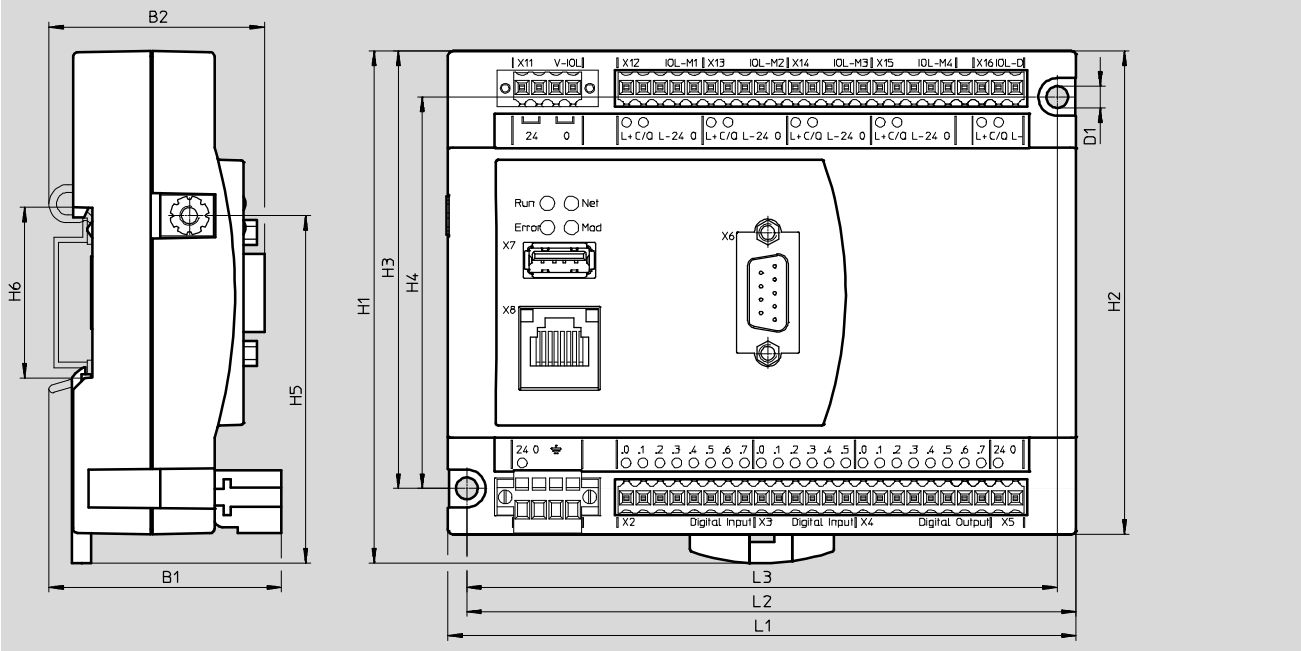

CECC-D

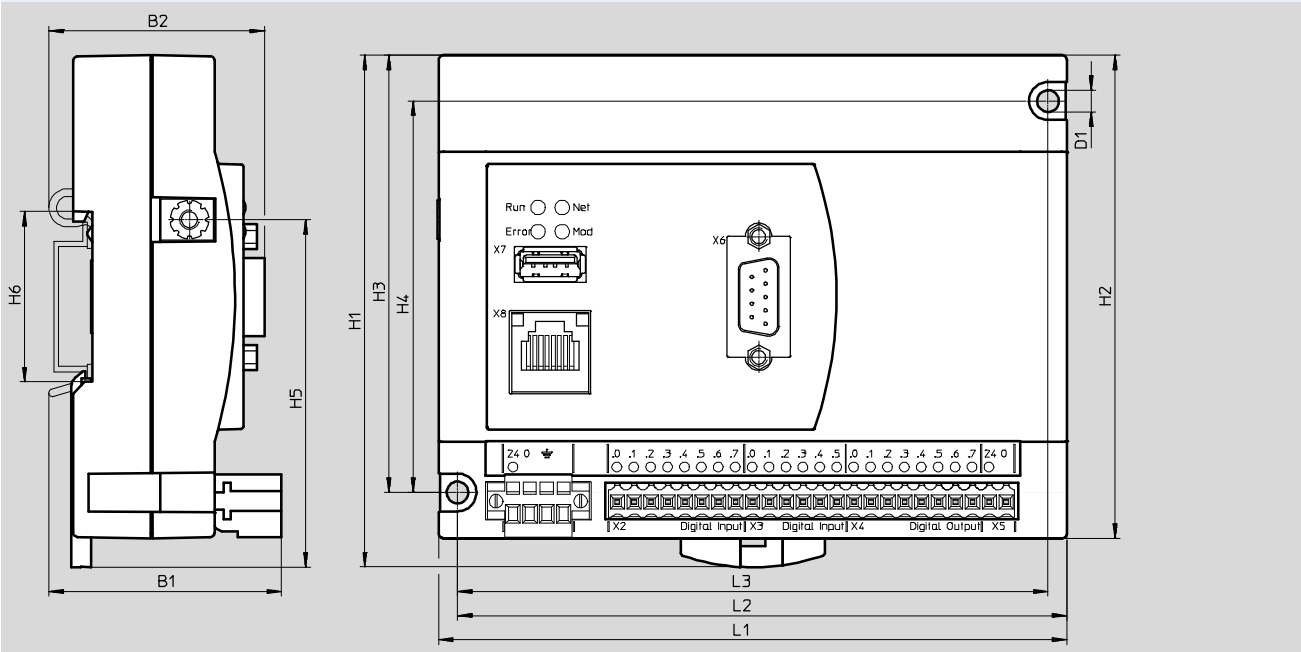

Type	B1	B2	D1	H1	H2	H3	H4	H5	H6	L1	L2	L3
CECC-LK	48.15	44.6	4.5	106	100	90.5	81	72	35.2	130	126.11	122.2
CECC-D	48.15	44.6	4.5	106	100	90.5	81	72	35.2	130	126.11	122.2

Controllers CECC

Technical data

FESTO

Dimensions

Download CAD data → www.festo.com

CECC-S

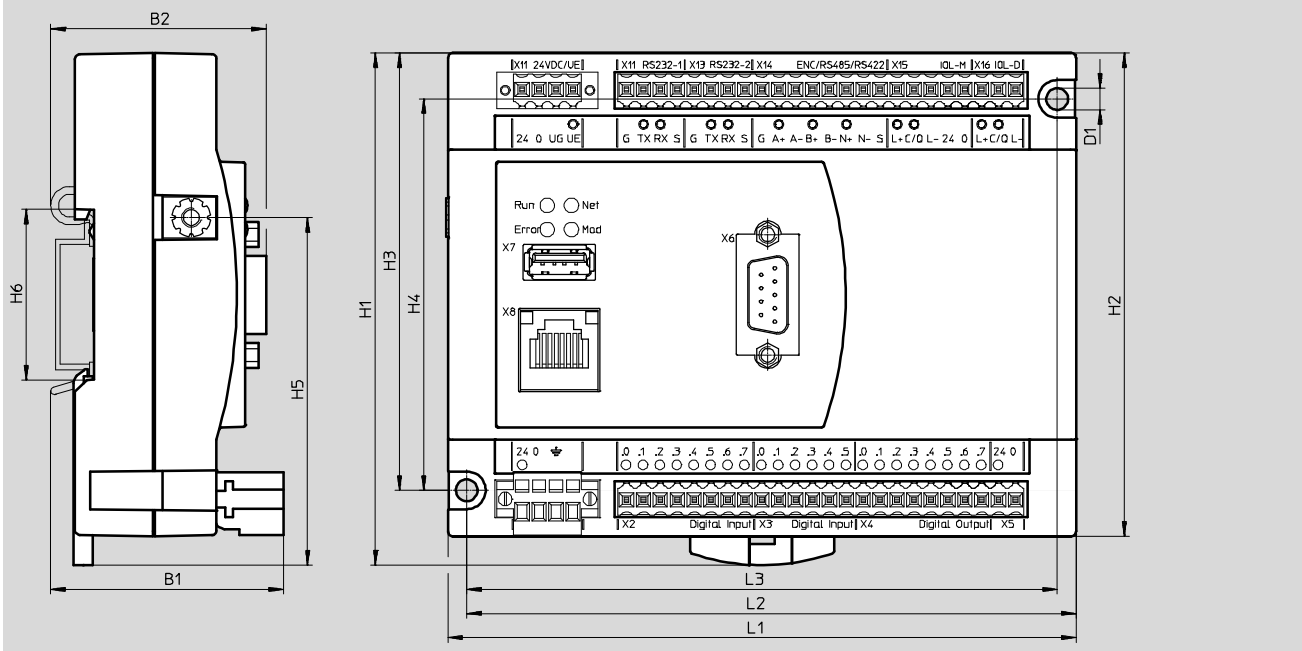

Type	B1	B2	D1 Ø	H1	H2	H3	H4	H5	H6	L1	L2	L3
CECC-S	47.2	43.6	4.5	106	100	90.5	81	72	35.2	130	126.1	122.2

Ordering data

Controllers	Brief description	Part No.	Type
CECC-LK	With 14 digital inputs and 8 digital outputs, Ethernet, USB, CANopen, 4 IO-Link masters, 1 IO-Link device	574418	CECC-LK
CECC-D	With 14 digital inputs and 8 digital outputs, Ethernet, USB, CANopen	574415	CECC-D
CECC-S	With 14 digital inputs and 8 digital outputs, Ethernet, USB, CANopen, 2 RS232, 1 RS485/RS422/Encoder, 1 IO-Link masters, 1 IO-Link device	574416	CECC-S

Controllers CECC

Accessories

FESTO

Dimensions

Download CAD data → www.festo.com

Plug

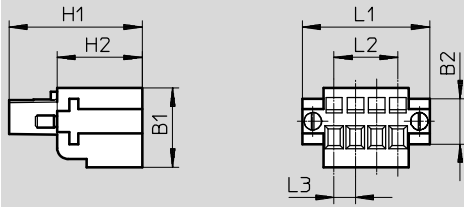

Type	B1	B2	H1	H2	L1	L2	L3
NECC-L2G4-C1-M	13	7.5	21.9	14	21	10.5	3.5

Dimensions

Download CAD data → www.festo.com

Plug

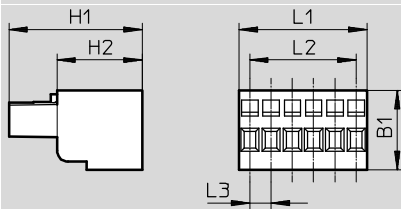

Type	B1	H1	H2	L1	L2	L3
NECC-L2G2-C1	13	21.9	14	7	3.5	3.5
NECC-L2G5-C1				17.5	14	
NECC-L2G6-C1				21	17.5	
NECC-L2G8-C1				28	24.5	
NECC-L2G24-C1				84	80.5	

Materials

Corrosion resistance class CRC ¹⁾	1
Note on materials	RoHS-compliant

1) Corrosion resistance class CRC 1 to Festo standard FN 940070

Low corrosion stress. For dry indoor applications or transport and storage protection. Also applies to parts behind covers, in the non-visible interior area, and parts which are covered in the application (e.g. drive trunnions).

Dimensions

Download CAD data → www.festo.com

Plug

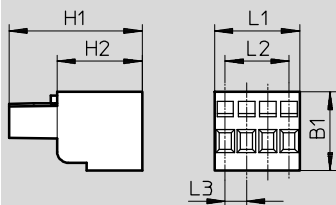



Type	B1	H1	H2	L1	L2	L3
NECC-L2G4-C1	13	21.9	14	14	10.5	3.5



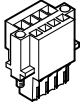
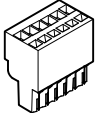

Controllers CECC

Accessories

FESTO

Ordering data				
	Description	PU ²⁾	Part No.	Type
Plug				
	Plug connector for self-assembly	1	575303	NECC-L2G4-C1-M
	Plug connector for self-assembly, 2-pin	1	575302	NECC-L2G2-C1
	Plug connector for self-assembly, 4-pin	1	8024782	NECC-L2G4-C1
	Plug connector for self-assembly, 5-pin	1	575304	NECC-L2G5-C1
	Plug connector for self-assembly, 6-pin	1	575305	NECC-L2G6-C1
	Plug connector for self-assembly, 8-pin	1	575306	NECC-L2G8-C1
	Plug connector for self-assembly, 24-pin	1	575307	NECC-L2G24-C1
	Sub-D plug, 9-pin with screw terminal, protection class IP40	1	576031	NECC-S1G9-C2-M

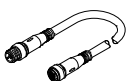
2) Packaging unit

Ordering data				
	Description	Part No.	Type	
Connecting cables				
	Straight socket, 5-pin, M12 – open cable end Cable length 2.5 m	541330	NEBU-M12G5-K-2.5-LE5	
	Angled socket, 5-pin, M12 – open cable end Cable length 2.5 m	567843	NEBU-M12W5-K-2.5-LE5	
	Up to 20 m long ¹⁾	574321	NEBU-M12G5-E-5-Q8-M12G5	
		574322	NEBU-M12G5-E-7.5-Q8-M12G5	
		574323	NEBU-M12G5-E-10-Q8-M12G5	
Programming software				
	This software is optimised for configuring, programming, commissioning and maintaining automation solutions	542000	GSPF-CDS-3	

1) Modular product, more information → Internet:nebu

Product Range and Company Overview

A Complete Suite and Company Overview

Our experienced engineers provide complete support at every stage of your development process, including: conceptualization, analysis, engineering, design, assembly, documentation, validation, and production.



Custom Automation Components
Complete custom engineered solutions



Custom Control Cabinets
Comprehensive engineering support and on-site services



Complete Systems
Shipment, stocking and storage services

The Broadest Range of Automation Components

With a comprehensive line of more than 30,000 automation components, Festo is capable of solving the most complex automation requirements.



Electromechanical
Electromechanical actuators, motors, controllers & drivers



Pneumatics
Pneumatic linear and rotary actuators, valves, and air supply



PLCs and I/O Devices
PLC's, operator interfaces, sensors and I/O devices

Supporting Advanced Automation... As No One Else Can!

Festo is a leading global manufacturer of pneumatic and electromechanical systems, components and controls for industrial automation, with more than 16,000 employees in 60 national headquarters serving more than 180 countries. For more than 80 years, Festo has continuously elevated the state of manufacturing with innovations and optimized motion control solutions that deliver higher performing, more profitable automated manufacturing and processing equipment. Our dedication to the advancement of automation extends beyond technology to the education and development of current and future automation and robotics designers with simulation tools, teaching programs, and on-site services.

Quality Assurance, ISO 9001 and ISO 14001 Certifications

Festo Corporation is committed to supply all Festo products and services that will meet or exceed our customers' requirements in product quality, delivery, customer service and satisfaction.

To meet this commitment, we strive to ensure a consistent, integrated, and systematic approach to management that will meet or exceed the requirements of the ISO 9001 standard for Quality Management and the ISO 14001 standard for Environmental Management.



© Copyright 2013, Festo Corporation. While every effort is made to ensure that all dimensions and specifications are correct, Festo cannot guarantee that publications are completely free of any error, in particular typing or printing errors. Accordingly, Festo cannot be held responsible for the same. For Liability and Warranty conditions, refer to our "Terms and Conditions of Sale", available from your local Festo office. All rights reserved. No part of this publication may be reproduced, distributed, or transmitted in any form or by any means, electronic, mechanical, photocopying or otherwise, without the prior written permission of Festo. All technical data subject to change according to technical update.



Printed on recycled paper at New Horizon Graphic, Inc., FSC certified as an environmental friendly printing plant.

Festo North America

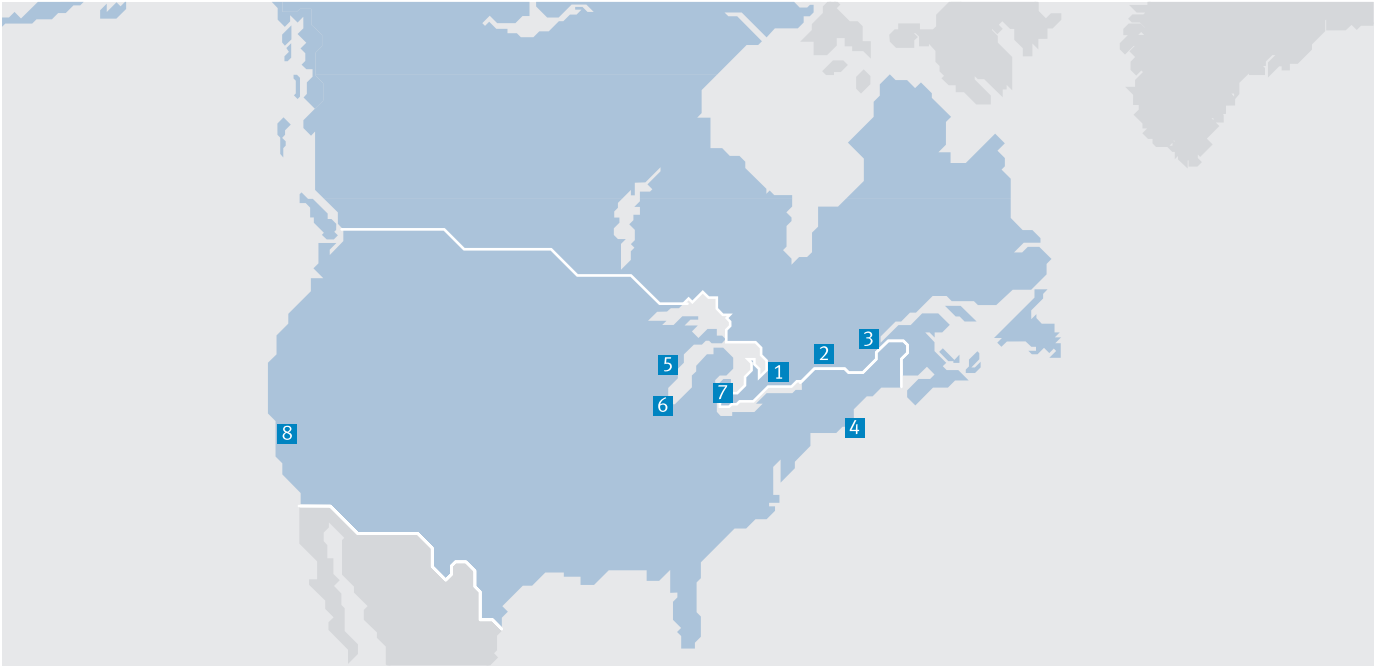

**1 Festo Canada
Headquarters
Festo Inc.**
5300 Explorer Drive
Mississauga, ON
L4W 5G4

2 Montréal
5600, Trans-Canada
Pointe-Claire, QC
H9R 1B6

3 Québec City
2930, rue Watt#117
Québec, QC
G1X 4G3



**4 Festo United States
Headquarters
Festo Corporation**
395 Moreland Road
Hauppauge, NY
11788

5 Appleton
North 922 Tower View Drive, Suite N
Greenville, WI
54942

7 Detroit
1441 West Long Lake Road
Troy, MI
48098

6 Chicago
85 W Algonquin - Suite 340
Arlington Heights, IL
60005

8 Silicon Valley
4935 Southfront Road, Suite F
Livermore, CA
94550

Festo Regional Contact Center

Canadian Customers

Commercial Support:
Tel: 1 877 GO FESTO (1 877 463 3786)
Fax: 1 877 FX FESTO (1 877 393 3786)
Email: festo.canada@ca.festo.com

Technical Support:

Tel: 1 866 GO FESTO (1 866 463 3786)
Fax: 1 877 FX FESTO (1 877 393 3786)
Email: technical.support@ca.festo.com

USA Customers

Commercial Support:
Tel: 1 800 99 FESTO (1 800 993 3786)
Fax: 1 800 96 FESTO (1 800 963 3786)
Email: customer.service@us.festo.com

Technical Support:

Tel: 1 866 GO FESTO (1 866 463 3786)
Fax: 1 800 96 FESTO (1 800 963 3786)
Email: product.support@us.festo.com