



- Piston rod secured against rotation by means of guide rods and yoke plate
- Profile slots for proximity sensors
- Extensive range of accessories

Compact cylinders ADVUL

Peripherals overview

FESTO

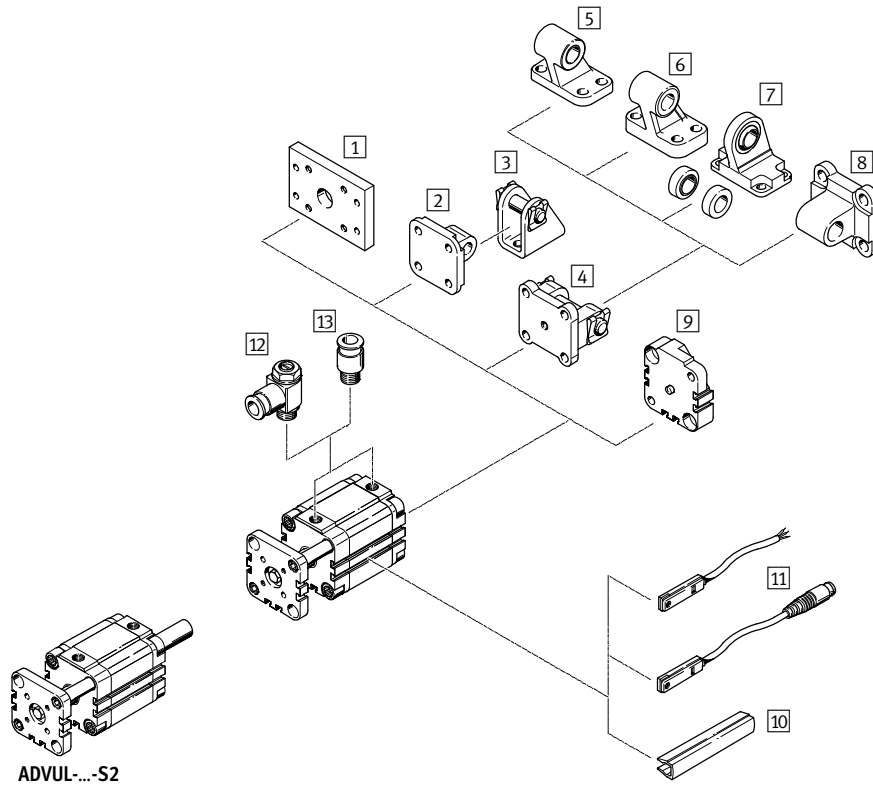

ADVUL...-S2

Mounting attachments and accessories					
	Brief description	ADVUL		→ Page/Internet	
			S2		
1	Flange mounting FUA	For end caps	■	■	11
2	Swivel flange SUA for Ø 12 ... 25	For end caps	■	-	12
3	Clevis foot LBN	-	■	-	14
4	Swivel flange SUA for Ø 32 ... 100	For end caps	■	-	12
5	Clevis foot LN	-	■	-	14
6	Clevis foot LNG	-	■	-	14
7	Clevis foot LSN	With spherical bearing	■	-	14
8	Swivel flange SNCL	-	■	-	14
9	Adapter kit DPVU	For connecting two cylinders with identical piston diameter to form a multi-position cylinder	■	-	13
10	Slot cover ABP-5-S	To protect the sensor cable and keep dirt out of the sensor slots	■	■	15
11	Proximity sensor SME/SMT-8	Can be integrated in the cylinder profile barrel	■	■	15
12	One-way flow control valve GRLA	To regulate speed	■	■	14
13	Push-in fitting QS	For connecting compressed air tubing with standard external diameters	■	■	quick star

Compact cylinders ADVUL

Type codes

ADVUL - 50 - 80 - P - A - S2

Type

Double-acting

ADVUL Compact cylinder, secured against rotation by means of guide rods and yoke plate

Piston Ø [mm]

Stroke [mm]

Cushioning

P Flexible cushioning rings/plates at both ends

Position sensing

A For proximity sensing

Variant

S2 Through piston rod

S6 Heat-resistant seals up to 120 °C

Compact cylinders ADVUL

Technical data

FESTO

Function

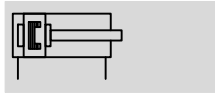

- Ø - Diameter
12 ... 100 mm

- | - Stroke length
1 ... 400 mm

-  - www.festo.com

Wearing parts kits, see
→ 10

Variants



S2



S6



ADVUL-...-...-P-A



ADVUL-...-...-P-A-S2

General technical data										
Piston Ø	12	16	20	25	32	40	50	63	80	100
Pneumatic connection	M5	M5	M5	M5	G1/8	G1/8	G1/8	G1/8	G1/8	G1/4
Operating medium	Compressed air in accordance with ISO 8573-1:2010 [7:4:4]									
Note on operating/pilot medium	Operation with lubricated medium possible (in which case lubricated operation will always be required)									
Constructional design	Piston									
	Piston rod									
	Cylinder barrel									
Cushioning	Flexible cushioning rings/plates at both ends									
Position sensing	For proximity sensing									
Type of mounting	Via through-holes									
	With female thread									
	Via accessories									
Mounting position	Any									

Operating pressure [bar]										
Piston Ø	12	16	20	25	32	40	50	63	80	100
Piston rod at one end	1.5 ... 10			1.0 ... 10						
Through piston rod S2	1.5 ... 10				1.0 ... 10					

Ambient conditions		
Compact cylinder	Basic version	S6
Ambient temperature ¹⁾ [°C]	-20 ... +80	0 ... +120
Corrosion resistance class CRC ²⁾	2	2

1) Note operating range of proximity sensors

2) Corrosion resistance class CRC 2 to Festo standard FN 940070

Moderate corrosion stress. Indoor applications in which condensation may occur. External visible parts with primarily decorative requirements for the surface and which are in direct contact with the ambient atmosphere typical for industrial applications.

Compact cylinders ADVUL

Technical data

FESTO

Forces [N] and impact energy [J]										
Piston \varnothing	12	16	20	25	32	40	50	63	80	100
Theoretical force at 6 bar, advancing	68	121	188	295	483	754	1178	1870	3016	4712
S2	51	90	141	247	415	686	1057	1750	2827	4418
Theoretical force at 6 bar, retracting	51	90	141	247	415	686	1057	1750	2827	4418
S2	51	90	141	247	415	686	1057	1750	2827	4418
Max. impact energy at end positions	0.09	0.10	0.14	0.10	0.40	0.52	0.64	0.70	0.75	1.00

Max. lateral force F_q as a function of projection x

Piston rod at one end

Through piston rod

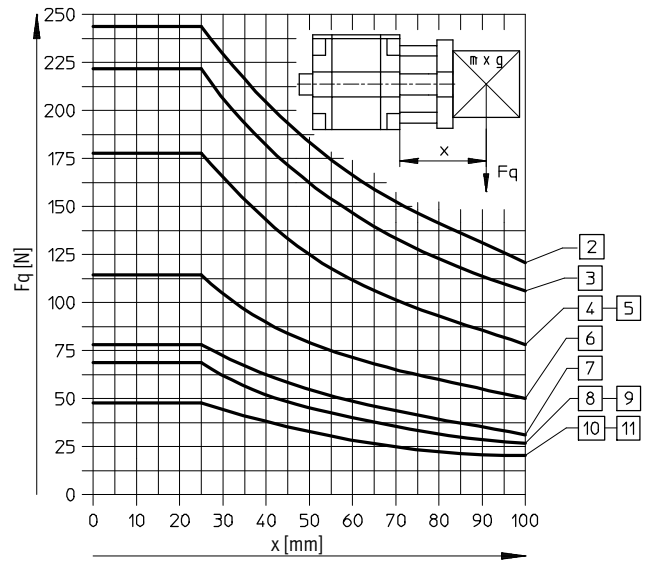
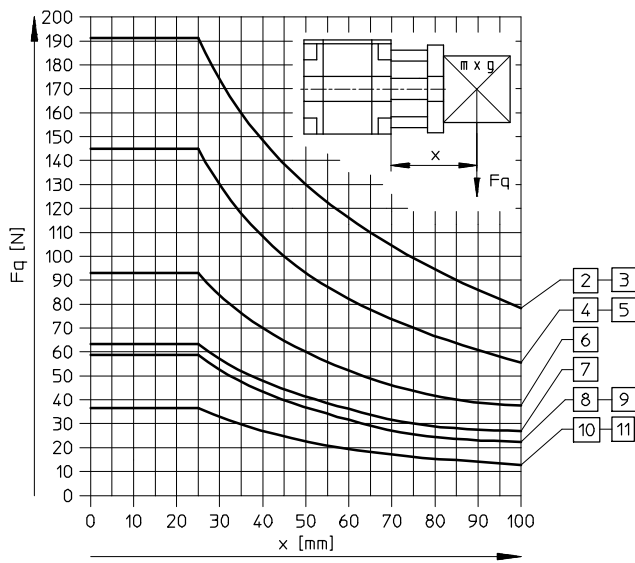

- 2 \varnothing 100 mm
- 3 \varnothing 80 mm
- 4 \varnothing 63 mm

- 5 \varnothing 50 mm
- 6 \varnothing 40 mm
- 7 \varnothing 32 mm

- 8 \varnothing 25 mm
- 9 \varnothing 20 mm
- 10 \varnothing 16 mm

- 11 \varnothing 12 mm

Torque M in relation to stroke length L

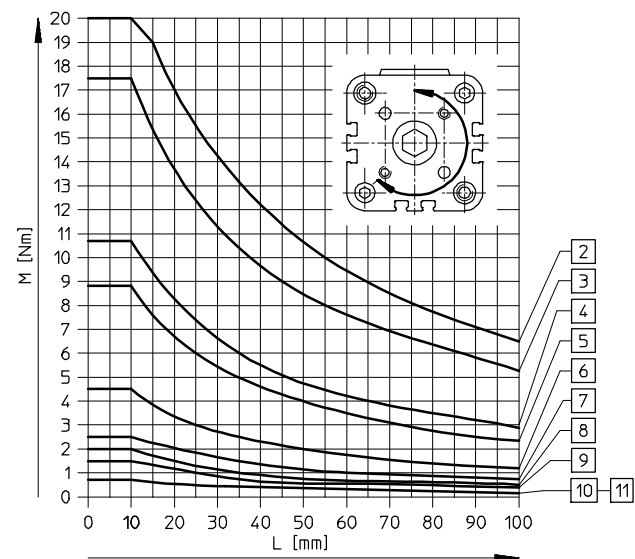

- 2 \varnothing 100 mm
- 3 \varnothing 80 mm
- 4 \varnothing 63 mm
- 5 \varnothing 50 mm
- 6 \varnothing 40 mm

- 7 \varnothing 32 mm
- 8 \varnothing 25 mm
- 9 \varnothing 20 mm
- 10 \varnothing 16 mm
- 11 \varnothing 12 mm

Compact cylinders ADVUL

Technical data

FESTO

Materials

Sectional view

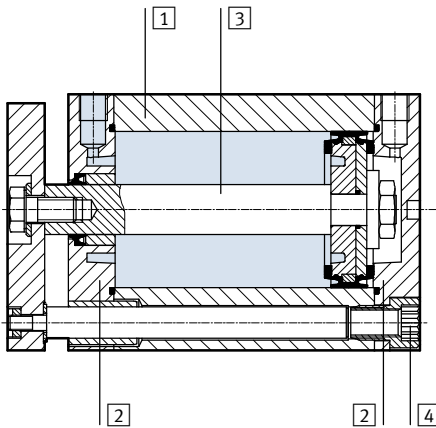

Compact cylinder	Basic version	S6
1 Cylinder barrel	Wrought aluminium alloy	Wrought aluminium alloy
2 Bearing and end cap	Wrought aluminium alloy	Wrought aluminium alloy
3 Piston rod	∅ 12 ... 32	High-alloy stainless steel
	∅ 40 ... 100	High-alloy steel
4 Flange screws	∅ 12 ... 16	High-alloy stainless steel
	∅ 20 ... 100	Tempered steel
- Seals	Polyurethane, nitrile rubber	Fluorocautchouc

Weights [g]										
Piston ∅	12	16	20	25	32	40	50	63	80	100
Product weight with 0mm stroke	100	103	179	215	362	517	707	1252	2150	3316
Additional weight per 10 mm stroke	14	16	26	28	38	45	64	72	97	116
Moving load with 0 mm stroke	21	26	50	61	111	147	259	327	685	1133
Additional load per 10 mm stroke	4	6	11	11	17	17	29	29	43	43

Compact cylinders ADVUL

Technical data

FESTO

Dimensions – Basic cylinders

Download CAD data → www.festo.com

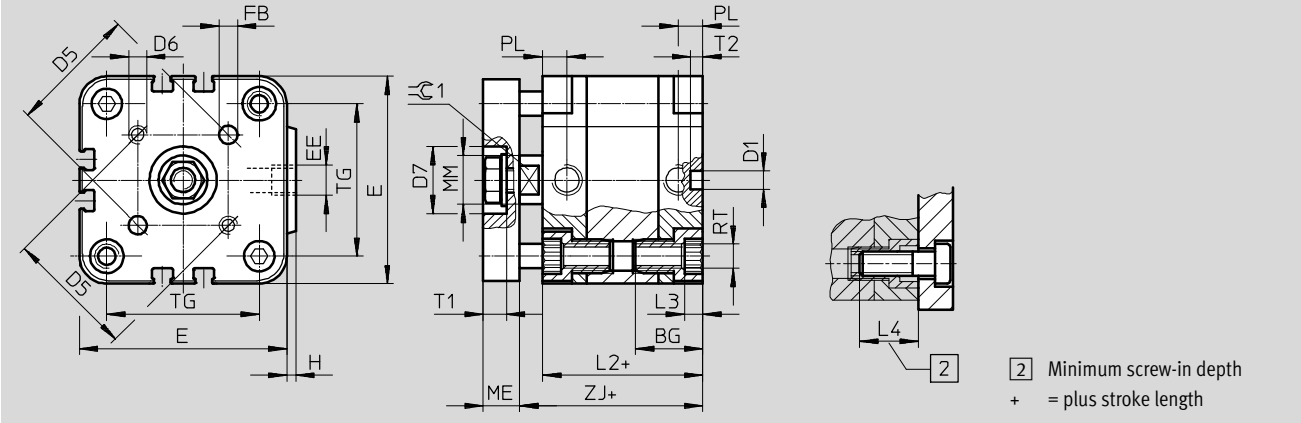

∅ [mm]	BG ¹⁾	D1 ∅ H9	D5	D6	D7 ∅ H9	E	EE	FB ∅ H8	H	L2
12	18.5	6	14	M3	–	29	M5	3	1	38
16	18.5	6	14	M3	–	29	M5	3	1	38
20	18.5	6	17	M4	–	36	M5	4	1.5	38
25	18.5	6	22	M5	14	40	M5	5	1.5	39.5
32	21.5	6	28	M5	17	50	G $\frac{1}{8}$	5	2	44.5
40	21.5	6	33	M5	17	60	G $\frac{1}{8}$	5	2.5	45.5
50	22	6	42	M6	22	68	G $\frac{1}{8}$	6	3	45.5
63	24.5	8	50	M6	22	87	G $\frac{1}{8}$	6	4	50
80	27.5	8	65	M8	28	107	G $\frac{1}{8}$	8	4	56
100	32.5	8	80	M10	30	128	G $\frac{1}{4}$	10	5	66.5

∅ [mm]	L3	L4	ME	MM ∅	PL	RT	T1 +0.2	T2 –0.2	TG	≈C1 h13
12	3	16	6	6	8	M4	–	4	18	5
16	3	16	6	8	8	M4	–	4	18	7
20	4	18	8	10	8	M5	–	4	22	9
25	4	18	8	10	8	M5	4.8	4	26	9
32	5	20	10	12	8	M6	6.1	4	32	10
40	5	20	10	12	8	M6	6.1	4	42	10
50	6	20	12	16	8	M8	7.6	4	50	13
63	8	25	12	16	8	M10	7.6	4	62	13
80	8	25	14	20	8.5	M10	8.7	4	82	17
100	8	25	14	25	10.5	M10	10.3	4	103	22

1) Do not exceed screw-in depth

Compact cylinders ADVUL

Technical data

FESTO

Dimensions – Variants

Download CAD data → www.festo.com

Piston rod at one end

Through piston rod

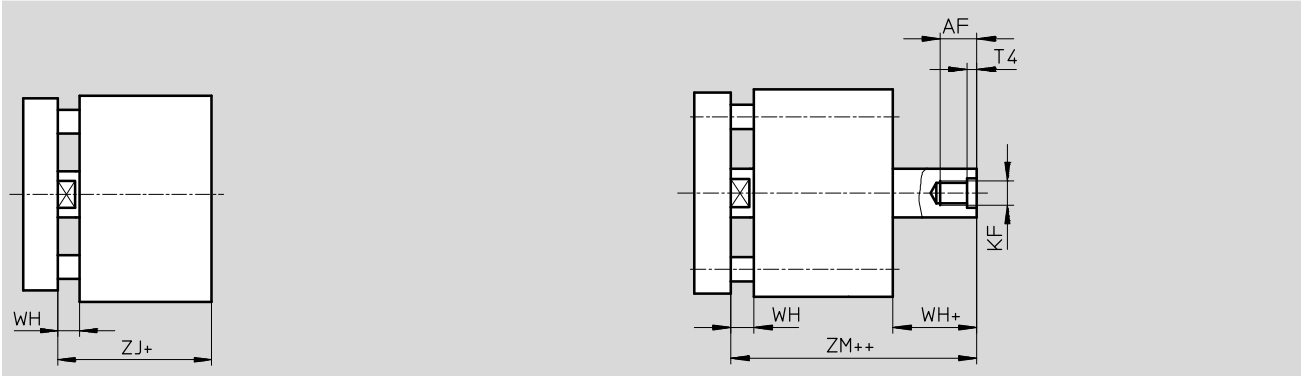

∅	AF	KF	T4	WH	ZJ	ZM
[mm]						
12	8	M3	1.5	4.5	42.5	47
16	10	M4	1.5	4.5	42.5	47
20	12	M5	2	4.5	42.5	47
25	12	M5	2	5.5	45	50.5
32	14	M6	2.6	6	50.5	56.5
40	14	M6	2.6	6.5	52	58.5
50	16	M8	3.3	7.5	53	60.5
63	16	M8	3.3	7.5	57.5	65
80	20 ¹⁾	M10	4.7	8	64	72
100	24 ¹⁾	M12	6.1	10	76.5	86.5

1) With a stroke < 5 mm, the maximum screw-in depth is reduced by 5 mm

Compact cylinders ADVUL

Technical data



FESTO

Ordering data – Basic version						
Type	Stroke [mm]	Part No.	Type	Stroke [mm]	Part No.	Type
	Piston Ø 12 mm			Piston Ø 16 mm		
	5	156844	ADVUL-12-5-P-A	5	156851	ADVUL-16-5-P-A
	10	156845	ADVUL-12-10-P-A	10	156852	ADVUL-16-10-P-A
	15	156846	ADVUL-12-15-P-A	15	156853	ADVUL-16-15-P-A
	20	156847	ADVUL-12-20-P-A	20	156854	ADVUL-16-20-P-A
	25	156848	ADVUL-12-25-P-A	25	156855	ADVUL-16-25-P-A
	30	156849	ADVUL-12-30-P-A	30	156856	ADVUL-16-30-P-A
	40	156850	ADVUL-12-40-P-A	40	156857	ADVUL-16-40-P-A
	Piston Ø 20 mm			Piston Ø 25 mm		
	5	156858	ADVUL-20-5-P-A	5	156866	ADVUL-25-5-P-A
10	156859	ADVUL-20-10-P-A	10	156867	ADVUL-25-10-P-A	
15	156860	ADVUL-20-15-P-A	15	156868	ADVUL-25-15-P-A	
20	156861	ADVUL-20-20-P-A	20	156869	ADVUL-25-20-P-A	
25	156862	ADVUL-20-25-P-A	25	156870	ADVUL-25-25-P-A	
30	156863	ADVUL-20-30-P-A	30	156871	ADVUL-25-30-P-A	
40	156864	ADVUL-20-40-P-A	40	156872	ADVUL-25-40-P-A	
50	156865	ADVUL-20-50-P-A	50	156873	ADVUL-25-50-P-A	
Piston Ø 32 mm			Piston Ø 40 mm			
5	156874	ADVUL-32-5-P-A	5	156884	ADVUL-40-5-P-A	
10	156875	ADVUL-32-10-P-A	10	156885	ADVUL-40-10-P-A	
15	156876	ADVUL-32-15-P-A	15	156886	ADVUL-40-15-P-A	
20	156877	ADVUL-32-20-P-A	20	156887	ADVUL-40-20-P-A	
25	156878	ADVUL-32-25-P-A	25	156888	ADVUL-40-25-P-A	
30	156879	ADVUL-32-30-P-A	30	156889	ADVUL-40-30-P-A	
40	156880	ADVUL-32-40-P-A	40	156890	ADVUL-40-40-P-A	
50	156881	ADVUL-32-50-P-A	50	156891	ADVUL-40-50-P-A	
60	156882	ADVUL-32-60-P-A	60	156892	ADVUL-40-60-P-A	
80	156883	ADVUL-32-80-P-A	80	156893	ADVUL-40-80-P-A	
Piston Ø 50 mm			Piston Ø 63 mm			
10	156894	ADVUL-50-10-P-A	10	156903	ADVUL-63-10-P-A	
15	156895	ADVUL-50-15-P-A	15	156904	ADVUL-63-15-P-A	
20	156896	ADVUL-50-20-P-A	20	156905	ADVUL-63-20-P-A	
25	156897	ADVUL-50-25-P-A	25	156906	ADVUL-63-25-P-A	
30	156898	ADVUL-50-30-P-A	30	156907	ADVUL-63-30-P-A	
40	156899	ADVUL-50-40-P-A	40	156908	ADVUL-63-40-P-A	
50	156900	ADVUL-50-50-P-A	50	156909	ADVUL-63-50-P-A	
60	156901	ADVUL-50-60-P-A	60	156910	ADVUL-63-60-P-A	
80	156902	ADVUL-50-80-P-A	80	156911	ADVUL-63-80-P-A	
Piston Ø 80 mm			Piston Ø 100 mm			
10	156912	ADVUL-80-10-P-A	10	156921	ADVUL-100-10-P-A	
15	156913	ADVUL-80-15-P-A	15	156922	ADVUL-100-15-P-A	
20	156914	ADVUL-80-20-P-A	20	156923	ADVUL-100-20-P-A	
25	156915	ADVUL-80-25-P-A	25	156924	ADVUL-100-25-P-A	
30	156916	ADVUL-80-30-P-A	30	156925	ADVUL-100-30-P-A	
40	156917	ADVUL-80-40-P-A	40	156926	ADVUL-100-40-P-A	
50	156918	ADVUL-80-50-P-A	50	156927	ADVUL-100-50-P-A	
60	156919	ADVUL-80-60-P-A	60	156928	ADVUL-100-60-P-A	
80	156920	ADVUL-80-80-P-A	80	156929	ADVUL-100-80-P-A	

Compact cylinders ADVUL

Technical data

FESTO

Ordering data – Variants				
Type	Piston Ø [mm]	Stroke [mm]	Part No.	Type
Variable stroke				
	12	1 ... 200	156200	ADVUL-12-...-P-A
	16	1 ... 200	156201	ADVUL-16-...-P-A
	20	1 ... 200	156202	ADVUL-20-...-P-A
	25	1 ... 200	156203	ADVUL-25-...-P-A
	32	1 ... 300	156204	ADVUL-32-...-P-A
	40	1 ... 300	156205	ADVUL-40-...-P-A
	50	1 ... 300	156206	ADVUL-50-...-P-A
	63	1 ... 300	156207	ADVUL-63-...-P-A
	80	1 ... 400	156208	ADVUL-80-...-P-A
	100	1 ... 400	156209	ADVUL-100-...-P-A
S2 – Through piston rod, variable stroke				
	12	1 ... 200	165089	ADVUL-12-...-P-A-S2
	16	1 ... 200	165090	ADVUL-16-...-P-A-S2
	20	1 ... 200	165091	ADVUL-20-...-P-A-S2
	25	1 ... 200	165092	ADVUL-25-...-P-A-S2
	32	1 ... 300	165093	ADVUL-32-...-P-A-S2
	40	1 ... 300	165094	ADVUL-40-...-P-A-S2
	50	1 ... 300	165095	ADVUL-50-...-P-A-S2
	63	1 ... 300	165096	ADVUL-63-...-P-A-S2
	80	1 ... 400	165097	ADVUL-80-...-P-A-S2
	100	1 ... 400	165098	ADVUL-100-...-P-A-S2

Ordering data – Variants				
Type	Piston Ø [mm]	Stroke [mm]	Part No.	Type
S6 – Heat-resistant up to 120 °C, variable stroke				
	12	1 ... 200	156210	ADVUL-12-...-P-A-S6
	16	1 ... 200	156211	ADVUL-16-...-P-A-S6
	20	1 ... 200	156212	ADVUL-20-...-P-A-S6
	25	1 ... 200	156213	ADVUL-25-...-P-A-S6
	32	1 ... 300	156214	ADVUL-32-...-P-A-S6
	40	1 ... 300	156215	ADVUL-40-...-P-A-S6
	50	1 ... 300	156216	ADVUL-50-...-P-A-S6
	63	1 ... 300	156217	ADVUL-63-...-P-A-S6
	80	1 ... 400	156218	ADVUL-80-...-P-A-S6
	100	1 ... 400	156219	ADVUL-100-...-P-A-S6

Ordering data – Wearing parts kits				
	Part No.	Type	Part No.	Type
Piston Ø	Basic version		S6 – Heat-resistant up to 120 °C	
12	121115	ADVUL-12-...-P-A ¹⁾	383559	ADVUL-12-...-P-A-S6 ²⁾
16	121116	ADVUL-16-...-P-A ¹⁾	383560	ADVUL-16-...-P-A-S6 ²⁾
20	121117	ADVUL-20-...-P-A ¹⁾	383561	ADVUL-20-...-P-A-S6 ²⁾
25	121118	ADVUL-25-...-P-A ¹⁾	383562	ADVUL-25-...-P-A-S6 ²⁾
32	121119	ADVUL-32-...-P-A ¹⁾	383563	ADVUL-32-...-P-A-S6 ¹⁾
40	121120	ADVUL-40-...-P-A ¹⁾	383564	ADVUL-40-...-P-A-S6 ¹⁾
50	121121	ADVUL-50-...-P-A ¹⁾	383565	ADVUL-50-...-P-A-S6 ¹⁾
63	121122	ADVUL-63-...-P-A ¹⁾	383566	ADVUL-63-...-P-A-S6 ¹⁾
80	121123	ADVUL-80-...-P-A ¹⁾	383567	ADVUL-80-...-P-A-S6 ¹⁾
100	121124	ADVUL-100-...-P-A ¹⁾	383568	ADVUL-100-...-P-A-S6 ¹⁾

1) Assembly grease included in scope of delivery

2) Assembly grease not included in scope of delivery. If required, please order separately under part no. 329 555 (20 ml)

Compact cylinders ADVUL

Accessories

Flange mounting FUA

Material:
Clear anodised aluminium

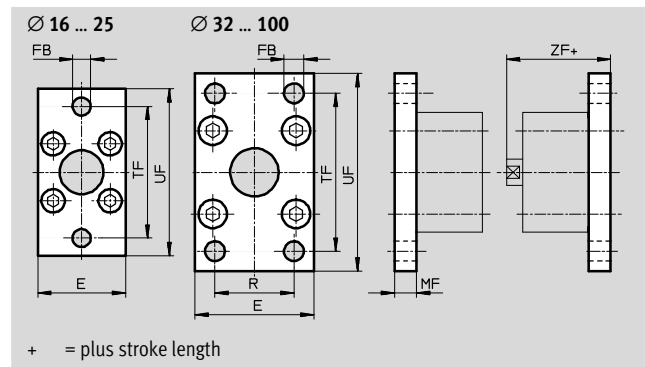

Dimensions and ordering data											
For Ø	E	FB	MF	R	TF	UF	ZF	CRC ¹⁾	Weight	Part No.	Type
[mm]		Ø							[g]		
12/16	29	5.5	10	–	43	55	52.5	2	48	157299	FUA-12/16
20	36	6.6	10	–	55	70	52.5	2	77	157300	FUA-20
25	40	6.6	10	–	60	76	55	2	91	157301	FUA-25
32	50	7	10	32	65	80	60.5	2	290	157302	FUA-32
40	60	9	10	36	82	102	62	2	449	157303	FUA-40
50	68	9	12	45	90	110	65	2	658	157304	FUA-50
63	87	9	15	50	110	130	72.5	2	1277	157305	FUA-63
80	107	12	15	63	135	160	76	2	1910	157306	FUA-80
100	128	14	15	75	163	190	91.5	2	2716	157307	FUA-100

1) Corrosion resistance class CRC 2 to Festo standard FN 940070
Moderate corrosion stress. Indoor applications in which condensation may occur. External visible parts with primarily decorative requirements for the surface and which are in direct contact with the ambient atmosphere typical for industrial applications.

Compact cylinders ADVUL

Accessories



Swivel flange SUA for piston \varnothing 12 ... 25 mm

Material:
Anodised aluminium
Free of copper and PTFE

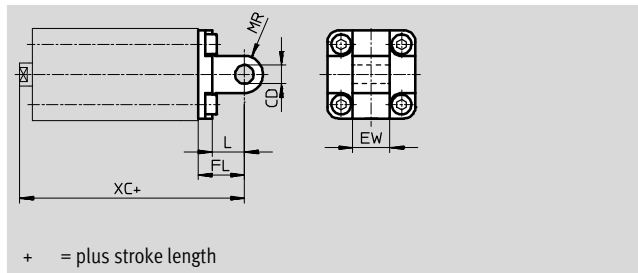

for piston \varnothing 32 ... 100 mm

Material:
Anodised aluminium
Free of copper and PTFE

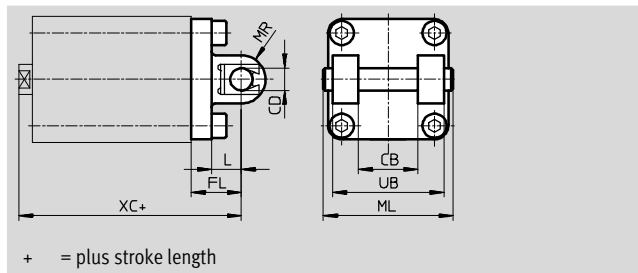

Dimensions and ordering data												
For \varnothing	CB	CD	EW	FL	L	ML	MR	UB	XC	Weight	Part No.	Type
[mm]		\varnothing								[g]		
12/16	-	6	12	16	10	-	6	-	58.5	22	157319	SUA-12/16
20	-	8	16	20	14	-	8	-	62.5	41	157320	SUA-20
25	-	8	16	20	14	-	8	-	64	45	157321	SUA-25
32	26	10	-	22	13	54	10	45	72.5	137	157322	SUA-32
40	28	12	-	25	16	62	12	52	77	199	157323	SUA-40
50	32	12	-	27	16	70	12	60	80	287	157324	SUA-50
63	40	16	-	32	21	82	16	70	89.5	530	157325	SUA-63
80	50	16	-	36	23	102	16	90	100	770	157326	SUA-80
100	60	20	-	41	26	126	20	110	117.5	1283	157327	SUA-100

- - Note
The maximum stroke length may not be exceeded when combining cylinders and swivel flanges.

For \varnothing	Max. stroke length [mm]
12	50
16	50
20	50
25	50
32	100

For \varnothing	Max. stroke length [mm]
40	100
50	100
63	100
80	150
100	150

Compact cylinders ADVUL

Accessories



Adapter kit DPVU

Material:
Wrought aluminium alloy
Free of copper and PTFE

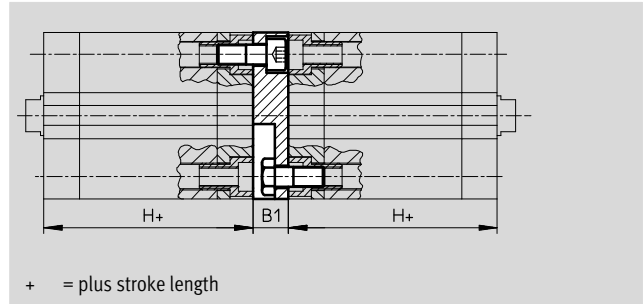

Dimensions and ordering data

For Ø [mm]	B1	H	Max. overall stroke length [mm]	CRC ¹⁾	Weight [g]	Part No.	Type
12/16	12.5	38	400	2	35	161194	DPVU-12/16
20	12.5	38			54	161195	DPVU-20
25	13	39.5			65	161196	DPVU-25
32	14.5	44.5	600		111	161197	DPVU-32
40	14.5	45.5			155	161198	DPVU-40
50	14.5	45.5			212	161199	DPVU-50
63	14.5	50	800		372	161200	DPVU-63
80	16.5	56			580	161201	DPVU-80
100	19.5	66.5			935	161202	DPVU-100

Note
The maximum overall stroke length may not be exceeded when combining cylinders and the multi-position adapter kit.

1) Corrosion resistance class CRC 2 to Festo standard FN 940070
Moderate corrosion stress. Indoor applications in which condensation may occur. External visible parts with primarily decorative requirements for the surface and which are in direct contact with the ambient atmosphere typical for industrial applications.

Connecting two cylinders with identical piston diameter as a 3 or 4-position cylinder

A 3 or 4-position cylinder consists of two separate cylinders whose piston rods advance in opposing directions.

Depending upon actuation and stroke pattern, this type of cylinder can assume up to four positions. In each

case the cylinder is driven precisely against a stop. If one end of the piston rod is fixed, the cylinder barrel

executes the movement. The cylinder must be connected with flexible line connections.

Implementing 3 positions

Two cylinders with identical stroke length must be connected to this end.

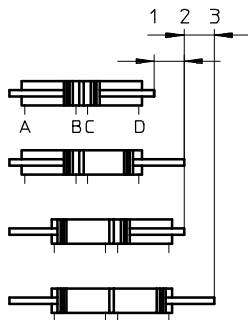

Implementing 4 positions

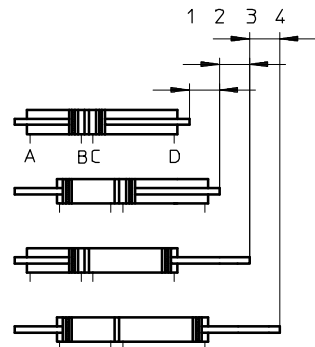

Two cylinders with different stroke lengths must be connected to this end.



Compact cylinders ADVUL

Accessories

FESTO

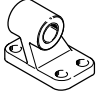
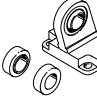
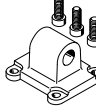
Ordering data – Mounting attachments				Technical data → Internet: mounting attachment			
Designation	For Ø	Part No.	Type	Designation	For Ø	Part No.	Type
Clevis foot LBN				Clevis foot LNG			
	12	6058	LBN-12/16		32	33890	LNG-32
	16	6058	LBN-12/16		40	33891	LNG-40
	20	6059	LBN-20/25		50	33892	LNG-50
	25	6059	LBN-20/25		63	33893	LNG-63
			80		33894	LNG-80	
			100		33895	LNG-100	
Clevis foot LN				Clevis foot LSN			
	32	5147	LN-32		32	5561	LSN-32
	40	5148	LN-40		40	5562	LSN-40
	50	5149	LN-50		50	5563	LSN-50
	63	5150	LN-63		63	5564	LSN-63
	80	5151	LN-80		80	5565	LSN-80
	100	5152	LN-100		100	5566	LSN-100
Swivel flange SNCL							
	32	174404	SNCL-32				
	40	174405	SNCL-40				
	50	174406	SNCL-50				
	63	174407	SNCL-63				
	80	174408	SNCL-80				
	100	174409	SNCL-100				



Ordering data – One-way flow control valves			Technical data → Internet: grla			
	Connection	For tubing O.D.	Material	Part No.	Type	
	Thread					
	M5	3	Metal design	193137	GRLA-M5-QS-3-D	
		4		193138	GRLA-M5-QS-4-D	
		6		193139	GRLA-M5-QS-6-D	
	G ¹ / ₈	3		193142	GRLA- ¹ / ₈ -QS-3-D	
		4		193143	GRLA- ¹ / ₈ -QS-4-D	
		6		193144	GRLA- ¹ / ₈ -QS-6-D	
	G ¹ / ₄	8		193145	GRLA- ¹ / ₈ -QS-8-D	
		6		193146	GRLA- ¹ / ₄ -QS-6-D	
		8		193147	GRLA- ¹ / ₄ -QS-8-D	
				10	193148	GRLA- ¹ / ₄ -QS-10-D

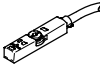
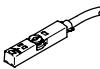

Compact cylinders ADVUL

Accessories

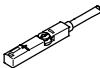
FESTO

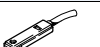
Ordering data – Proximity sensors for T-slot, magneto-resistive						Technical data → Internet: smt	
	Type of mounting	Switch output	Electrical connection	Cable length [m]	Part No.	Type	
N/O contact							
	Insertable in the slot from above, flush with cylinder profile, short design	PNP	Cable, 3-wire	2.5	574335	SMT-8M-A-PS-24V-E-2,5-OE	
			Plug M8x1, 3-pin	0.3	574334	SMT-8M-A-PS-24V-E-0,3-M8D	
			Plug M12x1, 3-pin	0.3	574337	SMT-8M-A-PS-24V-E-0,3-M12	
		NPN	Cable, 3-wire	2.5	574338	SMT-8M-A-NS-24V-E-2,5-OE	
			Plug M8x1, 3-pin	0.3	574339	SMT-8M-A-NS-24V-E-0,3-M8D	
N/C contact							
	Insertable in the slot from above, flush with cylinder profile, short design	PNP	Cable, 3-wire	7.5	574340	SMT-8M-A-PO-24V-E-7,5-OE	

Ordering data – Proximity sensors for T-slot, magnetic reed						Technical data → Internet: sme	
	Type of mounting	Switch output	Electrical connection	Cable length [m]	Part No.	Type	
N/O contact							
	Insertable in the slot from above, flush with cylinder profile	Contacting	Cable, 3-wire	2.5	543862	SME-8M-DS-24V-K-2,5-OE	
				5.0	543863	SME-8M-DS-24V-K-5,0-OE	
			Cable, 2-wire	2.5	543872	SME-8M-ZS-24V-K-2,5-OE	
				Plug M8x1, 3-pin	0.3	543861	SME-8M-DS-24V-K-0,3-M8D
	Insertable in the slot lengthwise, flush with the cylinder profile	Contacting	Cable, 3-wire	2.5	150855	SME-8-K-LED-24	
			Plug M8x1, 3-pin	0.3	150857	SME-8-S-LED-24	
N/C contact							
	Insertable in the slot lengthwise, flush with the cylinder profile	Contacting	Cable, 3-wire	7.5	160251	SME-8-0-K-LED-24	

Ordering data – Connecting cables					Technical data → Internet: nebu	
	Electrical connection, left	Electrical connection, right	Cable length [m]	Part No.	Type	
	Straight socket, M8x1, 3-pin	Cable, open end, 3-wire	2.5	541333	NEBU-M8G3-K-2.5-LE3	
			5	541334	NEBU-M8G3-K-5-LE3	
	Straight socket, M12x1, 5-pin	Cable, open end, 3-wire	2.5	541363	NEBU-M12G5-K-2.5-LE3	
			5	541364	NEBU-M12G5-K-5-LE3	
	Angled socket, M8x1, 3-pin	Cable, open end, 3-wire	2.5	541338	NEBU-M8W3-K-2.5-LE3	
			5	541341	NEBU-M8W3-K-5-LE3	
	Angled socket, M12x1, 5-pin	Cable, open end, 3-wire	2.5	541367	NEBU-M12W5-K-2.5-LE3	
			5	541370	NEBU-M12W5-K-5-LE3	

Ordering data – Slot cover for T-slot				
	Mounting	Length	Part No.	Type
	Insertable from above	2x 0.5 m	151680	ABP-5-S

Product Range and Company Overview

A Complete Suite and Company Overview

Our experienced engineers provide complete support at every stage of your development process, including: conceptualization, analysis, engineering, design, assembly, documentation, validation, and production.

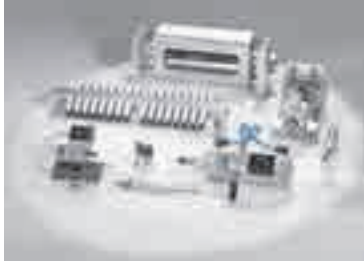

Custom Automation Components
Complete custom engineered solutions



Custom Control Cabinets
Comprehensive engineering support and on-site services

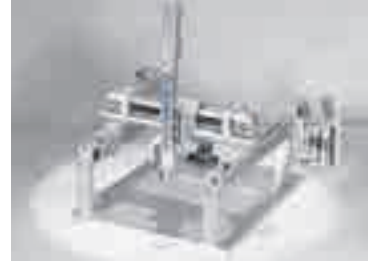

Complete Systems
Shipment, stocking and storage services

The Broadest Range of Automation Components

With a comprehensive line of more than 30,000 automation components, Festo is capable of solving the most complex automation requirements.



Electromechanical
Electromechanical actuators, motors, controllers & drivers



Pneumatics
Pneumatic linear and rotary actuators, valves, and air supply



PLCs and I/O Devices
PLC's, operator interfaces, sensors and I/O devices

Supporting Advanced Automation... As No One Else Can!

Festo is a leading global manufacturer of pneumatic and electromechanical systems, components and controls for industrial automation, with more than 16,000 employees in 60 national headquarters serving more than 180 countries. For more than 80 years, Festo has continuously elevated the state of manufacturing with innovations and optimized motion control solutions that deliver higher performing, more profitable automated manufacturing and processing equipment. Our dedication to the advancement of automation extends beyond technology to the education and development of current and future automation and robotics designers with simulation tools, teaching programs, and on-site services.

Quality Assurance, ISO 9001 and ISO 14001 Certifications

Festo Corporation is committed to supply all Festo products and services that will meet or exceed our customers' requirements in product quality, delivery, customer service and satisfaction.

To meet this commitment, we strive to ensure a consistent, integrated, and systematic approach to management that will meet or exceed the requirements of the ISO 9001 standard for Quality Management and the ISO 14001 standard for Environmental Management.



© Copyright 2013, Festo Corporation. While every effort is made to ensure that all dimensions and specifications are correct, Festo cannot guarantee that publications are completely free of any error, in particular typing or printing errors. Accordingly, Festo cannot be held responsible for the same. For Liability and Warranty conditions, refer to our "Terms and Conditions of Sale", available from your local Festo office. All rights reserved. No part of this publication may be reproduced, distributed, or transmitted in any form or by any means, electronic, mechanical, photocopying or otherwise, without the prior written permission of Festo. All technical data subject to change according to technical update.



Printed on recycled paper at New Horizon Graphic, Inc., FSC certified as an environmental friendly printing plant.

Festo North America



**1 Festo Canada
Headquarters
Festo Inc.**
5300 Explorer Drive
Mississauga, ON
L4W 5G4

2 Montréal
5600, Trans-Canada
Pointe-Claire, QC
H9R 1B6

3 Québec City
2930, rue Watt#117
Québec, QC
G1X 4G3



**4 Festo United States
Headquarters
Festo Corporation**
395 Moreland Road
Hauppauge, NY
11788

5 Appleton
North 922 Tower View Drive, Suite N
Greenville, WI
54942

7 Detroit
1441 West Long Lake Road
Troy, MI
48098

6 Chicago
85 W Algonquin - Suite 340
Arlington Heights, IL
60005

8 Silicon Valley
4935 Southfront Road, Suite F
Livermore, CA
94550

Festo Regional Contact Center

Canadian Customers

Commercial Support:
Tel: 1 877 GO FESTO (1 877 463 3786)
Fax: 1 877 FX FESTO (1 877 393 3786)
Email: festo.canada@ca.festo.com

Technical Support:
Tel: 1 866 GO FESTO (1 866 463 3786)
Fax: 1 877 FX FESTO (1 877 393 3786)
Email: technical.support@ca.festo.com

USA Customers

Commercial Support:
Tel: 1 800 99 FESTO (1 800 993 3786)
Fax: 1 800 96 FESTO (1 800 963 3786)
Email: customer.service@us.festo.com

Technical Support:
Tel: 1 866 GO FESTO (1 866 463 3786)
Fax: 1 800 96 FESTO (1 800 963 3786)
Email: product.support@us.festo.com