

Unidades de guía FEN/FENG para cilindros normalizados



Unidades de guía FEN/FENG para cilindros normalizados

Características

FESTO

Informaciones resumidas

Las guías FEN y FENG evitan que los cilindros normalizados giren si son expuestos a momentos elevados.

Además aumentan la precisión al manipular las piezas y en otras aplicaciones.

Dos variantes de guías:

- Guía de deslizamiento (GF)
- Guías con rodamiento de bolas (KF)

Combinaciones posibles actuador/unidad de guía

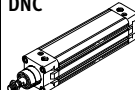
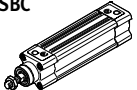
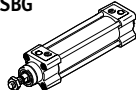
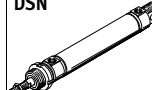
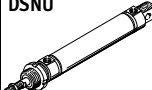
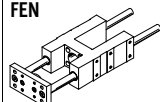
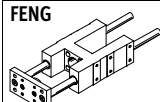
Actuador/ unidad de guía	DNC 	DSBC 	DSBG 	DSN 	DSNU 
FEN 	-	-	-	■	■
FENG 	■	■	■	-	-
→ Página / Internet	dnc	dsbc	dsbg	dsn	dsnu

Detección de posiciones

Cilindro normalizado DNC:
Estando montado, deberá utilizarse un conjunto de fijación para la consulta de la posición final delantera. La posición final posterior puede detectarse utilizando la ranura para detectores.

Cilindros normalizados DSNU:
En estos cilindros normalizados debe utilizarse obligatoriamente un conjunto de fijación para consultar las posiciones finales.



Kits de fijación			
Accionamiento	Diámetro del émbolo	Nº art.	Tipo
DSNU-...-A	8	175091	SMBR-8-8
	10	175092	SMBR-8-10
	12	175093	SMBR-8-12
	16	175094	SMBR-8-16
	20	175095	SMBR-8-20
	25	175096	SMBR-8-25
DNC-...-A	32, 40	175705	SMB-8-FENG-32/40
	50, 63	175706	SMB-8-FENG-50/63
	80, 100	175707	SMB-8-FENG-80/100

Unidades de guía FEN/FENG para cilindros normalizado

Código para el pedido

FENG	-	50	-	160	-	GF
------	---	----	---	-----	---	----

Tipo	
FEN	Unidad de guía según ISO 6432
FENG	Unidad de guía según ISO 15552

Diámetro del émbolo [mm]

Tamaño [mm]

Guía	
GF	Guía de deslizamiento
KF	Guía de rodamiento de bolas

Unidades de guía FEN/FENG para cilindros normalizados

FESTO

Hoja de datos

FEN según ISO 6432



- - Diámetro
8 ... 25 mm

- - Carrera
1 ... 250 mm



FENG según ISO 15552

- - Diámetro
32 ... 100 mm

- - Carrera
10 ... 500 mm



Datos técnicos generales										
Tipo	FEN-...				FENG-...					
Diámetro de émbolo	8, 10	12, 16	20	25	32	40	50	63	80	100
Carrera [mm]	1 ... 100	1 ... 200	1 ... 250		1 ... 500					
Guía										
FEN/FENG-...-GF	Guía de deslizamiento									
FEN/FENG-...-KF	Guía de rodamiento de bolas									
Tipo de fijación	Con rosca interior									
Posición de montaje	Indistinta									
Temperatura ambiente [°C]	-20 ... +80									

Pesos [g]										
Tipo	FEN-...				FENG-...					
Diámetro de émbolo	8, 10	12, 16	20	25	32	40	50	63	80	100
Guía de deslizamiento (GF)										
Peso básico con carrera de 0 mm	332	490	873	866	1570	2480	4190	5540	10720	13420
Peso adicional por 10 mm de carrera	10	13	13	13	17	31	47	48	70	70
Guía de rodamiento de bolas (KF)										
Peso básico con carrera de 0 mm	300	429	828	813	1530	2370	4030	5410	10430	12990
Peso adicional por 10 mm de carrera	11	14	14	14	18	32	50	49	80	80

Materiales

Vista en sección

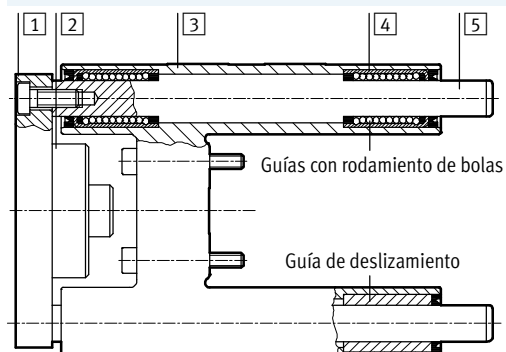

Unidad de guía	FEN/FENG-...-GF	FEN/FENG-...-KF
1 Yugo	32 ... 63 80, 100	Aluminio Acero
2 Acoplamiento	Acero	Acero
3 Guía	Aluminio	Aluminio
4 Soportes	Bronce sinterizado	Acero
5 Barras de guía	Acero	Acero
- Calidad del material	-	Sin cobre, ni PTFE
Conformidad con RoHS		

Unidades de guía FEN/FENG para cilindros normalizados

Hoja de datos

Carga útil máx. F en función del avance A

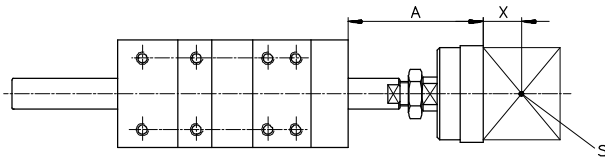

- A = Avance
- X = Distancia del centro de gravedad de la carga útil
- S = Centro de gravedad de la carga útil

∅ 8 ... 25

FEN-...-GF

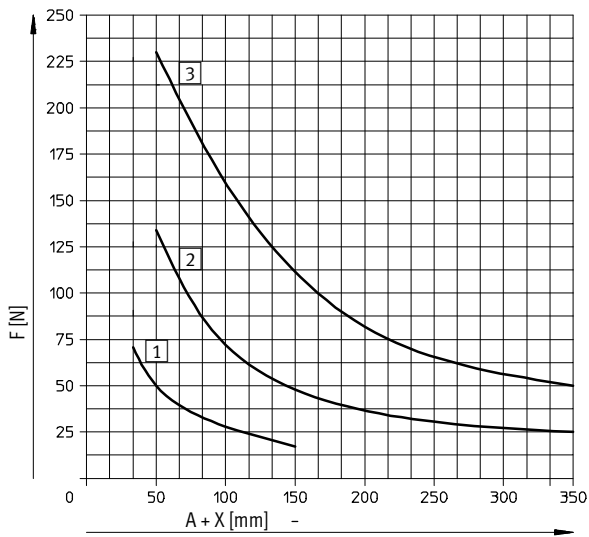

FEN-...-KF

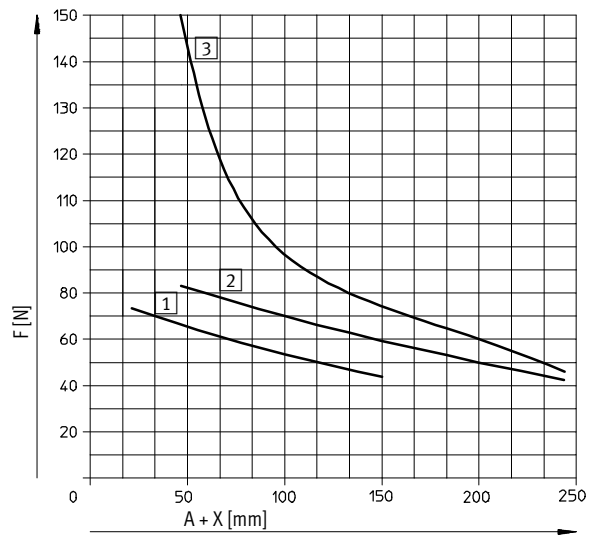

- 1 ∅ 8, 10
- 2 ∅ 12, 16
- 3 ∅ 20, 25

∅ 32 ... 100

FENG-...-GF

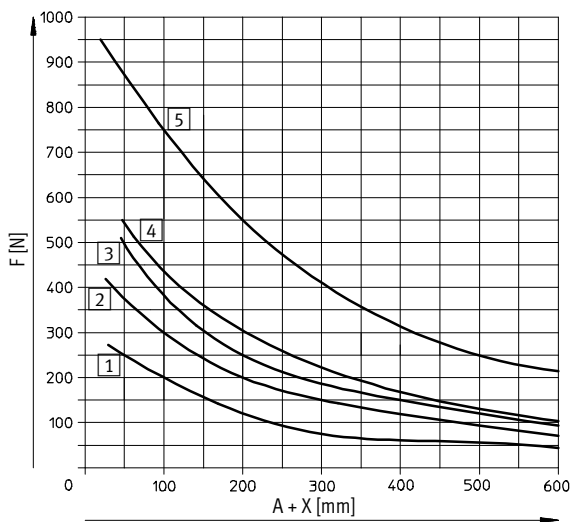

FENG-...-KF

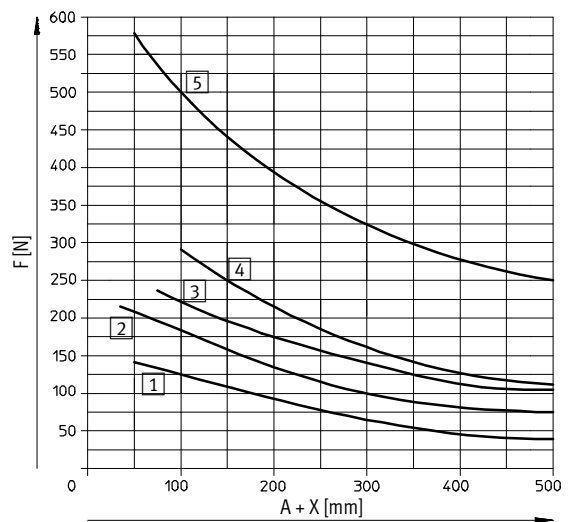

- 1 ∅ 32
- 2 ∅ 40
- 3 ∅ 50
- 4 ∅ 63
- 5 ∅ 80, 100

Unidades de guía FEN/FENG para cilindros normalizados

Hoja de datos

Dimensiones

Datos CAD disponibles en → www.festo.com

FEN-8, 10

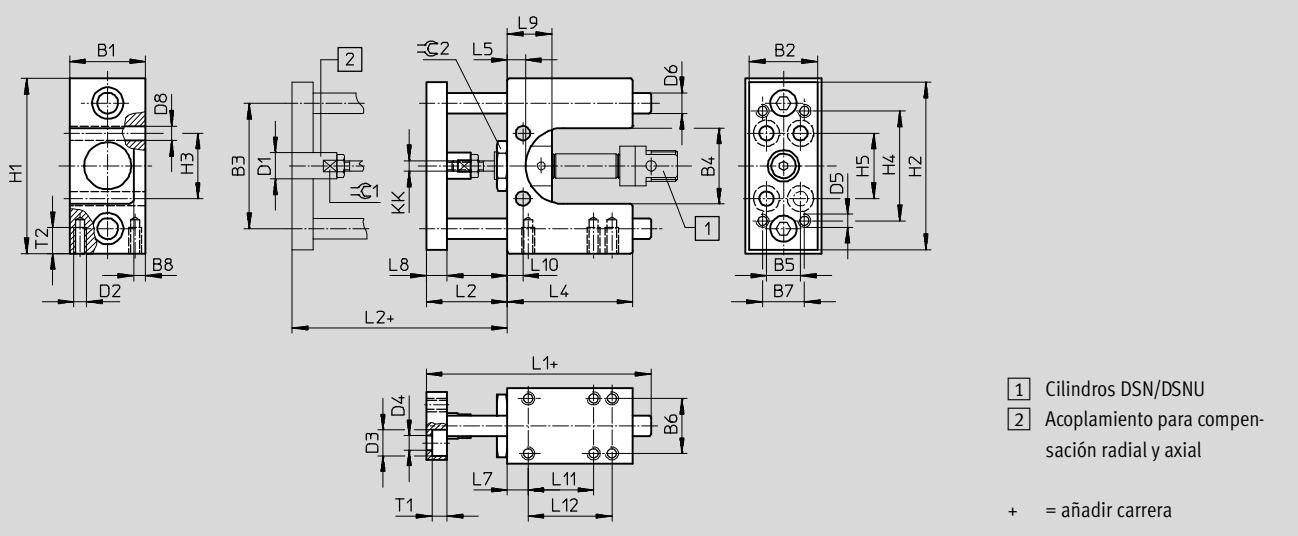

∅	B1	B2	B3	B4	B5	B6	B7	B8	D1	D2	D3	D4	D5	D6 ¹⁾	D8	H1	H2
[mm]	-0,3		±0,15						∅		∅	∅		∅	∅	-0,4	
8	29	26	48	29	13	21	16	4,5	10	M5	10	5,5	M5	8	5,5	67	64
10																	

∅	H3	H4	H5	KK	L1	L2	L4	L5	L7	L8	L9	L10	L11	L12	T1	T2	≈C1	≈C2
[mm]						+2												
8	25	42	25	M4	86	31	48	7	8	8	17	6	25	32	5,7	10	9	19
10																		

1) FENG-...-GF : Clase de tolerancia f8
FENG-...-KF: Clase de tolerancia h6

Unidades de guía FEN/FENG para cilindros normalizados

Hoja de datos

Dimensiones

Datos CAD disponibles en → www.festo.com

FEN-12, 16

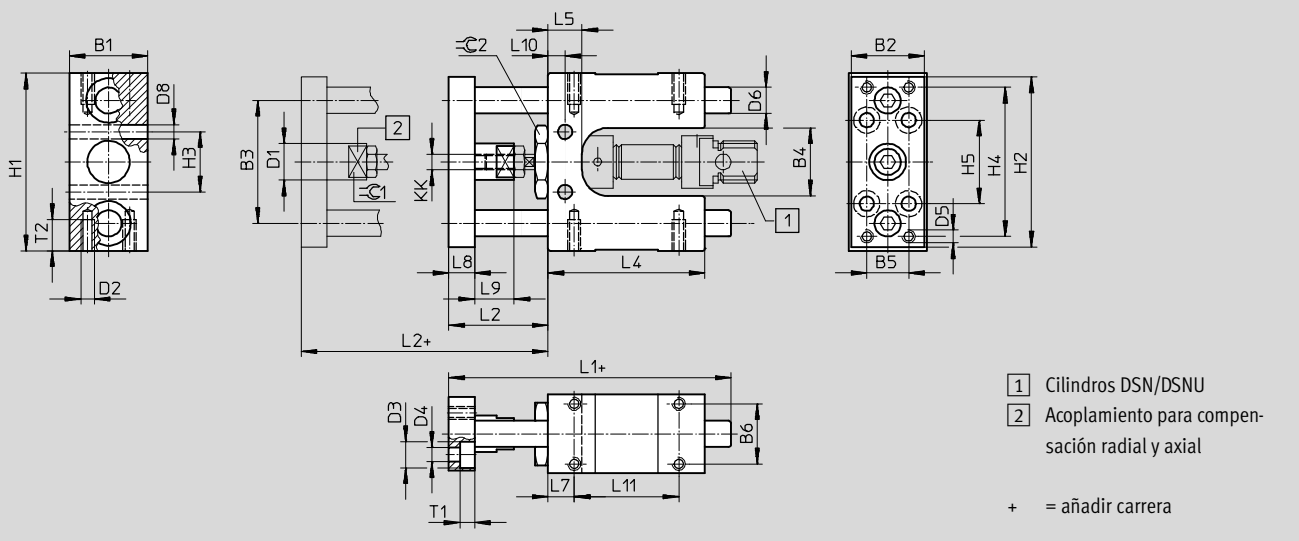

∅	B1	B2	B3	B4	B5	B6	D1	D2	D3	D4	D5	D6 ¹⁾	D8	H1	H2	H3
[mm]	-0,3		±0,15			±0,15	∅		∅	∅		∅	∅	-0,4		±0,15
12	30	28	47	26	16	23	14	M5	10	5,5	M5	10	5,5	68	65	23
16																

∅	H4	H5	KK	L1	L2	L4	L5	L7	L8	L9	L10	L11	T1	T2	$\text{C}1$	$\text{C}2$
[mm]					+5							±0,15				
12	57	32	M6	108	38	60	13	10	10	15	6,5	40	5,7	12	12	24
16																

1) FENG-...GF: Clase de tolerancia f8
FENG-...KF: Clase de tolerancia h6

Unidades de guía FEN/FENG para cilindros normalizados

Hoja de datos



Dimensiones

Datos CAD disponibles en → www.festo.com

FEN-20, 25

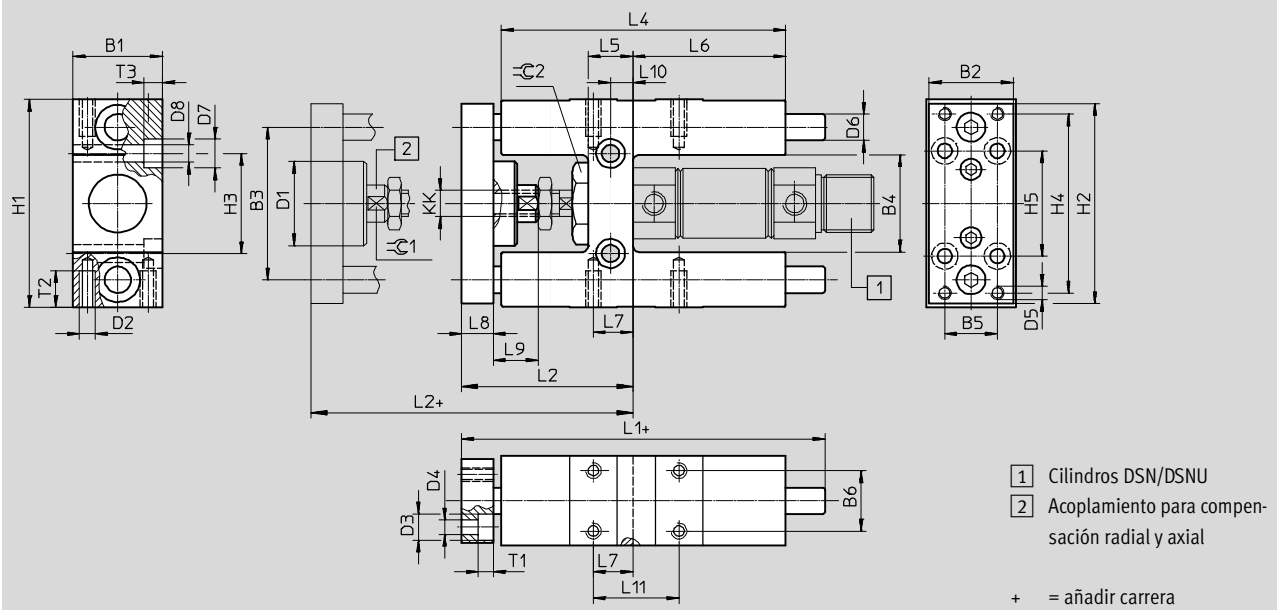

∅	B1	B2	B3	B4	B5	B6	D1	D2	D3	D4	D5	D6 ¹⁾	D7	D8	H1	H2	H3	H4
[mm]	-0,3		±0,2				∅		∅	∅		∅	∅	∅	-0,4		±0,2	
20	34	32	58	37	20	23	32	M6	10	5,5	M5	10	11	6,6	79	76	38	68
25																		

∅	H5	KK	L1	L2	L4	L5	L6	L7	L8	L9	L10	L11	T1	T2	T3	⊖C1	⊖C2
[mm]				+5								±0,2					
20		M8															
25	40	M8x1,25	138	65	108	17	58	15	12	22 17	8,5	32,5	5,7	14	6,8	13	27

1) FENG...-GF : Clase de tolerancia f8
FENG...-KF: Clase de tolerancia h6

Unidades de guía FEN/FENG para cilindros normalizados

Hoja de datos

Dimensiones

Datos CAD disponibles en → www.festo.com

FENG-32 ... 100

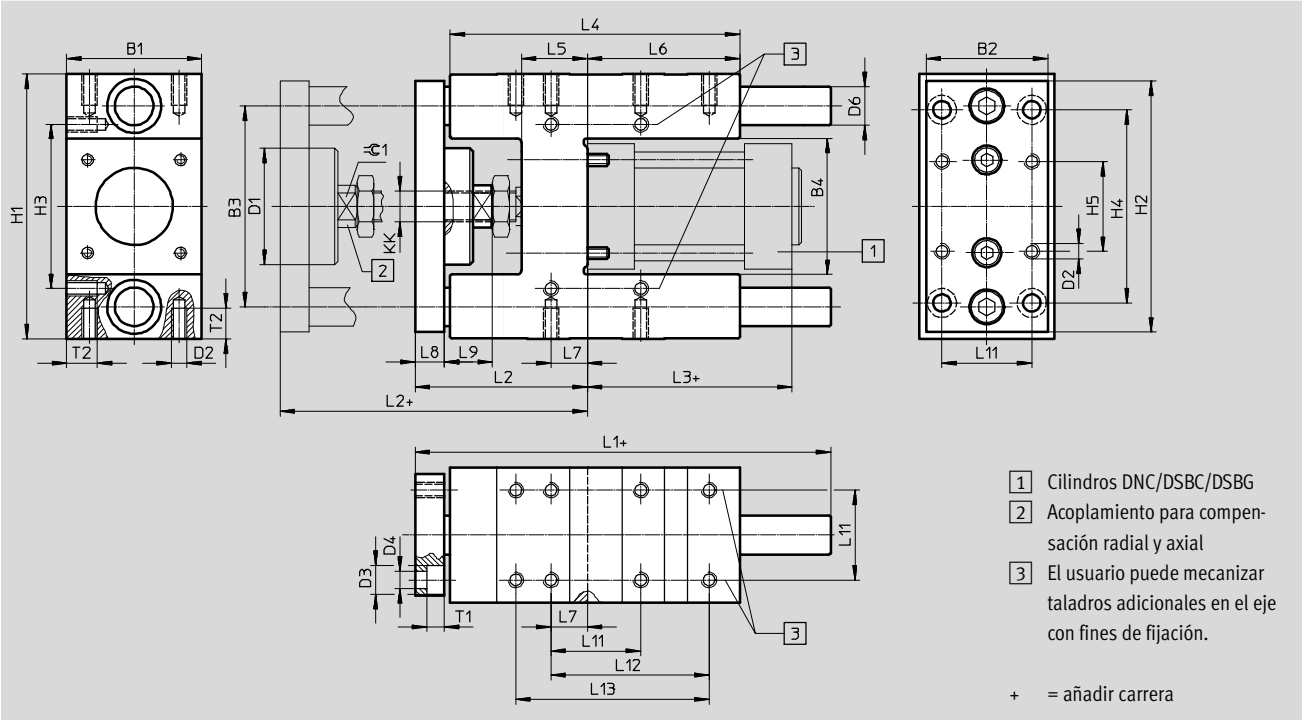

∅	B1	B2	B3	B4	D1	D2	D3	D4	D6 ¹⁾	H1	H2	H3	H4	H5	KK
[mm]	-0,3		±0,2		∅		∅	∅	∅			±0,2	±0,2	±0,2	
32	50	45	74	50,5 ±0,3	45	M6	11	6,6	12	97 -0,4	90	61	78	32,5	M10x1,25
40	58	54	87	58,5 ±0,3	45	M6	11	6,6	16	115 -0,4	110	69	84	38	M12x1,25
50	70	63	104	70,5 ±0,3	60	M8	15	9	20	137 -0,5	130	85	100	46,5	M16x1,5
63	85	80	119	85,5 ±0,3	60	M8	15	9	20	152 -0,5	145	100	105	56,5	M16x1,5
80	105	100	148	106 ±0,6	78	M10	18	11	25	189 -0,5	180	130	130	72	M20x1,5
100	130	120	172	131 ±0,6	78	M10	18	11	25	213 -0,5	200	150	150	89	M20x1,5

∅	L1	L2	L3	L4	L5	L6	L7	L8	L9	L11	L12	L13	T1	T2	≈C1
[mm]										±0,2	±0,2	±0,2		max.	
32	155	67 +5	94	125	24	76	4,3	12	20	32,5	70,3	78	6,5	14	15
40	170	75 +5	105	140	28	81	11	12	22	38	84	-	6,5	14	15
50	188	89 +10	106	150	34	79	18,8	15	25	46,5	81,8	100	9	16	19
63	220	89 +10	121	182	34	111	15,3	15	25	56,5	105	-	9	16	19
80	258	111 +10	128	215	40	128	21	20	32	72	-	-	11	20	27
100	263	116 +10	138	220	40	128	24,5	20	32	89	-	-	11	20	27

1) FENG-...GF : Clase de tolerancia f8
 FENG-...KF: Clase de tolerancia h6

Unidades de guía FEN/FENG para cilindros normalizados

Hoja de datos

Referencias FEN... para carreras variables					
Para cilindros normalizados DSN/DSNU					
Diámetro de émbolo [mm]	Carrera [mm]	Con guía de deslizamiento		Con guía de rodamiento de bolas	
		Nº de art.	Tipo	Nº de art.	Tipo
8, 10	1 ... 100	35196	FEN-8/10-...-GF	35197	FEN-8/10-...-KF
12, 16	1 ... 200	19168	FEN-12/16-...-GF	33481	FEN-12/16-...-KF
20	2 ... 250	19169	FEN-20-...-GF	33482	FEN-20-...-KF
25	2 ... 250	19170	FEN-25-...-GF	33483	FEN-25-...-KF

Referencias FENG... para carreras variables					
Para cilindros normalizados DNC/DSBC/DSBG					
Diámetro de émbolo [mm]	Carrera [mm]	Con guía de deslizamiento		Con guía de rodamiento de bolas	
		Nº de art.	Tipo	Nº de art.	Tipo
32	10 ... 500	34481	FENG-32-...-GF	34487	FENG-32-...-KF
40		34482	FENG-40-...-GF	34488	FENG-40-...-KF
50		34483	FENG-50-...-GF	34489	FENG-50-...-KF
63		34484	FENG-63-...-GF	34490	FENG-63-...-KF
80		34485	FENG-80-...-GF	34491	FENG-80-...-KF
100		34486	FENG-100-...-GF	34492	FENG-100-...-KF

Referencias: FENG-...-KF con guía de rodamiento de bolas para carreras fijas								
Para cilindros normalizados DNC/DSBC/DSBG								
Diámetro de émbolo [mm]	Nº de art. Tipo		Nº de art. Tipo		Nº de art. Tipo		Nº de art. Tipo	
	Carrera	50 mm		100 mm		160 mm		200 mm
32	34493	FENG-32-50-KF	34494	FENG-32-100-KF	34495	FENG-32-160-KF	34496	FENG-32-200-KF
40	34499	FENG-40-50-KF	34500	FENG-40-100-KF	34501	FENG-40-160-KF	34502	FENG-40-200-KF
50	34506	FENG-50-50-KF	34507	FENG-50-100-KF	34508	FENG-50-160-KF	34509	FENG-50-200-KF
63	34513	FENG-63-50-KF	34514	FENG-63-100-KF	34515	FENG-63-160-KF	34516	FENG-63-200-KF
80	34521	FENG-80-50-KF	34522	FENG-80-100-KF	34523	FENG-80-160-KF	34524	FENG-80-200-KF
100	34529	FENG-100-50-KF	34530	FENG-100-100-KF	34531	FENG-100-160-KF	34532	FENG-100-200-KF
Carrera	250 mm		320 mm		400 mm		500 mm	
32	150289	FENG-32-250-KF	34497	FENG-32-320-KF	150290	FENG-32-400-KF	34498	FENG-32-500-KF
40	34503	FENG-40-250-KF	34504	FENG-40-320-KF	150291	FENG-40-400-KF	34505	FENG-40-500-KF
50	34510	FENG-50-250-KF	34511	FENG-50-320-KF	150292	FENG-50-400-KF	34512	FENG-50-500-KF
63	34517	FENG-63-250-KF	34518	FENG-63-320-KF	34519	FENG-63-400-KF	34520	FENG-63-500-KF
80	34525	FENG-80-250-KF	34526	FENG-80-320-KF	34527	FENG-80-400-KF	34528	FENG-80-500-KF
100	34533	FENG-100-250-KF	34534	FENG-100-320-KF	34535	FENG-100-400-KF	34536	FENG-100-500-KF