

Compact Vision Systems SBOC-Q/SBOI-Q



Compact Vision Systems SBOC-Q/SBOI-Q

Key features



Mode of operation

The camera not only contains the sensor system for image data acquisition, but also the complete electronic evaluation unit for image processing, an integrated PLC and the interfaces for communication with higher-level controllers.

The CheckKon and CheckOpti software tools make configuring the image processing task very straightforward. The user creates reference images with

the camera by presenting different sample parts and then defines the desired inspection criteria. These can include, for example, brightness, distance, angle and circularity, but also the reading of text and/or 1D or 2D codes. The sample parts define the tolerance range, within which parts are identified as good, for each inspection characteristic. Up to 256 characteristics can be combined

in a single program and up to 256 inspection programs can be stored on the camera.

The camera can also be used to carry out sorting functions, as it is capable of storing and distinguishing between up to 16 different part types per inspection program.

The characteristics calculated by the camera are not dependent on the rotary orientation and position of the

inspection part, as they are determined relative to the position of the inspection part – any tilting and/or movement of the inspection part in the field of vision is therefore irrelevant for the inspection process.

The behaviour of the camera during inspection is determined by the evaluation mode. There are four different modes.

Evaluation modes

Mode	Function		Application
Triggered	Frame capture and inspection with each valid triggering signal. The triggering signal is generated by a master controller or a sensor as soon as the inspection part is in front of the	camera. The inspection results are output following the inspection, and the camera then waits for the next valid triggering signal.	Inspection of single parts when there is a triggering signal for image capture.
Idle run with image trigger with Compact Vision System SBO...-Q-R...B	Image capture is performed continuously, but image evaluation only if there is an inspection part in front of the camera, i.e. if the trigger condition has been satisfied in a freely defined	image area (e.g. a specific brightness is exceeded/fallen below). The inspection results are output following the inspection. The camera then waits for the next image-based trigger.	Inspection of single parts at a medium to fast rate without an external sensor.
Idle run without image trigger	Image capture and inspection (without fixed frame rate) are performed continuously. The triggering signal is permanently present, irrespective of whether or not there is an inspection part in front of the camera. The	camera acts like a basic sensor. The inspection results are output following the inspection, and the camera then starts the next inspection immediately.	Inspection of single or continuous parts at a medium to fast (continuous) rate.
Fixed frame rate with Compact Vision Systems SBO...-Q-R1 and SBO...-Q-R2	Image capture and inspection are performed continuously at a defined frame rate. The triggering signal is permanently present. The inspection	results are output following the inspection. The camera starts the next inspection in accordance with the defined frame rate.	Inspection of continuous parts at a constant speed.

Programming

Integrated PLC



The integrated PLC can be programmed in all programming languages covered by IEC 61131-3 (e.g. LDR, ST, sequential function chart, etc.) using the software tool CODESYS provided by Festo. The predefined function blocks enable

straightforward data exchange between the image processing task and the integrated PLC. This provides an easy means of implementing extensive inspection tasks or even communication between different cameras.

Compact Vision Systems SBOC-Q/SBOI-Q

Key features

Interfaces

Connection and display components

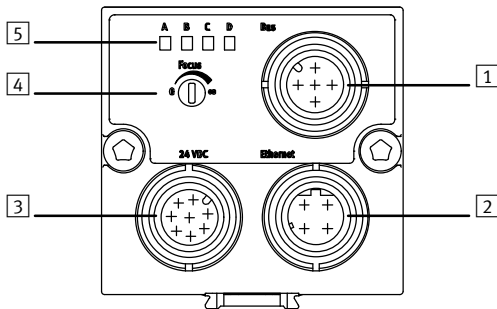

- 1 Fieldbus connection for Compact Vision Systems SBO...-Q-R1 and SBO...-Q-R2
- 2 Ethernet connection
- 3 Operating voltage supply and inputs/outputs
- 4 Adjusting screw for focus
- 5 Status LEDs:
 - A Ready status
 - B Ethernet traffic
 - C Activity
 - D Output

Inputs:

- Camera trigger
- Error acknowledgment

Outputs (can be parameterised):

- Ready status
- Good part correctly oriented
- Good part incorrectly oriented
- Reject part
- Error
- Warning
- External lighting

Ethernet – TCP/IP

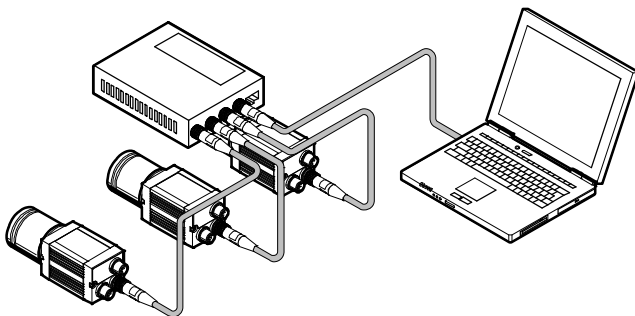

Commissioning and diagnostics:

- PC for configuration and for diagnostics with TCP/IP
- Integration of the camera in a corporate network (integrated web server)

- Visualisation of the camera images and inspection results via SBO...-Q WebViewer

Ethernet – TCP/IP, EasyIP, Telnet, Modbus TCP

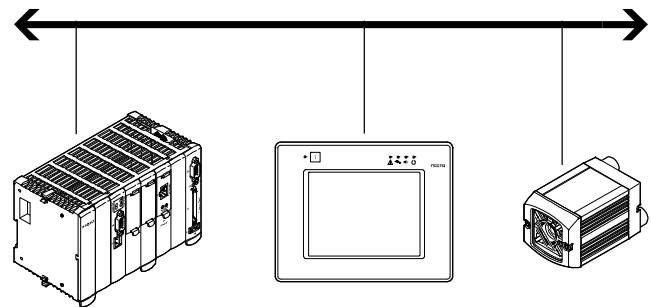

All parameters can be modified and all inspection results and characteristic values can be read via the Ethernet interface with EasyIP, Telnet and Modbus TCP.

- Front End Display FED, e.g. for teach-in, status signals, type selection or parameter modification
- Robot controllers and programmable logic controllers, e.g. CECX for reading characteristic values (e.g. coordinates and rotation angle)

CANopen master functionality

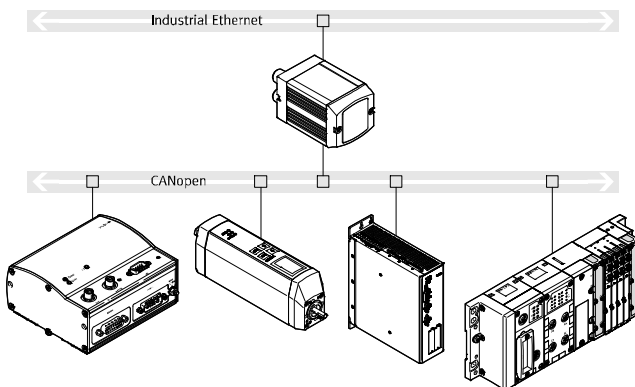

Servo controllers and remote I/O can be addressed directly via the CANopen master functionality.

Compact Vision Systems SBOC-Q/SBOI-Q

Key features



Interfaces (continued)

CAN – Vision system as CPI module

For Compact Vision Systems SBO...-Q-R1 and SBO...-Q-R2

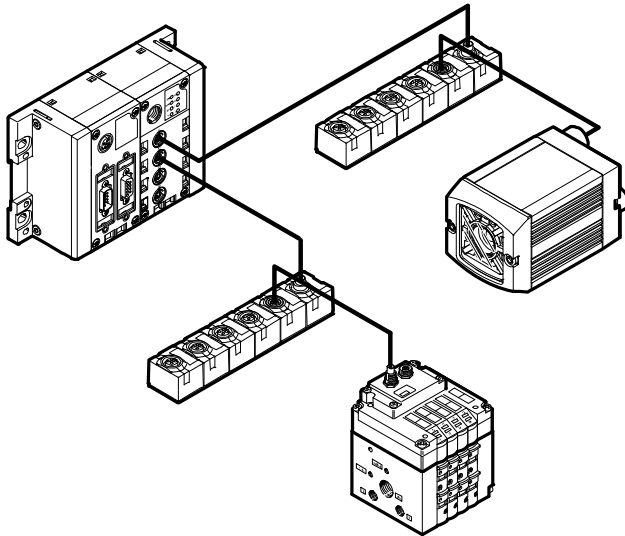

- The Compact Vision System SBO...-Q can be integrated into a Festo CPI module. In this case it functions like a binary module with 16 inputs and outputs.
- In combination with a CPX-CPI module and a CPX bus node, for example, the camera can be accessed via PROFIBUS DP, INTERBUS, DeviceNet, CANopen, CC-Link, EtherNet/IP, PROFINET, POWERLINK, EtherCAT and Sercos III.

CAN – I/O expansion

For Compact Vision Systems SBO...-Q-R1 and SBO...-Q-R2

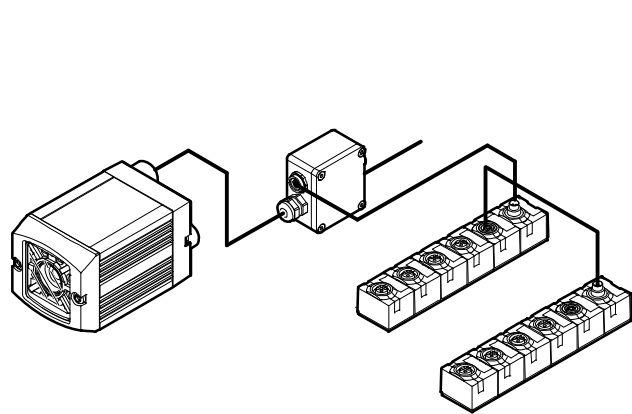

- An input and output module can be connected to the camera via the camera's CAN interface.
- Input module CP-E08-M12-CL for binary preselection of the inspection program
- Output module CP-A04-M12-CL for binary signalling of part types

Software

CheckKon

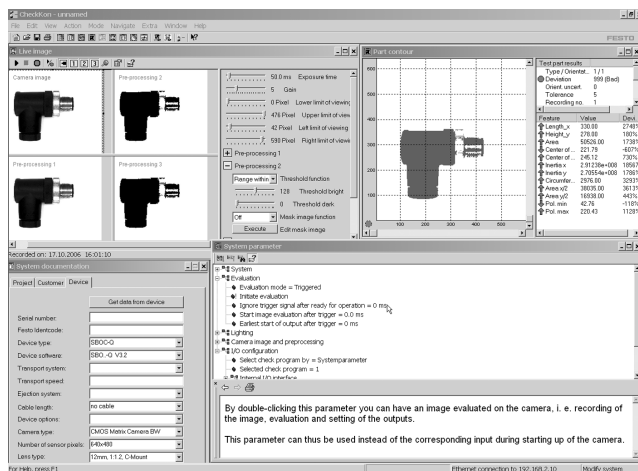

Using the CheckKon software, all processes within the camera – from image capture to the input and output parameters – can be displayed, logged and modified.

This includes:

- Selecting the evaluation mode
- Displaying and editing system parameters
- Displaying analysis of most recently inspected parts
- Displaying and logging inspection part images and the characteristics derived from them
- Loading new inspection programs
- System documentation

Compact Vision Systems SBOC-Q/SBOI-Q

Key features



CheckOpti

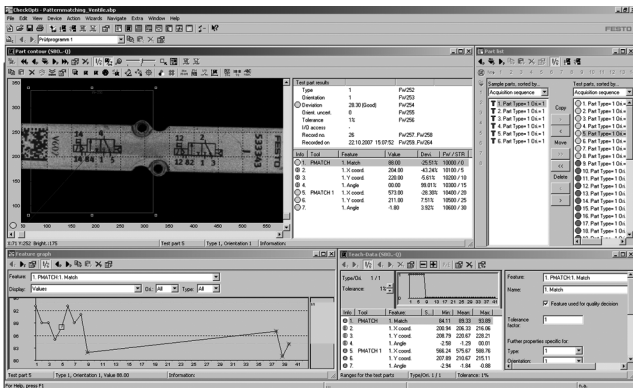

CheckOpti is used to configure inspection programs. Following the presentation of sample parts, the user defines the characteristics to be inspected with the aid of the software. This is done by selecting the characteristics from a list and then dragging and dropping them to the area of the sample part to be inspected. A total of 256 performance characteristics can thus be defined and optimised within the framework of an inspection program. The inspection program can then be uploaded to one of the camera's 256 memory locations.

Examples of inspection characteristics:

- Vertical length measurement
- Horizontal length measurement
- Angle measurement
- Counting of events
- Measurements on the inspection part contour
- Area definition
- Calculation of grey tone or colour differences

Application examples

Quality inspection of tube with union nut

The inspection takes place with back-lighting; calculated characteristics:

- Length of nut
- Threaded coupling distances
- Diameter of tube
- Thread outside diameter
- Angle measurement on the flange
- Circumference of the screw
- Area of the screw

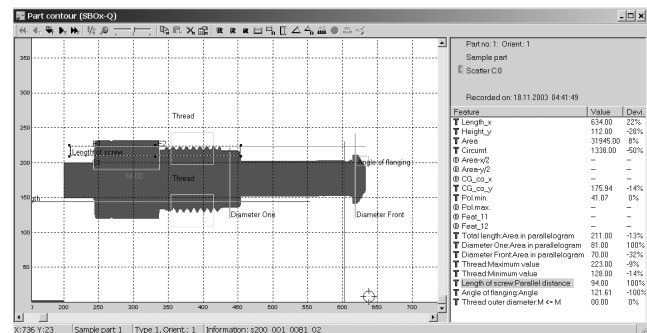
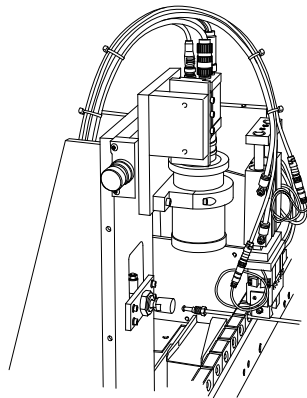

Screw type differentiation

The inspection takes place with reflected light; calculated characteristics:

- Centre of gravity coordinates x, y
- Average grey tone of area
- Angle of screw drive to horizontal

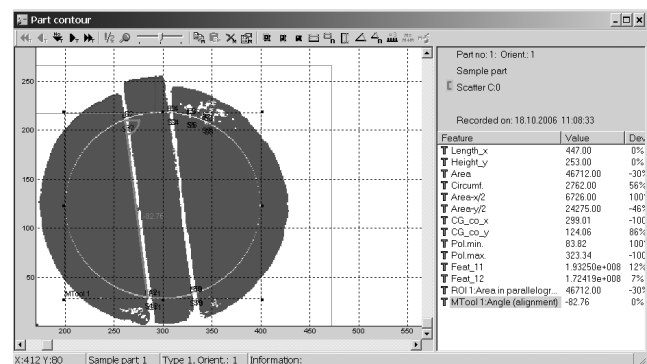
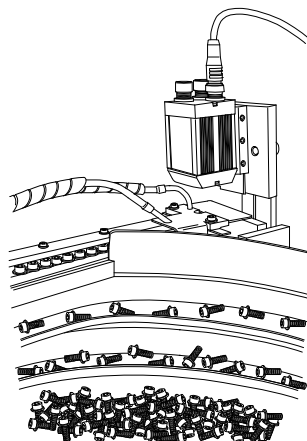

Compact Vision Systems SBOC-Q/SBOI-Q

Peripherals overview

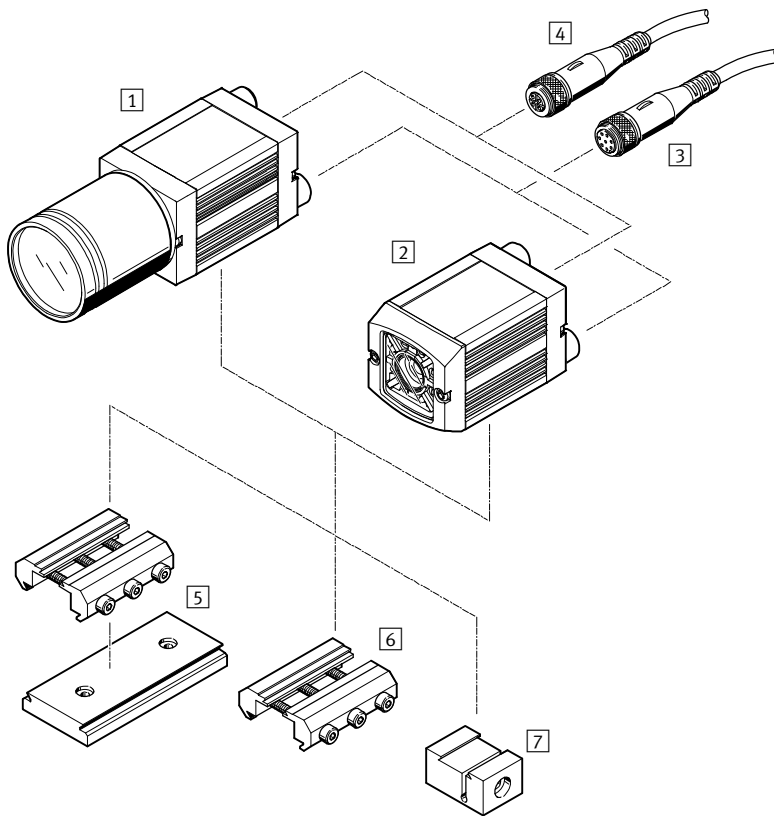

Accessories	Brief description	→ Page/Internet
Compact Vision System		
1 SBOC-Q-...	For standard lenses with C mount or CS mount ¹⁾ connection	8
2 SBOI-Q-...	With integrated lens and light	
Plug socket with cable		
3 SIM-M12-8GD-...-PU	For supplying the operating voltage	15
Cable		
4 SBOA-K30E-M12S	Ethernet diagnostic cable	15
- SBOA-K20CP-WS	For integration in a CPI system	
- SBOA-K20CP-SUP	For I/O expansion	
Lens		
- SASF-C-L-F...	Focal length 6 ... 35 mm	14
Mounting attachments		
5 Adapter kit SBOA-HMSV-39	With screw-on adapter plate	13
6 Adapter kit SBOA-HMSV-40	Without screw-on adapter plate	
7 Adapter kit SBOA-HMSV-41	With female thread G¼ for mounting on commercially available tripods	
- Adapter SBOL-C-5	5 mm spacer ring (CS mount to C mount)	13

1) CS mount without protective tube.

Compact Vision Systems SBOC-Q/SBOI-Q

Type codes

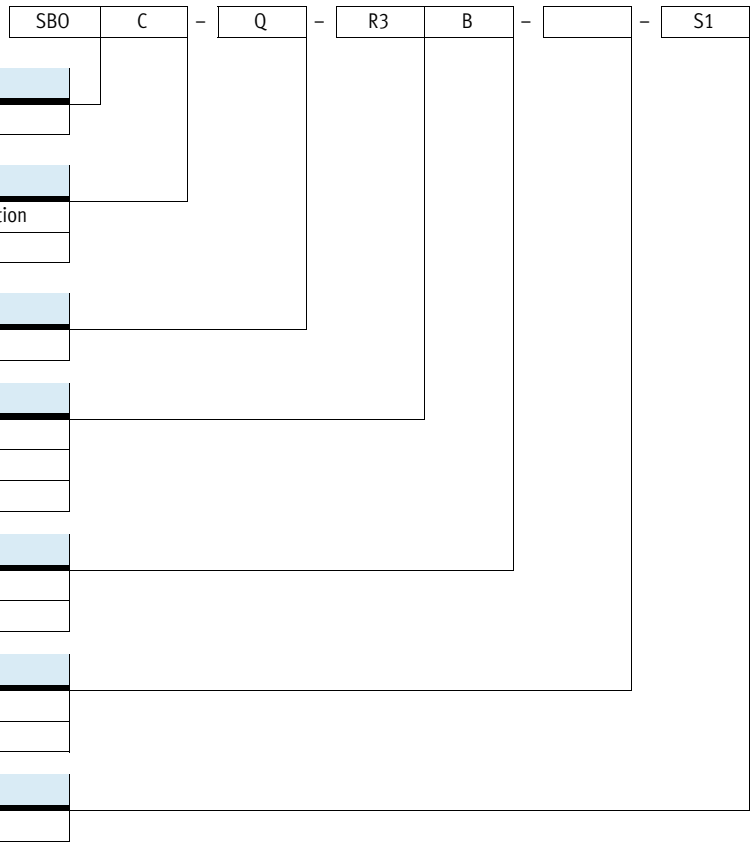

1) CS mount without protective tube.

Compact Vision Systems SBOC-Q/SBOI-Q

FESTO

Technical data

-  Voltage
24 V DC

-  Temperature range
-10 ... +50 °C

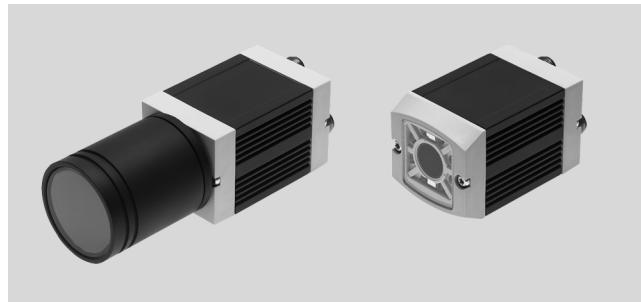

General technical data						
Type		SBOC-Q-R1	SBOI-Q-R1	SBOC-Q-R3	SBOI-Q-R3	SBOC-Q-R2
Sensor resolution	[pixels]	640 x 480		752 x 480		1,280 x 1,024
Exposure time	[ms]	0.039 ... 1,000		0.018 ... 200		0.008 ... 1,000
Frame rate (full image)	[fps]	150		60		27
Sensor type		Monochrome		Monochrome		Monochrome
				Colour		Colour
Lens mounting		C mount	Integrated lens	C mount	Integrated lens	C mount
		CS mount ¹⁾		CS mount ¹⁾		CS mount ¹⁾
Operating distance	[mm]	Dependent on the lens selected	22 ... 1,000	Dependent on the lens selected	20 ... 550	Dependent on the lens selected
Field of vision	[mm]	Dependent on the lens selected	14x10 ... 520x390	Dependent on the lens selected	7.9x5.5 ... 195x125	Dependent on the lens selected
Max. no. of inspection programs		256		256		256
Max. no. of orientations		8 per part type		8 per part type		8 per part type
Sorting function		Up to 16 types per inspection program		-		Up to 16 types per inspection program

1) Without protective tube.

Electrical data			
Type		SBOC-Q	SBOI-Q
Nominal operating voltage	[V DC]	24	
Permissible voltage fluctuations	[%]	±10	
Current consumption with load-free outputs	[mA]	120	
Max. residual current	[A]	1.5 at the 24 V outputs	
Input 1		Trigger signal Used by CODESYS	
Input 2		Applying inputs Acknowledging errors Used by CODESYS	
Outputs		Good part Reject part Warning Error External lighting Used by CODESYS	
Protection class		IP65, IP67 ¹⁾	IP65, IP67

1) Only in combination with protective tube (included in the scope of delivery).

Compact Vision Systems SBOC-Q/SBOI-Q

Technical data

Electrical data			
Type	SBO...-Q-R1	SBO...-Q-R3	SBO...-Q-R2
Sensor resolution [pixels]	640 x 480	752 x 480	1,280 x 1,024
Ethernet interface			
Bus interface	IEEE802.3U (100BaseT)		
Connection technology	Plug M12		
Data transmission speed [Mbps]	100		
Supported protocols	TCP/IP		
	EasyIP		
	Telnet		
	ModbusTCP		
Fieldbus interface			
Type	CAN	-	CAN
Connector plug	Plug M12		Plug M12
Supported protocols	CP fieldbus		CP fieldbus

Operating and environmental conditions	
Ambient temperature [°C]	-10 ... +50
Storage temperature [°C]	-10 ... +60
Ambient conditions	Screened from extreme external light sources
	Cleanest possible ambient air
CE mark (see declaration of conformity) ¹⁾	In accordance with EU EMC Directive
Certification	c UL us Recognized (OL)
	C-Tick

- 1) For information about the applicability of the component see the manufacturer's EC declaration of conformity at: www.festo.com/sp → User documentation.
If the component is subject to restrictions on usage in residential, office or commercial environments or small businesses, further measures to reduce the emitted interference may be necessary.

Materials	
Housing	Anodised aluminium
Cap	ABS, fibre glass reinforced
Note on materials	Free of copper and PTFE
	RoHS-compliant

Weight [g]					
Lens mounting	C mount/CS mount ¹⁾			Integrated lens	
Type	SBOC-Q-R1	SBOC-Q-R3	SBOC-Q-R2	SBOI-Q-R1	SBOI-Q-R3
Compact Vision System	182	172	182	184	174

- 1) CS mount without protective tube.

Compact Vision Systems SBOC-Q/SBOI-Q

Technical data

FESTO

Dimensions

Download CAD data → www.festo.com

C mount/CS mount¹⁾ SBOC-Q-R1/-R2

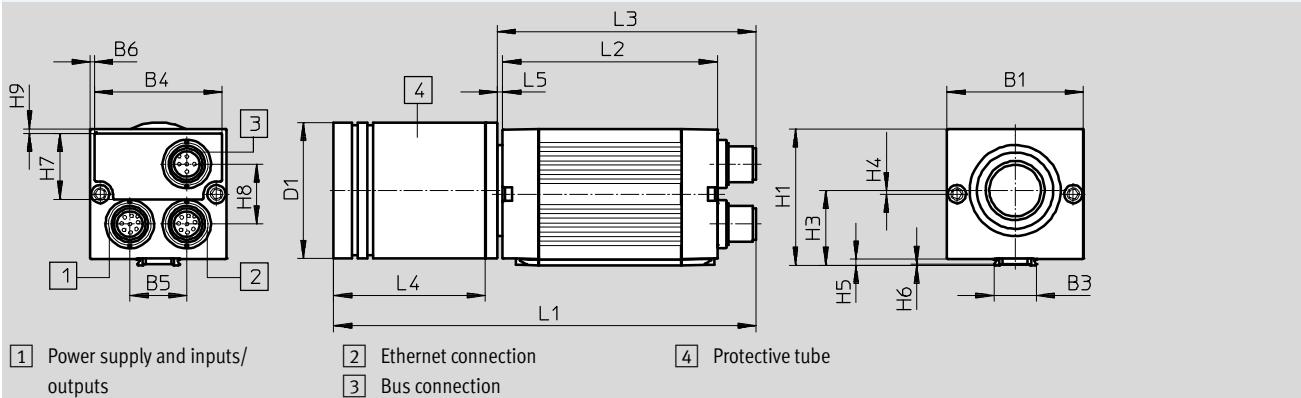

C mount/CS mount¹⁾ SBOC-Q-R3

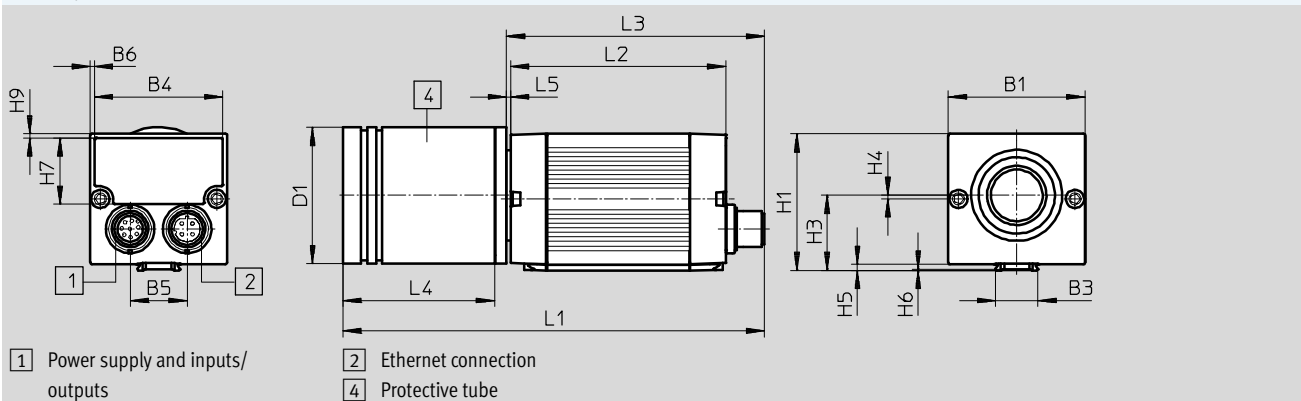

1) CS mount without protective tube.

Type	B1	B3	B4	B5	B6	D1 ∅	H1	H3	H4	H5	H6	H7	H8	H9	L1	L2	L3	L4	L5
SBOC-Q-R1/-R2	45	13.91	42.2	18.8	1.4	45	45	24.65	1.15	2	0.3	21.8	19.8	1.4	139.4	71	85.4	50	1.7
SBOC-Q-R3													-		139		85		1.3

Compact Vision Systems SB0C-Q/SB0I-Q

Technical data

Dimensions

Download CAD data → www.festo.com

Integrated lens SB0I-Q-R1

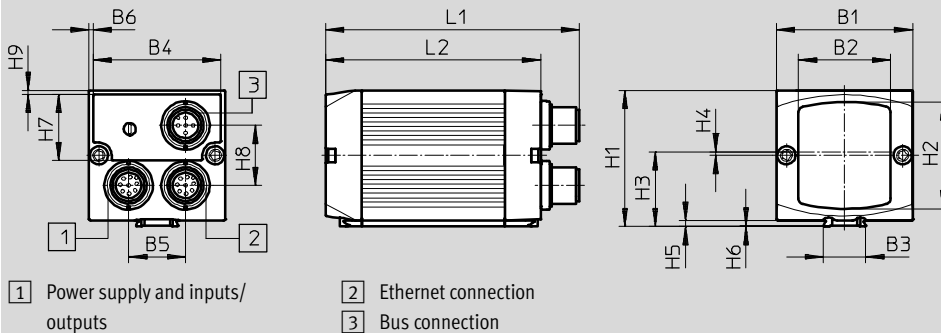

Integrated lens SB0I-Q-R3

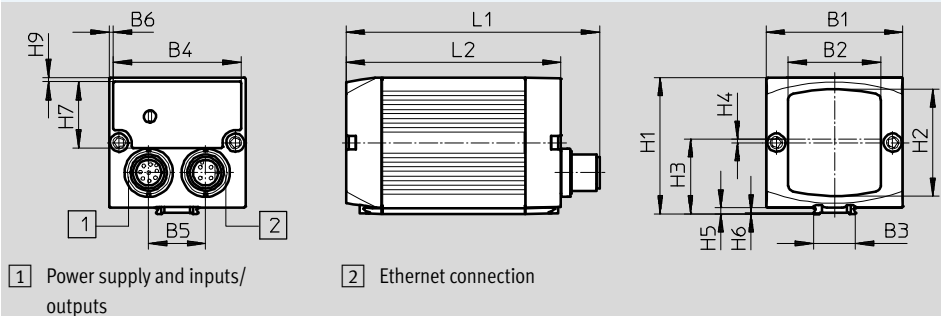

Type	B1	B2	B3	B4	B5	B6	H1	H2	H3	H4	H5	H6	H7	H8	H9	L1	L2
SB0I-Q-R1	45	30.2	13.91	42.2	18.8	1.4	45	35	24.65	1.15	2	0.3	21.8	19.8	1.4	83.7	71
SB0I-Q-R3														-			

Compact Vision Systems SBOC-Q/SBOI-Q



Technical data

Ordering data			
	Sensor type	Part No.	Type
640 x 480 pixels, VGA resolution			
For standard lenses with C mount or CS mount ¹⁾ connection	Monochrome	541399	SBOC-Q-R1B
		569771	SBOC-Q-R1B-S1
Integrated lens	Monochrome	541396	SBOI-Q-R1B
		569773	SBOI-Q-R1B-S1
752 x 480 pixels, Wide VGA resolution			
For standard lenses with C mount or CS mount ¹⁾ connection	Monochrome	555841	SBOC-Q-R3B-WB
		569777	SBOC-Q-R3B-WB-S1
	Colour	555842	SBOC-Q-R3C-WB
		569778	SBOC-Q-R3C-WB-S1
Integrated lens	Monochrome	555839	SBOI-Q-R3B-WB
		569779	SBOI-Q-R3B-WB-S1
	Colour	555840	SBOI-Q-R3C-WB
		569780	SBOI-Q-R3C-WB-S1
1,280 x 1,024 pixels, SXGA resolution			
For standard lenses with C mount or CS mount ¹⁾ connection	Monochrome	551021	SBOC-Q-R2B
		569772	SBOC-Q-R2B-S1
For standard lenses with C mount or CS mount ¹⁾ connection	Colour	551022	SBOC-Q-R2C

1) CS mount without protective tube.

Compact Vision Systems SBOC-Q/SBOI-Q

Accessories

**Adapter kit
SBOA-HMSV-39**
with screw-on adapter plate

Material:
Anodised wrought aluminium alloy

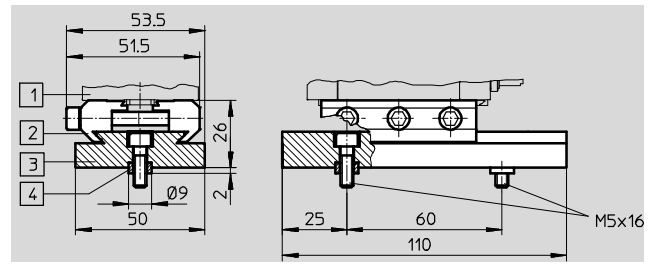
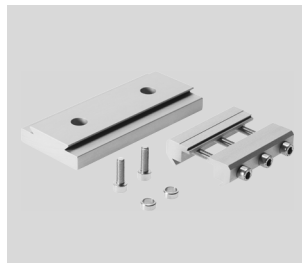

Ordering data	
Part No.	Type
Adapter kit	541599 SBOA-HMSV-39

**Adapter kit
SBOA-HMSV-40**
without screw-on adapter plate

Material:
Anodised wrought aluminium alloy

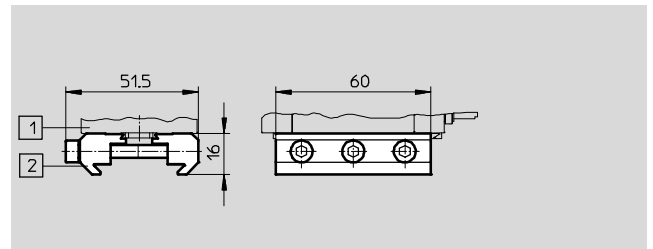

Ordering data	
Part No.	Type
Adapter kit	541600 SBOA-HMSV-40

**Adapter kit
SBOA-HMSV-41**
with female thread G1/4 for mounting
on commercially available tripods

Material:
Anodised wrought aluminium alloy

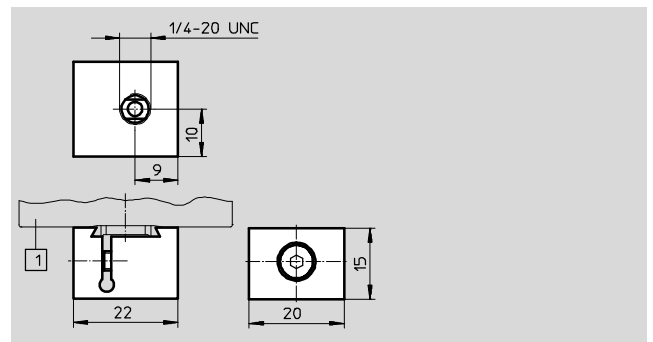

Ordering data	
Part No.	Type
Adapter kit	542140 SBOA-HMSV-41

Adapter SBOL-C-5
5 mm spacer ring
(CS mount to C mount)

Material:
Anodised wrought aluminium alloy

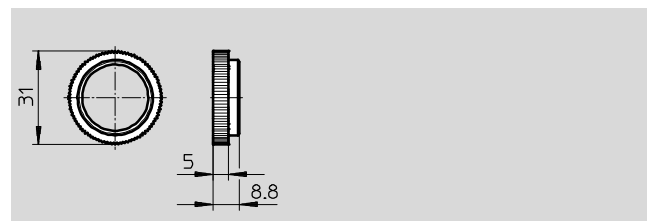

Ordering data	
Part No.	Type
Adapter	541601 SBOL-C-5

Compact Vision Systems SB0C-Q/SB0I-Q

Accessories



Lens SASF-C-L-F6

Focal depth 6 mm

Note on materials:
Contains PWIS (paint wetting
impairment substances)
RoHS-compliant

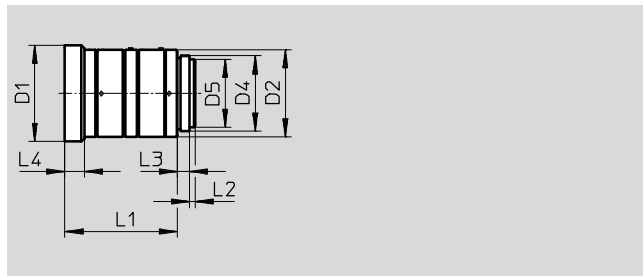

Lens SASF-C-L-F16

Focal depth 16 mm

Note on materials:
Contains PWIS (paint wetting
impairment substances)
RoHS-compliant

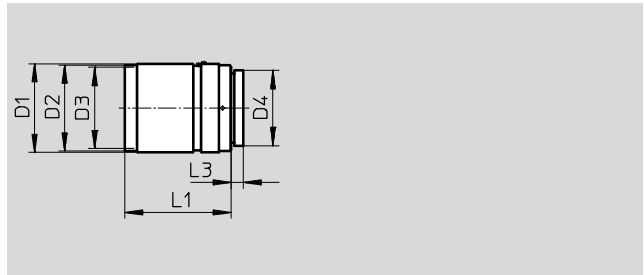

Lens SASF-C-L-F12/25/35

Focal depth 12/25/35 mm

Note on materials:
Contains PWIS (paint wetting
impairment substances)
RoHS-compliant

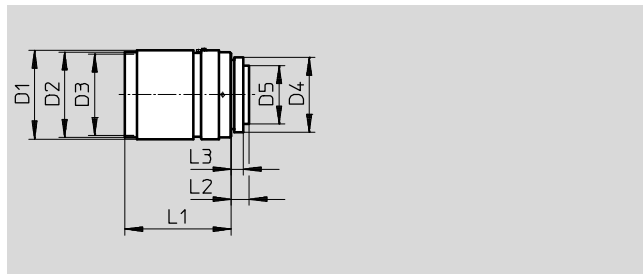



Dimensions									
Type	D1 Ø	D2 Ø	D3 Ø	D4	D5 Ø	L1	L2	L3	L4
SASF-C-L-F6	32	29	–	1-32UN	22.5	37.5	1.9	4	6.5
SASF-C-L-F16	29.5	28.5	27, P=0.5	1-32UN-2A	–	33.2	–	4	–
SASF-C-L-F12	29.5	28.5	27, P=0.5	1-32UN-2A	16.5	28.5	7.1	4	–
SASF-C-L-F25						32	6.9		
SASF-C-L-F35						19.5	35.4		



Ordering data – Lenses				Technical data → Internet: sasf-c		
	Brief description	Operating distance [mm]	Focal depth [mm]	Part No.	Type	
	C mount for Compact Vision System with sensor resolution R1 and R3	≥200	6	572910	SASF-C-L-F6	
	C mount for Compact Vision System with sensor resolution R1 and R3	≥250	12	572911	SASF-C-L-F12	
	C mount for Compact Vision System with sensor resolution R1, R2 and R3	≥250	16	572912	SASF-C-L-F16	
		≥250	25	572913	SASF-C-L-F25	
		≥350	35	572914	SASF-C-L-F35	

Compact Vision Systems SBOC-Q/SBOI-Q

Accessories

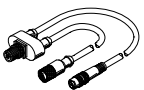
FESTO

Ordering data					
	Use	Connection	Cable length [m]	Part No.	Type
Plug socket with cable				Technical data → Internet: sim-m12	
	For supplying the operating voltage	Straight socket, M12x1, 8-pin Open end, 8-pin	2	525616	SIM-M12-8GD-2-PU
			5	525618	SIM-M12-8GD-5-PU
Cable				Technical data → Internet: sboa	
	Ethernet diagnostic cable	Straight socket, M12x1, 4-pin, D-coded RJ45 plug	3	542139	SBOA-K30E-M12S
	For integration in a CPI system	Straight socket, M12x1, 5-pin Angled plug, M9x0.5, 5-pin	2	548823	SBOA-K20CP-WS
	For I/O expansion	Straight socket, M12x1, 5-pin Straight socket, M9x0.5, 5-pin Straight plug, M12x1, 4-pin	2	548824	SBOA-K20CP-SUP

Ordering data – Documentation					
	Brief description	Language	Part No.	Type	
	Manual User manual in paper form is not included in the scope of delivery for the Compact Vision System	German	548318	P.BE-SBO-Q-DE	
		English	548319	P.BE-SBO-Q-EN	
	Documentation package User manual on CD-ROM is included in the scope of delivery for the Compact Vision System	German, English	549036	P.BE-SBO-Q-UDOK	

Ordering data – Software					
	Brief description	Language	Part No.	Type	
	CheckKon software	German, English	194496	P.SW-KON	
	CheckOpti software		568339	P.SW-OPTI	
	SBO...-Q Tools add-in software licence for unlocking tools on the Compact Vision System		570045	GSLO	