







Linear drives DDLI, with integrated displacement encoder



# Cylinders with displacement encoder

Product range overview



Function	Type	Description
Drives	<b>Rodless</b>	
	DDLI 	<ul style="list-style-type: none"> <li>• Without guide</li> <li>• With contactless measuring displacement encoder</li> <li>• Based on linear drive DGC-K</li> <li>• Supply ports on end face</li> <li>• System product for handling and assembly technology</li> </ul>
	DGCI 	<ul style="list-style-type: none"> <li>• With guide</li> <li>• With contactless measuring displacement encoder</li> <li>• Based on linear drive DGC</li> <li>• Supply ports optionally on end face or front</li> <li>• System product for handling and assembly technology</li> </ul>
	<b>With piston rod</b>	
	DNCI 	<ul style="list-style-type: none"> <li>• With contactless measuring displacement encoder</li> <li>• Various piston rod variants</li> <li>• Standard cylinder to ISO 15552</li> </ul> <p>ISO DIN VDMA</p>
	DDPC 	<ul style="list-style-type: none"> <li>• With contactless measuring displacement encoder</li> <li>• Various piston rod variants</li> <li>• Standard cylinder to ISO 15552</li> </ul> <p>ISO DIN VDMA</p>
	DNC/DSBC 	<ul style="list-style-type: none"> <li>• With attached potentiometer MLO-LWG</li> <li>• Various piston rod variants</li> <li>• Standard cylinder to ISO 15552</li> </ul> <p>ISO DIN VDMA</p>
Swivel module	<b>Swivel module</b>	
	DSMI 	<ul style="list-style-type: none"> <li>• Based on Swivel module DSM</li> <li>• Integrated rotary potentiometer</li> <li>• Compact design</li> <li>• Wide range of mounting options</li> </ul>

# Cylinders with displacement encoder

Product range overview



Piston∅	Stroke/swivel angle [mm/°]	Appropriate				
		For positioning with		For end-position controller		For use as a measuring cylinder
		CPX-CMAX	CPX-CMPX	SPC11		
<b>Rodless</b>						
25, 32, 40, 63	100, 160, 225, 300, 360, 450, 500, 600, 750, 850, 1000, 1250, 1500, 1750, 2000	■	■	■	■	
18, 25, 32, 40, 63	100, 160, 225, 300, 360, 450, 500, 600, 750, 850, 1000, 1250, 1500, 1750, 2000	■	■	■	■	
<b>With piston rod</b>						
32, 40, 50, 63	10 ... 2000	-	-	-	■	
	100 ... 750	■	■	■	-	
80, 100	10 ... 2000	-	-	-	■	
	100 ... 750	■	■	■	-	
32, 40, 50, 63, 80	100, 150, 225, 300, 360, 450, 600, 750	■	■	■	■	
<b>Swivel module</b>						
25, 40, 63	270	■	■	■	■	

# Cylinders with displacement encoder

Key features

## Servopneumatic drive technology

Positioning and Soft Stop applications as an integral component of the valve terminal CPX – the modular peripheral system for decentralised automation tasks.

The modular design means that valves, digital inputs and outputs, positioning modules and end-position controllers, as appropriate to the application, can be combined in almost any way on the CPX terminal.

Advantages:

- Pneumatics and electrics – control and positioning on one platform
- Innovative positioning technology – piston rod drives, rodless drives, rotary drives
- Actuation via fieldbus
- Remote maintenance, remote diagnostics, web server, SMS and e-mail alerts are all possible via TCP/IP
- Modules can be quickly exchanged and expanded without altering the wiring

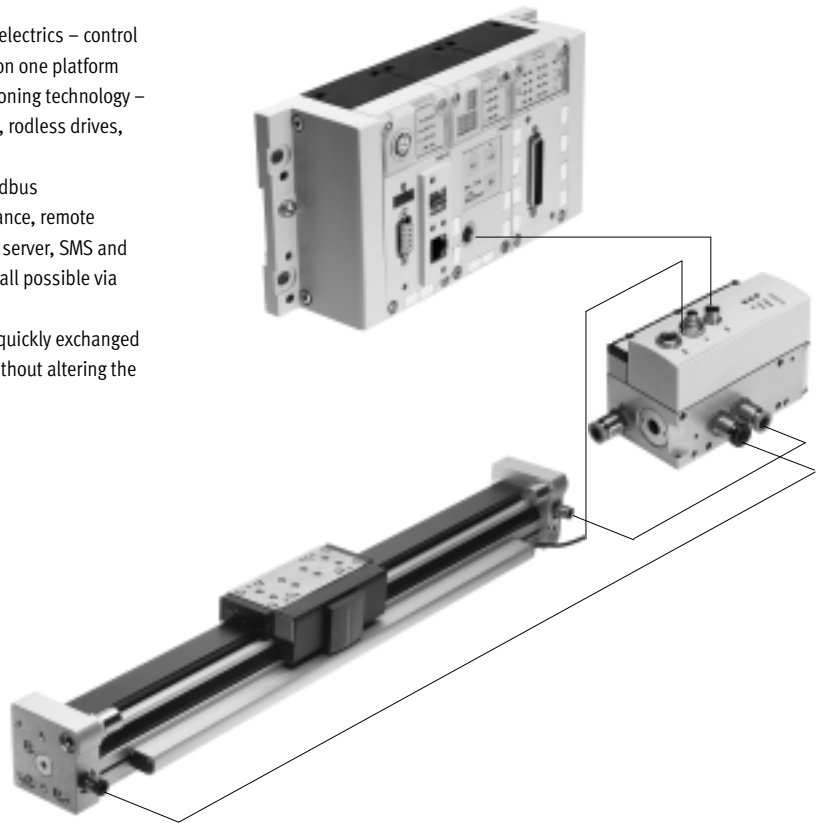

## Axis controller CPX-CMAX



Free choice:

Position and force control, directly actuated or selected from one of 64 configurable position sets.

If you are looking for something more:

the configurable function for switching to the next set enables easy functional sequences to be realised with the axis controller CPX-CMAX.

All stations are recognised:

the auto-identification function identifies each participant with its device data on the controller CPX-CMAX.

Also included:

The range of services of the controller CPX-CMAX includes control of a brake or clamping unit via the proportional directional control valve VPWP.

Up to 8 modules (max. 8 axes) can be operated in parallel and independently of each other.

Commissioning via FCT (Festo configuration software) or via fieldbus:

no programming, only configuration.

Technical data → Internet: [cpx-cmax](http://cpx-cmax)

Advantages:

- Greater flexibility
- OEM friendly – commissioning also via fieldbus
- Easy installation and fast commissioning
- Cost-effective
- You program the system in your PLC environment

# Cylinders with displacement encoder

Key features

FESTO

## End-position controller CPX-CMPX



Fast travel between the mechanical end stops of the cylinder, stopping gently and without impact in the end position.  
Fast commissioning via control panel, fieldbus or handheld unit.  
Improved control of standstills.  
Control of a brake or clamping unit via the proportional directional control valve VPWP is an integral part of the controller CMPX.

Depending on the fieldbus chosen, up to 9 end-position controllers can be actuated on the CPX terminal. All system data can be read and written via the fieldbus, including, for example, the mid-positions.

Technical data → Internet: [cpx-cmpx](#)

- Advantages:
- Greater flexibility
  - OEM friendly – commissioning also via fieldbus
  - Easy installation and fast commissioning
  - Cost-effective
    - Up to 30% faster cycle rates
    - Significantly reduced system vibration
  - Improved work ergonomics thanks to significantly reduced noise level
  - The extended diagnostics help to reduce the service time of the machine

## Proportional directional control valve VPWP



The 5/3-way proportional directional control valve for applications with Soft Stop and pneumatic positioning.  
Fully digitalised – with integrated pressure sensors, with new diagnostic functions.  
In sizes 4, 6, 8 and 10.  
Flow rates of 350, 700, 1400 and 2000 l/min.

With switching output for controlling a brake.  
Coloured supply ports.  
Pre-assembled cables guarantee faultless and fast connection with the controllers CPX-CMPX and CPX-CMAX.

Technical data → Internet: [vpwp](#)

- Advantages:
- Easy installation and fast commissioning
  - Reduction of system downtimes thanks to the new diagnostic options
  - With switching output for controlling a brake/clamping unit

## Measuring module CPX-CMIX



Fully digital data acquisition and transmission means that pneumatic cylinders can be used as sensors.  
With very high repetition accuracy and incorporating both analogue and digital measuring sensors.

Suitable for the linear drive DGCI with displacement encoder for measuring absolute values, for the piston rod drive DNCI/DDPC with incremental displacement encoder or even for a potentiometer of the type MLO.

Technical data → Internet: [cpx-cmix](#)

- Advantages:
- All process steps can be documented, which improves quality
  - An adjustable contact force (via pressure regulator) increases the precision of the "displacement sensor"
  - With displacement encoders for measuring absolute values, the actual position is immediately available after the system is switched on

# Cylinders with displacement encoder

Drive options

**FESTO**

## System with linear drive DDLI, DGCI

Technical data → Internet: [ddli](#) or [dgci](#)

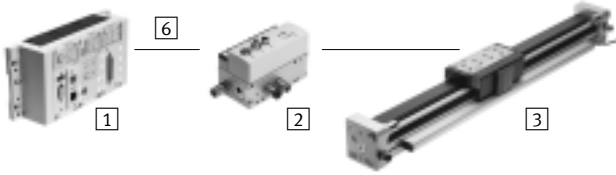

- 1 Controller module CPX-CMPX or CPX-CMAX
- 2 Proportional directional control valve VPWP
- 3 Linear drive DDLI, DGCI with displacement encoder
- 6 Connecting cable KVI-CP-3-...

- Pneumatic rodless linear drive with displacement encoder, with or without recirculating ball bearing guide
- Displacement encoder with absolute and contactless measurement
- Diameters:
  - DGCI: 18 ... 63 mm
  - DDLI: 25 ... 63 mm
- Stroke: 100 ... 2000 mm in fixed lengths
- Range of applications: Soft Stop and pneumatic positioning
- Loads from 1 ... 180 kg
- No sensor interface required

Advantages:

- Complete drive unit
- DDLI for easy connection to customer's guide system
- Excellent running characteristics
- For fast and accurate positioning up to  $\pm 0.2$  mm (only with axis controller CPX-CMAX)

## System with standard cylinder DNCI, DDPC

Technical data → Internet: [dncl](#)

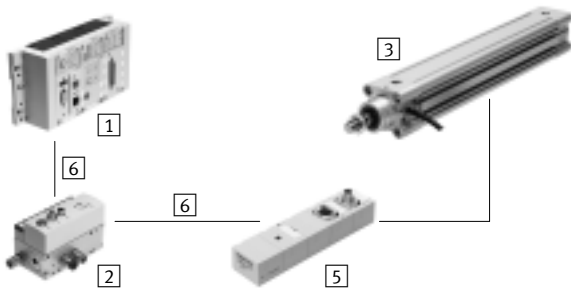

- 1 Controller module CPX-CMPX or CPX-CMAX
- 2 Proportional directional control valve VPWP
- 3 Standard cylinder DNCI, DDPC with displacement encoder
- 5 Sensor interface CASM-S-D3-R7
- 6 Connecting cable KVI-CP-3-...

- Standard cylinder with integrated displacement encoder, conforms to DIN ISO 6432, VDMA 24 562, NF E 49 003.1 and Uni 10 290
- Displacement encoder with contactless and incremental measuring
- Diameter: 32 ... 100 mm
- Stroke: 100 ... 750 mm
- Range of applications: Soft Stop and pneumatic positioning
- Loads from 3 ... 450 kg and a matching sensor interface CASM-S-D3-R7
- Pre-assembled cables guarantee faultless and fast electrical connection

Advantages:

- Compact drive unit
- Can be used universally
- Also with guide unit
- For fast and accurate positioning up to  $\pm 0.5$  mm (only with axis controller CPX-CMAX)

# Cylinders with displacement encoder

Drive options

FESTO

## System with swivel drive DSMI

Technical data → Internet: [dsmi](#)

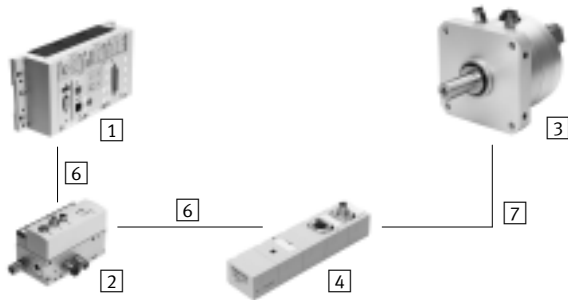

- 1 Controller module CPX-CMPX or CPX-CMAX
- 2 Proportional directional control valve VPWP
- 3 Swivel drive DSMI with displacement encoder
- 4 Sensor interface CASM-S-D2-R3
- 6 Connecting cable KVI-CP-3-...
- 7 Connecting cable NEBC-P1W4-K-0,3-N-M12G5

- Swivel drive DSMI with integrated displacement encoder
- Identical design to pneumatic swivel drive DSM
- Absolute displacement encoder based on a potentiometer
- Swivel angle of 0 ... 270°
- Size: 25, 40, 63
- Max. torque: 5 ... 40 Nm
- Range of applications: Soft Stop and pneumatic positioning
- Mass moments of inertia from 15 ... 6000 kgcm<sup>2</sup> and a matching sensor interface CASM-S-D2-R3
- Pre-assembled cables guarantee faultless and fast connection with the proportional directional control valve VPWP

Advantages:

- Complete drive unit, compact, can be used immediately
- High angular acceleration
- With adjustable fixed stops
- For fast and accurate positioning down to ±0.2° (only with axis controller CPX-CMAX)

## System with potentiometer

Technical data → Internet: [casm](#)

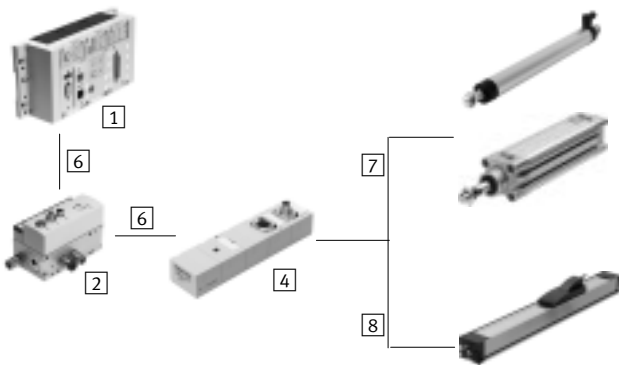

- 1 Controller module CPX-CMPX or CPX-CMAX
- 2 Proportional directional control valve VPWP
- 4 Sensor interface CASM-S-D2-R3
- 6 Connecting cable KVI-CP-3-...
- 7 Connecting cable NEBC-P1W4-K-0,3-N-M12G5
- 8 Connecting cable NEBC-A1W3-K-0,4-N-M12G5

- Attachable potentiometers with absolute measurement, with high degree of protection
- With connecting rod or moment compensator
- Measuring range:  
Connecting rod: 100 ... 750 mm  
Moment compensator: 225 ... 2000 mm
- Pre-assembled cables guarantee faultless and fast connection with the sensor interface CASM
- Range of applications: Soft Stop and pneumatic positioning with cylinder diameters of 25 ... 80 mm, e.g. DNC or DSBC
- Loads from 1 ... 300 kg

Advantages:

- Easy installation and fast commissioning
- Cost-effective
- Can also be used in harsh operating conditions
- Variety of drives: CPX-CMPX and CPX-CMAX also support cylinders with external displacement encoder

# Cylinders with displacement encoder

Drive options

System components for Soft Stop systems with end-position controller CPX-CMPX						
	Linear drive	Standard cylinder	Swivel drive	Displacement encoder		→ Page/ Internet
	DDL/DGCI	DNCI, DDPC	DSMI	MLO-LWG/-TLF	MME-MTS	
End-position controller CPX-CMPX	■	■	■	■	■	cmpx
Proportional directional control valve VPWP	■	■	■	■	■	vpwp
Sensor interface CASM-S-D2-R3	-	-	■	■	-	casm
Sensor interface CASM-S-D3-R7	-	■	-	-	-	casm
Connecting cable KVI-CP-3-...	■	■	■	■	■	kvi
Connecting cable NEBC-P1W4-...	-	-	■	■ / -	-	nebc
Connecting cable NEBC-A1W3-...	-	-	-	- / ■	-	nebc
Connecting cable NEBP-M16W6-...	-	-	-	-	■	vpwp

System components for pneumatic positioning systems with axis controller CPX-CMAX						
	Linear drive	Standard cylinder	Swivel drive	Displacement encoder		→ Page/ Internet
	DDL/DGCI	DNCI, DDPC	DSMI	MLO-LWG/-TLF	MME-MTS	
Axis controller CPX-CMAX	■	■	■	■	■	cmax
Proportional directional control valve VPWP	■	■	■	■	■	vpwp
Sensor interface CASM-S-D2-R3	-	-	■	■	-	casm
Sensor interface CASM-S-D3-R7	-	■	-	-	-	casm
Connecting cable KVI-CP-3-...	■	■	■	■	■	kvi
Connecting cable NEBC-P1W4-...	-	-	■	■ / -	-	nebc
Connecting cable NEBC-A1W3-...	-	-	-	- / ■	-	nebc
Connecting cable NEBP-M16W6-...	-	-	-	-	■	vpwp

System components for measuring cylinders with measuring module CPX-CMIX						
	Linear drive	Standard cylinder	Swivel drive	Displacement encoder		→ Page/ Internet
	DDL/DGCI	DNCI, DDPC	DSMI	MLO-LWG/-TLF	MME-MTS	
Measuring module CPX-CMIX-M1-1	■	■	■	■	■	cmix
Sensor interface CASM-S-D2-R3	-	-	■	■	-	casm
Sensor interface CASM-S-D3-R7	-	■	-	-	-	casm
Connecting cable KVI-CP-3-...	(■) <sup>1)</sup>	■	■	■	(■)	kvi
Connecting cable NEBC-P1W4-...	-	-	■	■ / -	-	nebc
Connecting cable NEBC-A1W3-...	-	-	-	- / ■	-	nebc
Connecting cable NEBP-M16W6-...	-	-	-	-	■	vpwp

1) As an extension



# Cylinders with displacement encoder

Overview

## Individual components for positioning with end-position controller SPC11

→ Internet: [spc11](#)

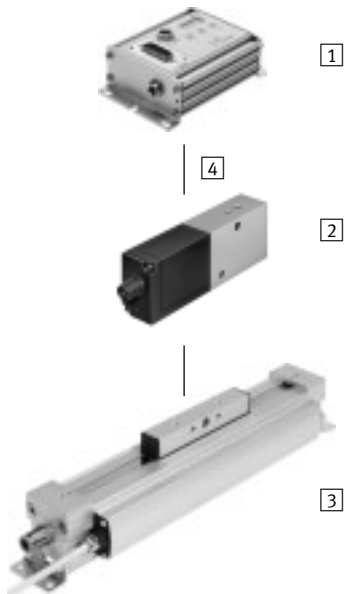

- 1 End-position controller SPC11-MTS-AIF-2
- 2 Proportional directional control valve MPYE
- 3 Linear drive DDLI
- 4 Connecting cable KMPYE-AIF...

## Individual components for use as a measuring cylinder with measuring module CPX-CMIX

→ Internet: [cmix](#)

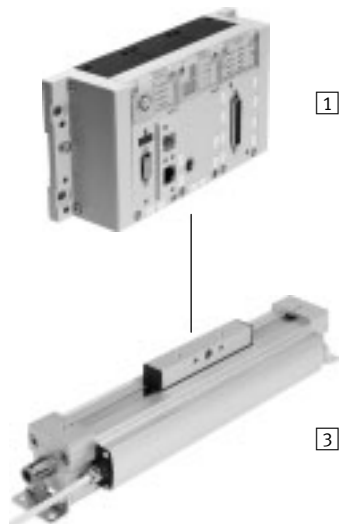

- 1 Measuring module CPX-CMIX
- 3 Linear drive DDLI

# Linear drives DDLI, with integrated displacement encoder

Peripherals overview

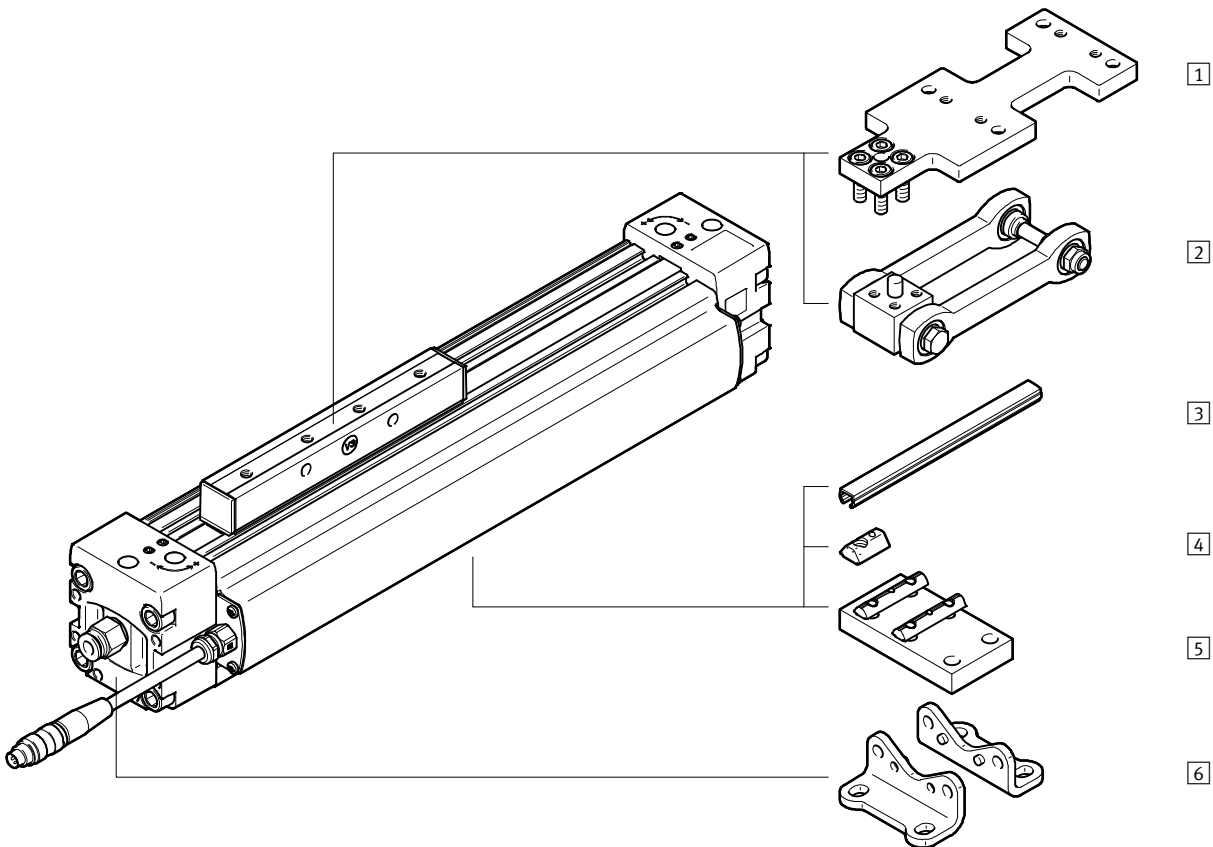

Accessories		
Type	Description	→ Page/Internet
1 Adapter plate DAMF	Has the same interface as the moment compensator FKP for the linear drive DGP	23
2 Moment compensator DARD	For compensating misalignments when using external guides	22
3 Slot cover ABP	For protecting against contamination	24
4 Slot nut ABAN/NST	For mounting attachments	24
5 Central support MUP	For mounting the axis, particularly for long stroke lengths	21
6 Foot mounting HP	For mounting the axis	21

-  - Note  
 Allocation table of drives and associated proportional directional control valves  
 → 24



# Linear drives DDLI, with integrated displacement encoder

Technical data

Function

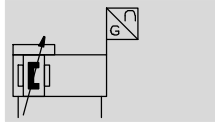

- - Diameter  
25 ... 63 mm
- - Stroke length  
100 ... 2000 mm

General technical data				
Piston∅	25	32	40	63
Design	Rodless linear drive with slide and displacement encoder			
Mode of operation	Double-acting			
Moment compensator principle	Slotted cylinder, mechanically coupled			
Mounting position	Any			
Type of mounting	Central support			
	Foot mounting			
	Direct mounting			
Cushioning	Elastic cushioning rings/pads at both ends			
Position sensing	Via integrated displacement encoder			
Measuring principle (displacement encoder)	Digital, magnetostrictive, contactless and absolute measurement			
Pneumatic connection <sup>1)</sup>	G1/8		G1/4	G3/8
Stroke <sup>2)</sup>	[mm]	100, 160, 225, 300, 360, 450, 500, 600, 750, 850, 1000, 1250, 1500, 1750, 2000		
Max. speed	[m/s]	3		

- 1) The tubing O.D. applies to pre-assembled push-in fittings → 15
- 2) Note stroke reduction in combination with CPX-CMAX

Operating and environmental conditions				
Piston∅	25	32	40	63
Operating pressure	[bar]	2 ... 8		1.5 ... 8
Operating pressure <sup>1)</sup>	[bar]	4 ... 8		
Operating medium <sup>2)</sup>	Compressed air to ISO 8573-1:2010 [6:4:4]			
Note on operating/pilot medium	Lubricated operation not possible Pressure dew point 10°C below ambient temperature/temperature of medium			
Ambient temperature	[°C]	-10 ... +60		
Vibration resistance to DIN/IEC 68 Part 2-6	At 10 ... 60 Hz: 0.15 mm			
	At 60 ... 150 Hz: 2G			
Continuous shock resistance to DIN/IEC 68 Part 2-27	Half sine 15 g, 11 ms			
CE marking (see declaration of conformity) <sup>3)</sup>	To EU EMC Directive			
Certification	C-Tick			
Corrosion resistance class CRC <sup>4)</sup>	1			

- 1) Only applies to applications with end-position controller CPX-CMPX, SPC11 and axis controller CPX-CMAX
- 2) The proportional directional control valve VPWP, MPYE used requires these characteristic values
- 3) For information about the applicability of the component see the manufacturer's EC declaration of conformity at: [www.festo.com/sp](http://www.festo.com/sp) → User documentation.  
If the component is subject to restrictions on usage in residential, office or commercial environments or small businesses, further measures to reduce the emitted interference may be necessary.
- 4) Corrosion resistance class CRC 1 to Festo standard FN 940070  
Low corrosion stress. For dry indoor applications or transport and storage protection. Also applies to parts behind covers, in the non-visible interior area, and parts which are covered in the application (e.g. drive trunnions).

# Linear drives DDLI, with integrated displacement encoder

Technical data

Forces [N] and impact energy [Nm]				
PistonØ	25	32	40	63
Theoretical force at 6 bar	295	483	754	1870
Impact energy at the end positions	0.05	0.12	0.25	0.5

Positioning characteristics with axis controller CPX-CMAX				
PistonØ	25	32	40	63
Mounting position	Any			
Resolution [mm]	0.01			
Repetition accuracy	→ 15			
Minimum load, horizontal <sup>1)</sup> [kg]	2	3	5	12
Maximum load, horizontal <sup>1)</sup> [kg]	30	50	75	180
Minimum load, vertical <sup>1)</sup> [kg]	2	3	5	12
Maximum load, vertical <sup>1)</sup> [kg]	10	15	25	60
Minimum travel speed [m/s]	0.05			
Max. travel speed [m/s]	3			
Typical positioning time, long stroke <sup>2)</sup> [s]	0.65/1.00	0.65/1.05	0.70/1.05	1.05/1.2
Typical positioning time, short stroke <sup>3)</sup> [s]	0.38/0.60	0.38/0.60	0.38/0.60	0.65/0.65
Minimum positioning stroke <sup>4)</sup> [%]	≤ 3			
Stroke reduction <sup>5)</sup> [mm]	25	25	35	35
Recommended proportional directional control valve				
For CPX-CMAX	→ 24			

- 1) Load = payload + load of all moving parts on the drive
- 2) At 6 bar, horizontal mounting position, DDLI-XX-1000, 800 mm travel at min./max. load
- 3) At 6 bar, horizontal mounting position, DDLI-XX-1000, 100 mm travel at min./max. load
- 4) In relation to the maximum stroke of the drive, but never more than 20 mm.
- 5) The stroke reduction must be maintained on each side of the drive, the max. stroke for variable positioning is thus: stroke – 2x stroke reduction

Force control characteristics with axis controller CPX-CMAX				
PistonØ	25	32	40	63
Mounting position	Any			
Maximum controllable force <sup>1)</sup> [N]	266	435	679	1683
Typical friction forces <sup>2)</sup> [N]	20	30	40	50
Repetition accuracy of pressure control <sup>3)4)</sup> [%]	< ±2			

- 1) Advancing/retracting at 6 bar
- 2) These values can fluctuate greatly from cylinder to cylinder and are not guaranteed. These friction forces must also be taken into consideration when using an external guide or when the cylinder is moving other components subject to friction
- 3) This value defines the repetition accuracy with which the internal differential pressure in the cylinder, which corresponds to the prescribed force setpoint value, is controlled and refers to the maximum controllable force
- 4) The effective force at the workpiece and its accuracy depend largely on the friction in the system as well as the repetition accuracy of the internal control system. Note that friction forces always work against the direction of movement of the piston. The following formula can be used as a rule of thumb for the force F at the workpiece:  

$$F = F_{\text{setpoint}} \pm F_{\text{friction forces}} \pm \text{repetition accuracy of pressure control}$$

# Linear drives DDLI, with integrated displacement encoder

Technical data

Positioning characteristics with Soft Stop end-position controller CPX-CMPX, SPC11					
Piston∅		25	32	40	63
Mounting position		Any			
Repetition accuracy <sup>1)</sup>	[mm]	±2			
Minimum load, horizontal <sup>2)</sup>	[kg]	2	3	5	12
Maximum load, horizontal <sup>2)</sup>	[kg]	30	50	75	180
Minimum load, vertical <sup>2)</sup>	[kg]	2	3	5	12
Maximum load, vertical <sup>2)</sup>	[kg]	10	15	25	60
Travel time		→ SoftStop engineering software: → <a href="http://www.festo.com">www.festo.com</a>			
Recommended proportional directional control valve					
For CPX-CMPX		→ 24			
For SPC11		→ 26			

- 1) One intermediate position. The accuracy in the end positions depends solely on the design of the end stops  
 2) Load = payload + load of all moving parts on the drive

Electrical data – Displacement encoder	
Output signal	Digital
Linearity error <sup>1)</sup>	[%] < ±0.02, min. ±50 µm
Max. travel speed	[m/s] 3
Degree of protection	IP67
CE marking (see declaration of conformity)	To EU EMC Directive <sup>2)</sup>
Power supply	[V DC] 24 (±25%)
Current consumption	[mA] Typically 100
Maximum temperature coefficient	[ppm/°K] 15
Electrical connection	Cable with 5-pin plug, round design, M9
Cable length	[m] 1.5
Cable quality	Suitable for use with energy chains

- 1) Always refers to max. stroke.  
 2) For information about the applicability of the component see the manufacturer's EC declaration of conformity at: [www.festo.com/sp](http://www.festo.com/sp) → User documentation.  
 If the component is subject to restrictions on usage in residential, office or commercial environments or small businesses, further measures to reduce the emitted interference may be necessary.

## Pin allocation of plug

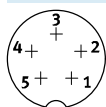

Pin	Function	Pin	Function
1	24 V	4	CAN_H
2	n.c.	5	CAN_L
3	0 V	-	Screening

# Linear drives DDLI, with integrated displacement encoder

Technical data

Weight [g]				
PistonØ	25	32	40	63
Basic weight with 0 mm stroke	1103	1716	2580	8730
Additional weight per 10 mm stroke	34	43	58	139
Moving mass	130	227	350	1669

## Materials

Sectional view

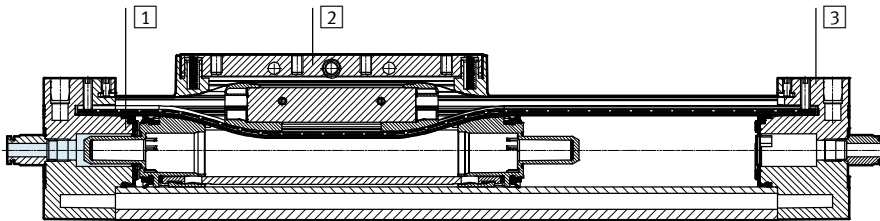

Linear drives		
1	Cylinder profile, housing	Anodised aluminium
2	Slide	Anodised aluminium
3	End cap	Painted aluminium
-	Seals	NBR, TPE-U(PU)
-	Cable	Polyurethane
-	Note on materials	Free of copper and PTFE
		RoHS-compliant

## Repetition accuracy x as a function of stroke l

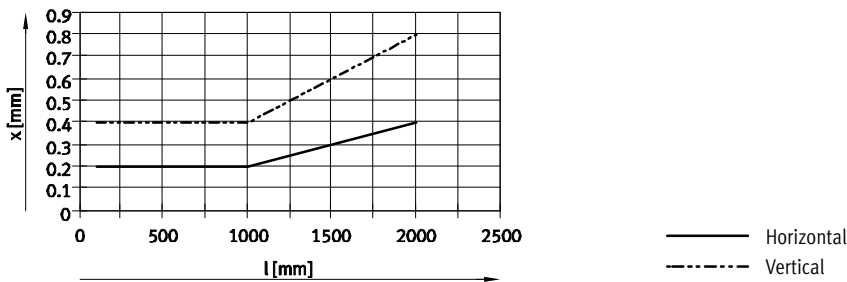

## Tubing O.D. of pre-assembled push-in fittings

Size	Stroke [mm]	Ø in [mm]			
		6	8	10	12
DDLI-25	100 ... 160	■	-	-	-
	225 ... 2000	-	■	-	-
DDLI-32	100	■	-	-	-
	160 ... 2000	-	■	-	-
DDLI-40	100 ... 750	-	■	-	-
	850 ... 2000	-	-	■	-
DDLI-63	100 ... 300	-	■	-	-
	360 ... 450	-	-	■	-
	500 ... 2000	-	-	-	■

# Linear drives DDLI, with integrated displacement encoder

Technical data

## Characteristic load values

The indicated forces and torques refer to the surface of the slide.

These values must not be exceeded during dynamic operation. Special attention must be paid to the deceleration phase.

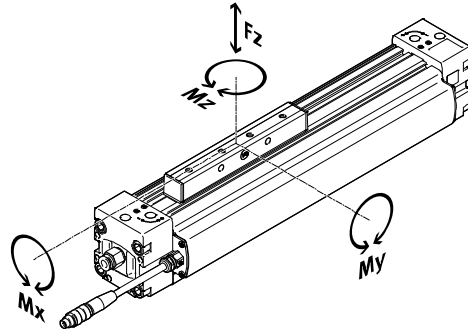

If the drive is simultaneously subjected to several of the forces and torques listed below, the following equation must be satisfied in addition to the indicated maximum loads:

$$0.4 \times \frac{Fz}{Fz_{max.}} + \frac{Mx}{Mx_{max.}} + \frac{My}{My_{max.}} + 0.2 \times \frac{Mz}{Mz_{max.}} \leq 1$$

$$\frac{Fz}{Fz_{max.}} \leq 1 \quad \frac{Mz}{Mz_{max.}} \leq 1$$

Permissible forces and torques					
Piston∅		25	32	40	63
Fz <sub>max.</sub>	[N]	330	480	800	1600
Mx <sub>max.</sub>	[Nm]	1.2	1.9	3.8	5.7
My <sub>max.</sub>	[Nm]	20	40	60	150
Mz <sub>max.</sub>	[Nm]	3	5	8	24



# Linear drives DDLI, with integrated displacement encoder

Technical data

## Number of central supports MUP as a function of overall length

Excessive distances between the central supports can reduce the positioning accuracy. The following table shows the required minimum number of central supports and foot mountings.

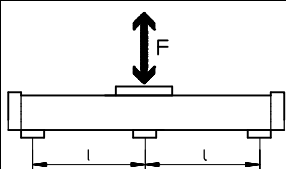
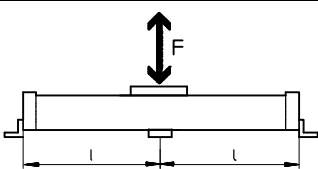
Stroke [mm]	Number of mounting components			
	Order code MA		Order code MF	
	Central support	Foot mounting	+ Central support	
				
100 ... 400	2	2	0	
401 ... 600	2	2	1	
601 ... 1200	3	2	1	
1201 ... 1400	3	2	2	
1401 ... 2000	4	2	2	

# Linear drives DDLI, with integrated displacement encoder

Technical data

Dimensions Download CAD data → [www.festo.com](http://www.festo.com)

+ = plus stroke length  
 1 Mounting hole for foot mounting  
 2 Connecting thread  
 3 Cable length 1500 mm

∅	B1	B3	B4	B5	B6	B7	B11	D2
[mm]	±0.4	±0.2				+0.4		∅
25	45	19	39.1	18	32.5	60.2	9.5	3.3
32	54	19	46	21	40	69.1	9.5	4.3
40	64	21	53	28	49	78.4	9.6	4.3
63	106	24	89	44	83	110.9	21.1	6.3

∅	D3	D4	D5	D6	EE	H1	H2	H3
[mm]	∅ ±0.2		∅ H7					
25	5.2	M5	8	M4	G1/8	63	57	51
32	5.2	M5	8	M5	G1/8	72	66	61.8
40	6.5	M6	10	M5	G1/4	86	78	71.8
63	8.5	M8	12	M8	G3/8	131	122	115.2

∅	H4	H5	H6	H7	H8	R1	L1	L2
[mm]								
25	19.55	22.5	34.5	5.15	28.7	2.5	200	100
32	23	27	34.5	12.65	30.4	3.5	250	125
40	26.5	32	34.5	16.25	35.5	5	300	150
63	44.5	53	34.5	43.25	61	2	400	200

# Linear drives DDLI, with integrated displacement encoder

Technical data

∅	L5	L6	L7	L8	L9	T1	T2	T3
[mm]			±0.1	±0.1	±0.1			
25	25	109	30	50	–	13	2	7.5
32	31	135	50	100	30	13.2	3	7.5
40	31	171	70	130	40	13.2	3	7.5
63	34	234	110	190	70	21.2	6	12.5

∅	Stroke	D7	E	L3	L4
[mm]	[mm]				
25	100 ... 160	6	15	15.9	16.4
	225 ... 2000	8	16	21.1	21.6
32	100	6	15	15.9	16.4
	160 ... 2000	8	16	21.1	21.6
40	100 ... 750	8	19	16.6	17.2
	850 ... 2000	10	19	23.6	24.3
63	100 ... 300	8	22	15.8	16.3
	360 ... 500	10	22	19.6	20.2
	600 ... 2000	12	24	25.7	26.3

## Profile barrel

∅ 25

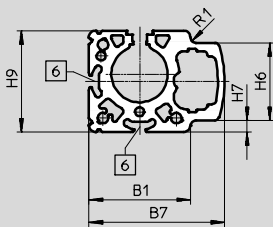

∅ 32

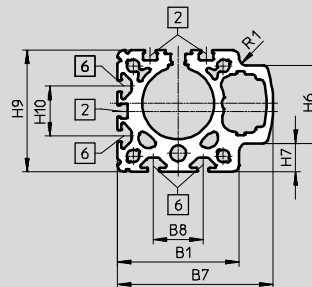

∅ 40

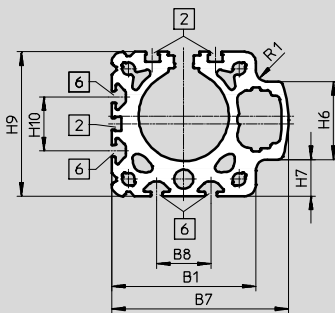

∅ 63

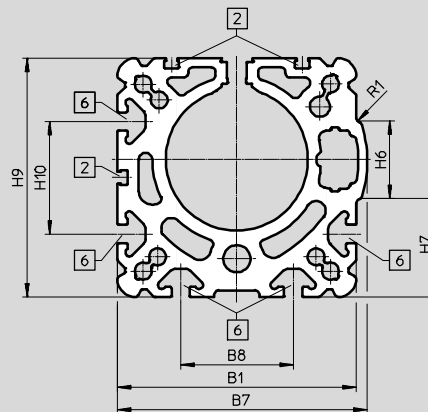

- 2 Sensor slot
- 6 Mounting slot for slot nut

∅	B1	B7	B8	H6	H7	H9	H10	R1
[mm]	+0.4	+0.4				+0.4		
25	45	60.2	–	34.5	5.15	45	–	2.5
32	54	69.1	22	34.5	12.65	54	22	3.5
40	64	78.4	24	34.5	16.25	64	24	5
63	106	110.9	50	34.5	43.3	106	50	2

# Linear drives DDLI, with integrated displacement encoder



Ordering data – Modular products

Ordering table							
Piston∅	25	32	40	63	Condi- tions	Code	Entry code
<b>M</b> Module No.	<b>1315779</b>	<b>1344778</b>	<b>1463452</b>	<b>1572299</b>			
Function	Linear drive with integrated displacement encoder					<b>DDLI</b>	DDLI
Piston∅ [mm]	25	32	40	63		-...	
Stroke [mm]	100, 160, 225, 300, 360, 450, 500, 600, 750, 850, 1000, 1250, 1500, 1750, 2000					-...	
Cushioning	Elastic cushioning rings/pads at both ends					<b>-P</b>	-P
<b>O</b> Lubrication	Standard						
	Lubrication approved for use in food applications					<b>-H1</b>	
Foot mounting	None						
	1 set					<b>-MF</b>	
Profile mounting	None						
	1 ... 10					<b>...MA</b>	
Sensor slot cover	None						
	-	1 set (for the entire drive length and all slots)				<b>NS</b>	
Mounting slot cover	None						
	1 set (for the entire drive length and all slots)					<b>NC</b>	
Slot nut for mounting slot	None						
	1 ... 50				<b>1</b>	<b>...NM</b>	
Moment compensator	None						
	With moment compensator					<b>T</b>	
Adapter plate	None						
	FKP interface				<b>2</b>	<b>AP</b>	
Operating instructions	With operating instructions						
	Without operating instructions					<b>DN</b>	

**1 NM** For size 25: Entry "1NM" = delivery quantity 4 pieces

**2 AP** Only with moment compensator T

### Transfer order code

**DDLI** -  -  - **P** -  -

# Linear drives DDLI, with integrated displacement encoder

Accessories

**Foot mounting HP**  
(Order code: MF)

Material:  
Galvanised steel

Free of copper and PTFE

 Note  
Central supports MUP are additionally required for strokes above 400 mm → 17

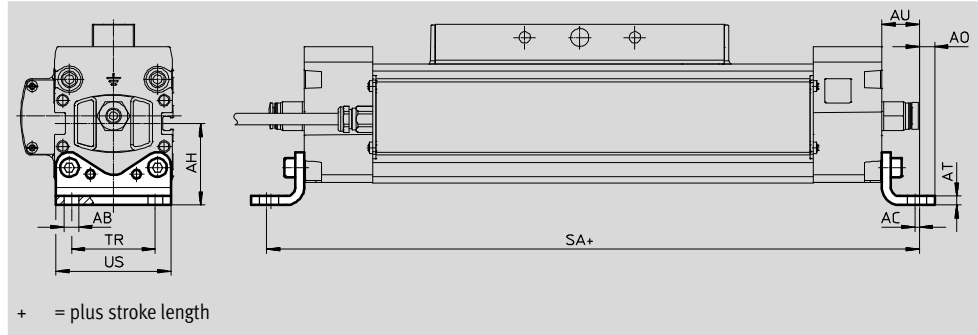

Dimensions and ordering data												
For Ø	AB	AC	AH	AO	AT	AU	SA	TR	US	Weight	Part No.	Type
[mm]	Ø									[g]		
25	5.5	2	29.5	6	3	13	226	32.5	44	61	150731	HP-25
32	6.6	2	37	7	4	17	284	38	52	117	150732	HP-32
40	6.6	2	46	8.5	5	17.5	335	45	62	188	150733	HP-40
63	11	3	69	13.5	6	28	456	75	102	305	150735	HP-63

**Central support MUP**  
(Order code: MA)

Material:  
Anodised aluminium

Free of copper and PTFE

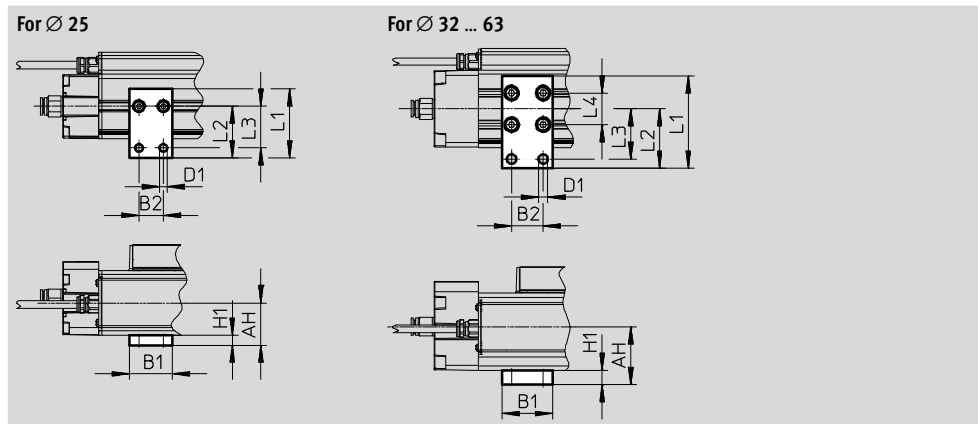

Dimensions and ordering data												
For Ø	AH	B1	B2	D1	H1	L1	L2	L3	L4	Weight	Part No.	Type
[mm]				Ø						[g]		
25	29.5	30	17	5.5	7	48	36	29	–	33	1711704	MUP-18/25-P
32	37	35	22	6.6	10	64.5	41.5	35	22	89	150737	MUP-32
40	46	35	22	6.6	14	75	47	40	24	126	150738	MUP-40
63	69	50	26	11	16	125	77	65	50	340	150800	MUP-63

# Linear drives DDLI, with integrated displacement encoder



Accessories

**Moment compensator DARD**  
(Order code: T)

Material:  
Galvanised steel

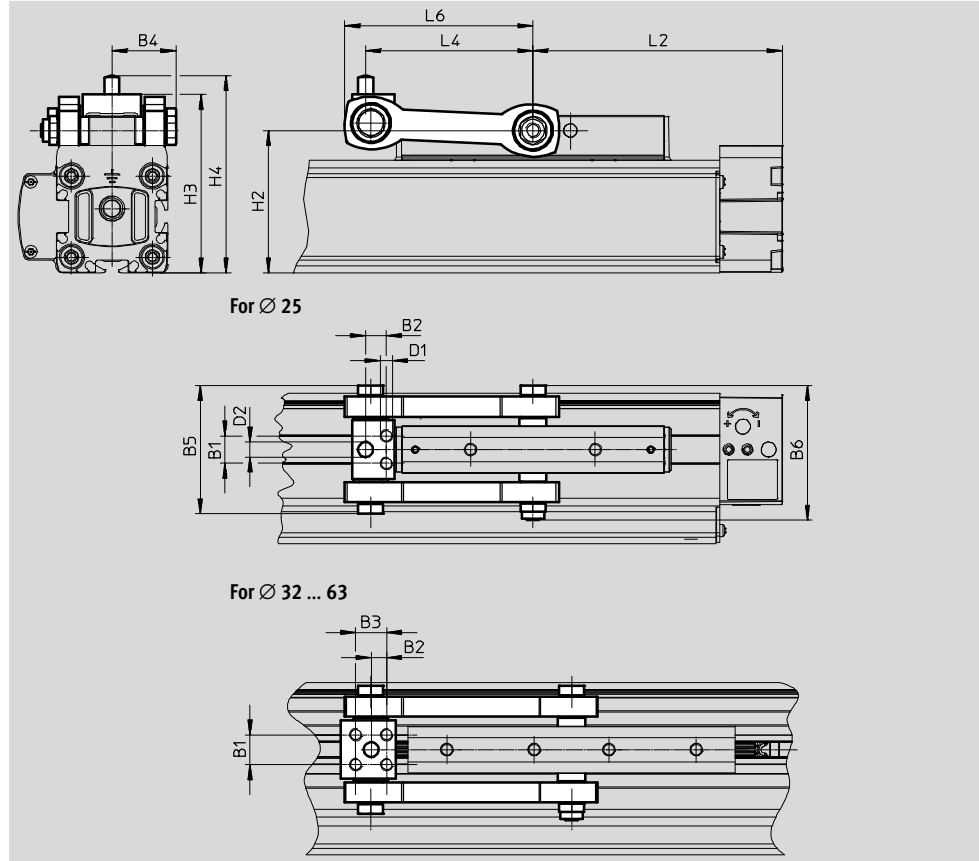

Dimensions and ordering data				
For $\varnothing$ [mm]	Max. offset between linear drive and external guide <sup>1)</sup> [mm]	Max. permissible load in direction of force [N]	Ambient temperature [°C]	Weight [g]
25	$\pm 2.5$	800	-10 ... +60	240
32	$\pm 2.5$	1300	-10 ... +60	275
40	$\pm 2.5$	2000	-10 ... +60	580
63	$\pm 4$	5000	-10 ... +60	1000

1) Laterally and vertically.

For $\varnothing$ [mm]	B1	B2	B3	B4	B5	B6	D1 $\varnothing$	D2 $\varnothing$	H2
25	11	8.4	-	$25.7 \pm 2.5$	51.4	54	M5x17	6	57
32	12	6.2	12.4	$25.7 \pm 2.5$	51.4	54	M5x13	6	66
40	18	11	17	$36 \pm 2.5$	72	75.3	M6x16	6	78
63	26	12.6	19	$44 \pm 4$	88	96.4	M8x18	10	122

For $\varnothing$ [mm]	H3	H4	L2	L4	L6 max.	Part No.	Type
25	$71.5 \pm 2.5$	$79 \pm 2.5$	100	67.1	75.5	<b>2349275</b>	<b>DARD-L1-25-M</b>
32	$80.5 \pm 2.5$	$88 \pm 2.5$	125	80.3	91	<b>2349276</b>	<b>DARD-L1-32-M</b>
40	$94.5 \pm 2.5$	$104.5 \pm 2.5$	150	104	117	<b>2349277</b>	<b>DARD-L1-40-M</b>
63	$142 \pm 4$	$152 \pm 4$	200	138	153	<b>2349279</b>	<b>DARD-L1-63-M</b>

# Linear drives DDLI, with integrated displacement encoder

Accessories

**Adapter plate DAMF**  
(Order code: AP)

Material:  
Galvanised steel

The adapter plate DAMF has the same interface as the moment compensator FKP for linear drive DGP.

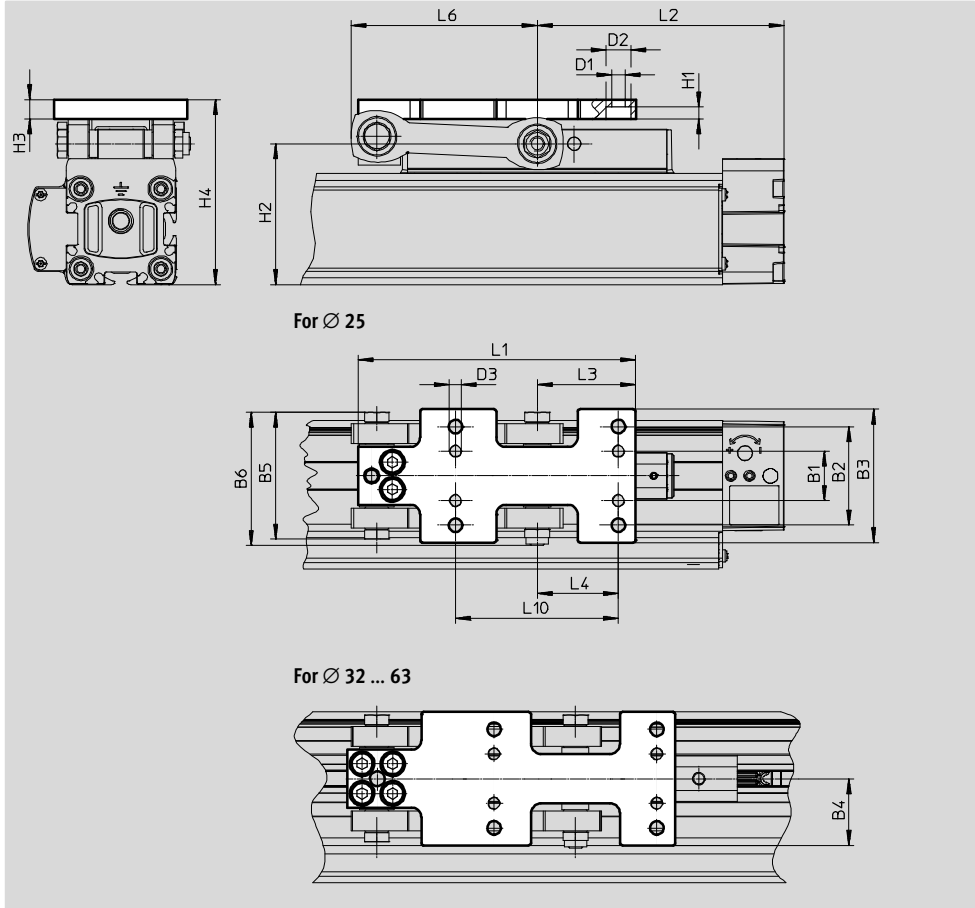



Dimensions and ordering data												
For $\varnothing$	B1	B2	B3	B4	B5	B6	D1	D2	D3	H1	H2	H3
[mm]							$\varnothing$	$\varnothing$				
25	20	40	54	27 $\pm$ 2.5	51.4	54	5.5	10	M5	5	57	8
32	20	40	54	27 $\pm$ 2.5	51.4	54	5.5	10	M5	5	66	8
40	24	44	58	29 $\pm$ 2.5	72	75.3	6.6	11	M6	6	78	10
63	23	51	71	35.5 $\pm$ 4	88.1	96.4	9	15	M8	8	122	10

For $\varnothing$	H4	L1	L2	L3	L4	L6	L10	Weight	Part No.	Type
[mm]						max.				
25	75 $\pm$ 2.5	112.4	100	40	33	75.5	66	265	<b>2349282</b>	<b>DAMF-25-FKP</b>
32	84 $\pm$ 2.5	133	125	40.5	33	91	66	308	<b>2349283</b>	<b>DAMF-32-FKP</b>
40	99 $\pm$ 2.5	162	150	45	38	117	76	593	<b>2349284</b>	<b>DAMF-40-FKP</b>
63	146 $\pm$ 4	214	200	61	51	153	102	1042	<b>2349286</b>	<b>DAMF-63-FKP</b>

# Linear drives DDLI, with integrated displacement encoder

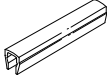

Accessories

Ordering data						
	For Ø	Description	Order code	Part No.	Type	PU <sup>1)</sup>
Slot nut ABAN, NST <span style="float: right;">Technical data → Internet: hmbn</span>						
	25	For mounting slot	NM	<b>8003032</b>	<b>ABAN-1M4-5</b>	4
	32, 40			<b>150914</b>	<b>NST-5-M5</b>	1
	63			<b>150915</b>	<b>NST-8-M6</b>	
Slot cover ABP <span style="float: right;">Technical data → Internet: abp</span>						
	25	For mounting slot	NC	<b>563360</b>	<b>ABP-5-S1</b>	2
	32, 40	Every 0.5 m		<b>151681</b>	<b>ABP-5</b>	
	63			<b>151682</b>	<b>ABP-8</b>	
	25, 32, 40, 63	For sensor slot Every 0.5 m	NS	<b>563360</b>	<b>ABP-5-S1</b>	2

1) Packaging unit

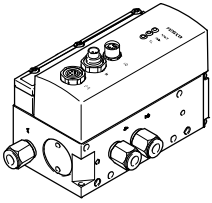
Ordering data – Proportional directional control valves						
	For Ø	Stroke	Proportional directional control valve			
	[mm]	[mm]	Technical data → Internet: vpw			
			Part No.	Type		
	For applications with axis controller CPX-CMAX					
	25	100 ... 160	<b>550170</b>	<b>VPWP-4-L-5-Q6-10-E-...</b>		
		225 ... 600	<b>550170</b>	<b>VPWP-4-L-5-Q8-10-E-...</b>		
		750 ... 2000	<b>550171</b>	<b>VPWP-6-L-5-Q8-10-E-...</b>		
	32	100	<b>550170</b>	<b>VPWP-4-L-5-Q6-10-E-...</b>		
		160 ... 360	<b>550170</b>	<b>VPWP-4-L-5-Q8-10-E-...</b>		
		450 ... 2000	<b>550171</b>	<b>VPWP-6-L-5-Q8-10-E-...</b>		
	40	100 ... 300	<b>550170</b>	<b>VPWP-4-L-5-Q8-10-E-...</b>		
		360 ... 750	<b>550171</b>	<b>VPWP-6-L-5-Q8-10-E-...</b>		
		850 ... 2000	<b>550172</b>	<b>VPWP-8-L-5-Q10-10-E-...</b>		
	63	100 ... 300	<b>550171</b>	<b>VPWP-6-L-5-Q8-10-E-...</b>		
		360 ... 450	<b>550172</b>	<b>VPWP-8-L-5-Q10-10-E-...</b>		
		500 ... 750	<b>550172</b>	<b>VPWP-8-L-5-Q-10-E-...<sup>1)</sup></b>		
		850 ... 2000	<b>1552544</b>	<b>VPWP-10-L-5-Q-10-E-G-EX1<sup>1)</sup></b>		

1) Push-in fittings for a tubing O.D. of 12 mm must be used for these stroke ranges.



# Linear drives DDLI, with integrated displacement encoder

Accessories

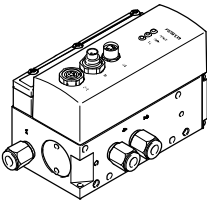
Ordering data – Proportional directional control valves				
	For Ø	Stroke	Proportional directional control valve	
	[mm]	[mm]	Technical data → Internet: vpw Part No. Type	
	For applications with Soft Stop end-position controller CPX-CMPX, horizontal			
	25	100 ... 160	550170	VPWP-4-L-5-Q6-10-E-...
		225 ... 300	550170	VPWP-4-L-5-Q8-10-E-...
		360 ... 2000	550171	VPWP-6-L-5-Q8-10-E-...
	32	100	550170	VPWP-4-L-5-Q6-10-E-...
		160 ... 1000	550171	VPWP-6-L-5-Q8-10-E-...
		1250 ... 2000	550172	VPWP-8-L-5-Q-10-E-... <sup>1)</sup>
	40	100 ... 500	550171	VPWP-6-L-5-Q8-10-E-...
		600 ... 750	550172	VPWP-8-L-5-Q-10-E-... <sup>1)</sup>
		850 ... 2000	550172	VPWP-8-L-5-Q10-10-E-...
	63	100 ... 300	550171	VPWP-6-L-5-Q8-10-E-...
		360 ... 400	550172	VPWP-8-L-5-Q10-10-E-...
		450	1552544	VPWP-10-L-5-Q-10-E-G-EX1 <sup>2)</sup>
		500 ... 2000	1552544	VPWP-10-L-5-Q-10-E-G-EX1 <sup>3)</sup>

- 1) Push-in fittings for a tubing O.D. of 8 mm must be used for these stroke ranges.
- 2) Push-in fittings for a tubing O.D. of 10 mm must be used for this stroke range.
- 3) Push-in fittings for a tubing O.D. of 12 mm must be used for these stroke ranges.

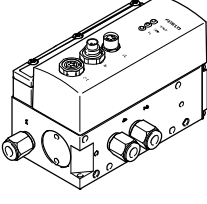
Ordering data – Proportional directional control valves				
	For Ø	Stroke	Proportional directional control valve	
	[mm]	[mm]	Technical data → Internet: vpw Part No. Type	
	For applications with Soft Stop end-position controller CPX-CMPX, vertical			
	25	100 ... 160	550170	VPWP-4-L-5-Q6-10-E-...
		225 ... 750	550170	VPWP-4-L-5-Q8-10-E-...
		850 ... 2000	550171	VPWP-6-L-5-Q8-10-E-...
	32	100	550170	VPWP-4-L-5-Q6-10-E-...
		160 ... 300	550170	VPWP-4-L-5-Q8-10-E-...
		360 ... 1750	550171	VPWP-6-L-5-Q8-10-E-...
		2000	550172	VPWP-8-L-5-Q-10-E-... <sup>1)</sup>
	40	100 ... 225	550170	VPWP-4-L-5-Q8-10-E-...
		300 ... 750	550171	VPWP-6-L-5-Q8-10-E-...
		850 ... 1000	550171	VPWP-6-L-5-Q-10-E-... <sup>2)</sup>
		1250 ... 2000	550172	VPWP-8-L-5-Q10-10-E-...
	63	100 ... 225	550170	VPWP-4-L-5-Q8-10-E-...
		300	550171	VPWP-6-L-5-Q8-10-E-...
		360 ... 450	550172	VPWP-8-L-5-Q10-10-E-...
500 ... 2000		1552544	VPWP-10-L-5-Q-10-E-G-EX1 <sup>3)</sup>	

- 1) Push-in fittings for a tubing O.D. of 8 mm must be used for these stroke ranges.
- 2) Push-in fittings for a tubing O.D. of 10 mm must be used for these stroke ranges.
- 3) Push-in fittings for a tubing O.D. of 12 mm must be used for these stroke ranges.

# Linear drives DDLI, with integrated displacement encoder

Accessories

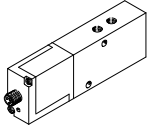
Ordering data – Proportional directional control valves				
	For Ø	Stroke	Proportional directional control valve	
	[mm]	[mm]	Technical data → Internet: mpye	Part No. Type
	For applications with Soft Stop end-position controller SPC11-MTS-AIF-2, horizontal			
	25	100 ... 160	151692	MPYE-5-1/8-LF-010-B
		225 ... 300	151692	MPYE-5-1/8-LF-010-B
		360 ... 2000	151693	MPYE-5-1/8-HF-010-B
	32	100	151692	MPYE-5-1/8-LF-010-B
		160 ... 1000	151693	MPYE-5-1/8-HF-010-B
		1250 ... 2000	151694	MPYE-5-1/4-010-B
	40	100 ... 500	151693	MPYE-5-1/8-HF-010-B
		600 ... 750	151694	MPYE-5-1/4-010-B
		850 ... 2000	151694	MPYE-5-1/4-010-B
	63	100 ... 300	151693	MPYE-5-1/8-HF-010-B
		360 ... 400	151694	MPYE-5-1/4-010-B
450 ... 2000		151695	MPYE-5-3/8-010-B	

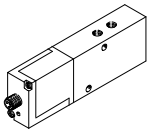
Ordering data – Proportional directional control valves				
	For Ø	Stroke	Proportional directional control valve	
	[mm]	[mm]	Technical data → Internet: mpye	Part No. Type
	For applications with Soft Stop end-position controller SPC11-MTS-AIF-2, vertical			
	25	100 ... 160	151692	MPYE-5-1/8-LF-010-B
		225 ... 750	151692	MPYE-5-1/8-LF-010-B
		850 ... 2000	151693	MPYE-5-1/8-HF-010-B
	32	100	151692	MPYE-5-1/8-LF-010-B
		160 ... 300	151692	MPYE-5-1/8-LF-010-B
		360 ... 1750	151693	MPYE-5-1/8-HF-010-B
		2000	151694	MPYE-5-1/4-010-B
	40	100 ... 225	151692	MPYE-5-1/8-LF-010-B
		300 ... 750	151693	MPYE-5-1/8-HF-010-B
		850 ... 1000	151693	MPYE-5-1/8-HF-010-B
		1250 ... 2000	151694	MPYE-5-1/4-010-B
	63	100 ... 225	151692	MPYE-5-1/8-LF-010-B
		300	151693	MPYE-5-1/8-HF-010-B
		360 ... 450	151694	MPYE-5-1/4-010-B
	500 ... 2000	151695	MPYE-5-3/8-010-B	

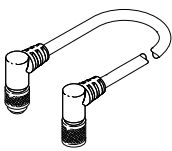
Ordering data – Connecting cables				
	Description	Cable length [m]	Part No.	Type
Connection between axis controller CPX-CMAX/end-position controller CPX-CMPX and proportional directional control valve VPWP				
	Angled plug and angled socket	0.25	540327	KVI-CP-3-WS-WD-0,25
		0.5	540328	KVI-CP-3-WS-WD-0,5
		2	540329	KVI-CP-3-WS-WD-2
		5	540330	KVI-CP-3-WS-WD-5
		8	540331	KVI-CP-3-WS-WD-8
	Straight plug and straight socket	2	540332	KVI-CP-3-GS-GD-2
		5	540333	KVI-CP-3-GS-GD-5
		8	540334	KVI-CP-3-GS-GD-8