

**Non-return valves VBNF**





# Non-return valves VBNF

Key features and product range overview

## Features

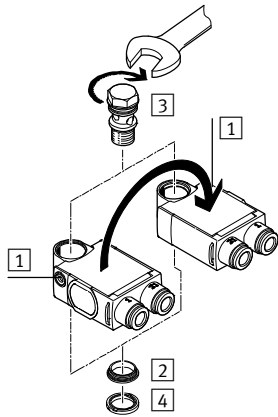



- Minimal height
- High flow rate
- Can be rotated horizontally through 360° in assembled state
- Actuation direction **1** can be changed by repositioning the housing

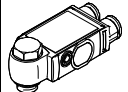

 Note

The following sequence must be observed when assembling the individual components:

- 1) Press thrust ring **2** into the housing until it fits tightly.
- 2) Insert hollow bolt **3** into the opening.
- 3) Push sealing ring **4** over the thread of the hollow bolt.

Product range overview							
Function	Valve function	Design	Type	Pneumatic connection 1	Pneumatic connection 2	qnN [l/min]	→ Page/Internet
Non-return valves	<b>Flat design</b>						
	Piloted non-return function		VBNF	QS-6, QS-8	G <sup>1</sup> / <sub>8</sub> , G <sup>1</sup> / <sub>4</sub>	260 ... 620	3
	<b>Compact design</b>						
	Non-return function		H	QS-4, QS-6, QS-8, QS-10, QS-12	QS-4, QS-6, QS-8, QS-10, QS-12	136 ... 1,715	h-qs
				M5, G <sup>1</sup> / <sub>8</sub> , G <sup>1</sup> / <sub>4</sub> , G <sup>3</sup> / <sub>8</sub> , G <sup>1</sup> / <sub>2</sub> , G <sup>3</sup> / <sub>4</sub>	M5, G <sup>1</sup> / <sub>8</sub> , G <sup>1</sup> / <sub>4</sub> , G <sup>3</sup> / <sub>8</sub> , G <sup>1</sup> / <sub>2</sub> , G <sup>3</sup> / <sub>4</sub>	115 ... 5,900	h
	Non-return function		HA	M5, R <sup>1</sup> / <sub>8</sub> , R <sup>1</sup> / <sub>4</sub> , R <sup>3</sup> / <sub>8</sub> , R <sup>1</sup> / <sub>2</sub>	QS-4, QS-6, QS-8, QS-10, QS-12	138 ... 2,230	ha
			HB	QS-4, QS-6, QS-8, QS-10, QS-12	M5, R <sup>1</sup> / <sub>8</sub> , R <sup>1</sup> / <sub>4</sub> , R <sup>3</sup> / <sub>8</sub> , R <sup>1</sup> / <sub>2</sub>	142 ... 2,206	hb
	Piloted non-return function		HGL	QS-4, QS-6, QS-8, QS-10, QS-12	M5, G <sup>1</sup> / <sub>8</sub> , G <sup>1</sup> / <sub>4</sub> , G <sup>3</sup> / <sub>8</sub> , G <sup>1</sup> / <sub>2</sub>	130 ... 1,400	hgl
				M5, G <sup>1</sup> / <sub>8</sub> , G <sup>1</sup> / <sub>4</sub> , G <sup>3</sup> / <sub>8</sub> , G <sup>1</sup> / <sub>2</sub>	M5, G <sup>1</sup> / <sub>8</sub> , G <sup>1</sup> / <sub>4</sub> , G <sup>3</sup> / <sub>8</sub> , G <sup>1</sup> / <sub>2</sub>	130 ... 1,600	hgl

# Non-return valves VBNF

Type codes



		VBNF	-	L	BA	-	G18	-	Q6
<b>Type</b>									
VBNF	Non-return valve, flat design								
<b>Design</b>									
L	L-shaped outlet								
<b>Additional function</b>									
BA	Piloted non-return function, manual exhaust function								
<b>Pneumatic connection 2</b>									
G18	Thread G $\frac{1}{8}$								
G14	Thread G $\frac{1}{4}$								
<b>Pneumatic connection 1</b>									
Q6	Push-in connector QS-6								
Q8	Push-in connector QS-8								

## Non-return valves VBNF

Technical data

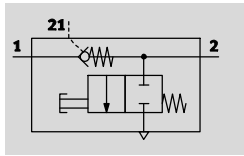
Piloted non-return function



-  - Standard nominal flow rate  
260 ... 620 l/min
-  - Temperature range  
-10 ... +60 °C
-  - Operating pressure  
0.2 ... 10 bar



The non-return valve VBNF-LBA is a valve with a piloted non-return function and a manual exhaust function. The piloted non-return function can be

used for a temporary intermediate stop. If a pilot signal is applied, the exhaust air can escape. If no pilot

signal is applied, the valve shuts off the exhaust air from the drive and the drive stops temporarily.

The integrated manual exhaust function can be used to manually vent a pneumatic drive.

General technical data		
Valve function	Piloted non-return function	
Pneumatic connection 2	G $\frac{1}{8}$	G $\frac{1}{4}$
Pneumatic connection 1	QS-6	QS-8
Pilot air connection 21	QS-6	QS-8
Type of actuation, piloted non-return function	Pneumatic	
Manual exhaust function	Non-detenting	
Type of mounting	Screw-in	
Mounting position	Any	
Switching time	Off [ms]	9
	On [ms]	6
Nominal tightening torque	[Nm]	3 ±20%
		11 ±20%
Rotatability	[°]	360 (continuous rotation not permitted)

Operating and environmental conditions		
Operating pressure for entire temperature range	[bar]	0.2 ... 10
Pilot pressure	[bar]	2 ... 10
Operating/pilot medium		Compressed air according to ISO 8573-1:2010 [7:4:4]
Note on operating/pilot medium		Lubricated operation possible (in which case lubricated operation will always be required)
Ambient temperature	[°C]	-10 ... +60
Temperature of medium	[°C]	-10 ... +60
Storage temperature	[°C]	-20 ... +70
Corrosion resistance class CRC <sup>1)</sup>		2

1) Corrosion resistance class CRC 2 to Festo standard FN 940070  
Moderate corrosion stress. Indoor applications in which condensation may occur. External visible parts with primarily decorative requirements for the surface and which are in direct contact with the ambient atmosphere typical for industrial applications.

### Materials

Sectional view

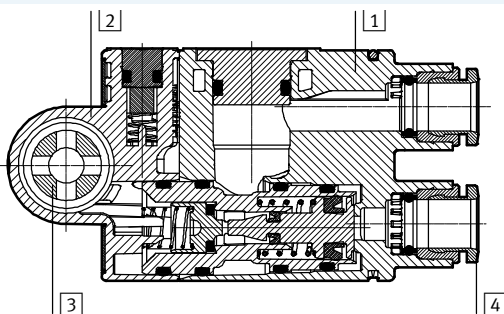

Non-return valve		
1	Housing	PBT
2	End cap	PBT
3	Hollow bolt	Wrought aluminium alloy
4	Releasing ring	POM
-	Cover	ES-BE
-	Seals	NBR
Note on materials		RoHS-compliant

# Non-return valves VBNF

Technical data

Minimum pilot pressure p21 as a function of operating pressure p1



## Dimensions

Download CAD data → [www.festo.com](http://www.festo.com)

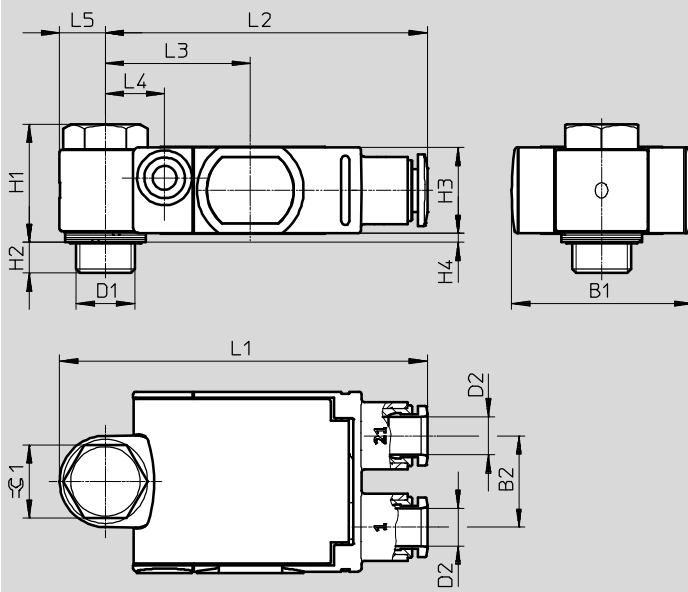

Type	Connection D1	Tubing O.D. D2	B1	B2	H1	H2	H3	H4	L1	L2	L3	L4	L5	≈C1
VBNF-...-G18-Q6	G1/8	QS-6	29.8	15	19.4	5	14.1	1.5	60.3	52.8	23.8	9.7	7.5	12
VBNF-...-G14-Q8	G1/4	QS-8	39.5	20.5	28.2	5.6	21	2	76.8	66.8	30	11.1	10	15

## Ordering data

Design	Pneumatic connection		Pilot air connection	Standard nominal flow rate qnN at 6 bar → 5 bar	Standard flow rate qN at 6 bar → 0 bar	Weight	Part No.	Type
	2	1	21	[l/min]	[l/min]	[g]		
	G1/8	QS-6	QS-6	260	500	27.3	<b>8001460</b>	<b>VBNF-LBA-G18-Q6</b>
	G1/4	QS-8	QS-8	620	1,100	65.5	<b>1927027</b>	<b>VBNF-LBA-G14-Q8</b>