

Passive guide axes FDG, without drive



Do not use for new designs!

- T - Type discontinued

Passive guide axes FDG, without drive

Key features

FESTO

At a glance

- Driveless linear guide unit with guide and freely movable slide
- The passive guide axis is designed to increase force and torque capacities in multi-axis applications
- Higher torsional resistance
- Reduced vibrations with dynamic loads
- Drive axis and passive guide axis can be arranged adjacent to or above one another

System product for handling and assembly technology

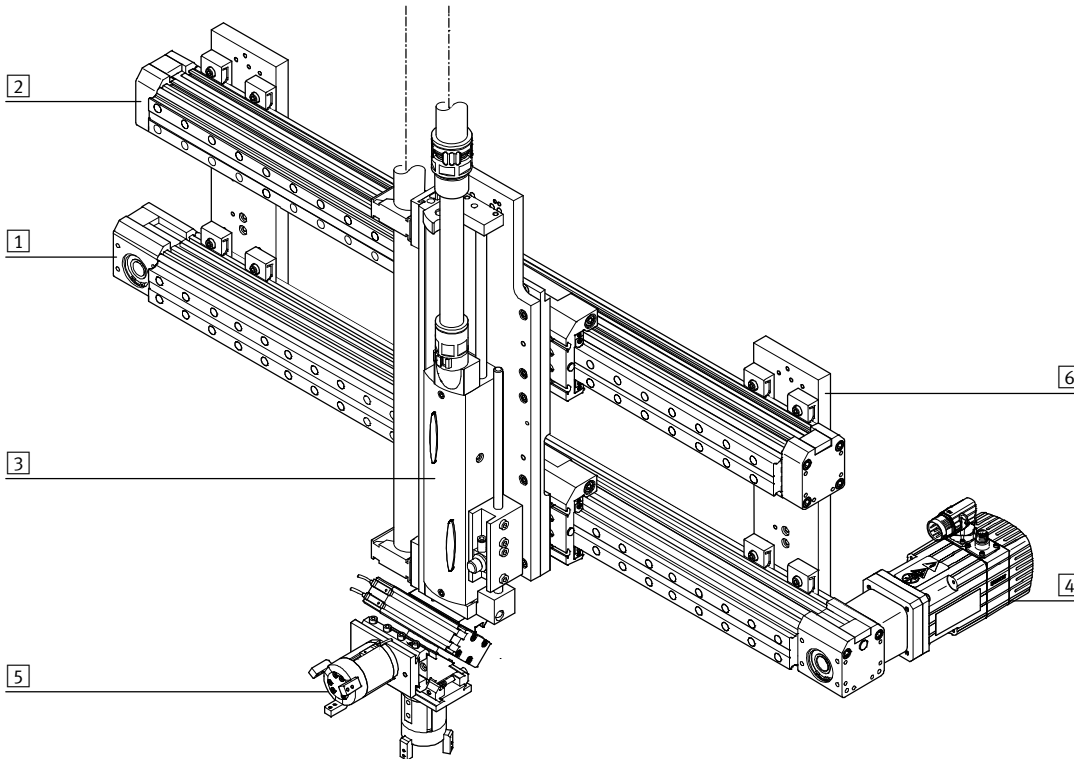

System components and accessories

	Brief description	→ Page/Internet
1	Axes	axis
2	Passive guide axes	guide axis
3	Drives	drive
4	Motors	motor
5	Grippers	gripper
6	Adapters	adapter kit

Do not use for new designs!

- 7 - Type discontinued

FESTO

Passive guide axes FDG, without drive

Key features

Guide axes and the corresponding drives

Passive guide axis DGC-FA



- Can be combined with:
 - Linear drive DGC-KF
- For size 8 ... 63
- Load capacity to max. 6,890 N or 380 Nm

Passive guide axis EGC-FA



- Can be combined with:
 - Toothed belt axis EGC-TB
 - Spindle axis EGC-BS
- For size 70 ... 185
- Load capacity to max. 15,200 N or 1,820 Nm

Passive guide axis FDG-ZR-RF



- Can be combined with:
 - Toothed belt axis DGE-ZR-RF
- For size 25 ... 63
- Load capacity to max. 1,500 N or 600 Nm

Passive guide axis FDG-P/-ZR/-SP



- Can be combined with:
 - Linear drive DGPL
 - Toothed belt axis DGE-ZR-KF
 - Spindle axis DGE-SP-KF
- For size 18 ... 63
- Load capacity to max. 14,050 N or 1,820 Nm

Do not use for new designs!

- T - Type discontinued

Passive guide axes FDG, without drive

Peripherals overview

FESTO

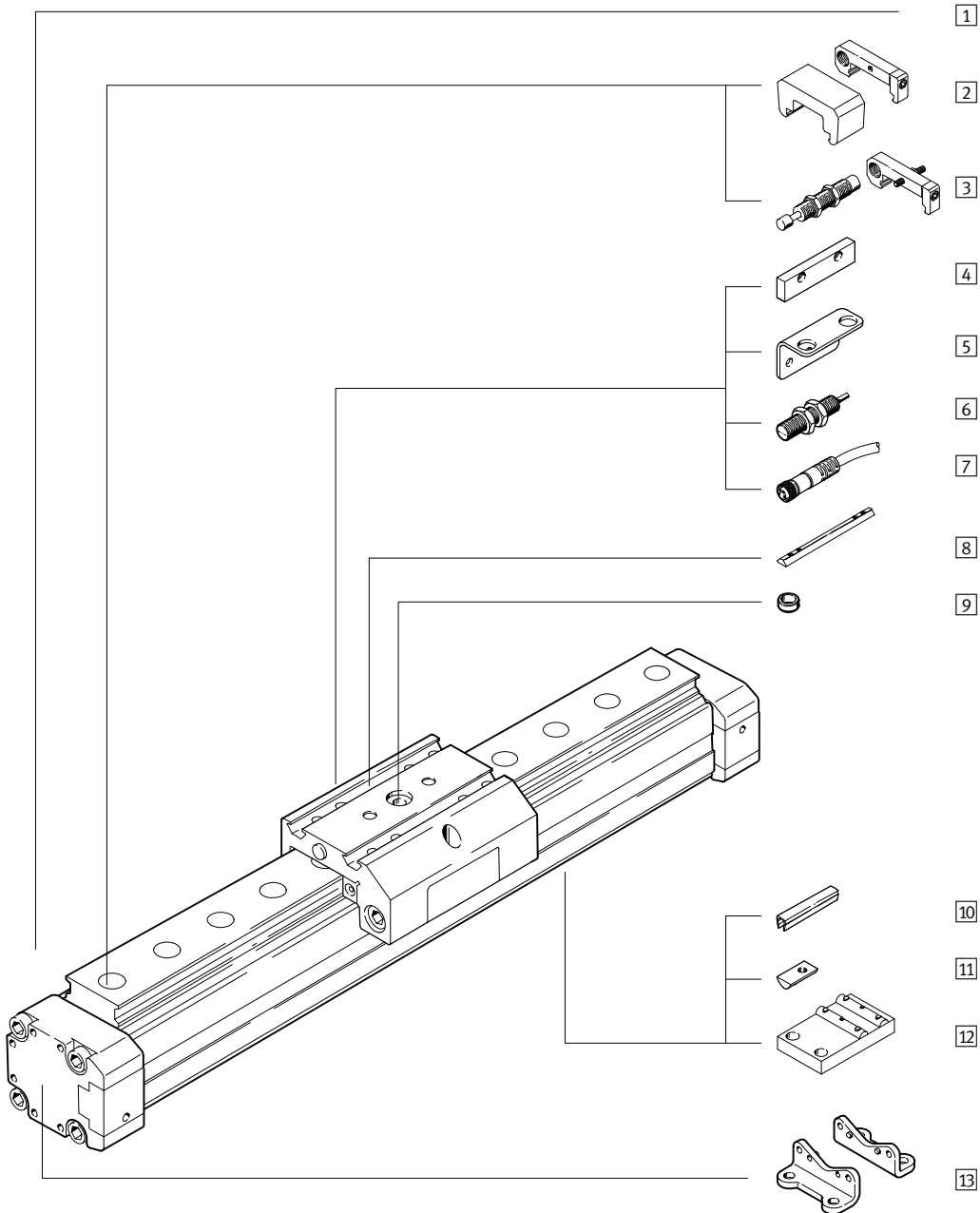
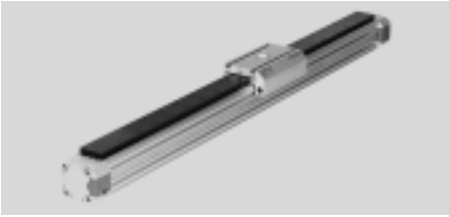

Do not use for new designs!

- 1 - Type discontinued

FESTO

Passive guide axes FDG, without drive

Peripherals overview

Variants and accessories		
Type	Brief description	→ Page/Internet
1 Passive guide axis FDG	Guide without drive	6
2 Emergency buffer with retainer A	Absorbs the energy created by the movement of the slide when it reaches the end position	22
3 Shock absorber kits C/E	Absorbs the energy created by the movement of the slide when it reaches the end position	21
4 Switching lug L	For sensing the slide position	23
5 Sensor bracket T	Adapter for mounting the SIEN proximity sensor on the axis	23
6 Proximity sensors O/P/R/W	For providing a proximity signal or safety check	25
7 Cable with socket V	For proximity sensor	25
8 Slot nut for slide X	For mounting loads and attachments on the slide	24
9 Centring sleeve Z	For centring loads and attachments on the slide	24
10 Slot cover B/S	To protect against the ingress of dirt	24
11 Slot nut for mounting slot Y	For mounting attachments	24
12 Central support M	To mount the axis	20
13 Foot mounting F	To mount the axis	20

Do not use for new designs!

- 1 - Type discontinued

Passive guide axes FDG, without drive

FESTO

Type codes

		FDG	-	25	-	500	-	ZR	-	KF	-	GK	-	
Type														
FDG	Guide unit without drive													
Size														
Stroke [mm]														
Passive guide axis														
ZR	For toothed belt axis DGE-ZR-KF													
SP	For spindle drive DGE-SP-KF													
P	For pneumatic linear drive DGPL													
Guide														
KF	Recirculating ball bearing guide													
Slide														
GK	Standard slide													
GV	Extended slide													
GA	Protected version													
Additional slide														
KL	Left													
KR	Right													

Do not use for new designs!

- 7 - Type discontinued

FESTO

Passive guide axes FDG, without drive

Type codes

		ZUB	-	2S			F		2E	Z	2T	2L	20	2V	
Accessories															
ZUB	Accessories supplied loose														
Slot cover															
...S	Sensor slot														
...B	Mounting slot														
Slot nut															
...Y	For mounting slot														
...X	For slide														
Central support															
...M	Central support														
Foot mounting															
...F	Foot mounting														
Emergency buffer and retainer															
...A	Emergency buffer and retainer														
Shock absorber kit															
...C	And retainer for GK/GV														
...E	For GA														
Centring sleeve															
...Z	Centring sleeve														
Sensor bracket															
...T	For inductive proximity sensors														
Switch lug															
L	Switch lug														
Proximity sensors															
...O	NO contact, cable														
...P	NC contact, cable														
...W	NO contact, plug														
...R	NC contact, plug														
Cable with socket															
V	2.5 m														

Do not use for new designs!

-  - Type discontinued



Passive guide axes FDG, without drive

Technical data

FESTO

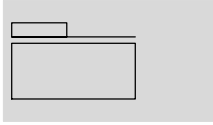
Function



-  - Size
18 ... 63
-  - Stroke length
100 ... 5,100 mm
-  - www.festo.com



General technical data			18	25	32	40	50	63
Size			18	25	32	40	50	63
Max. stroke	FDG-ZR	[mm]	1 ... 1,000	1 ... 5,100	–	1 ... 4,900	–	1 ... 4,700
	FDG-SP	[mm]	1 ... 500	1 ... 1,000	–	1 ... 1,500	–	1 ... 2,000
	FDG-P	[mm]	10 ... 1,800	10 ... 3,000	10 ... 3,000	10 ... 3,000	10 ... 3,000	10 ... 3,000
Design	Driveless linear guide unit with slide							
Guide	External recirculating ball bearing guide							
Fitting position	Any							
Cushioning	Not adjustable at either end							
	Self-adjusting at both ends							
Type of mounting	Profile mounting							
	Foot mounting							
	Direct mounting							
Increase in no-load drive torque	for DGE-...-ZR by	[Nm]	0.005	0.02	–	0.03	–	0.085
	for DGE-SP by	[Nm]	0.04	0.1	–	0.15	–	0.45
Thrust ¹⁾		[N]	5	10	7	9	12	16
Ambient temperature		[°C]	–10 ... +60					

1) Measured at FDG-18 = 0.05 m/s; FDG-25... 63 = 0.2m/s

Weights [kg]			18	25	32	40	50	63
FDG-ZR								
Basic weight at 0 mm stroke	GK		0.879	2.022	–	6.055	–	21.493
	GV		1.341	2.927	–	7.939	–	31.464
	GA		–	2.931	–	8.128	–	–
Additional weight per 100 mm stroke	GK		0.274	0.479	–	0.968	–	2.423
	GV		0.274	0.479	–	0.968	–	2.423
	GA		–	0.570	–	1.092	–	–
FDG-SP								
Basic weight at 0 mm stroke	GK		0.743	1.482	–	4.296	–	13.454
	GV		1.232	2.530	–	7.678	–	25.847
	GA		–	2.459	–	6.798	–	–
Additional weight per 100 mm stroke	GK		0.274	0.479	–	0.968	–	2.423
	GV		0.274	0.479	–	0.968	–	2.423
	GA		–	0.570	–	1.092	–	–
FDG-P								
Basic weight at 0 mm stroke	GK		0.685	1.416	2.449	4.160	8.445	13.328
	GV		1.147	2.321	3.784	6.961	13.491	23.3
	GA		–	2.211	3.282	5.989	–	–
Additional weight per 100 mm stroke	GK		0.274	0.479	0.705	0.968	1.8	2.423
	GV		0.274	0.479	0.705	0.968	1.8	2.423
	GA		–	0.570	0.808	1.092	–	–

Do not use for new designs!

- 1 - Type discontinued

Passive guide axes FDG, without drive

Technical data

FESTO

Materials

Sectional view

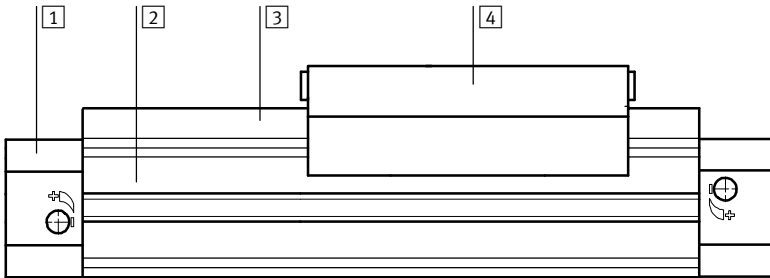

Axis		
1	End cap	Anodised aluminium
2	Profile	Anodised aluminium
3	Guide rail	∅ 18
		∅ 25 ... 63
		Hardened steel
		Hardened steel with corrosion resistant coating
4	Slide	Anodised aluminium
	Note on material	Free of copper, PTFE and silicone

Characteristic load values

The forces and torques specified refer to the centre of the guide rails. They must not be exceeded during dynamic operation. Special attention must be paid to the cushioning phase.

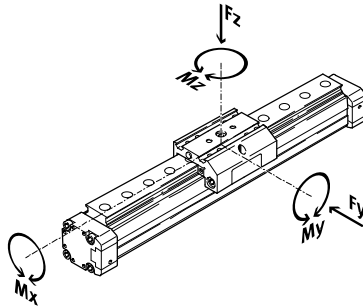

If the axis is simultaneously subjected to several of the forces and torques listed below, the following equations must be satisfied in addition to the indicated maximum loads.

$$\frac{F_y}{F_{y_{max}}} + \frac{F_z}{F_{z_{max}}} + \frac{M_x}{M_{x_{max}}} + \frac{M_y}{M_{y_{max}}} + \frac{M_z}{M_{z_{max}}} \leq 1$$

Permissible forces and torques							
Size		18	25	32	40	50	63
GK/GA – standard slide/protected slide							
F _y _{max.}	[N]	930	3,080	3,080	7,300	7,300	14,050
F _z _{max.}	[N]	930	3,080	3,080	7,300	7,300	14,050
M _x _{max.}	[Nm]	7	45	63	170	240	580
M _y _{max.}	[Nm]	23	85	127	330	460	910
M _z _{max.}	[Nm]	23	85	127	330	460	910
GV – extended slide							
F _y _{max.}	[N]	930	3,080	3,080	7,300	7,300	14,050
F _z _{max.}	[N]	930	3,080	3,080	7,300	7,300	14,050
M _x _{max.}	[Nm]	7	45	63	170	240	580
M _y _{max.}	[Nm]	45	170	250	660	920	1,820
M _z _{max.}	[Nm]	45	170	250	660	920	1,820

Do not use for new designs!

-  - Type discontinued

Passive guide axes FDG, without drive

Technical data

Maximum permissible support span l as a function of the force F

The axis may need to be supported with central supports MUP in order to limit deflection in the case of large strokes. The following diagrams serve to determine the maximum permissible support span l as a function of the force F .

Force on the surface of the slide

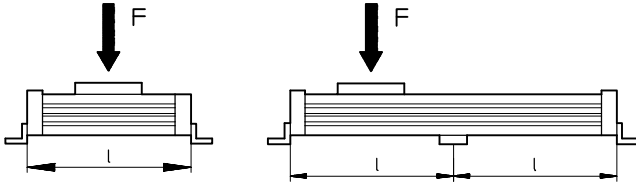

Maximum permissible support span l (without central support) as a function of the force F

Size 18...40

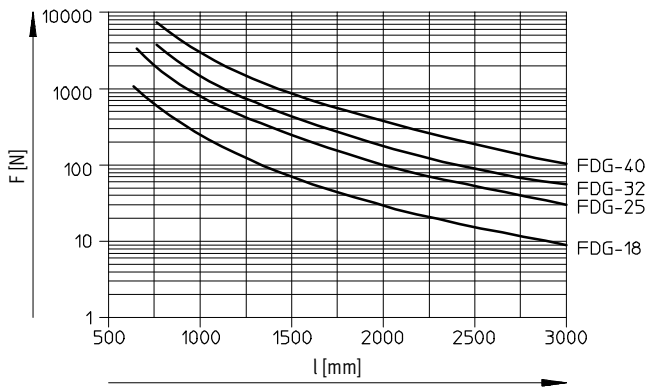

Size 50...63

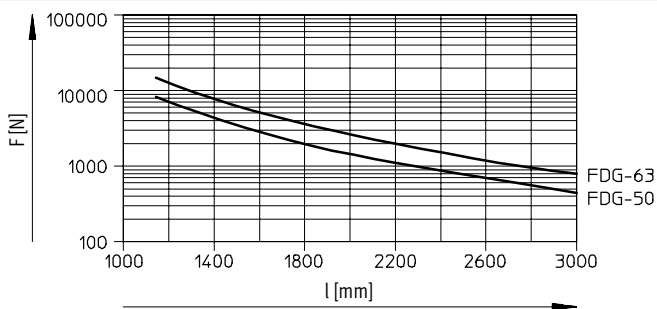

Do not use for new designs!

-  - Type discontinued

FESTO

Passive guide axes FDG, without drive

Technical data

Dimensions

Download CAD data → www.festo.com

Standard slide GK

Size 18-...

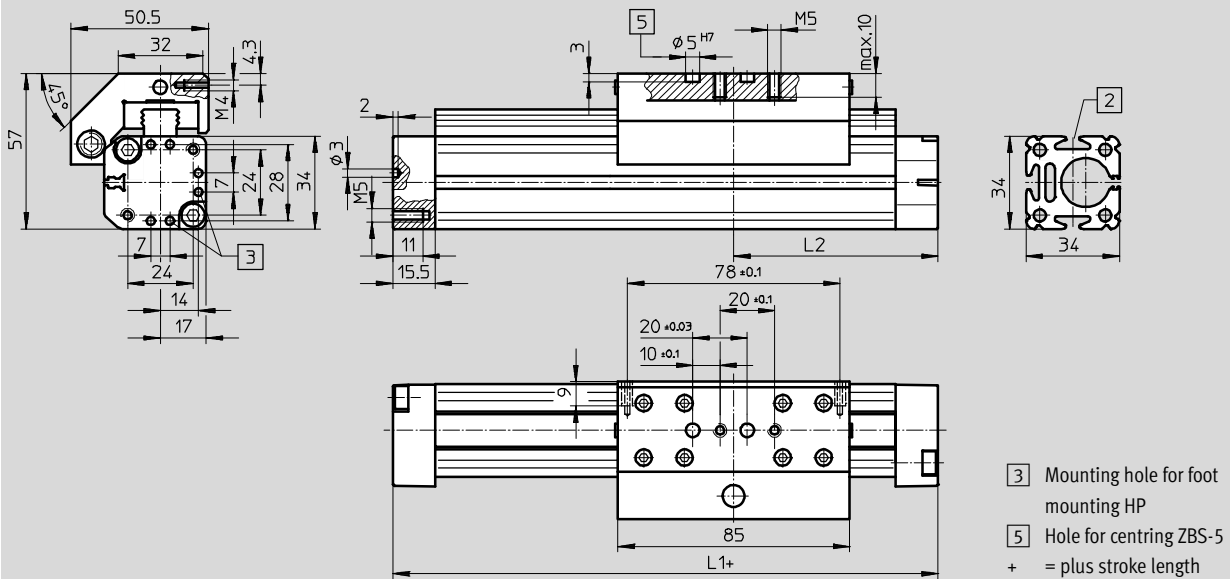

Extended slide GV

Size 18-P-GV

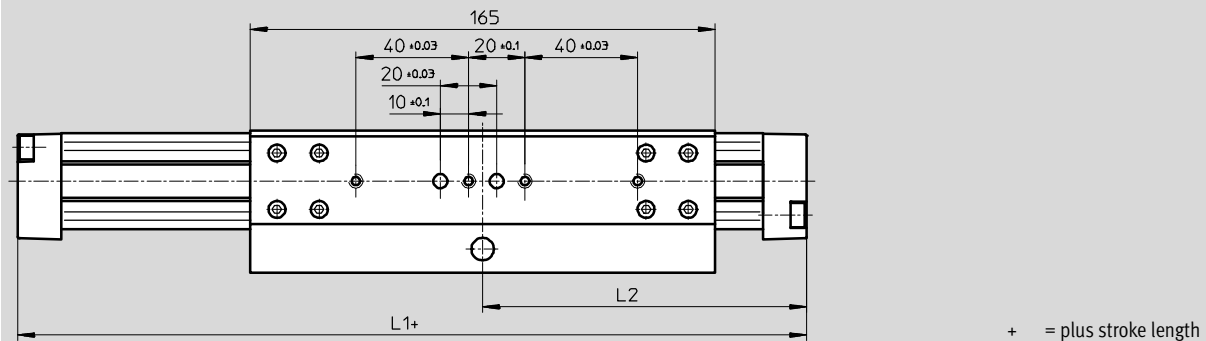

Extended slide GV

Size 18-ZR-/SP

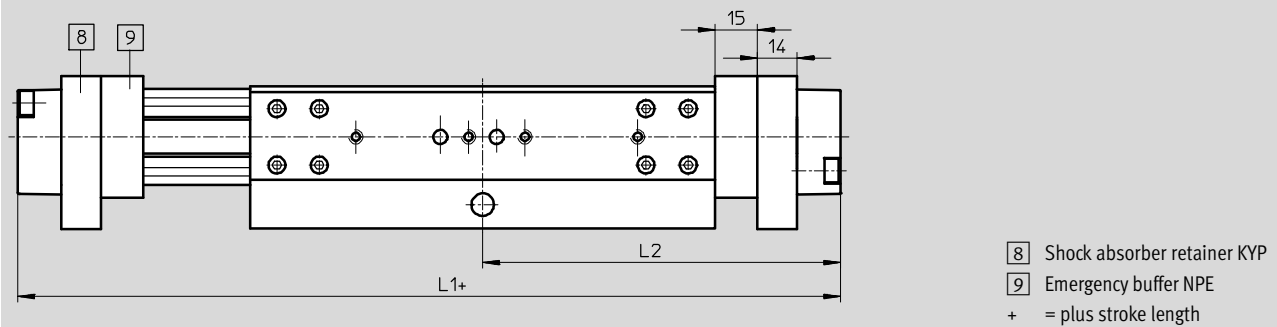

Size	L1		L2	
	GK	GV	GK	GV
FDG-18-...-P-...	150	230	75	115
FDG-18-...-ZR-...	221	301	110.5	150.5
FDG-18-...-SP-...	171	261	92	132

Do not use for new designs!

-  - Type discontinued

Passive guide axes FDG, without drive

Technical data

FESTO

Dimensions

Standard slide GK

Download CAD data → www.festo.com

Size 25-...

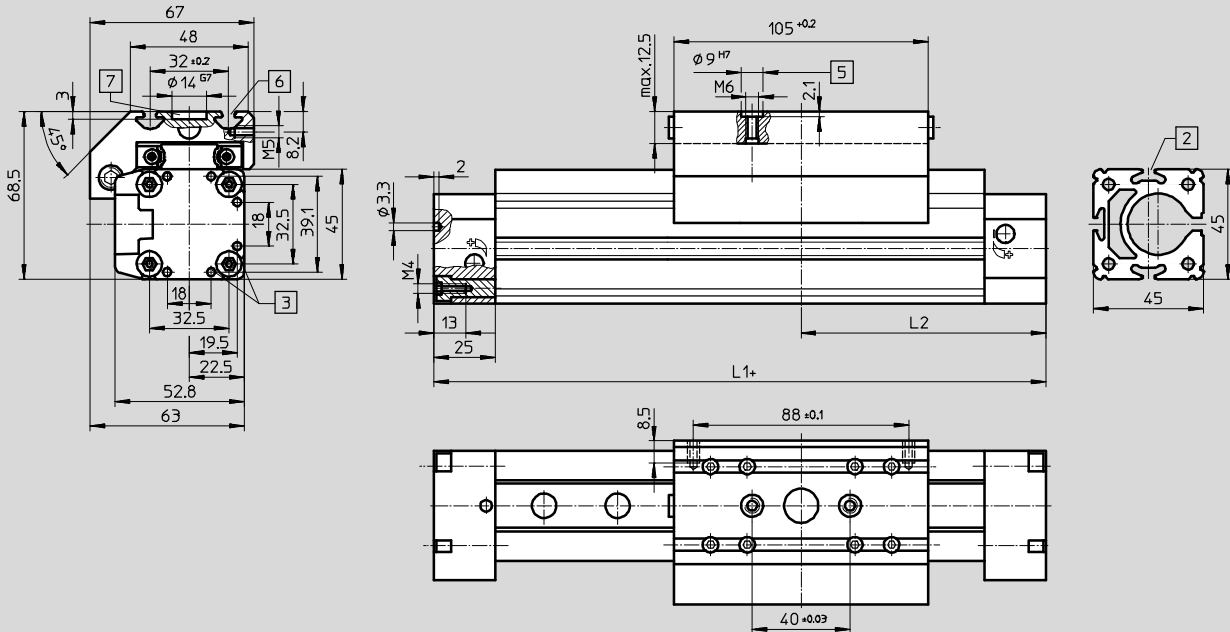

- 3 Mounting hole for foot mounting HP
 - 5 Hole for centring sleeve ZBH-9
 - 6 Mounting slot for slot nut NSTL
 - 7 Drilled hole for central mounting SLZZ
- + = plus stroke length

Extended slide GV

Size 25-P

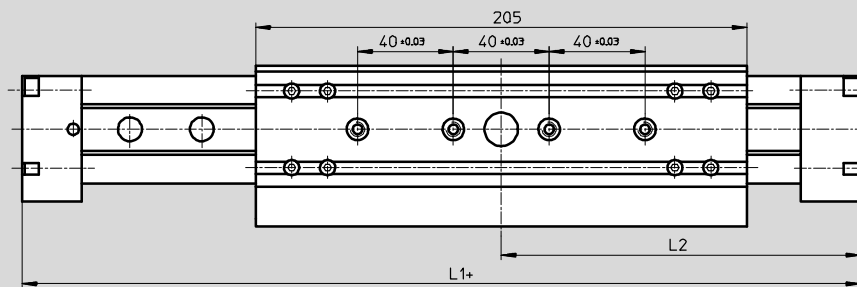

Extended slide GV

Size 25-ZR/-SP

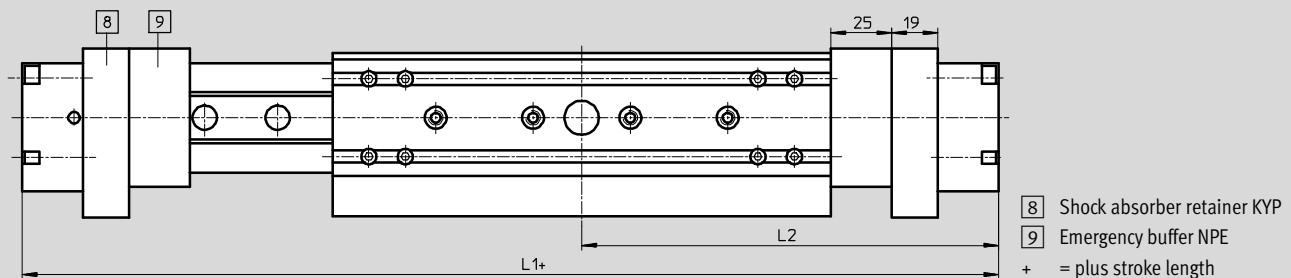

- 8 Shock absorber retainer KYP
 - 9 Emergency buffer NPE
- + = plus stroke length

Do not use for new designs!

-  - Type discontinued

FESTO

Passive guide axes FDG, without drive

Technical data

Dimensions

Download CAD data → www.festo.com

Protected version GA

Size 25-...GA

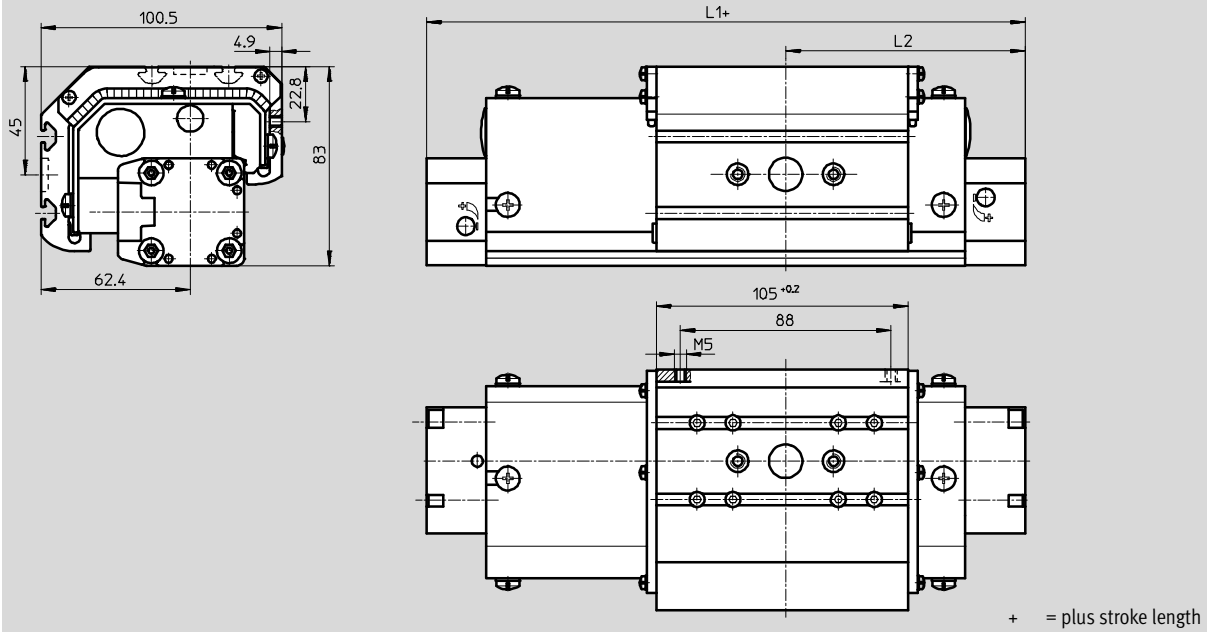

Size	L1			L2		
	GK	GV	GA	GK	GV	GA
FDG-25-...-P-...	200	300	200	100	150	100
FDG-25-...-ZR-...	326	426	326	163	213	163
FDG-25-...-SP-...	213	343	243	101.5	171.5	121.5

Do not use for new designs!

-  - Type discontinued

Passive guide axes FDG, without drive

Technical data

FESTO

Dimensions

Standard slide GK

Download CAD data → www.festo.com

Size 32...63-...

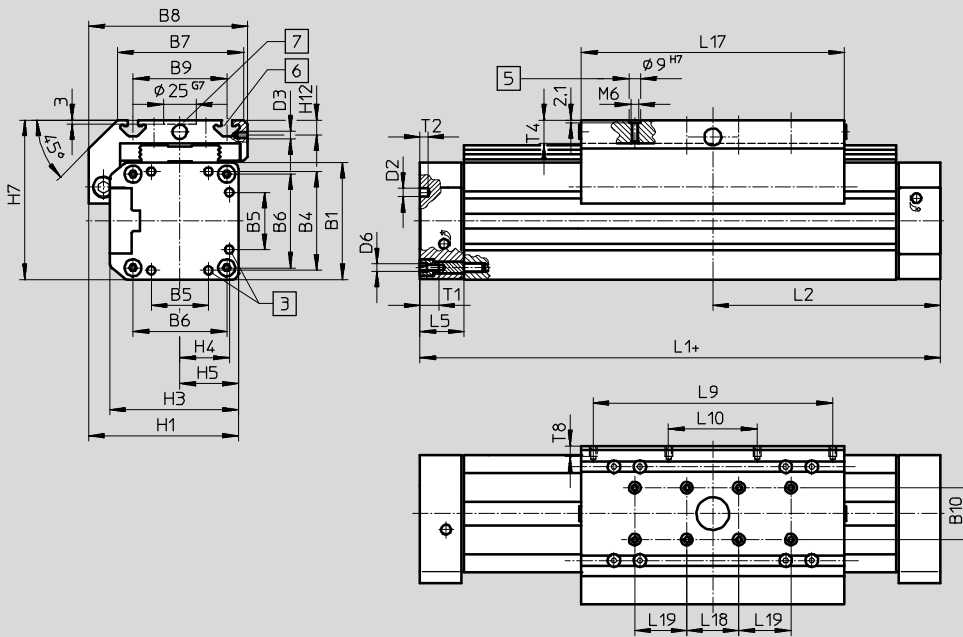

- 3 Mounting hole for foot mounting HP
- 5 Hole for centring sleeve ZBH-9
- 6 Mounting slot for slot nut NSTL
- 7 Drilled hole for central mounting SLZZ
- + = plus stroke length

Extended slide GV

Size 32...63-P

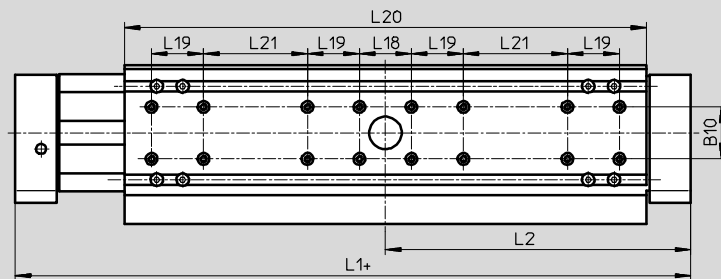

+ = plus stroke length

Extended slide GV

Size 40/63-ZR/-SP

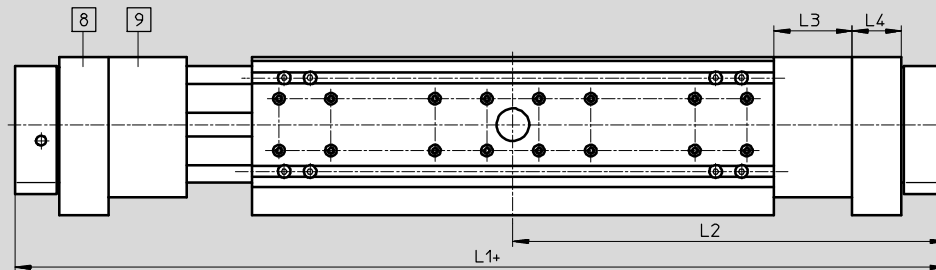

- 8 Shock absorber retainer KYP
- 9 Emergency buffer NPE
- + = plus stroke length

Profile barrel

Size 32

Size 40

Size 50

Size 63

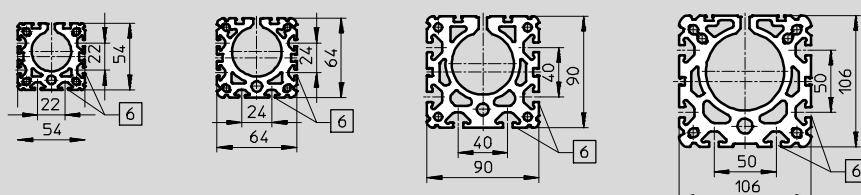

- 6 Mounting slot for slot nut NST

Do not use for new designs!

- Type discontinued

FESTO

Passive guide axes FDG, without drive

Technical data

Dimensions

Download CAD data → www.festo.com

Dust-proof version

Size 32/40...GA

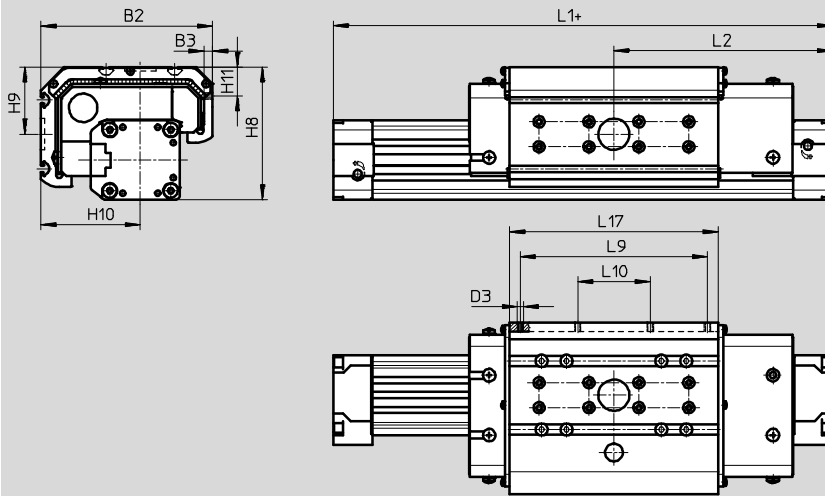

+ = plus stroke length

Size	L1			L2		
	GK	GV	GA	GK	GV	GA
FDG-32-...-P-...-	250	380	250	125	190	125
FDG-40-...-P-...-	300	470	300	150	235	150
FDG-50-...-P-...-	350	550	-	175	275	-
FDG-63-...-P-...-	400	650	-	200	325	-
FDG-40-...-ZR-...-	497	667	497	248.5	333.5	248.5
FDG-63-...-ZR-...-	738	988	-	369	494	-
FDG-40-...-SP-...-	315	545	375	153	271.5	186.5
FDG-63-...-SP-...-	406	756	-	198	378	-

Size	B1	B2	B3	B4	B5	B6	B7	B8	B9	B10	D2	D3
									±0.2		∅	
32	54	112.1	-	46	21	40	63	79	47	20	4.3	M5
40	64	137.6	7	53	28	49	78.5	96.5	55	20	4.3	M5
50	90	-	-	76	44	72	97	122	72	40	6.3	M6
63	106	-	-	89	44	83	121	142	90	40	6.3	M8

Size	D6	H1	H2	H3	H4	H5	H7	H8	H9	H10	H11	H12	L3
32	M5	72	66	62	23	27	77.5	93.1	49.5	64.5	-	8.3	-
40	M5	86	78	71.8	26.5	32	90.5	106.6	54	79.6	23.1	7	40
50	M6	115	106	99	36	45	122.5	-	-	-	-	11.5	-
63	M8	131	122	115	44.5	53	144.5	-	-	-	39.5	12.5	63

Size	L4	L5	L9	L10	L17	L18	L19	L20	L21	T1	T2	T4	T8
			±0.1	±0.1	±0.2	±0.03	±0.03		±0.1				
32	-	31	112	-	131	40	-	261	40	13.2	3	12.5	8.5
40	32	31	150	58	167	40	40	337	40	13.2	4	12.5	8.5
50	-	34	184	68	202	40	40	402	80	15.2	6	18.5	8
63	44	34	200	72	230	40	40	480	120	21.2	6	20.5	10.5

Do not use for new designs!

- 1 - Type discontinued

Passive guide axes FDG, without drive

Ordering data – Modular product system

FESTO

Order code

Mandatory data/Options

Standard slide GK

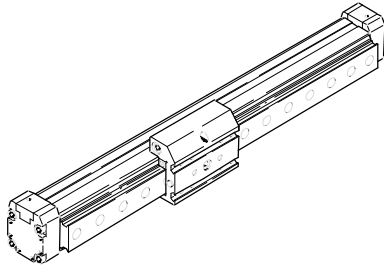

Standard slide plus additional slide GK-KL/-KR

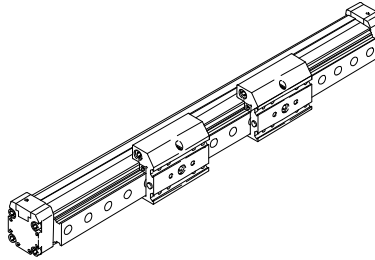

Extended slide GV

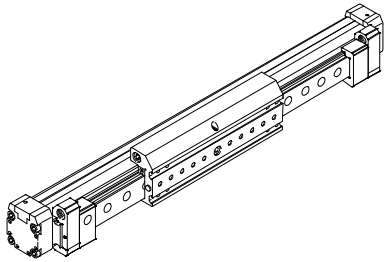

Extended slide plus additional slide GK-KL/-KR

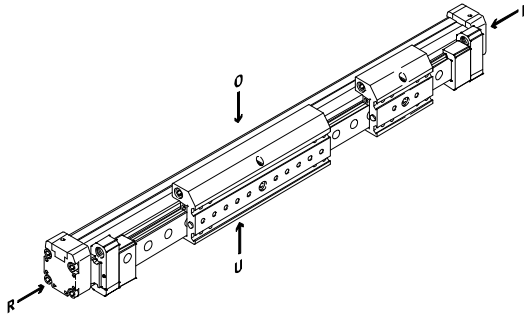

Dust-proof version GA

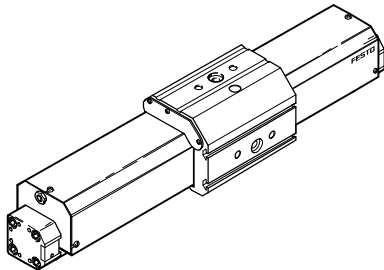

-  - Note

O = top

R = right

U = underneath

L = left

Do not use for new designs!
- 1 - Type discontinued

FESTO

Passive guide axes FDG, without drive

Ordering data – Modular product system

Order code

Options

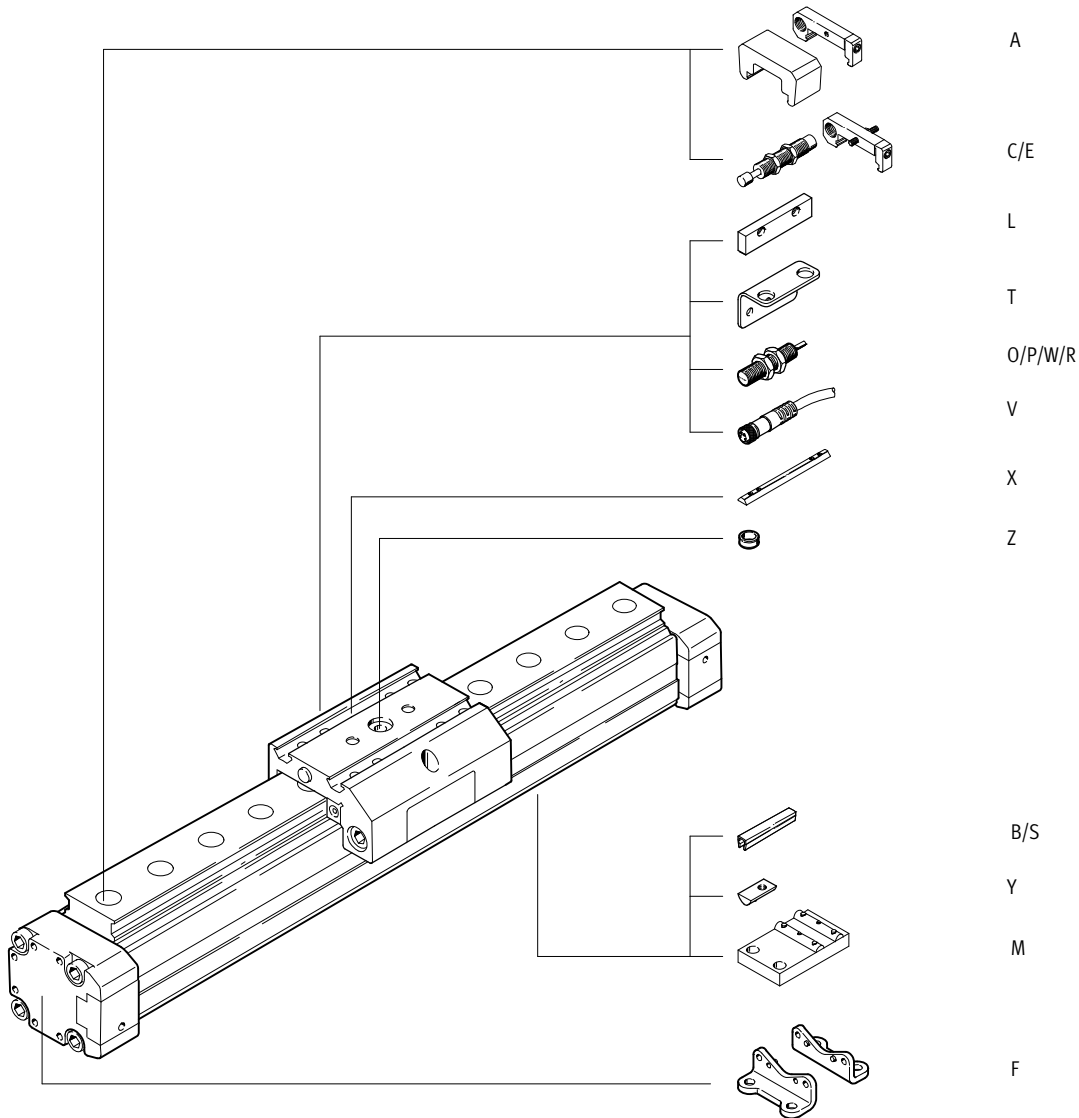

Do not use for new designs!

-  - Type discontinued

Passive guide axes FDG, without drive

Ordering data – Modular product system

FESTO

M Mandatory data							O Options →
Module No.	Drive function	Size	Stroke	Passive guide axis	Guide	Slide	Additional slide
192850	FDG	18	1 ... 5 100	ZR	KF	GK	KL
192851		25		SP		GV	KR
192852		32		P		GA	
192853		40					
192854		50					
192855		63					
Ordering example							
192853	FDG	40	500	ZR	KF	GK	

Ordering table											
Size	18	25	32	40	50	63	Condi- tions	Code	Enter code		
M Module No.	192850	192851	192852	192853	192854	192855					
Drive function	Guide unit without drive								FDG		FDG
Size	18	25	32	40	50	63		-...			
Stroke [mm] with ZR (as for corresponding drive axis)	1 ... 1 700	1 ... 5 100	-	1 ... 4 900	-	1 ... 4 700		-...			
	with SP	1 ... 1 000	-	1 ... 1 500	-	1 ... 2 000					
	with P	10 ... 1 800	10 ... 3 000	10 ... 3 000	10 ... 3 000	10 ... 3 000					
Passive guide axis	for	DGE-ZR	DGE-ZR	-	DGE-ZR	-	DGE-ZR		-ZR		
	for	DGE-SP	DGE-SP	-	DGE-SP	-	DGE-SP		-SP		
	for	DGP	DGP	DGP	DGP	DGP	DGP		-P		
Guide	Recirculating ball bearing guide								-KF		-KF
Slide	Standard								-GK		
	Extended								-GV		
	Maximum stroke [mm]										
	with ZR	(920)	(5 000)	-	(4 730)	-	(4 450)				
	with SP	(410)	(870)	-	(1 270)	-	(1 650)				
	-	Protected version					-	-	[1]	-GA	
	Maximum stroke [mm]										
	with ZR	-	(1 800)	-	(1 800)	-	-				
with SP	-	(970)	-	(1 440)	-	-					
with P	-	(2 000)	(2 000)	(2 000)	-	-					
O Additional slide	Standard slide left							[2]	-KL		
	Standard slide right							[2]	-KR		

[1] **GA** Not with accessories T, L, O, P, W, R.

[2] **KL, KR** Only with slide GK or GV.

Transfer order code

FDG - - - - **KF** - -

Do not use for new designs!

- Z - Type discontinued

FESTO

Passive guide axes FDG, without drive

Ordering data – Modular product system

Options											
Accessories	Slot cover	Slot nut	Central support	Foot mounting	Emergency buffer and retainer	Shock absorber	Centring sleeve	Sensor bracket	Switching lug	Proximity sensors	Plug socket
ZUB	...S ...B	...Y ...X	...M	...F	...A	...C ...E	...Z	...T	L	...O ...P ...W ...R	...V
ZUB	SB	4Y2X		F		2C	10Z			20	

Ordering table											
Size		18	25	32	40	50	63	Condi- tions	Code	Enter code	
↓	Accessories	Supplied separately								ZUB-	ZUB-
0	Slot cover	Sensor slot		1 ... 10					...S		
		Mounting slot		-	-	1 ... 10			...B		
	Slot nut	for mounting slot			1 ... 10				...Y		
		for slide			-	1 ... 10			...X		
	Central support	1 ... 10								...M	
	Foot mounting (kit)	1 ... 10								...F	
	Emergency buffer and retainer	1 ... 2	1 ... 2	-	1 ... 2	-	1 ... 2	[3]	...A		
		Effective stroke reduction [mm] with emergency buffer at both ends (10) (30) - (60) - (100)									
	Shock absorber and retainer	1 ... 2							[4]	...C	
		for dust-proof version		-	1 ... 2		-	-	[5]	...E	
	Centring sleeve (pack of 10)	10, 20, 30, 40, 50, 60, 70, 80, 90								...Z	
	Sensor bracket	1 ... 5		-	1 ... 5		-	1 ... 5	...T		
	Switching lug	1								L	
	Inductive proximity sensor	NO contact, cable		1 ... 5			-	1 ... 5	...O		
		NC contact, cable		1 ... 5			-	1 ... 5	...P		
		NO contact, plug		1 ... 5			-	1 ... 5	...W		
		NC contact, plug		1 ... 5			-	1 ... 5	...R		
	Cable with socket, 2.5 m	1 ... 5		-			1 ... 5	-	1 ... 5	...V	

- [3] A Not with passive guide axis P.
Mounted as standard for slides GV, GA.
- [4] C Only with slides GK and GV.

- [5] E Only with slide GA

Transfer order code

ZUB -

Do not use for new designs!

-  - Type discontinued

Passive guide axes FDG, without drive

Accessories

FESTO

Foot mounting HP

(Order code: F)

Material:

Galvanised steel

Free of copper, PTFE and silicone



HP-25

For size 18

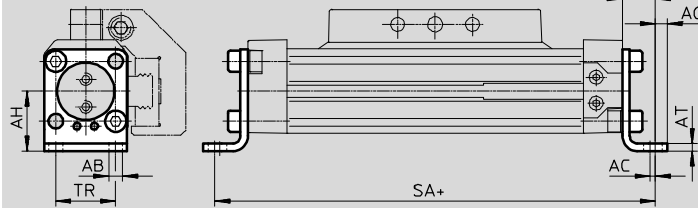

For size 25 ... 63

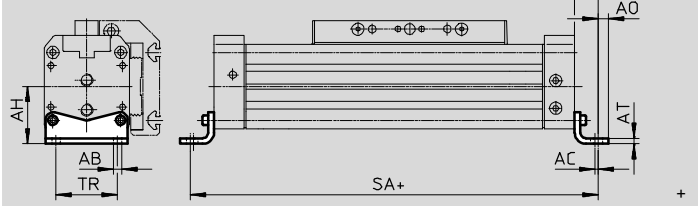

+ = plus stroke length

Dimensions and ordering data

For size	AB ∅	AC	AH	AO	AT	AU	SA	TR	Weight [g]	Part No.	Type
18	5.5	2	24	4.8	3	13.2	176	24	70	158472	HP-18
25	5.5	2	29.5	6	3	13	226	32.5	61	150731	HP-25
32	6.6	2	37	7	4	17	284	38	117	150732	HP-32
40	6.6	2	46	8.5	5	17.5	335	45	188	150733	HP-40
50	9	3	61	11	6	25	400	65	243	150734	HP-50
63	11	3	69	13.5	6	28	456	75	305	150735	HP-63

Central support MUP

(Order code: M)

Material:

Galvanised steel

Free of copper, PTFE and silicone

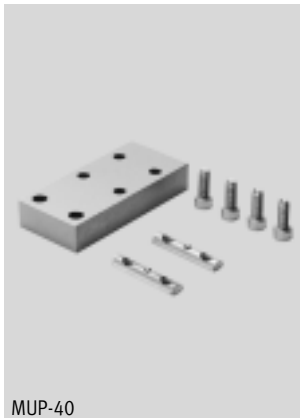

MUP-40

For sizes 18, 25

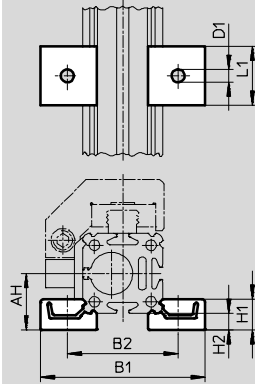

For sizes 32 ... 63

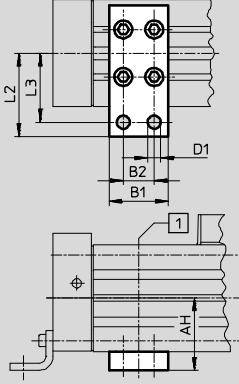

1 Position of the central support along the profile barrel is freely selectable

Dimensions and ordering data

For size	AH	B1	B2	D1 ∅	H1	H2	L1	L2	L3	Weight [g]	Part No.	Type
18	24	70.5	47	5.5	13	7	25	-	-	33	150736	MUP-18/25
25	29.5	81	58	5.5	13	7	25	-	-	33	150736	MUP-18/25
32	37	35	22	6.6	-	-	-	41.5	35	89	150737	MUP-32
40	46	35	22	6.6	-	-	-	47	40	126	150738	MUP-40
50	61	50	26	11	-	-	-	70	58	241	150739	MUP-50
63	69	50	26	11	-	-	-	77	65	340	150800	MUP-63

Do not use for new designs!

- 2 - Type discontinued

FESTO

Passive guide axes FDG, without drive

Accessories

Shock absorber YSR-...-C

(Order code: C)

Material:

Housing: Galvanised steel; piston rod:
high-alloy steel,
Seals: NBR, PUR
Free of copper, PTFE and silicone



Note

Shock absorber YSRW with
progressive characteristic
→ Internet: ysrw

Ordering data		Part No.	Type
For size	Weight [g]		
18	30	34571	YSR-8-8-C
25	70	34572	YSR-12-12-C
32	70	34572	YSR-12-12-C
40	140	34573	YSR-16-20-C
50	140	34573	YSR-16-20-C
63	240	34574	YSR-20-25-C

Shock absorber retainer KYP

(Order code: C)

Material:

Retainer: Aluminium
Sleeve: Steel, corrosion resistant

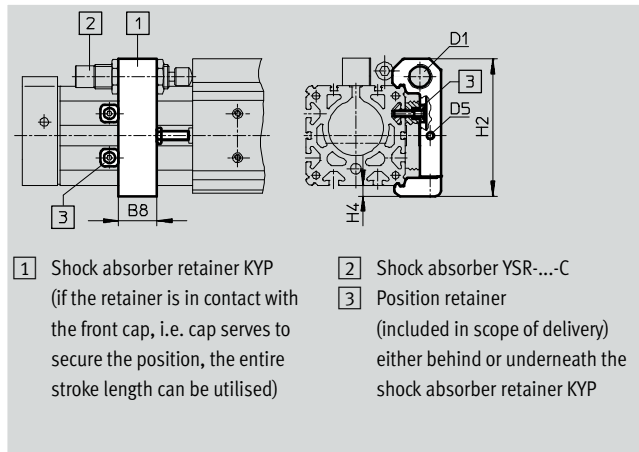

Dimensions and ordering data							
For size	B8	D1	D5	H2	H4	Weight [g]	Part No. Type
18	14	M12x1	M4	50.5	4.5	66	158907 KYP-18
25	19	M16x1	M5	69.5	6	95	158908 KYP-25
32	25	M16x1	M5	80	8	130	158909 KYP-32
40	32	M22x1.5	M5	102	8	209	158910 KYP-40
50	35	M22x1.5	M8	124	10	415	158911 KYP-50
63	44	M26x1.5	M10	152.5	11.5	609	158912 KYP-63

Do not use for new designs!

-  - Type discontinued

Passive guide axes FDG, without drive

Accessories

FESTO

Emergency buffer NPE

(Order code: A)

Material:

PUR

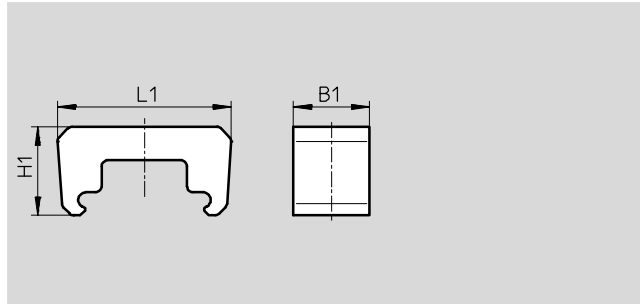
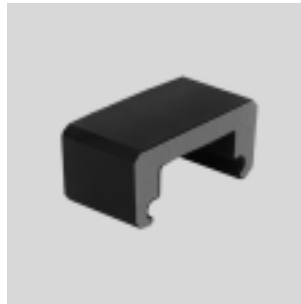

Dimensions and ordering data						
For size	B1	L1	H1	Weight [g]	Part No.	Type
18	15	43.1	28.5	6	193901	NPE-18
25	25	57	29	12	193902	NPE-25
40	40	80.5	36	41	193904	NPE-40
63	60	128.6	55	152	193906	NPE-63

-  - Note

The emergency buffer can only be used in conjunction with shock absorber retainer KYP. → 21
(A threaded pin and nut are not required.)

Shock absorber DG-GA

for protected version GA

(Order code: E)

Material:

Housing: Galvanised steel; piston rod: high-alloy steel

Seals: NBR, PUR

Free of copper, PTFE and silicone



Ordering data			
For size	Weight [g]	Part No.	Type
25	70	192875	DG-GA-25-YSR
40	140	192877	DG-GA-40-YSR

Do not use for new designs!

-  - Type discontinued

FESTO

Passive guide axes FDG, without drive

Accessories

Sensor bracket HWS

For inductive proximity sensors

(Order code: T)

Material:

Galvanised steel



Switching lug SF

(Order code: L)

Material:

Galvanised steel

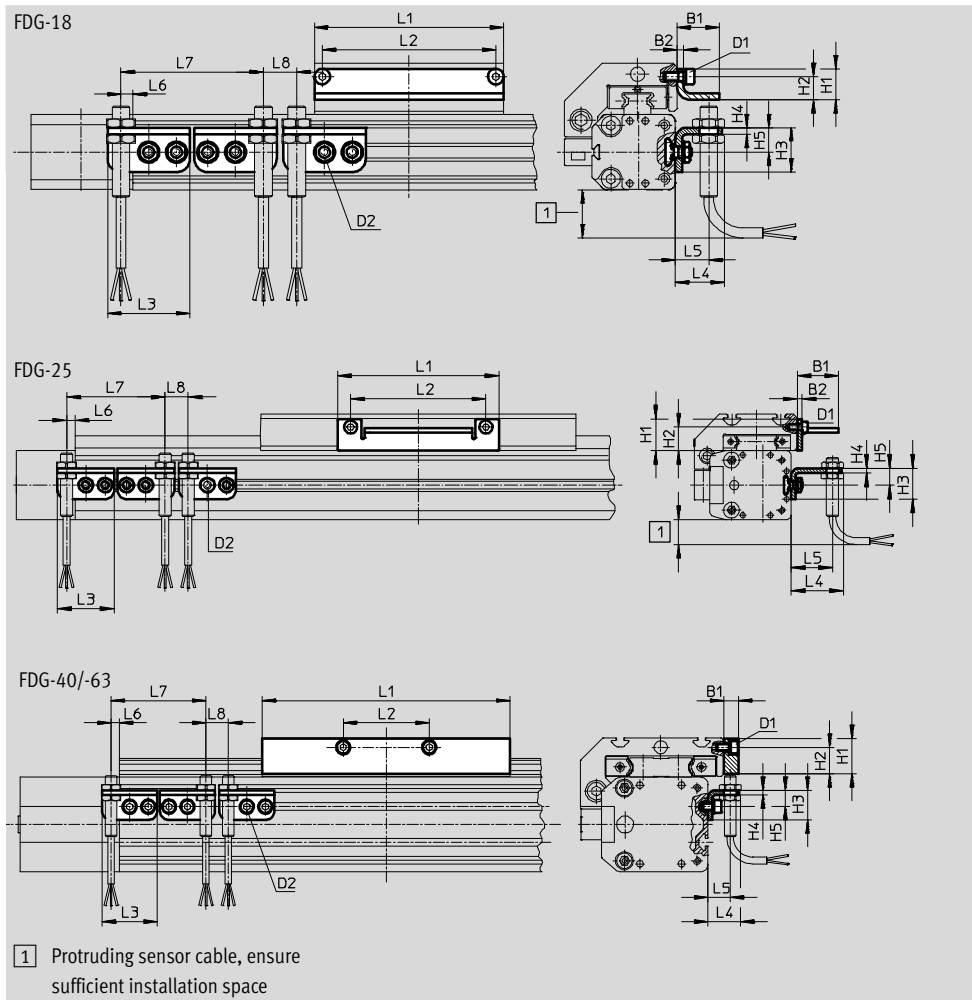

Dimensions and ordering data											
For size	D1	D2	B1	B2	H1	H2	H3	H4	H5	L1	L2
18	M4	M5	19	3	14	10.5	20	3	11	85	78
25	M5	M5	27	3	20.5	15.3	20	3	11	105	88
40	M5	M5	10	-	24	18	20	3	11	167	58
63	M8	M5	10	-	35	25	20	3	11	230	72

For size	L3	L4	L5	L6 max.	L7 min.	L8 min.	Weight [g]	Part No.	Type
18	37	22.5	15	5.5	64	15	30	188968	HWS-18/25-M8
							60	188964	SF-18
25	37	34.5	27	5.5	64	15	30	540780	HWS-25-MAB-M8
							80	540430	SF-25-MAB
40	37	22.5	15	5.5	64	15	40	188969	HWS-40-M8
							310	188966	SF-40
63	37	22.5	15	5.5	64	15	40	188970	HWS-63-M8
							630	188967	SF-63



Do not use for new designs!

- I - Type discontinued

Passive guide axes FDG, without drive

Accessories

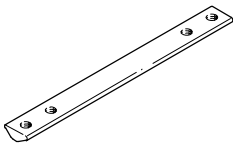
FESTO

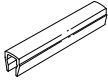
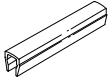
Ordering data						
	For size	Remarks	Order code	Part No.	Type	PU ¹⁾
Slot nut NST Technical data → Internet: nst						
	18, 25	For mounting slot	Y	526091	NST-HMV-M4	10
	32, 40			150914	NST-5-M5	1
	50, 63			150915	NST-8-M6	1
Slot nut NSTL Technical data → Internet: nstl						
	25	For slide	X	158410	NSTL-25	1
	32			158411	NSTL-32	1
	40			158412	NSTL-40	1
	50			158413	NSTL-50	1
	63			158414	NSTL-63	1
Centring pin/sleeve ZBS/ZBH Technical data → Internet: zbs, zbh						
	18	For slide	Z	150928	ZBS-5	10
	25 ... 63			150927	ZBH-9	10
Slot cover ABP Technical data → Internet: abp						
	32, 40	For mounting slot 0.5 m each	B	151681	ABP-5	2
	50, 63			151682	ABP-8	
Slot cover ABP-S Technical data → Internet: abp						
	18 ... 63	For sensor slot 0.5 m each	S	151680	ABP-5-S	2

1) Packaging unit quantity





Do not use for new designs!



- 7 - Type discontinued

FESTO

Passive guide axes FDG, without drive

Accessories

Ordering data – Inductive proximity sensors M8						Technical data → Internet: sien	
	Electrical connection		Switch output	LED	Cable length [m]	Part No.	Type
	Cables	M8 plug					
NO contact							
	3-wire	–	PNP	■	2.5	150386	SIEN-M8B-PS-K-L
	–	3-pin	PNP	■	–	150387	SIEN-M8B-PS-S-L
NC contact							
	3-wire	–	PNP	■	2.5	150390	SIEN-M8B-PO-K-L
	–	3-pin	PNP	■	–	150391	SIEN-M8B-PO-S-L

Ordering data – Connecting cables				Technical data → Internet: nebu			
	Electrical connection, left		Electrical connection, right		Cable length [m]	Part No.	Type
		Straight socket, M8x1, 3-pin		Cable, open end, 3-wire			
					5	541334	NEBU-M8G3-K-5-LE3
	Angled socket, M8x1, 3-pin		Cable, open end, 3-wire		2.5	541338	NEBU-M8W3-K-2.5-LE3
					5	541341	NEBU-M8W3-K-5-LE3