

Planar surface gantries EXCM

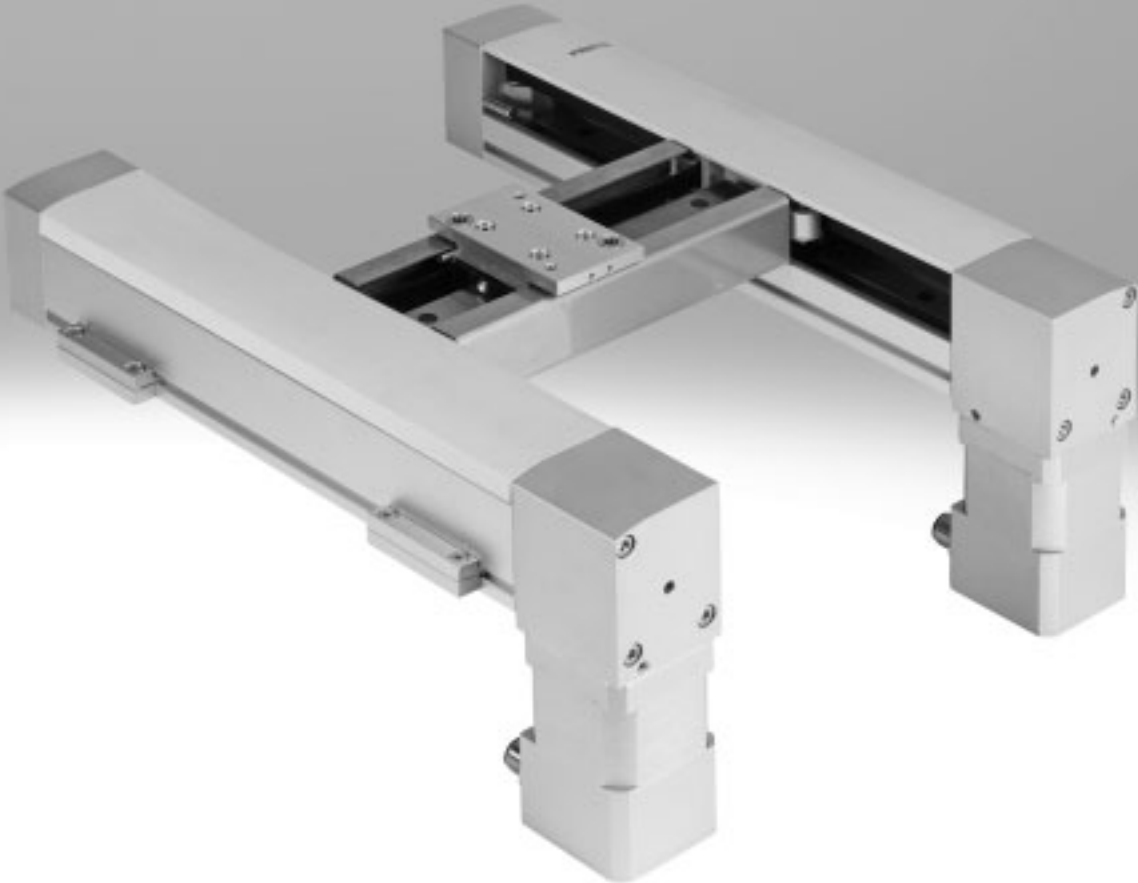

Planar surface gantries EXCM

Key features

At a glance

General

- Compact gantry distinguished by its high level of functionality in a very small installation space
- The drive design minimises the moving mass
- A perfectly matched drive and controller
- The kinematic system is actuated via 2 stepper motors with integrated optical encoder (closed loop) and one matching two-axis controller
- Can be actuated using two operating modes:
 - Direct mode via Ethernet and CAN
 - Record selection via digital I/O, Ethernet and CAN
- EXCM-30 permits flexible motor mounting

Application examples

- Feeding, pressing, joining components
- Dispensing liquids
- Mounting electronic components

Functional principle

A slide is moved in a two-dimensional space (X-axis/Y-axis) via a toothed belt. The system is powered via 2 fixed motors in position-controlled mode

(closed loop). The motors are coupled to the toothed belt. The belt is guided via pulleys in such a way that the slide

can approach any position in a working space when the motors are actuated accordingly.

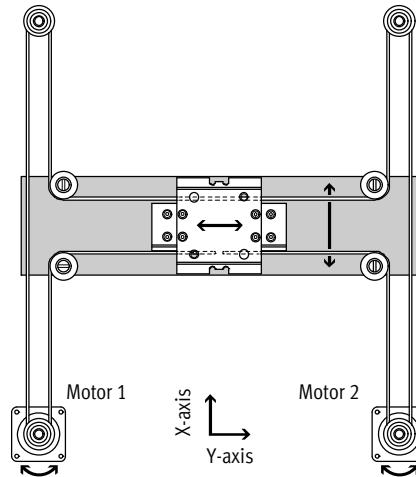
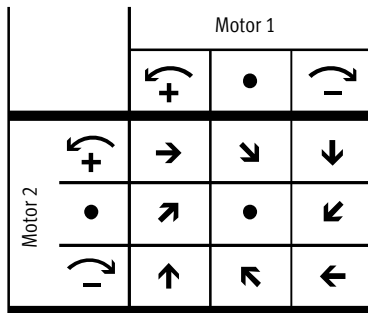

Planar surface gantry

EXCM-10



EXCM-30



Type		EXCM-10	EXCM-30
Guide		Plain-bearing guide	Recirculating ball bearing guide
Stroke of the			
	X-axis [mm]	150, 260, 300, 360, 460, 700	90 ... 700
	Y-axis [mm]	110	110, 160, 210, 260, 310, 360
Effective load	[kg]	0.5	3
Repetition accuracy	[mm]	±0.1	±0.05
Controller		Attached	Separate

Planar surface gantries EXCM

Key features

EXCM-30 – Motor mounting variants

Underneath

EXCM-30-...-B1 – Cable outlet at front

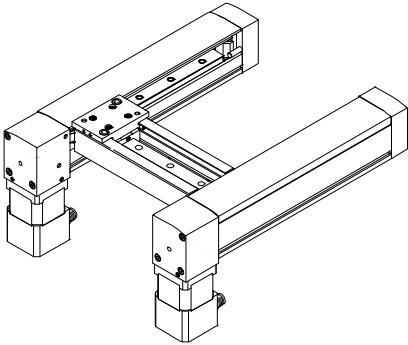

EXCM-30-...-B2 – Cable outlet at rear

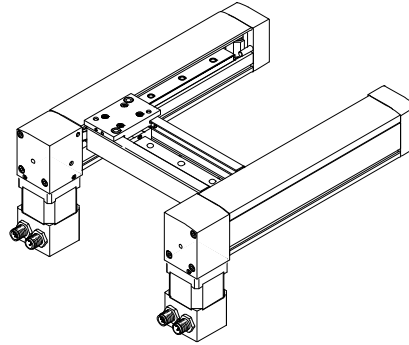

EXCM-30-...-B3 – Cable outlet inside

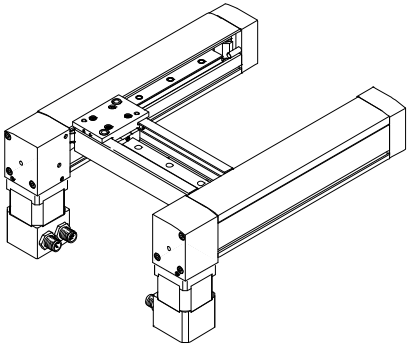

EXCM-30-...-B4 – Cable outlet outside

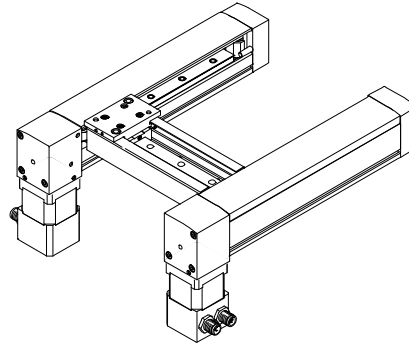

On top

EXCM-30-...-T1 – Cable outlet at front

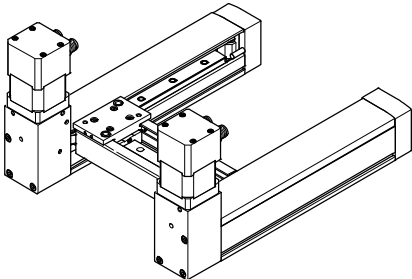

EXCM-30-...-T2 – Cable outlet at rear

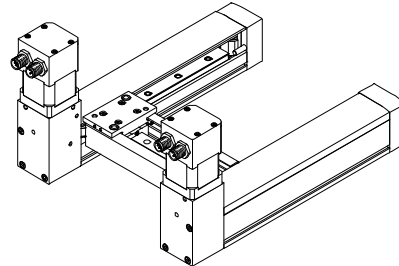

EXCM-30-...-T3 – Cable outlet inside

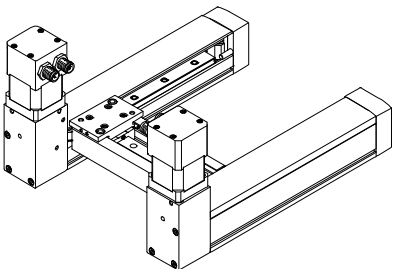

EXCM-30-...-T4 – Cable outlet outside

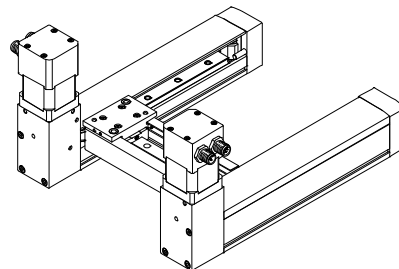

Planar surface gantries EXCM

Type codes

EXCM-10

		EXCM	-	10	-	260	-	110	-	GF	-	ST	-	B	-	E1
Type																
EXCM	Planar surface gantry															
Size																
Stroke of the X-axis [mm]																
Stroke of the Y-axis [mm]																
Guide																
GF	Plain-bearing guide															
Motor type																
ST	Stepper motors															
Motor attachment position																
B	Underneath															
Controller																
E1	Flange-mounted on the planar surface gantry															

 - Note

Ordering data → 20

Planar surface gantries EXCM

Type codes

EXCM-30

EXCM - 30 - 300 - 210 - KF - ST - B1 - E3 - DE

Type

EXCM	Planar surface gantry
------	-----------------------

Size

Stroke of the X-axis [mm]

Stroke of the Y-axis [mm]

Guide

KF	Recirculating ball bearing guide
----	----------------------------------

Motor type

ST	Stepper motors
SB	Stepper motors with brake
W	Without stepper motors

Motor attachment position

B	Underneath
B1	Underneath, cable outlets to front
B2	Underneath, cable outlets to rear
B3	Underneath, cable outlets inside
B4	Underneath, cable outlets outside
T	On top
T1	On top, cable outlets to front
T2	On top, cable outlets to rear
T3	On top, cable outlets inside
T4	On top, cable outlets outside

Controller

-	Without controller
E2	With controller, motor and encoder cable (0.5 m)
E3	With controller, motor and encoder cable (1 m)
E4	With controller, motor and encoder cable (1.5 m)
E5	With controller, motor and encoder cable (2 m)

Language of documentation

DE	German
EN	English
ES	Spanish
FR	French
IT	Italian
RU	Russian
SV	Swedish
ZH	Chinese

 Note

Ordering data → 21

Planar surface gantries EXCM

Peripherals overview

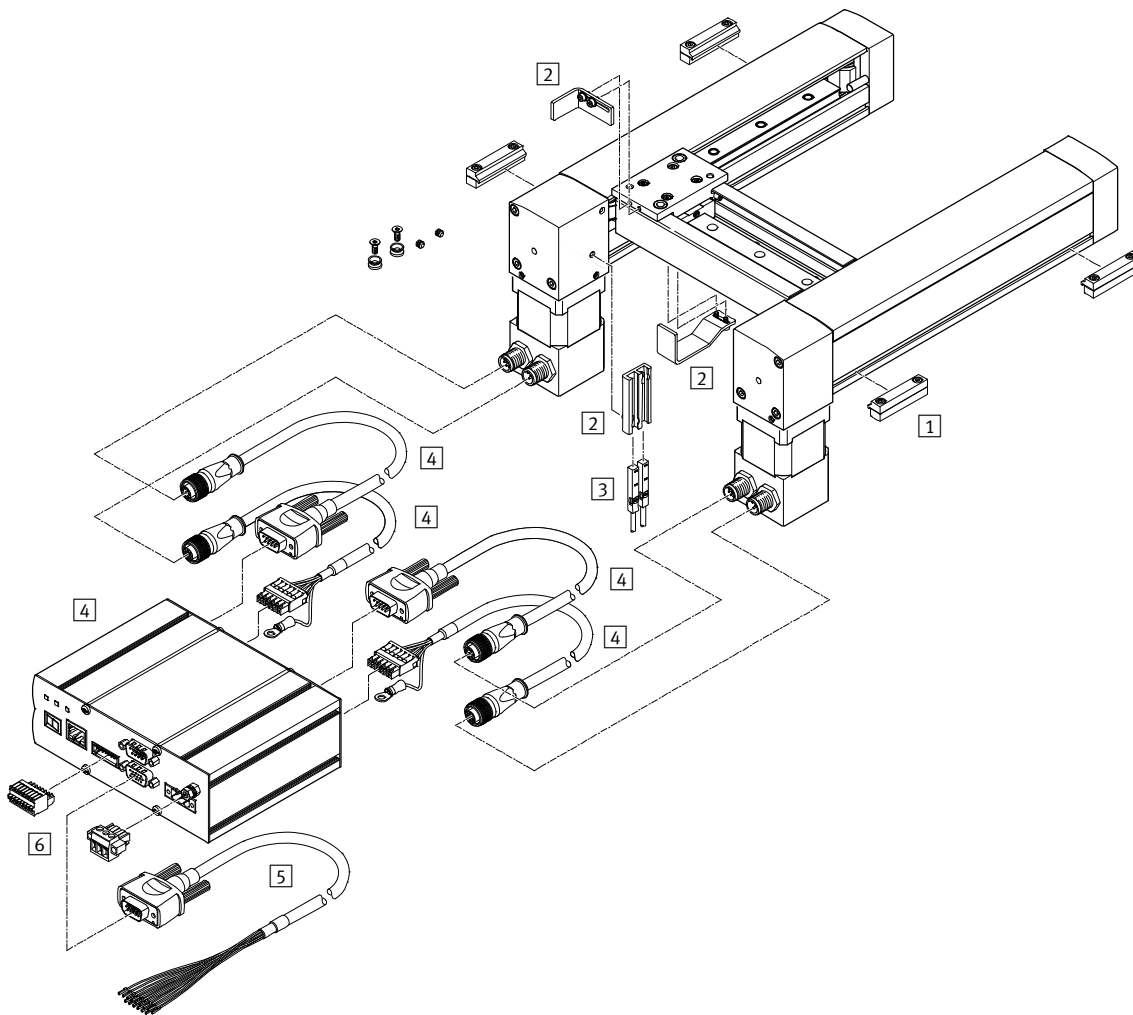

Attachments and accessories			
Type	Description		→ Page/Internet
	For EXCM-10	For EXCM-30	
1 Profile mounting MUE	–	Included in the scope of delivery: • X stroke < 500 mm: 2 pairs • X stroke ≥ 500 mm: 3 pairs	23
2 Sensor mounting EAPR	–	For homing in combination with third-party motors	22
3 Proximity sensor SIES-8M	–		23
4 Drive package comprising controller, motor, motor cable	Included in the scope of delivery of the planar surface gantry	Available with or without drive package	11
5 Pilot line NEBC-S1H15	For I/O interface to any controller	For I/O interface to any controller	23
6 Plug	Included in the scope of delivery of the planar surface gantry	Included in the scope of delivery of the drive package	–

 Note

Homing is always carried out using the mechanical stop in combination with the drive package from Festo; the sensor mounting and proximity sensor are not required in this case.

Planar surface gantries EXCM

Technical data

 Size
10, 30

General technical data			
Size		10	30
Design		Planar surface gantry	
Guide		Plain-bearing guide	Recirculating ball bearing guide
Stroke of the			
X-axis	[mm]	150, 260, 300, 360, 460, 700	100, 150, 200, 300, 400, 500
		–	90 ... 700
Y-axis	[mm]	110	110, 160, 210, 260, 310, 360
Effective load at max. dyn. rsp.	[kg]	0.5	2/3 ¹⁾
Max. process force ²⁾	[N]	–	100
Max. driving torque	[Nm]	–	0.2
Max. no-load torque	[Nm]	–	0.04 ³⁾
Max. acceleration	[m/s ²]	3	10
Max. speed	[m/s]	0.3	0.5
Repetition accuracy	[mm]	±0.1	±0.05
Mounting position		Horizontal	Any ⁴⁾
Type of mounting			
Planar surface gantry		Via through-hole and screw	Via profile mounting
Controller		–	Via H-rail, on connecting plate

- 1) Vertical/horizontal mounting position
- 2) Perpendicular to working plane, at standstill
- 3) At v=0.2 m/s and 45° diagonal travel
- 4) Motors with brake must be used in the case of vertical installation

Operating and environmental conditions			
Size		10	30
Characteristics of digital logic outputs		Not galvanically isolated	
Characteristics of logic inputs		Galvanically connected to logic potential	
Logic input specification		Based on IEC 61131-2	
Protection class		IP20	
Protective function		I ² t monitoring, following error monitoring, software end-position detection, voltage failure detection, current monitoring, temperature monitoring	
Ambient temperature	[°C]	+10 ... +45	
Storage temperature	[°C]	–10 ... +60	
Relative air humidity		0 ... 90 (non-condensing)	
Noise level	dB(A)	38	52
Duty cycle	[%]	100	
CE marking (see declaration of conformity)		In accordance with EU EMC Directive ¹⁾	

- 1) For information about the applicability of the component see the manufacturer's EC declaration of conformity at: www.festo.com/sp → User documentation.
If the component is subject to restrictions on usage in residential, office or commercial environments or small businesses, further measures to reduce the emitted interference may be necessary.

Planar surface gantries EXCM

Technical data

Materials

EXCM-10

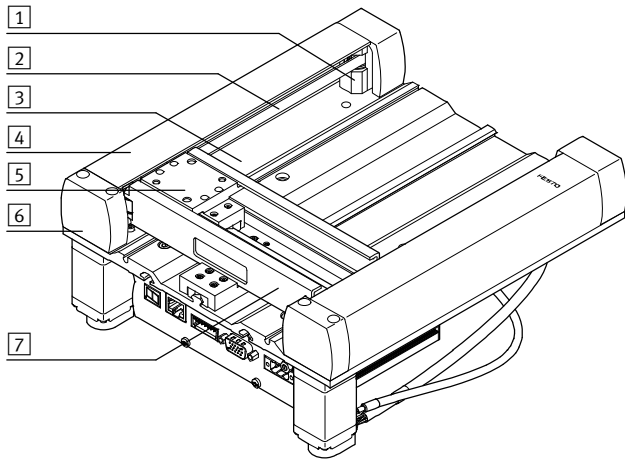

EXCM-30

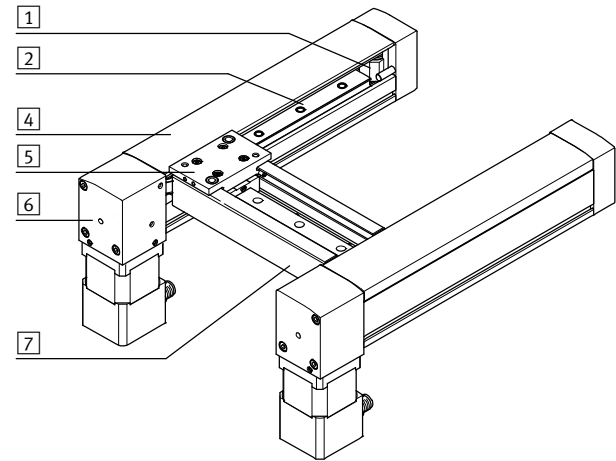

Materials

Size	10	30
1 Guide pulley	Aluminium	
2 Toothed belt	Polychloroprene with glass cord	
3 Base plate	Aluminium	-
4 Cover		
X-axis	Plastic	
Y-axis	Plastic	Stainless steel
5 Slide	Aluminium	
6 End cap	Aluminium	
7 Y-traverse	Aluminium	
- Guide	Aluminium	Steel
Ball bearings	Steel	
Note on materials	RoHS-compliant	

Weight [g]

Size	10	
Product weight with stroke (with motors and controller)		
X-axis	Y-axis	
150	110	3,300
260	110	3,800
300	110	4,000
360	110	4,200
460	110	4,700
700	110	5,700
Size		
30		
Product weight with stroke (without motors and controller)		
X-axis	Y-axis	
150	110	2,700
Additional weight per 50 mm stroke		
X-axis	237	
Y-axis	132	
Weight		
2 motors	900	
2 motors with brake	1,500	
Controller	650	

Planar surface gantries EXCM

Technical data

Characteristic load values

The indicated forces and torques refer to the slide surface. The point of application of force is the point where the centre of the guide and the longitudinal centre of the slide intersect.

They are valid for $v = 0.2 \text{ m/s}$.

These values must not be exceeded during dynamic operation. Special attention must be paid to the cushioning phase.

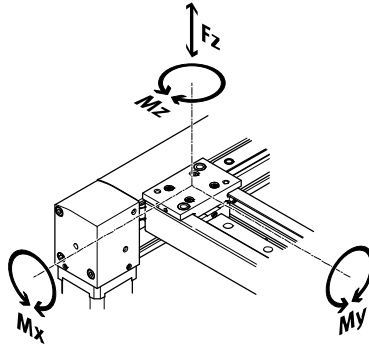

If the axis is subjected to more than two of the indicated forces and torques simultaneously, the following equation must be satisfied in addition to the indicated maximum loads.

The limit values from the table "General technical data" must additionally be taken into consideration:

Calculating the load comparison factor:

$$f_v = \frac{|F_{z,dyn}|}{F_{z,max}} + \frac{|M_{x,dyn}|}{M_{x,max}} + \frac{|M_{y,dyn}|}{M_{y,max}} + \frac{|M_{z,dyn}|}{M_{z,max}} \leq 1$$

Permissible forces and torques

Size	10	30
$F_{z,max}$ [N]	150	1345
$M_{x,max}$ [Nm]	2	5.5
$M_{y,max}$ [Nm]	0.5	10.9
$M_{z,max}$ [Nm]	2	5.5

Feed forces [N]

Size	30						
Stroke of the Y-axis [mm]	110	160	210	260	310	360	
Travel in X direction	55	55	55	50	40	34	
Travel in Y direction	55	55	46	38	32	28	
Travel 45° diagonal	35	35	35	30	25	23	

Weight of the Y-traverse [g]

Size	30						
Stroke of the Y-axis [mm]	110	160	210	260	310	360	
Y-traverse	670	800	930	1,070	1,200	1,330	

Note

The weight forces due to load when the gantry is mounted vertically must be taken into consideration in the

feed force. This is done by adding the weight of the Y-traverse to the load when the X-axis is vertical. The feed

force is reduced by the value of the weight force with vertical travel

upwards and increased with vertical travel downwards.

For EXCM-30: Calculating service life

The service life of the guide depends on the load. To provide a rough indication of the service life of the guide, the

graph below plots the load comparison factor f_v against the service life.

These values are only theoretical. You must consult your local contact person

at Festo for load comparison factors f_v greater than 1.5.

Load comparison factor f_v as a function of service life

Example:

A user wants to move an X kg load. Using the formula $\rightarrow 9$ gives a value of 1.5 for the load comparison factor f_v . According to the graph, the

guide would have a service life of approx. 1000 km. Reducing the acceleration reduces the M_z and M_y values. A load comparison factor f_v of 1 now gives a service life of 3500 km.

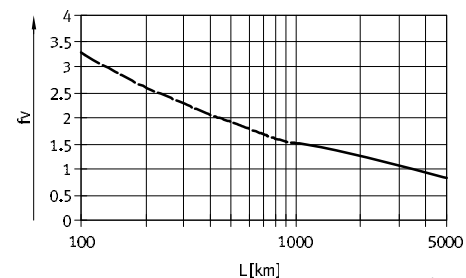

Applies only to EXCM-30!

Planar surface gantries EXCM

Technical data

EXCM-30 – Number of profile mountings

Different numbers of profile mountings must be used depending on the mounting position and stroke of the X-axis.

Horizontal mounting position
Stroke < 500 mm

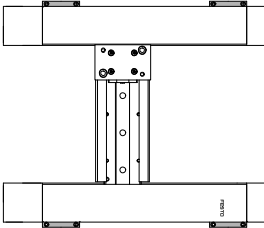

Stroke ≥ 500 mm

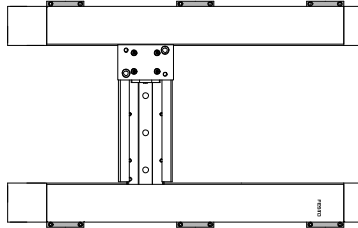

Vertical mounting position
Stroke < 500 mm

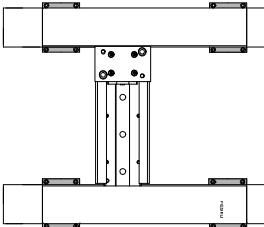

Stroke ≥ 500 mm

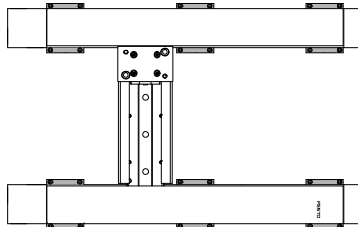

Stroke of the X-axis [mm]	Number of profile mountings	
	Horizontal mounting position	Vertical mounting position
100 ... 500	2 per profile, inside or outside	4 per profile, inside and outside
500 ... 700	3 per profile, inside or outside	6 per profile, inside and outside

Planar surface gantries EXCM

Technical data

Technical data – Controller	
Functional principle	Cascade controller with P position controller, PI speed controller, PI current controller; Current control, within the cascade controller PWM MOSFET power end stage
Operating mode	Direct mode Record selection
Rotary position encoder	Optical encoder, 2,000 steps/rev.
Display	7-segment display
Input encoder interface	RS422
Adjustable current reduction	Via software
Nominal current setting	Via software
Step adjustment	Via software
Switching logic	NPN (negative switching)
Braking resistor [Ω]	15
Mains filter	Integrated

Electrical data – Controller		
For EXCM size	10	30
Max. intermediate circuit voltage [V DC]	28	
Nominal current per phase, effective [A]	1.4	3
Load supply		
Nominal voltage [V DC]	24	
Nominal current [A]	2.8	6
Peak current [A]	8	
Logic supply		
Nominal voltage [V DC]	24 ±15%	
Nominal current [A]	0.3	
Max. current of digital logic outputs [mA]	100	

Technical data – Fieldbus interface			
Interfaces	I/O	CANopen	Ethernet
Number of digital logic outputs	5		
Number of digital logic inputs	9		
Operating range of logic inputs [V DC]	8 ... 30		
Process coupling	31 positioning records		
Communication profile	–	FHPP	TCP/IP, FHPP
Max. fieldbus transmission rate [Mbps]	–	1	100

Mechanical data – Motor		
Size	10	30
Nominal torque [Nm]	0.009	0.04
Holding torque [Nm]	0.009	0.04

CANopen® is a registered trademark of its respective trademark holder in certain countries.

Planar surface gantries EXCM

Technical data

Pin allocation

Front plate

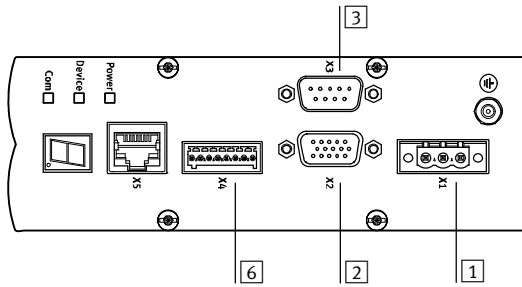

Reverse side

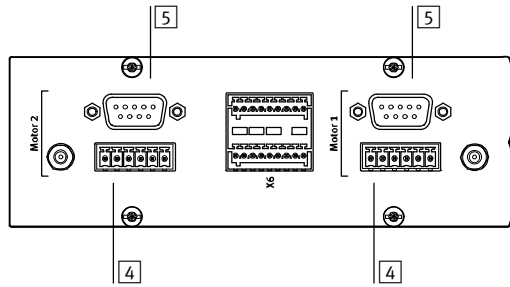

1 X1 Power supply

Pin	Function
1	+24 V logic Logic supply
2	+24 V load Load supply
3	0 V Reference potential

2 X2 I/O interface

Pin	Function
1	+24 V Ready Ready for communication
2	In 1 Positioning record bit 1
3	In 2 Positioning record bit 2
4	In 3 Positioning record bit 3
5	In 4 Positioning record bit 4
6	In 5 Positioning record bit 5
7	In 6 Not used
8	Start Start input
9	Enable Enable input
10	Reset Reset input
11	Ready Ready output
12	Fault Fault output
13	Acknowledge Acknowledge output
14	MC Motion complete
15	0 V Reference potential

Planar surface gantries EXCM

Technical data

3 X3 CAN interface

Pin	Function
1	n.c.
2	CAN_L CAN low
3	GND Reference potential
4	n.c.
5	n.c.
6	n.c.
7	CAN_H CAN high
8	n.c.
9	n.c.

4 Motor connection – supply

Pin	Function
1	A String A
2	A/ String A/
3	B String B
4	B/ String B/
5	BR+ 24 V brake connection
6	BR- 0 V brake connection

5 Motor connection – encoder

Pin	Function
1	A
2	B
3	N
4	0 V Reference potential for encoder
5	5 V Auxiliary supply for encoder
6	A/
7	B/
8	N/
9	n.c.

6 X4 Emergency stop interface

Pin	Function
1	+24 V logic Logic supply
2	TO Interrupt motor voltage (at 0 V)
3	ES Trigger braking ramp (at 0 V)
4	RB Release brake (at 24 V)
5	FAULT Fault
6	DIAG1
7	DIAG2
8	0 V Reference potential

Planar surface gantries EXCM

Technical data

Dimensions

Download CAD data → www.festo.com

EXCM-10

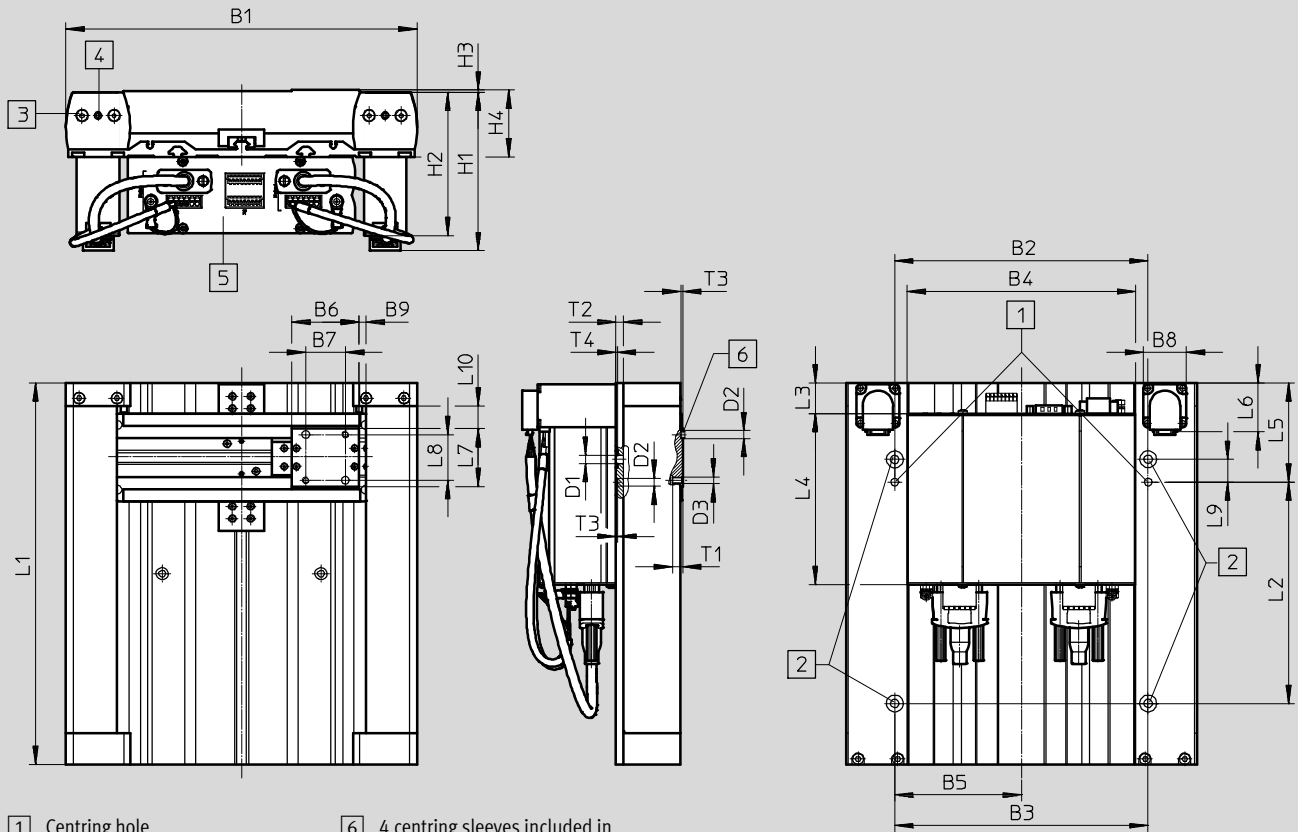

- | | |
|--|---|
| <ul style="list-style-type: none"> 1 Centring hole 2 Mounting hole 3 Screw for setting the toothed belt tension 4 Threaded pin for securing the adjusting screws 5 Controller | <ul style="list-style-type: none"> 6 4 centring sleeves included in the scope of delivery of the planar surface gantry <ul style="list-style-type: none"> – 2 centring sleeves for the mounting hole – 2 centring sleeves for mounting on the slide |
|--|---|

Planar surface gantries EXCM

Technical data

Type	B1	B2	B3	B4	B5	B6	B7	B8	B9
		±0.03	±0.2		±0.2		±0.03		
EXCM-10-...	230	166	166	149	83	44	26	28	4.7

Type	D1	D2	D3	H1	H2	H3	H4	L3	L4
	∅	∅ H7		+1.35/-1.15			±1		
EXCM-10-...	5.5	5	M4	103.7	93.2	1.6	44.8	0 ... 50	112

Type	L5	L6	L7	L8	L9	L10	T1	T2	T3	T4
	±0.1			±0.03	±0.1				+0.3	
EXCM-10-...	65	32	38	30	15	14.8	6.7	5	1.2	1

Stroke-dependent dimensions

Type	L1	L2
	+0.4	±0.2
EXCM-10-150-110-...	250	145
EXCM-10-260-110-...	360	255
EXCM-10-300-110-...	400	295
EXCM-10-360-110-...	460	355
EXCM-10-460-110-...	560	455
EXCM-10-700-110-...	800	695

Planar surface gantries EXCM

Technical data

Dimensions

Download CAD data → www.festo.com

EXCM-30

Motor attachment position – Underneath

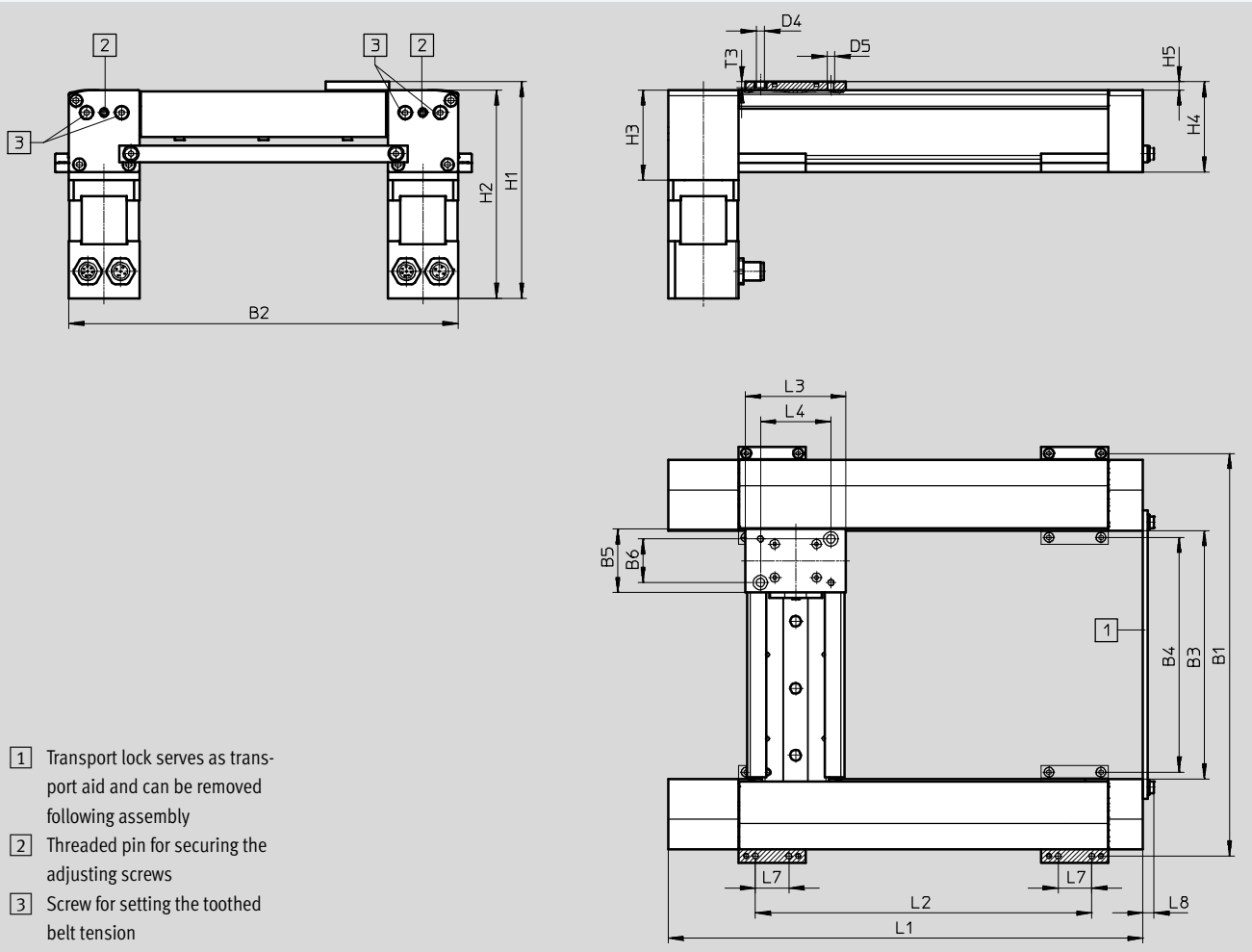

Motor interface

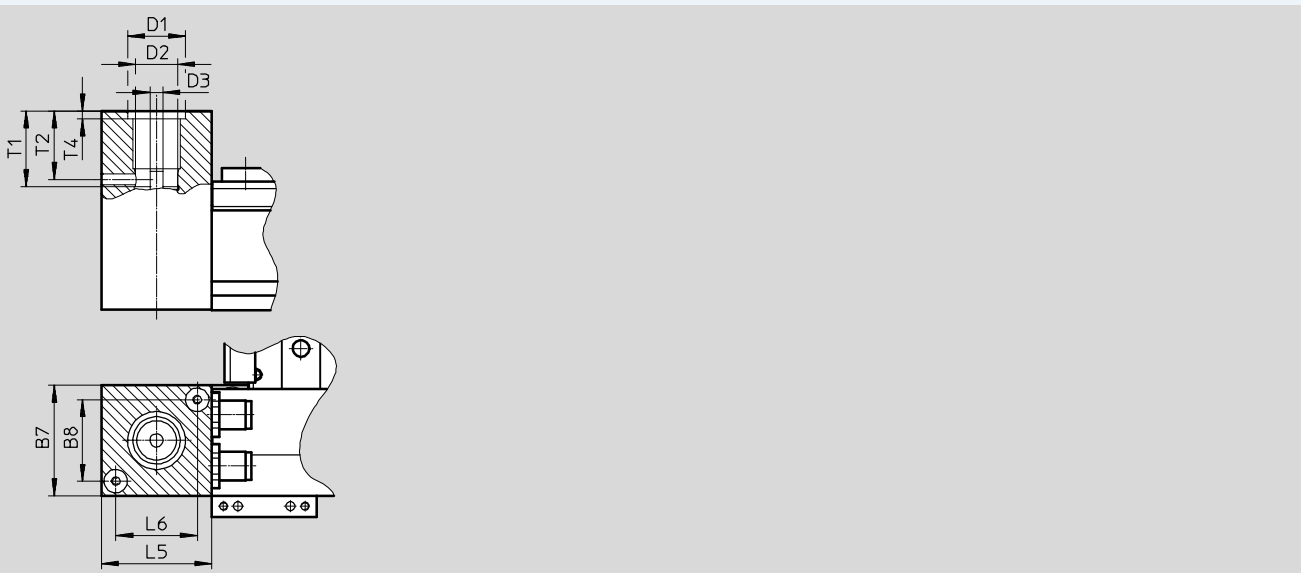

Planar surface gantries EXCM

Technical data

Type	B5	B6 ±0.03	B7	B8 ±0.1	D1 ∅ H7	D2 ∅	D3 ∅ f8	D4 ∅ H8	D5
EXCM-30-...	38	26	42	31	22	16	5	5	M4

Type	H1		H2		H3	H4	H5	L3
	EXCM-...-ST	EXCM-...-SB	EXCM-...-ST ±0.7	EXCM-...-SB				
EXCM-30-...	129.2	186.2	124.2	181.2	53.8	54	5	60

Type	L4 ±0.03	L5	L6 ±0.1	L7	L8	T1	T2	T3	T4
EXCM-30-...	42	42	31	20	6.6	28.7	26	3.7	3

Stroke-dependent dimensions

Stroke of the X-axis	L1	L2 ±0.2	Stroke of the Y-axis	B1	B2	B3	B4
150	283	200.5	160	290	282	198	190
200	333	250.5	210	340	332	248	240
300	433	350.5	260	390	382	298	290
400	533	450.5	310	440	432	348	340
500	633	550.5	360	490	482	398	390
90 ... 700	133 + stroke	50.5 + stroke					

Planar surface gantries EXCM

Technical data

Dimensions

Download CAD data → www.festo.com

EXCM-30

Motor attachment position – On top

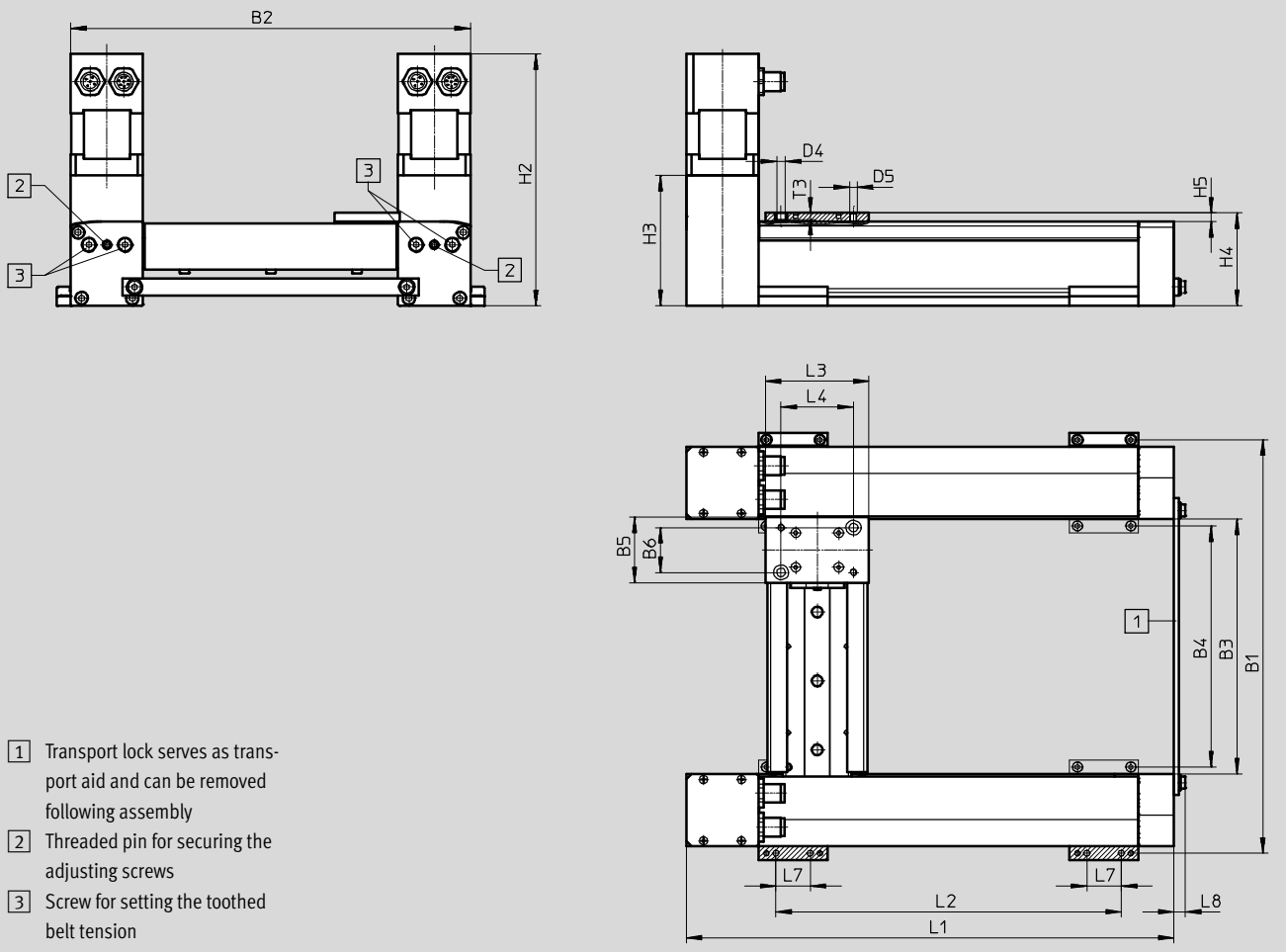

Motor interface

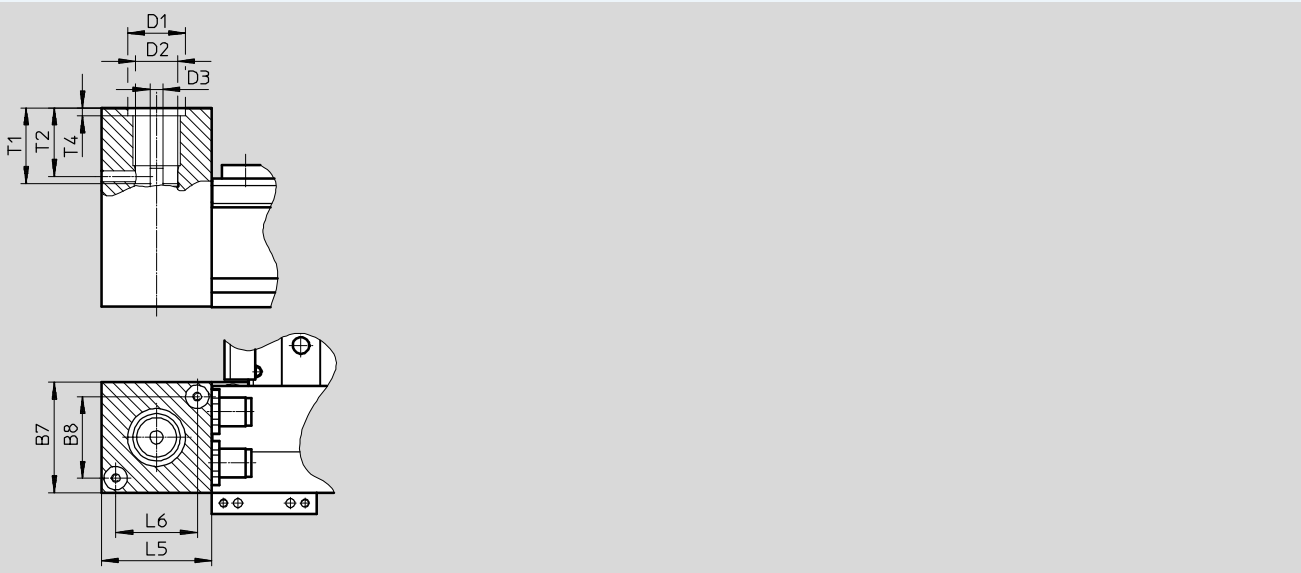

Planar surface gantries EXCM

Technical data

Type	B5	B6 ±0.03	B7	B8 ±0.1	D1 ∅ H7	D2 ∅	D3 ∅ f8	D4 ∅ H8
EXCM-30-...	38	26	42	31	22	16	5	5

Type	D5	H2		H3	H4	H5	L3	L4 ±0.03
		EXCM-...-ST ±1	EXCM-...-SB					
EXCM-30-...	M4	146.2	203.2	75.6	54	5	60	42

Type	L5	L6 ±0.1	L7	L8	T1	T2	T3	T4
EXCM-30-...	42	31	20	6.6	28.7	26	3.7	3

Stroke-dependent dimensions

Stroke of the X-axis	L1	L2 ±0.2	Stroke of the Y-axis	B1	B2	B3	B4
150	283	200.5	160	290	282	198	190
200	333	250.5	210	340	332	248	240
300	433	350.5	260	390	382	298	290
400	533	450.5	310	440	432	348	340
500	633	550.5	360	490	482	398	390
90 ... 700	133 + stroke	50.5 + stroke					

Planar surface gantries EXCM

Technical data

Dimensions

Download CAD data → www.festo.com

Controller

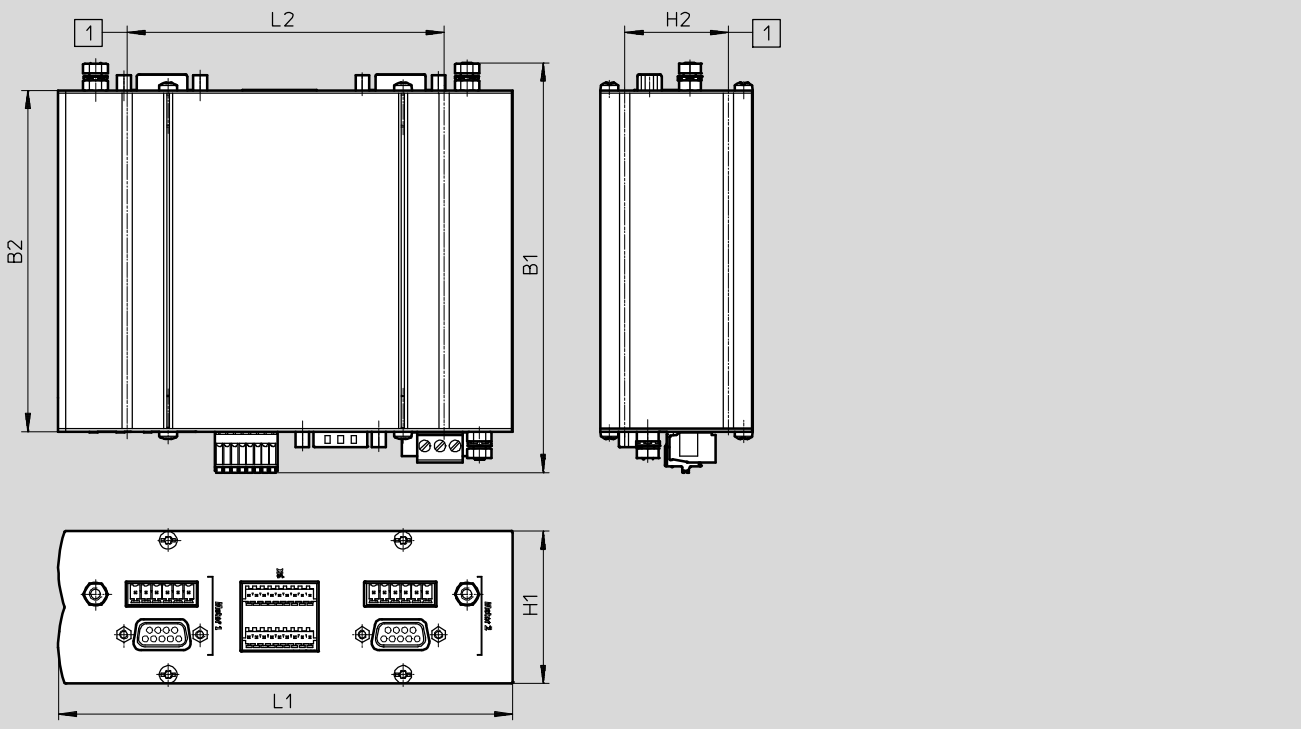

B1	B2	H1	H2	L1	L2
134.4	112	50	32	149	104

Ordering data

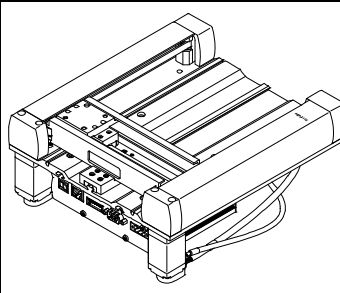
EXCM-10	Stroke (X-axis) [mm]	Part No.	Type
	150	1801920	EXCM-10-150-110-GF-ST-B-E1
	260	1801915	EXCM-10-260-110-GF-ST-B-E1
	300	1801917	EXCM-10-300-110-GF-ST-B-E1
	360	1801918	EXCM-10-360-110-GF-ST-B-E1
	460	1801916	EXCM-10-460-110-GF-ST-B-E1
	700	1801919	EXCM-10-700-110-GF-ST-B-E1

Planar surface gantries EXCM

Ordering data – Modular products

Ordering table					
Size		30	Condi- tions	Code	Enter code
M	Module No.	2226101			
	Product type	EXCM series M		EXCM	EXCM
	Size	30		-30	30
	Stroke of the X-axis	[mm] 100		-100	
		[mm] 150		-150	
		[mm] 200		-200	
		[mm] 300		-300	
		[mm] 400		-400	
		[mm] 500		-500	
		[mm] 90 ... 700		-...	
	Stroke of the Y-axis	[mm] 110		-110	
		[mm] 160		-160	
		[mm] 210		-210	
		[mm] 260		-260	
		[mm] 310		-310	
		[mm] 360		-360	
	Guide	Recirculating ball bearing guide		-KF	KF
	Motor type	Stepper motors		-ST	
		Stepper motors with brake		-SB	
		Without stepper motors	¹	-W	
	Motor attachment position	Underneath	²	-B	
		Underneath, cable outlets to front		-B1	
		Underneath, cable outlets to rear		-B2	
		Underneath, cable outlets inside		-B3	
		Underneath, cable outlets outside		-B4	
		On top	²	-T	
		On top, cable outlets to front		-T1	
		On top, cable outlets to rear		-T2	
		On top, cable outlets inside		-T3	
		On top, cable outlets outside		-T4	
	Controller	Without controller		-	
		With controller, motor and encoder cable (0.5 m)		-E2	
		With controller, motor and encoder cable (1 m)		-E3	
		With controller, motor and encoder cable (1.5 m)		-E4	
		With controller, motor and encoder cable (2 m)		-E5	
	Language of documentation	German		-DE	
		English		-EN	
		Spanish		-ES	
		French		-FR	
		Italian		-IT	
		Russian		-RU	
		Swedish		-SV	
		Chinese		-ZH	

- ¹ **w** The controller E2, E3, E4, E5 is omitted in combination with "Without stepper motors" W
² **B, T** Not in combination with stepper motors ST and SB. Option if third-party motors are mounted

Transfer order code

	EXCM	-	30	-		-		-	KF	-		-		-		-	
--	-------------	---	-----------	---	--	---	--	---	-----------	---	--	---	--	---	--	---	--

Planar surface gantries EXCM

Accessories

Sensor mounting EAPR
(incl. switch lug)

Materials:
Bracket: Wrought aluminium alloy
Switch lug: Steel
RoHS-compliant

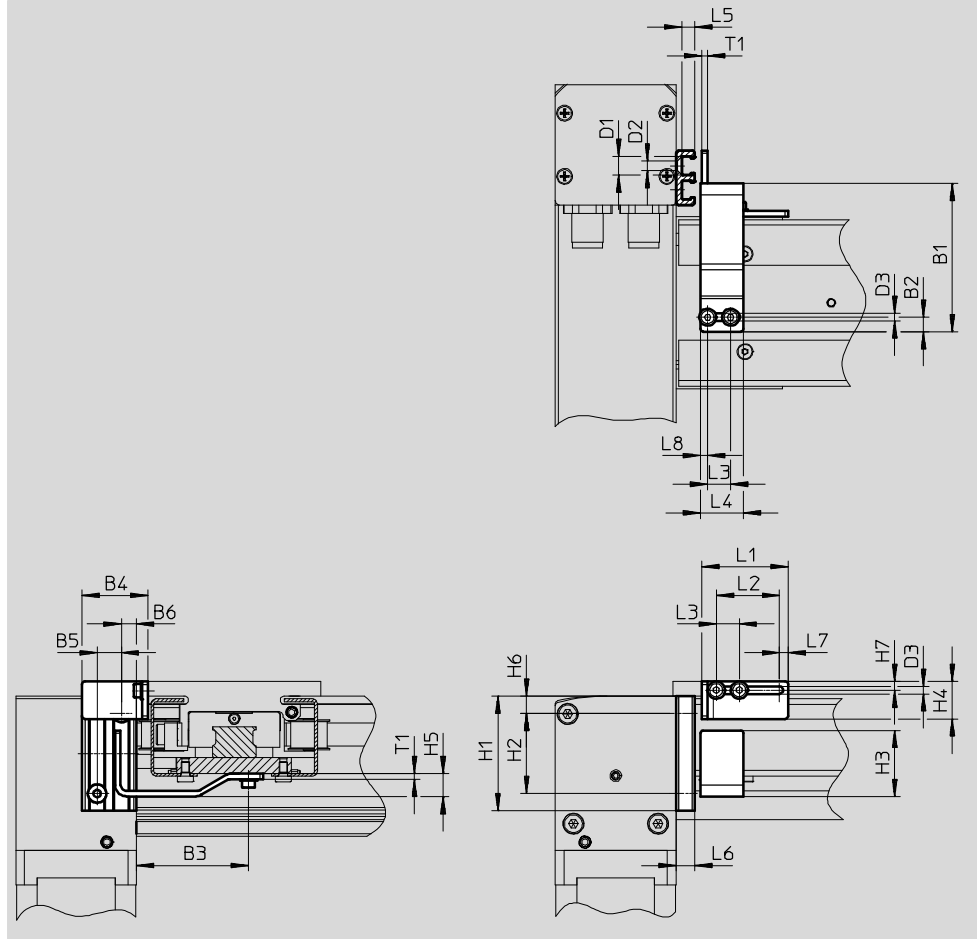

Dimensions and ordering data										
For size	B1	B2	B3	B4	B5	B6	D1	D2	D3	H1
30	51.5	5	39	23	8.4	5.3	∅ 6.5	∅ 3.4	∅ 2.6	40
For size	H2	H3	H4	H5	H6	H7	L1	L2	L3	L4
30	28	23	13	8	6	3	30	22	8	15
For size	L5	L6	L7	L8	T1	Weight [g]	Part No.	Type		
30	4.5	6.5	3	2.5	2	330	2319236	EAPR-E11-30		

Planar surface gantries EXCM

Accessories

Profile mounting MUE

Material:

Anodised aluminium

RoHS-compliant

Scope of delivery:

1 pair

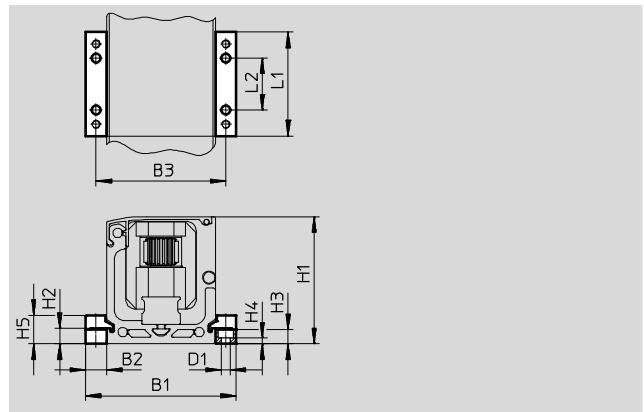

Dimensions and ordering data							
For size	B1	B2	B3	D1 ∅	H1	H2	H3
30	58	8	50	3.4	49	6	5.5

For size	H4	H5	L1	L2	Weight [g]	Part No.	Type
30	2.3	11	40	20	20	558042	MUE-50

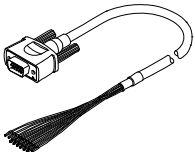
Ordering data – Cables				
	Brief description	Cable length [m]	Part No.	Type
	Control cable, for I/O interface to any controller	1	2307459	NEBC-S1H15-E-1.0-N-LE15
		2.5	2052917	NEBC-S1H15-E-2.5-N-LE15
		5	2052918	NEBC-S1H15-E-5.0-N-LE15
		10	2052919	NEBC-S1H15-E-10.0-N-LE15

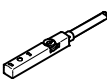
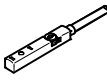
Ordering data – Proximity sensor for T-slot, inductive					Technical data → Internet: sies	
	Type of mounting	Electrical connection	Switching output	Cable length [m]	Part No.	Type
N/O contact						
	Insertable in the slot from above, flush with the cylinder profile	Cable, 3-wire	PNP	7.5	551386	SIES-8M-PS-24V-K-7,5-OE
		Plug M8x1, 3-pin		0.3	551387	SIES-8M-PS-24V-K-0,3-M8D
		Cable, 3-wire	NPN	7.5	551396	SIES-8M-NS-24V-K-7,5-OE
		Plug M8x1, 3-pin		0.3	551397	SIES-8M-NS-24V-K-0,3-M8D
N/C contact						
	Insertable in the slot from above, flush with the cylinder profile	Cable, 3-wire	PNP	7.5	551391	SIES-8M-PO-24V-K-7,5-OE
		Plug M8x1, 3-pin		0.3	551392	SIES-8M-PO-24V-K-0,3-M8D
		Cable, 3-wire	NPN	7.5	551401	SIES-8M-NO-24V-K-7,5-OE
		Plug M8x1, 3-pin		0.3	551402	SIES-8M-NO-24V-K-0,3-M8D