

**Bellows actuator EB**



## Bellows actuator EB

Key features

### Key features

- Suitable for use in harsh, dusty ambient conditions
- Can be used under water
- Sturdy design
- Large forces range from 1 ... 50 KN
- Low installation height
- No stick-slip effect
- Maintenance-free

Bellows actuators function both as driving and pneumatic spring components. Bellows actuators function as a driving component by providing supply and exhaust functions. As the stroke increases, the force generated is reduced in relation to the

contractual force of the bellows. When bellows actuators are supplied with permanent pressure, they act as a cushioning component. The simple design consists of two metal port plates with an attached rubber

bellows. There are no sealing components and no moving mechanical parts. Bellows actuators are single-acting drives that do not require spring returns, as the reset is achieved by the application of external force.

EB-80

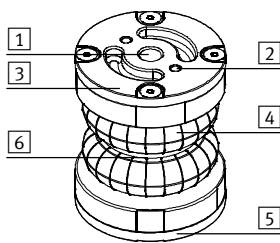

EB-145 ... 385

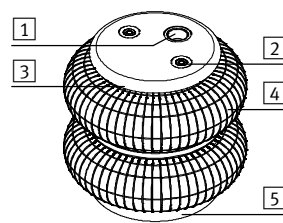

- 1 Pneumatic connection
- 2 Mounting thread
- 3 Port plate, on top
- 4 Bellows
- 5 Port plate, underneath
- 6 Belt ring

### Prerequisites for using a bellows actuator

#### Space required

Observe the installation space to ensure the bellows actuator does not come into contact with other machine parts during expansion.

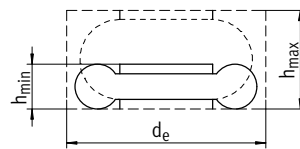

#### Combined installation

When using two or more bellows actuators, the necessary mounting plates must be inserted between the cylinders to prevent a lateral break out.

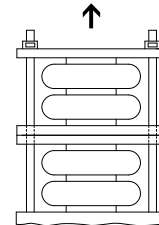

#### Lateral offset

The max. lateral offset must not be exceeded.

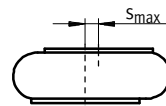

#### Tilted installation

The max. tilt angle  $\alpha$  must not be exceeded to ensure that the bellows walls cannot touch.

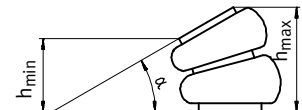

#### Minimum height

The bellows actuator must not fall below a min. height, otherwise it will be damaged.

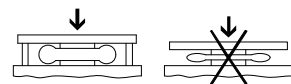

#### Maximum height

The bellows actuator must not exceed a max. height, otherwise it will be damaged.

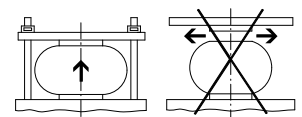

## Bellows actuator EB

Product range overview and type codes

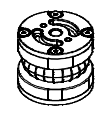
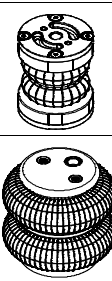
Product range overview						
Function	Feature	Type	Size	Stroke [mm]	Thrust <sup>1)</sup> [kN]	Recommended operating height [mm]
Single-acting		Single-bellows actuator	80	20	1.7	60
			145	60	3.2	90
			165	65	5.7	90
			215	80	8.3	110
			250	85	11.9	110
			325	95	21.8	130
			385	115	31.6	145
		Double-bellows actuator	80	45	1.4	90
			145	100	2.4	160
			165	125	3.8	175
			215	155	8.0	190
			250	185	10.7	210
			325	215	20.6	240
			385	230	31.5	250

1) At recommended operating height and operating pressure of 6 bar

### Type codes

		EB	–	250	–	85
<b>Type</b>						
Single-acting						
EB	Bellows					
<b>Size</b>						
<b>Stroke [mm]</b>						

## Bellows actuator EB

Technical data

**FESTO**

Function



-  - Diameter  
80 ... 385 mm

-  - Stroke length  
20 ... 230 mm

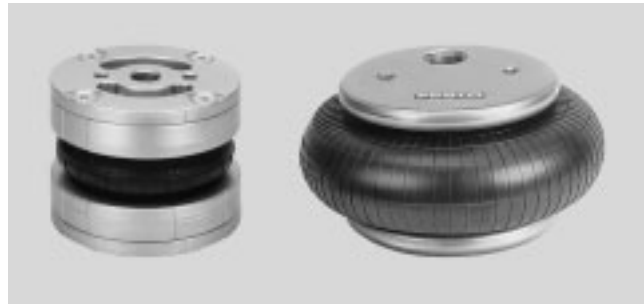

General technical data								
Size	80	145	165	215	250	325	385	
Pneumatic port	G $\frac{1}{4}$	G $\frac{1}{8}$	G $\frac{1}{4}$	G $\frac{3}{4}$	G $\frac{3}{4}$	G $\frac{1}{4}$	G $\frac{1}{4}$	
Stroke								
Single-bellows actuator	[mm]	20	60	65	80	85	95	115
Double-bellows actuator	[mm]	45	100	125	155	185	215	230
Mode of operation	Single-acting							
Type of mounting	Via internal thread							
Mounting position	Any							

Operating and environmental conditions								
Size	80	145	165	215	250	325	385	
Operating medium	Compressed air to ISO 8573-1:2010 [---:4]							
Note on the operating/control medium <sup>1)</sup>	Lubricated operation not possible							
Operating pressure	[bar]	0 ... 8						
Ambient temperature	[°C]	-40 ... +70						
Corrosion resistance class CRC <sup>2)</sup>	0	2						

1) Additional operating media on request

2) Corrosion resistance class CRC 0 to Festo standard FN 940070

No corrosion stress. Applies to small, optically irrelevant standard parts such as threaded pins, circlips and clamping sleeves which are usually only available in a phosphated or burnished version (and possibly oiled) as well as to ball bearings (for components < CRC 3) and plain bearings.

Corrosion resistance class CRC 2 to Festo standard FN 940070

Moderate corrosion stress. Indoor applications in which condensation may occur. External visible parts with primarily decorative requirements for the surface and which are in direct contact with the ambient atmosphere typical for industrial applications.

Weight [g]								
Size	80	145	165	215	250	325	385	
Single-bellows actuator	500	900	1200	2000	2300	4100	5900	
Double-bellows actuator	500	1100	1500	2300	3000	4800	6900	

## Bellows actuator EB

Technical data

### Materials

Sectional view

EB-80

EB-145 ... 385

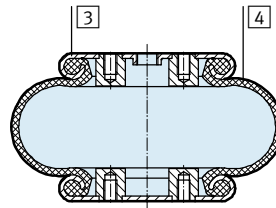
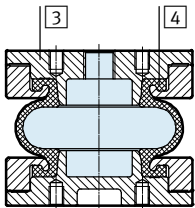

Size	80	145	165	215	250	325	385
3 Housing	Die-cast aluminium		Galvanised steel				
4 Bellows	CR	NR/BR					
- Note on materials	Free of copper and PTFE						
	RoHS-compliant						

Forces [N]							
Size	80	145	165	214	250	325	385
Single-bellows actuator							
Force/stroke characteristics	→ 6						
Resetting force	400	120	200	200	200	300	300
Double-bellows actuator							
Force/stroke characteristics	→ 8						
Resetting force	200	200	200	200	200	300	400

### Note

- Bellows actuators may only be driven against a workpiece, or they must be equipped with stroke limiting stops at the stroke ends, because the bellows walls would otherwise be overloaded or internal damage could occur.
- A resetting force is required to press the bellows actuator together to its minimum height. As a rule, this is achieved through the weight force
- The entire bearing surfaces of the upper and lower plates must be utilised to absorb forces
- Bellows actuators must be exhausted before disassembly
- The walls of bellows actuators must not come into contact with other parts during operation

# Bellows actuator EB

Technical data

## Thrust F and bellows volume V as a function of the stroke length H

The diagram illustrates the change in thrust F with various working pressures and differing bellows volumes V in relation to the stroke

length. The minimum installation height  $H_{min}$  must be observed to fully reach the indicated forces.

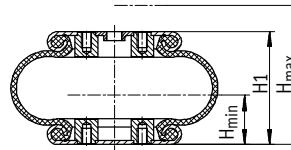

### Single-bellows actuator

EB-80-20

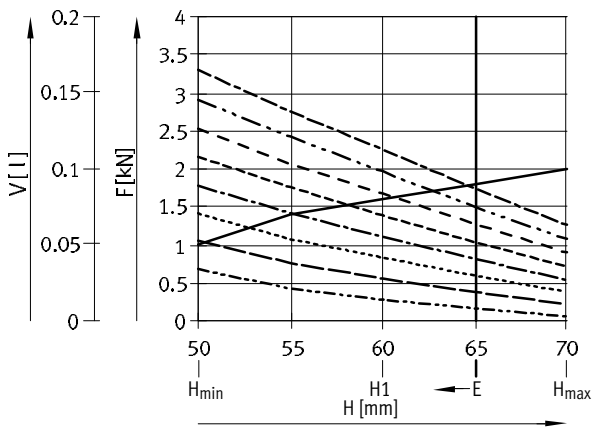

EB-145-60

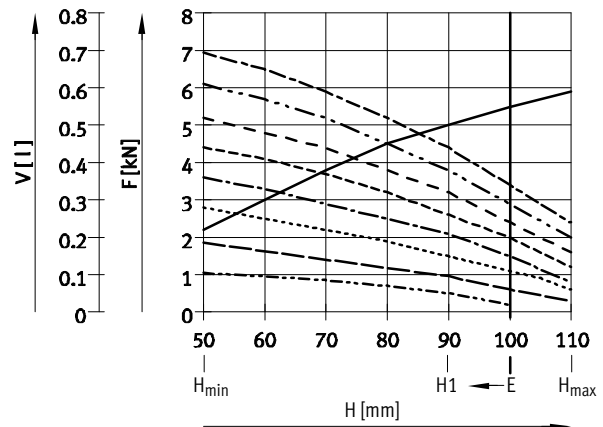

EB-165-65

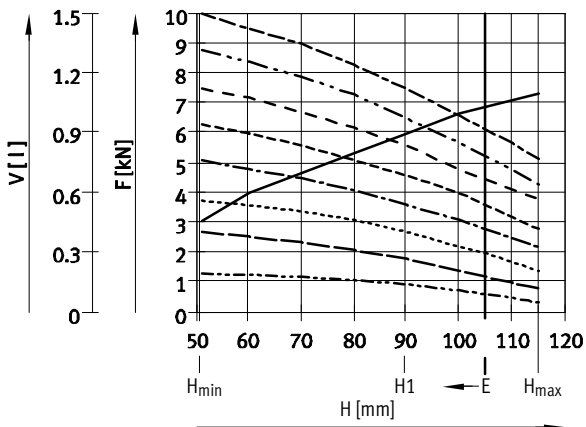

EB-215-80

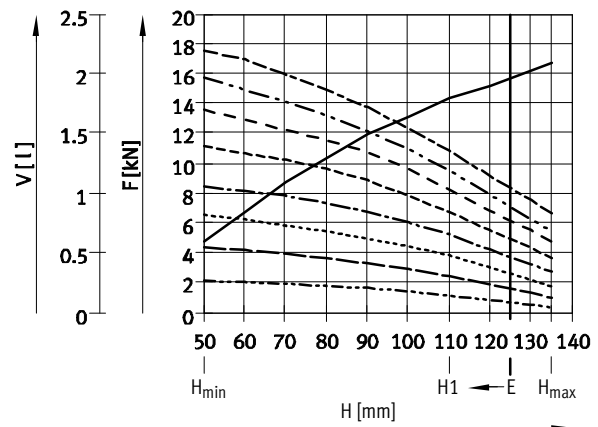

H1 Recommended operating height for cushioning application at 6 bar

$H_{min}$  Min. installation height  
 $H_{max}$  Max. extended height

← E Preferred range of application: Outside this range, the force reduces to a level so that the use of the next largest size is recommended.

— Volume  
- - - 1 bar  
- · - 2 bar  
- · - · 3 bar  
- · - · - 4 bar  
- · - · - · 5 bar

- - - 6 bar  
- · - 7 bar  
- · - · 8 bar

# Bellows actuator EB

Technical data

## Thrust F and bellows volume V as a function of the stroke length H

The diagram illustrates the change in thrust F with various working pressures and differing bellows volumes V in relation to the stroke length. The minimum installation height  $H_{min}$  must be observed to fully reach the indicated forces.

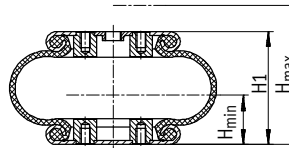

### Single-bellows actuator

EB-250-85

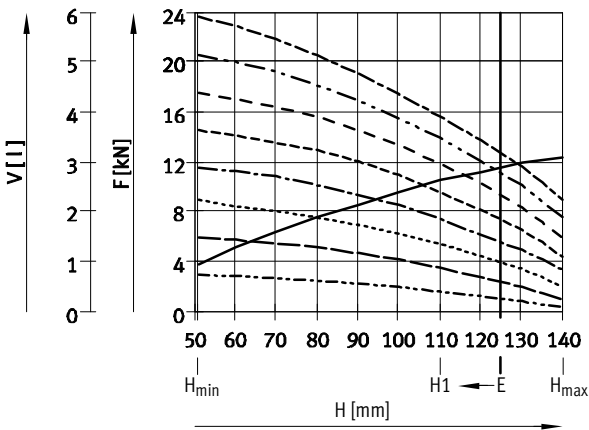

EB-325-95

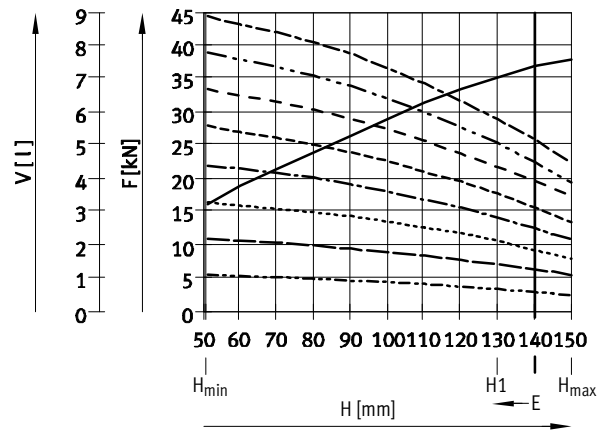

EB-385-115

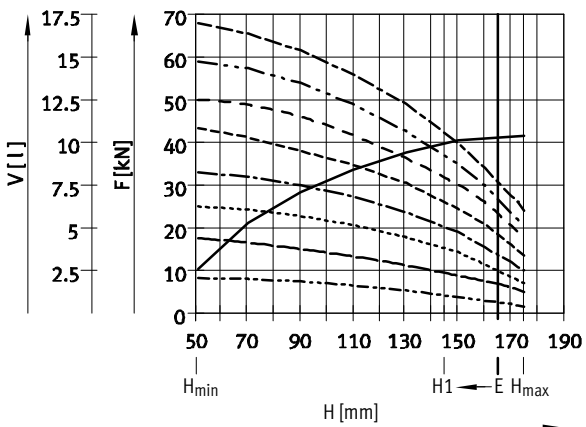

H1 Recommended operating height for cushioning application at 6 bar  
 $H_{min}$  Min. installation height  
 $H_{max}$  Max. extended height

← E Preferred range of application:  
 Outside this range, the force reduces to a level so that the use of the next largest size is recommended.

— Volume  
 ..... 1 bar  
 - - - 2 bar  
 ..... 3 bar  
 - - - 4 bar  
 - - - 5 bar  
 - - - 6 bar  
 - - - 7 bar  
 - - - 8 bar

# Bellows actuator EB

Technical data

## Thrust F and bellows volume V as a function of the stroke length H

The diagram illustrates the change in thrust F with various working pressures and differing bellows volumes V in relation to the stroke

length. The minimum installation height  $H_{min}$  must be observed to fully reach the indicated forces.

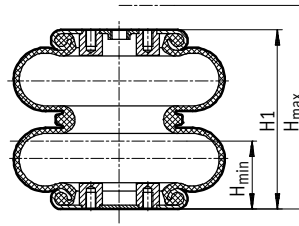

### Double-bellows actuator

EB-80-45

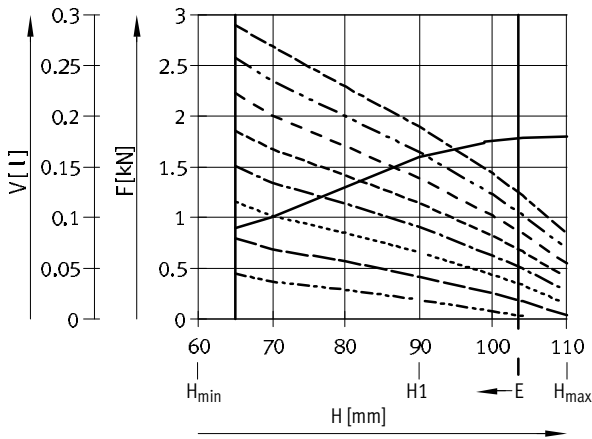

EB-145-100

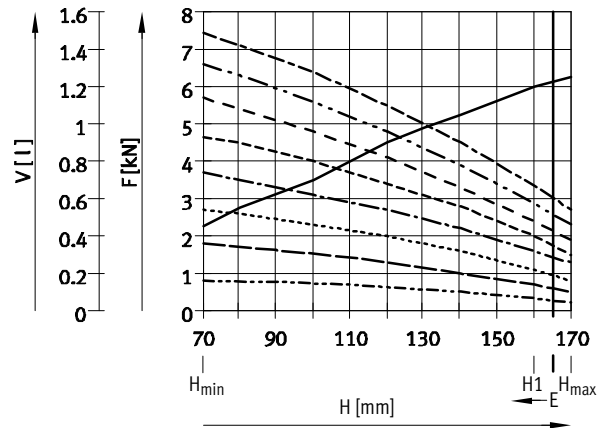

EB-165-125

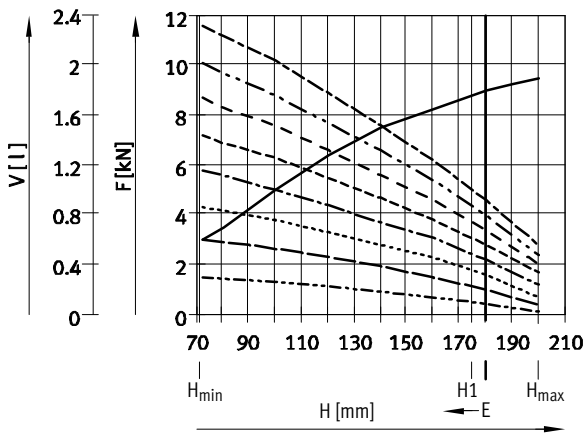

EB-215-155

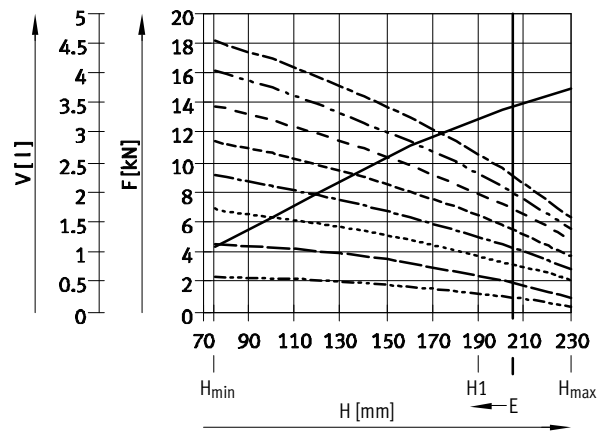

H1 Recommended operating height for cushioning application at 6 bar  
 $H_{min}$  Min. installation height  
 $H_{max}$  Max. extended height

← E Preferred range of application:  
 Outside this range, the force reduces to a level so that the use of the next largest size is recommended.

— Volume  
 - - - 1 bar  
 - - - 2 bar  
 - - - 3 bar  
 - - - 4 bar  
 - - - 5 bar

- - - 6 bar  
 - - - 7 bar  
 - - - 8 bar



# Bellows actuator EB

Technical data

## Thrust F and bellows volume V as a function of the stroke length H

The diagram illustrates the change in thrust F with various working pressures and differing bellows volumes V in relation to the stroke length. The minimum installation height  $H_{min}$  must be observed to fully reach the indicated forces.

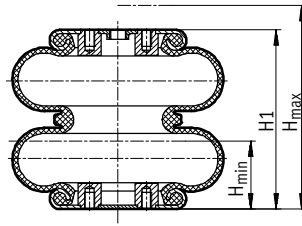

### Double-bellows actuator

EB-250-185

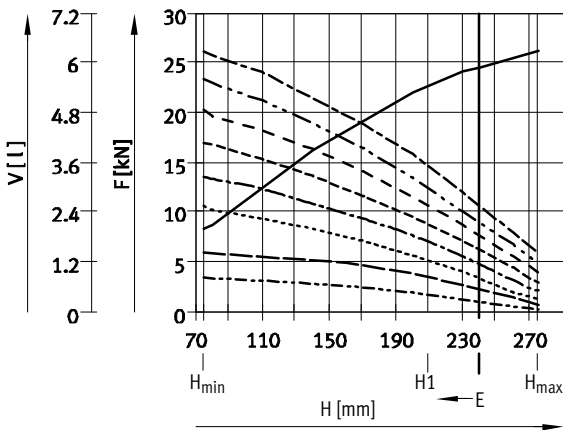

EB-325-215

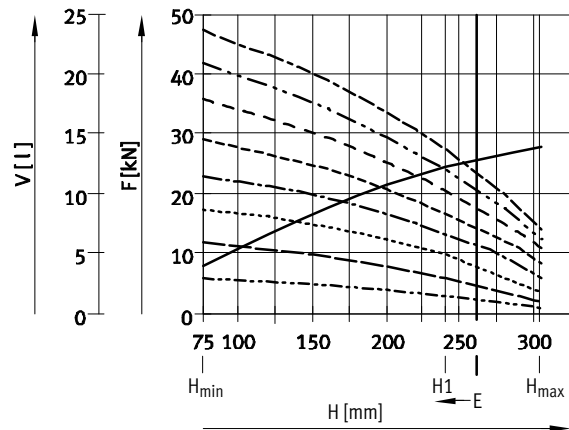

EB-385-230

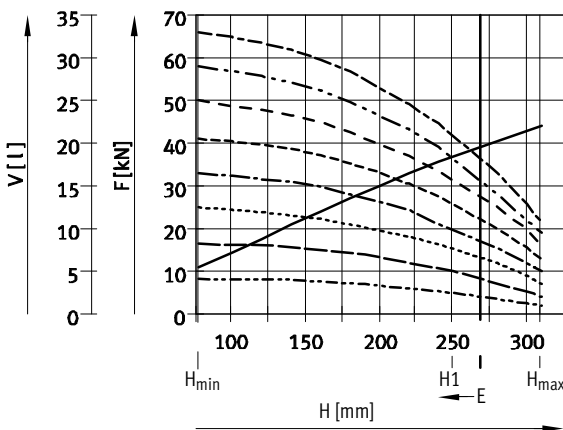

H1 Recommended operating height for cushioning application at 6 bar  
 $H_{min}$  Min. installation height  
 $H_{max}$  Max. extended height

← E Preferred range of application: Outside this range, the force reduces to a level so that the use of the next largest size is recommended.

- |           |        |       |       |           |       |
|-----------|--------|-------|-------|-----------|-------|
| —         | Volume | ----- | 3 bar | ---       | 6 bar |
| - - - - - | 1 bar  | ----- | 4 bar | - - - - - | 7 bar |
| - - - - - | 2 bar  | ----- | 5 bar | -----     | 8 bar |

## Bellows actuator EB

Technical data

### Dimensions

Download CAD data → [www.festo.com](http://www.festo.com)

Single-bellows actuator – EB-80

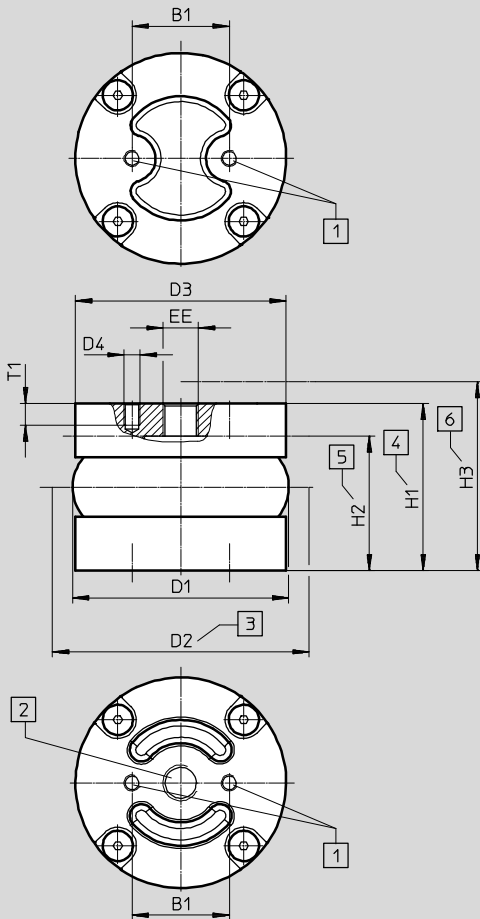

Max. offset between mounting surfaces:

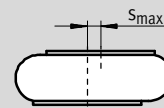

The stroke of the bellows actuator can be made to carry out a circular path, in which case the indicated tilt angle  $\alpha$  must not be exceeded. During setup it must be ensured that the minimum height  $H_{min}$  is observed, and that the maximum height  $H_{max}$  is not exceeded at any given point.

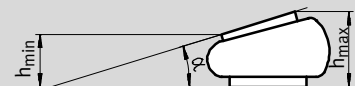

- |                               |                                |
|-------------------------------|--------------------------------|
| 1 Fastening thread            | 4 Recommended operating height |
| 2 Supply port                 | 5 Min. installation height     |
| 3 Required installation space | 6 Max. extended height         |

Type	B1	D1 ∅ max.	D2 ∅	D3 ∅	D4	EE
EB-80-20	36	80	95	78	M6	G1/4

Type	H1	H2 Min.	H3 Max.	T1 Min.	S <sub>max</sub>	Tilt angle $\alpha$ max.
EB-80-20	60	50	70	8	5	10°

# Bellows actuator EB

Technical data

## Dimensions

Download CAD data → [www.festo.com](http://www.festo.com)

Single-bellows actuator – EB-145 ... 385

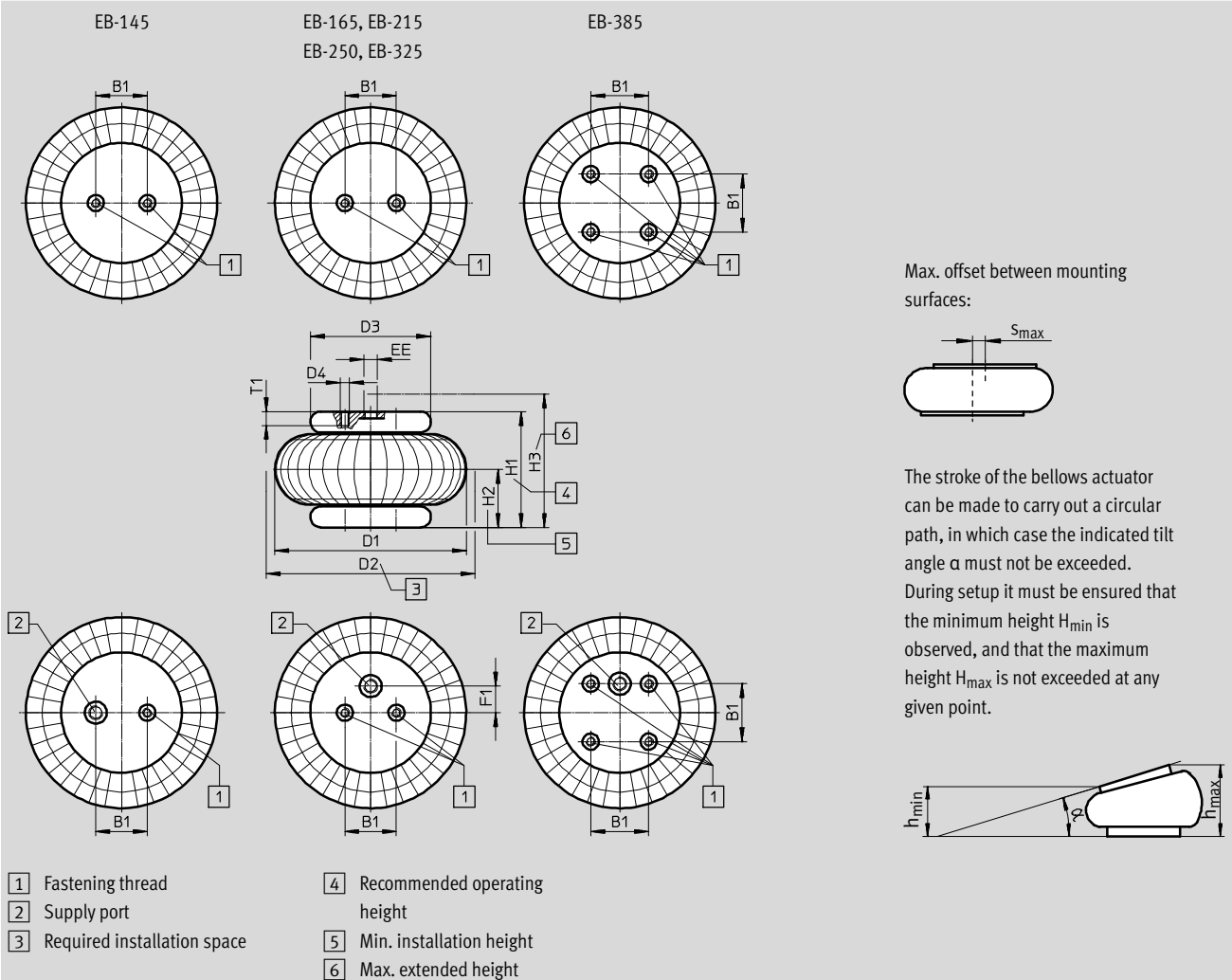

Type	B1 ±0.2	D1 ∅ max.	D2 ∅	D3 ∅	D4	EE	F1 ±0.2
EB-145-60	20	145	160	90	M8	G1/8	–
EB-165-65	44.5	165	180	108	M8	G1/4	0
EB-215-80	70	215	230	141	M8	G3/4	0
EB-250-85	89	250	265	161	M8	G3/4	38.1
EB-325-95	157.5	325	340	228	M8	G1/4	73
EB-385-115	158.8	385	400	287	M8	G1/4	79.4

Type	H1	H2 Min.	H3 Max.	T1 Min.	$S_{max}$	Tilt angle $\alpha$ max.
EB-145-60	90	50	110	15	10	20°
EB-165-65	90	51	115	15	10	20°
EB-215-80	110	50	135	15	10	20°
EB-250-85	110	51	140	15	10	20°
EB-325-95	130	51	150	15	10	15°
EB-385-115	145	51	175	15	10	15°

## Bellows actuator EB

Technical data

### Dimensions

Download CAD data → [www.festo.com](http://www.festo.com)

Double-bellows actuator – EB-80

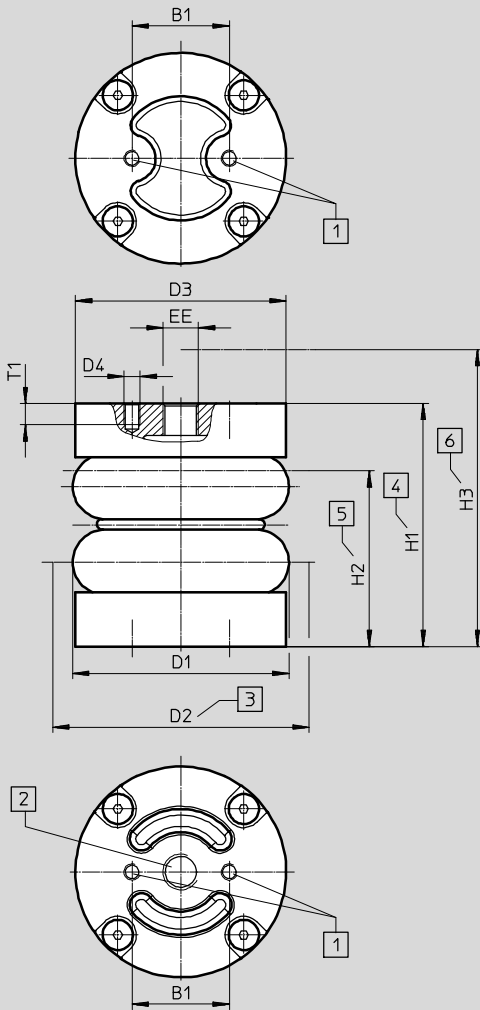

- |                               |                                |
|-------------------------------|--------------------------------|
| 1 Fastening thread            | 4 Recommended operating height |
| 2 Supply port                 | 5 Min. installation height     |
| 3 Required installation space | 6 Max. extended height         |

Max. offset between mounting surfaces:

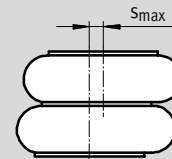

The stroke of the bellows actuator can be made to carry out a circular path, in which case the indicated tilt angle  $\alpha$  must not be exceeded. During setup it must be ensured that the minimum height  $h_{\min}$  is observed, and that the maximum height  $h_{\max}$  is not exceeded at any given point.

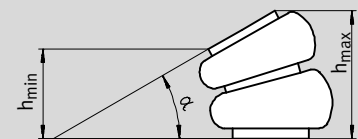

Type	B1	D1 ∅ max.	D2 ∅	D3 ∅	D4	EE
EB-80-45	36	80	95	78	M6	G1/4

Type	H1	H2 Min.	H3 Max.	T1 Min.	S <sub>max</sub>	Tilt angle $\alpha$ max.
EB-80-45	90	65	110	8	10	15°

# Bellows actuator EB

Technical data

## Dimensions

Download CAD data → [www.festo.com](http://www.festo.com)

Double-bellows actuator – EB-145 ... 385

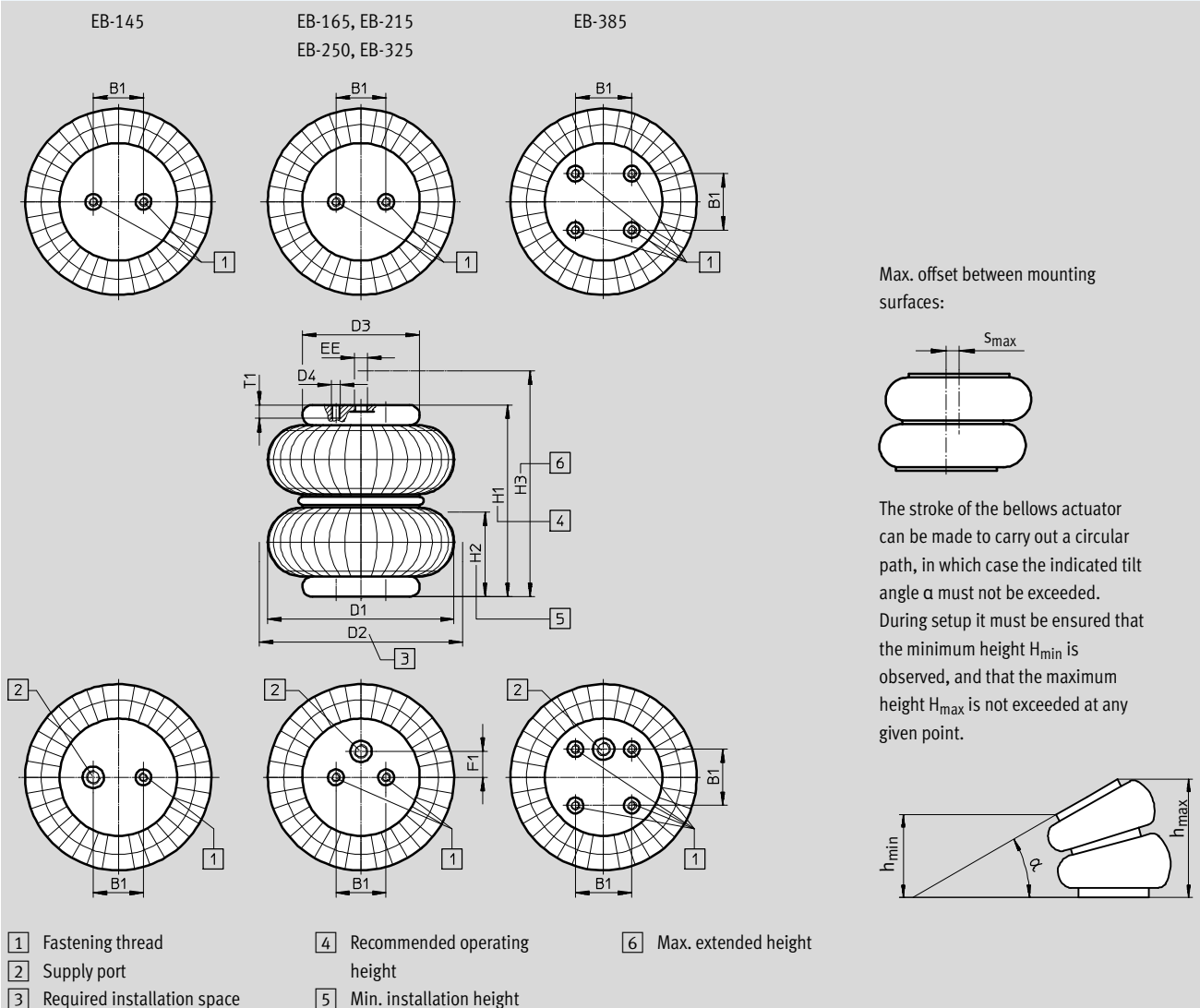





Type	B1	D1 ∅ max.	D2 ∅	D3 ∅	D4	EE	F1 ±0.2
EB-145-100	20	145	160	90	M8	G $\frac{1}{8}$	–
EB-165-125	44.5	165	180	108	M8	G $\frac{1}{4}$	0
EB-215-155	70	215	230	141	M8	G $\frac{3}{4}$	0
EB-250-185	89	250	265	161	M8	G $\frac{3}{4}$	38.1
EB-325-215	157.5	325	340	228	M8	G $\frac{1}{4}$	73
EB-385-230	158.8	385	400	287	M8	G $\frac{1}{4}$	79.4

Type	H1	H2 Min.	H3 Max.	T1 Min.	S <sub>max</sub>	Tilt angle $\alpha$ max.
EB-145-100	160	70	170	15	20	30°
EB-165-125	175	72	200	15	20	30°
EB-215-155	190	75	230	15	20	30°
EB-250-185	210	75	275	15	20	25°
EB-325-215	240	75	305	15	20	20°
EB-385-230	250	77	310	15	20	20°

## Bellows actuator EB

Technical data

Ordering data				
Type	Size	Stroke [mm]	Part No.	Type
Single-bellows actuator				
	80	20	<b>2748903</b>	<b>EB-80-20</b>
	145	60	<b>36486</b>	<b>EB-145-60</b>
	165	65	<b>36487</b>	<b>EB-165-65</b>
	215	80	<b>36488</b>	<b>EB-215-80</b>
	250	85	<b>36489</b>	<b>EB-250-85</b>
	325	95	<b>193788</b>	<b>EB-325-95</b>
	385	115	<b>193789</b>	<b>EB-385-115</b>
Double-bellows actuator				
	80	45	<b>2748904</b>	<b>EB-80-45</b>
	145	100	<b>36490</b>	<b>EB-145-100</b>
	165	125	<b>36491</b>	<b>EB-165-125</b>
	215	155	<b>36492</b>	<b>EB-215-155</b>
	250	185	<b>36493</b>	<b>EB-250-185</b>
	325	215	<b>193790</b>	<b>EB-325-215</b>
	385	230	<b>193791</b>	<b>EB-385-230</b>