

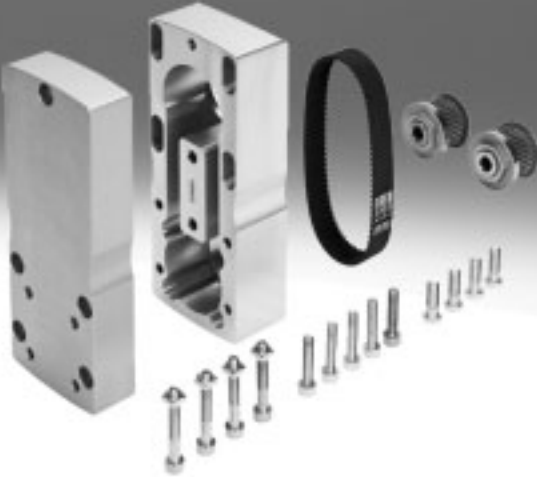







Parallel kits EAMM-U

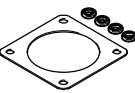

# Parallel kits EAMM-U

Features

<b>At a glance</b>			
Parallel kits EAMM-U		→ 11	
	<ul style="list-style-type: none"> <li>• Increased housing rigidity</li> <li>• More flexible motor mounting possible</li> <li>• Larger toothed belt bending radii for improved service life</li> </ul>	<ul style="list-style-type: none"> <li>• Optionally with degree of protection to IP65</li> <li>• Use in combination with third-party motors on request</li> </ul>	
<b>Clamping component EADT</b>		→ 28	
	For adjusting the toothed belt pretension with EAMM-U-110 and EAMM-U-145. The motor is pushed away from the	axis mechanism by turning the clamping component secured in a hole in the housing (the motor can be moved in a slot for this purpose). This	enables high toothed belt pretension forces to be generated with low torques at the clamping component.
<b>Counter bearing EAMG</b>		→ 28	
	A counter bearing EAMG reduces the load on the axis or motor bearings to improve the service life under high	loads. A clamping sleeve EAMH-...-P is additionally required for each counter bearing.	
<b>Clamping sleeve EAMH-...-P</b>		→ 29	
	To retrofit the counter bearing, the clamping sleeve without trunnion included as standard in the parallel kit	must be replaced by the clamping sleeve EAMH-...-P with integrated trunnion.	
<b>Clamping sleeve EAMH-...</b>		→ 30	
	Clamping sleeves for adapting third-party motors with deviating shaft diameters on the parallel kits.		
<b>Seal set EADS-F-...</b>		→ 31	
	Spare part for sealed parallel kit EAMM-U-...-S1, between motor and kit.		
<b>Parallel kits EAMM-U</b>		→ 11	
	<ul style="list-style-type: none"> <li>• Space-saving gravity die-cast housing</li> </ul>		
<p> Note</p> <p>Depending on the combination of motor and drive, it may not be possible to reach the maximum feed force of the drive in certain circumstances. The respective no-load driving torque of the kit must be taken into consideration when using parallel kits.</p> <p style="text-align: right;">PositioningDrives sizing software <a href="http://www.festo.com">www.festo.com</a></p>			

# Parallel kits EAMM-U

Product range overview



## Permissible axis/motor combinations with electric cylinder DNCE

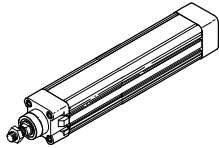

### Features of the kits

- Increased housing rigidity
- More flexible motor mounting possible
- Larger toothed belt bending radii for improved service life
- Use in combination with third-party motors on request

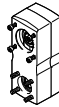

Motor/gear unit <sup>2)</sup>	Parallel kit	
Type	Part No.	Type
<b>DNCE-32</b>		
With servo motor		
EMME-AS-40-...	2153283	EAMM-U-50-D32-40P-78
	2154009	EAMM-U-50-D32-40P-78-S1 <sup>1)</sup>
EMMS-AS-40-...	1201591	EAMM-U-50-D32-40A-78
	1202302	EAMM-U-50-D32-40A-78-S1 <sup>1)</sup>
EMMS-AS-55-...	1210126	EAMM-U-60-D32-55A-91
	1210450	EAMM-U-60-D32-55A-91-S1 <sup>1)</sup>
EMME-AS-60-...	2619586	EAMM-U-70-D32-60P-96
	2619688	EAMM-U-70-D32-60P-96-S1 <sup>1)</sup>
EMMS-AS-70-...	2755565	EAMM-U-70-D32-70A-96
	2781711	EAMM-U-70-D32-70A-96-S1 <sup>1)</sup>
With stepper motor		
EMMS-ST-42-...	1201607	EAMM-U-50-D32-42A-78
	1202312	EAMM-U-50-D32-42A-78-S1 <sup>1)</sup>
EMMS-ST-57-...	1210419	EAMM-U-60-D32-57A-91
	1210453	EAMM-U-60-D32-57A-91-S1 <sup>1)</sup>
With motor unit		
MTR-DCI-32S-...	1570862	EAMM-U-50-D32-32B-78
MTR-DCI-42S-...	1577393	EAMM-U-60-D32-42B/C-91
	1577380	EAMM-U-60-D32-42B/C-91-S1 <sup>1)</sup>
MTR-DCI-52S-...	2755890	EAMM-U-70-D32-52B/C-96
	2781778	EAMM-U-70-D32-52B/C-96-S1 <sup>1)</sup>
With gear unit		
EMGA-40-P-...	1577358	EAMM-U-60-D32-40G-91
EMGC-40-P-...	1577346	EAMM-U-60-D32-40G-91-S1 <sup>1)</sup>
EMGA-60-P-...-SAS/ SST <sup>3)</sup>	2748181	EAMM-U-70-D32-60G-96
	2778302	EAMM-U-70-D32-60G-96-S1 <sup>1)</sup>
EMGA-60-P-...-EAS, EMGC-60-P-... <sup>3)</sup>	2778393	EAMM-U-70-D32-60H-96
	2781450	EAMM-U-70-D32-60H-96-S1 <sup>1)</sup>

Motor/gear unit <sup>2)</sup>	Parallel kit	
Type	Part No.	Type
<b>DNCE-40</b>		
With servo motor		
EMMS-AS-55-...	1210438	EAMM-U-60-D40-55A-91
	1210458	EAMM-U-60-D40-55A-91-S1 <sup>1)</sup>
EMME-AS-60-...	2617488	EAMM-U-70-D40-60P-96
	2546123	EAMM-U-70-D40-60P-96-S1 <sup>1)</sup>
EMMS-AS-70-...	2786204	EAMM-U-70-D40-70A-96
	2786316	EAMM-U-70-D40-70A-96-S1 <sup>1)</sup>
EMMS-AS-70-...	1212826	EAMM-U-86-D40-70A-102
	1212854	EAMM-U-86-D40-70A-102-S1 <sup>1)</sup>
EMME-AS-80-...	2802441	EAMM-U-86-D40-80P-102
	2802656	EAMM-U-86-D40-80P-102-S1 <sup>1)</sup>
With stepper motor		
EMMS-ST-57-...	1210442	EAMM-U-60-D40-57A-91
	1210462	EAMM-U-60-D40-57A-91-S1 <sup>1)</sup>
EMMS-ST-87-...	1215802	EAMM-U-86-D40-87A-102
	1215814	EAMM-U-86-D40-87A-102-S1 <sup>1)</sup>
With motor unit		
MTR-DCI-42S-...	1570950	EAMM-U-60-D40-42B/C-91
	1430735	EAMM-U-60-D40-42B/C-91-S1 <sup>1)</sup>
MTR-DCI-52S-...	2786802	EAMM-U-70-D40-52B/C-96
	2786845	EAMM-U-70-D40-52B/C-96-S1 <sup>1)</sup>
MTR-DCI-52S-...	1537046	EAMM-U-86-D40-52B/C-102
	1537011	EAMM-U-86-D40-52B/C-102-S1 <sup>1)</sup>
With gear unit		
EMGA-40-P-...	1577165	EAMM-U-60-D40-40G-91
EMGC-40-P-...	1435968	EAMM-U-60-D40-40G-91-S1 <sup>1)</sup>
EMGA-60-P-...-SAS/ SST <sup>3)</sup> ...	2785471	EAMM-U-70-D40-60G-96
	2785542	EAMM-U-70-D40-60G-96-S1 <sup>1)</sup>
EMGA-60-P-...-EAS, EMGC-60-P-... <sup>3)</sup>	2786101	EAMM-U-70-D40-60H-96
	2786137	EAMM-U-70-D40-60H-96-S1 <sup>1)</sup>
EMGA-60-P-...-SAS/ SST <sup>3)</sup>	1586445	EAMM-U-86-D40-60G-102
	1586429	EAMM-U-86-D40-60G-102-S1 <sup>1)</sup>
EMGA-60-P-...-EAS, EMGC-60-P-... <sup>3)</sup>	1586496	EAMM-U-86-D40-60H-102
	1586372	EAMM-U-86-D40-60H-102-S1 <sup>1)</sup>

1) With degree of protection IP65

2) The input torque must not exceed the max. perm. transferable torque of the parallel kit.

3) Gear unit drive shaft  $\varnothing$ : EMGA-60-P-...-SAS/-SST: 11 mm; EMGA-60-P-...-EAS, EMGC-60-P-...: 14 mm

# Parallel kits EAMM-U

Product range overview



## Permissible axis/motor combinations with electric cylinder DNCE

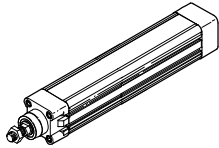

### Features of the kits

- Increased housing rigidity
- More flexible motor mounting possible
- Larger toothed belt bending radii for improved service life
- Use in combination with third-party motors on request

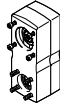

Motor/gear unit <sup>2)</sup>	Parallel kit	
Type	Part No.	Type
<b>DNCE-63</b>		
With servo motor		
EMMS-AS-70-...	1212477	EAMM-U-86-D60-70A-102
	1212835	EAMM-U-86-D60-70A-102-S1 <sup>1)</sup>
EMME-AS-80-...	2155875	EAMM-U-86-D60-80P-102
	2156527	EAMM-U-86-D60-80P-102-S1 <sup>1)</sup>
EMME-AS-100-...	1202436	EAMM-U-110-D60-100A-120
	1203112	EAMM-U-110-D60-100A-120-S1 <sup>1)</sup>
EMMS-AS-100-...	1202436	EAMM-U-110-D60-100A-120
	1203112	EAMM-U-110-D60-100A-120-S1 <sup>1)</sup>
With stepper motor		
EMMS-ST-87-...	1215784	EAMM-U-86-D60-87A-102
	1215810	EAMM-U-86-D60-87A-102-S1 <sup>1)</sup>
With motor unit		
MTR-DCI-52S-...	1537000	EAMM-U-86-D60-52B/C-102
	1431381	EAMM-U-86-D60-52B/C-102-S1 <sup>1)</sup>
MTR-DCI-62S-...	1536988	EAMM-U-110-D60-62B-120
	1431443	EAMM-U-110-D60-62B-120-S1 <sup>1)</sup>
With gear unit		
EMGA-60-P-...-SAS/ SST <sup>3)</sup>	1586347	EAMM-U-86-D60-60G-102
	1437163	EAMM-U-86-D60-60G-102-S1 <sup>1)</sup>
EMGA-60-P-...-EAS, EMGC-60-P-... <sup>3)</sup>	1586276	EAMM-U-86-D60-60H-102
	1530837	EAMM-U-86-D60-60H-102-S1 <sup>1)</sup>
EMGA-60-P-...-SAS/ SST <sup>3)</sup>	1543240	EAMM-U-110-D60-60G-120
	1436183	EAMM-U-110-D60-60G-120-S1 <sup>1)</sup>
EMGA-60-P-...-EAS, EMGC-60-P-... <sup>3)</sup>	1542264	EAMM-U-110-D60-60H-120
	1530621	EAMM-U-110-D60-60H-120-S1 <sup>1)</sup>
EMGA-80-P-...	1532949	EAMM-U-110-D60-80G-120
	1530875	EAMM-U-110-D60-80G-120-S1 <sup>1)</sup>

1) With degree of protection IP65

2) The input torque must not exceed the max. perm. transferable torque of the parallel kit.

3) Gear unit drive shaft  $\varnothing$ : EMGA-60-P-...-SAS/-SST: 11 mm; EMGA-60-P-...-EAS, EMGC-60-P: 14 mm

- - Note

Clamping component EADT for adjusting the toothed belt pretension with EAMM-U-110 → 28

### Features of the kits

- Space-saving gravity die-cast housing



Motor	Parallel kit	
Type	Part No.	Type
<b>DNCE-32</b>		
With servo motor		
EMMS-AS-40-...	543150	EAMM-U-D32-40A
With motor unit		
MTR-DCI-32S-...	543152	EAMM-U-D32-32B
<b>DNCE-40</b>		
With servo motor		
EMMS-AS-55-...	543157	EAMM-U-D40-55A
With motor unit		
MTR-DCI-42S-...-G7	543159	EAMM-U-D40-42B
MTR-DCI-42S-...-G14	543160	EAMM-U-D40-42C
<b>DNCE-63</b>		
With servo motor		
EMMS-AS-70-...	543165	EAMM-U-D60-70A
With motor unit		
MTR-DCI-52S-...-G7	543167	EAMM-U-D60-52B
MTR-DCI-52S-...-G14	543168	EAMM-U-D60-52C

# Parallel kits EAMM-U

Product range overview

## Permissible axis/motor combinations with mini slide EGSL

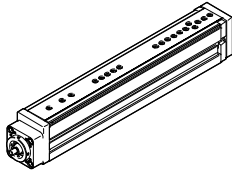

### Features of the kits

- Increased housing rigidity
- More flexible motor mounting possible
- Larger toothed belt bending radii for improved service life
- Use in combination with third-party motors on request

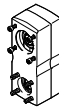

Motor/gear unit <sup>1)</sup>	Parallel kit	
Type	Part No.	Type
<b>EGSL-45</b>		
With servo motor		
EMME-AS-40-...	2153283	EAMM-U-50-D32-40P-78
EMMS-AS-40-...	1201591	EAMM-U-50-D32-40A-78
EMMS-AS-55-...	1210126	EAMM-U-60-D32-55A-91
EMME-AS-60-...	2619586	EAMM-U-70-D32-60P-96
With stepper motor		
EMMS-ST-42-...	1201607	EAMM-U-50-D32-42A-78
EMMS-ST-57-...	1210419	EAMM-U-60-D32-57A-91
With motor unit		
MTR-DCI-32S-...	1570862	EAMM-U-50-D32-32B-78
MTR-DCI-42S-...	1577393	EAMM-U-60-D32-42B/C-91
With gear unit		
EMGA-40-P-...	1577358	EAMM-U-60-D32-40G-91
EMGC-40-P-...		
EMGA-60-P-...-SAS/ SST <sup>2)</sup>	2748181	EAMM-U-70-D32-60G-96
EMGA-60-P-...-EAS, EMGC-60-P-... <sup>2)</sup>	2778393	EAMM-U-70-D32-60H-96

Motor/gear unit <sup>1)</sup>	Parallel kit	
Type	Part No.	Type
<b>EGSL-55</b>		
With servo motor		
EMMS-AS-55-...	1210438	EAMM-U-60-D40-55A-91
EMME-AS-60-...	2617488	EAMM-U-70-D40-60P-96
EMMS-AS-70-...	2786204	EAMM-U-70-D40-70A-96
EMMS-AS-70-...	1212826	EAMM-U-86-D40-70A-102
With stepper motor		
EMMS-ST-57-...	1210442	EAMM-U-60-D40-57A-91
EMMS-ST-87-...	1215802	EAMM-U-86-D40-87A-102
With motor unit		
MTR-DCI-42S-...	1570950	EAMM-U-60-D40-42B/C-91
MTR-DCI-52S-...	2786802	EAMM-U-70-D40-52B/C-96
MTR-DCI-52S-...	1537046	EAMM-U-86-D40-52B/C-102
With gear unit		
EMGA-40-P-...	1577165	EAMM-U-60-D40-40G-91
EMGC-40-P-...		
EMGA-60-P-...-SAS/ SST <sup>2)</sup>	2785471	EAMM-U-70-D40-60G-96
EMGA-60-P-...-EAS, EMGC-60-P-... <sup>2)</sup>	2786101	EAMM-U-70-D40-60H-96
EMGA-60-P-...-SAS/ SST <sup>2)</sup>	1586445	EAMM-U-86-D40-60G-102
EMGA-60-P-...-EAS, EMGC-60-P-... <sup>2)</sup>	1586496	EAMM-U-86-D40-60H-102

1) The input torque must not exceed the max. perm. transferable torque of the parallel kit.

2) Gear unit drive shaft Ø: EMGA-60-P-...-SAS/-SST: 11 mm; EMGA-60-P-...-EAS, EMGC-60-P-...: 14 mm

# Parallel kits EAMM-U

Product range overview



## Permissible axis/motor combinations with mini slide EGSL

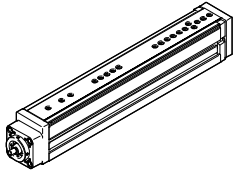

### Features of the kits

- Increased housing rigidity
- More flexible motor mounting possible
- Larger toothed belt bending radii for improved service life
- Use in combination with third-party motors on request

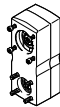

Motor/gear unit <sup>1)</sup>	Parallel kit	
Type	Part No.	Type
<b>EGSL-75</b>		
With servo motor		
<b>EMMS-AS-70-...</b>	<b>1212477</b>	<b>EAMM-U-86-D60-70A-102</b>
<b>EMME-AS-80-...</b>	<b>2155875</b>	<b>EAMM-U-86-D60-80P-102</b>
With stepper motor		
<b>EMMS-ST-87-...</b>	<b>1215784</b>	<b>EAMM-U-86-D60-87A-102</b>
With motor unit		
<b>MTR-DCI-52S-...</b>	<b>1537000</b>	<b>EAMM-U-86-D60-52B/C-102</b>
<b>MTR-DCI-62S-...</b>	<b>1536988</b>	<b>EAMM-U-110-D60-62B-120</b>
With gear unit		
<b>EMGA-60-P-...-SAS/SST<sup>2)</sup></b>	<b>1586347</b>	<b>EAMM-U-86-D60-60G-102</b>
<b>EMGA-60-P-...-EAS, EMGC-60-P-...<sup>2)</sup></b>	<b>1586276</b>	<b>EAMM-U-86-D60-60H-102</b>
<b>EMGA-60-P-...-SAS/SST<sup>2)</sup></b>	<b>1543240</b>	<b>EAMM-U-110-D60-60G-120</b>
<b>EMGA-60-P-...-EAS, EMGC-60-P-...<sup>2)</sup></b>	<b>1542264</b>	<b>EAMM-U-110-D60-60H-120</b>
<b>EMGA-80-P-...</b>	<b>1532949</b>	<b>EAMM-U-110-D60-80G-120</b>

- 1) The input torque must not exceed the max. perm. transferable torque of the parallel kit.  
 2) Gear unit drive shaft  $\varnothing$ : EMGA-60-P-...-SAS/SST: 11 mm; EMGA-60-P-...-EAS, EMGC-60-P: 14 mm

- - Note

Clamping component EADT for adjusting the toothed belt pretension with EAMM-U-110 → 28

### Features of the kits

- Space-saving gravity die-cast housing



Motor	Parallel kit	
Type	Part No.	Type
<b>EGSL-45</b>		
With servo motor		
<b>EMMS-AS-40-...</b>	<b>543150</b>	<b>EAMM-U-D32-40A</b>
<b>EGSL-55</b>		
With servo motor		
<b>EMMS-AS-55-...</b>	<b>543157</b>	<b>EAMM-U-D40-55A</b>
<b>EGSL-75</b>		
With servo motor		
<b>EMMS-AS-70-...</b>	<b>543165</b>	<b>EAMM-U-D60-70A</b>

# Parallel kits EAMM-U

Product range overview

## Permissible axis/motor combinations with spindle axis EGC-BS

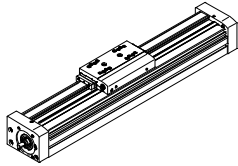

### Features of the kits

- Increased housing rigidity
- More flexible motor mounting possible
- Larger toothed belt bending radii for improved service life
- Use in combination with third-party motors on request

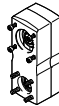

Motor/gear unit <sup>2)</sup>	Parallel kit	
Type	Part No.	Type
<b>EGC-70-...-BS</b>		
With servo motor		
EMME-AS-40-...	2155239	EAMM-U-50-S38-40P-78
EMMS-AS-40-...	1217708	EAMM-U-50-S38-40A-78
EMMS-AS-55-...	1218538	EAMM-U-60-S38-55A-91
With stepper motor		
EMMS-ST-42-...	1217945	EAMM-U-50-S38-42A-78
EMMS-ST-57-...	1218568	EAMM-U-60-S38-57A-91
With gear unit		
EMGA-40-P-...	2283732	EAMM-U-60-S38-40G-91
EMGC-40-P-...	2283732	EAMM-U-60-S38-40G-91
<b>EGC-80-...-BS</b>		
With servo motor		
EMMS-AS-55-...	1219370	EAMM-U-60-S48-55A-91 <sup>1)</sup>
EMME-AS-60-...	2629253	EAMM-U-70-S48-60P-96 <sup>1)</sup>
EMMS-AS-70-...	2787320	EAMM-U-70-S48-70A-96 <sup>1)</sup>
EMMS-AS-70-...	1217689	EAMM-U-86-S48-70A-102 <sup>1)</sup>
With stepper motor		
EMMS-ST-57-...	1219379	EAMM-U-60-S48-57A-91 <sup>1)</sup>
EMMS-ST-87-...	1217604	EAMM-U-86-S48-87A-177 <sup>1)</sup>
With gear unit		
EMGA-40-P-...	2283760	EAMM-U-60-S48-40G-91 <sup>1)</sup>
EMGC-40-P-...	2283760	EAMM-U-60-S48-40G-91 <sup>1)</sup>
EMGA-60-P-...-SAS/ SST <sup>3)</sup>	2801627	EAMM-U-70-S48-60G-96 <sup>1)</sup>
EMGA-60-P-...-EAS, EMGC-60-P-... <sup>3)</sup>	2801715	EAMM-U-70-S48-60H-96 <sup>1)</sup>
EMGA-60-P-...-SAS/ SST <sup>3)</sup>	1587251	EAMM-U-86-S48-60G-102 <sup>1)</sup>
EMGA-60-P-...-EAS, EMGC-60-P-... <sup>3)</sup>	1587338	EAMM-U-86-S48-60H-102 <sup>1)</sup>

Motor/gear unit <sup>2)</sup>	Parallel kit	
Type	Part No.	Type
<b>EGC-120-...-BS</b>		
With servo motor		
EMMS-AS-70-...	1217543	EAMM-U-86-S62-70A-177 <sup>1)</sup>
EMME-AS-80-...	2157004	EAMM-U-86-S62-80P-177 <sup>1)</sup>
EMME-AS-100-...	1217381	EAMM-U-110-S62-100A-207 <sup>1)</sup>
EMMS-AS-100-...	1217381	EAMM-U-110-S62-100A-207 <sup>1)</sup>
EMMS-AS-140-...	1219440	EAMM-U-145-S62-140A-288 <sup>1)</sup>
With stepper motor		
EMMS-ST-87-...	1217373	EAMM-U-86-S62-87A-177 <sup>1)</sup>
With gear unit		
EMGA-60-P-...-SAS/ SST <sup>3)</sup>	1587411	EAMM-U-86-S62-60G-177 <sup>1)</sup>
EMGA-60-P-...-EAS, EMGC-60-P-... <sup>3)</sup>	1587453	EAMM-U-86-S62-60H-177 <sup>1)</sup>
<b>EGC-185-...-BS</b>		
With servo motor		
EMME-AS-100-...	1220656	EAMM-U-110-S95-100A-207 <sup>1)</sup>
EMMS-AS-100-...	1220656	EAMM-U-110-S95-100A-207 <sup>1)</sup>
EMMS-AS-140-...	1220582	EAMM-U-145-S95-140A-288 <sup>1)</sup>
With gear unit		
EMGA-80-P-...	1589544	EAMM-U-110-S95-80G-207 <sup>1)</sup>

- 1) These parallel kits include a counter bearing EAMG for supporting the axis shaft.
- 2) The input torque must not exceed the max. perm. transferable torque of the parallel kit.
- 3) Gear unit drive shaft  $\varnothing$ : EMGA-60-P-...-SAS/-SST: 11 mm; EMGA-60-P-...-EAS, EMGC-60-P: 14 mm

Note

Clamping component EADT for adjusting the toothed belt pretension with EAMM-U-110 and EAMM-U-145 → 28

# Parallel kits EAMM-U

Product range overview

FESTO

## Permissible axis/motor combinations with spindle axis EGC-HD-BS

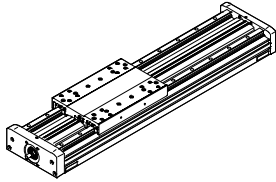

### Features of the kits

- Increased housing rigidity
- More flexible motor mounting possible
- Larger toothed belt bending radii for improved service life
- Use in combination with third-party motors on request

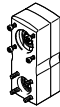

Motor/gear unit <sup>2)</sup>	Parallel kit	
Type	Part No.	Type
<b>EGC-HD-125</b>		
With servo motor		
EMME-AS-40-...	2155239	EAMM-U-50-S38-40P-78
EMMS-AS-40-...	1217708	EAMM-U-50-S38-40A-78
EMMS-AS-55-...	1218538	EAMM-U-60-S38-55A-91
With stepper motor		
EMMS-ST-42-...	1217945	EAMM-U-50-S38-42A-78
EMMS-ST-57-...	1218568	EAMM-U-60-S38-57A-91
With gear unit		
EMGA-40-P-...	2283732	EAMM-U-60-S38-40G-91
EMGC-40-P-...	2283732	EAMM-U-60-S38-40G-91
<b>EGC-HD-160</b>		
With servo motor		
EMMS-AS-55-...	1219370	EAMM-U-60-S48-55A-91 <sup>1)</sup>
EMME-AS-60-...	2629253	EAMM-U-70-S48-60P-96 <sup>1)</sup>
EMMS-AS-70-...	2787320	EAMM-U-70-S48-70A-96 <sup>1)</sup>
EMMS-AS-70-...	1217689	EAMM-U-86-S48-70A-102 <sup>1)</sup>
With stepper motor		
EMMS-ST-57-...	1219379	EAMM-U-60-S48-57A-91 <sup>1)</sup>
EMMS-ST-87-...	1217604	EAMM-U-86-S48-87A-177 <sup>1)</sup>
With gear unit		
EMGA-40-P-...	2283760	EAMM-U-60-S48-40G-91 <sup>1)</sup>
EMGC-40-P-...	2283760	EAMM-U-60-S48-40G-91 <sup>1)</sup>
EMGA-60-P-...-SAS/ SST <sup>3)</sup>	2801627	EAMM-U-70-S48-60G-96 <sup>1)</sup>
EMGA-60-P-...-EAS, EMGC-60-P-... <sup>3)</sup>	2801715	EAMM-U-70-S48-60H-96 <sup>1)</sup>
EMGA-60-P-...-SAS/ SST <sup>3)</sup>	1587251	EAMM-U-86-S48-60G-102 <sup>1)</sup>
EMGA-60-P-...-EAS, EMGC-60-P-... <sup>3)</sup>	1587338	EAMM-U-86-S48-60H-102 <sup>1)</sup>

Motor/gear unit <sup>2)</sup>	Parallel kit	
Type	Part No.	Type
<b>EGC-HD-220</b>		
With servo motor		
EMMS-AS-70-...	1217543	EAMM-U-86-S62-70A-177 <sup>1)</sup>
EMME-AS-80-...	2157004	EAMM-U-86-S62-80P-177 <sup>1)</sup>
EMME-AS-100-...	1217381	EAMM-U-110-S62-100A-207 <sup>1)</sup>
EMMS-AS-100-...	1217381	EAMM-U-110-S62-100A-207 <sup>1)</sup>
EMMS-AS-140-...	1219440	EAMM-U-145-S62-140A-288 <sup>1)</sup>
With stepper motor		
EMMS-ST-87-...	1217373	EAMM-U-86-S62-87A-177 <sup>1)</sup>
With gear unit		
EMGA-60-P-...-SAS/ SST <sup>3)</sup>	1587411	EAMM-U-86-S62-60G-177 <sup>1)</sup>
EMGA-60-P-...-EAS, EMGC-60-P-... <sup>3)</sup>	1587453	EAMM-U-86-S62-60H-177 <sup>1)</sup>

- 1) These parallel kits include a counter bearing EAMG for supporting the axis shaft.
- 2) The input torque must not exceed the max. perm. transferable torque of the parallel kit.
- 3) Gear unit drive shaft  $\varnothing$ : EMGA-60-P-...-SAS/-SST: 11 mm; EMGA-60-P-...-EAS, EMGC-60-P: 14 mm



Note

Clamping component EADT for adjusting the toothed belt pretension with EAMM-U-110 and EAMM-U-145 → 28



# Parallel kits EAMM-U

Product range overview

## Permissible axis/motor combinations with electric cylinder ESBF

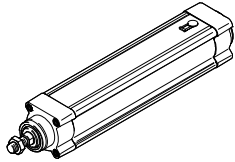

### Features of the kits

- Increased housing rigidity
- More flexible motor mounting possible
- Larger toothed belt bending radii for improved service life
- Use in combination with third-party motors on request



Motor/gear unit <sup>2)</sup>	Parallel kit	
Type	Part No.	Type
<b>ESBF-32</b>		
With servo motor		
EMME-AS-40-...	2153283	EAMM-U-50-D32-40P-78
	2154009	EAMM-U-50-D32-40P-78-S1 <sup>1)</sup>
EMMS-AS-40-...	1201591	EAMM-U-50-D32-40A-78
	1202302	EAMM-U-50-D32-40A-78-S1 <sup>1)</sup>
EMMS-AS-55-...	1210126	EAMM-U-60-D32-55A-91
	1210450	EAMM-U-60-D32-55A-91-S1 <sup>1)</sup>
EMME-AS-60-...	2619586	EAMM-U-70-D32-60P-96
	2619688	EAMM-U-70-D32-60P-96-S1 <sup>1)</sup>
With stepper motor		
EMMS-ST-42-...	1201607	EAMM-U-50-D32-42A-78
	1202312	EAMM-U-50-D32-42A-78-S1 <sup>1)</sup>
EMMS-ST-57-...	1210419	EAMM-U-60-D32-57A-91
	1210453	EAMM-U-60-D32-57A-91-S1 <sup>1)</sup>
With gear unit		
EMGA-40-P-...	1577358	EAMM-U-60-D32-40G-91
EMGC-40-P-...	1577346	EAMM-U-60-D32-40G-91-S1 <sup>1)</sup>
EMGA-60-P-...-EAS,	2778393	EAMM-U-70-D32-60H-96
EMGC-60-P-... <sup>3)</sup>	2781450	EAMM-U-70-D32-60H-96-S1 <sup>1)</sup>
EMGA-60-P-...-SAS/ SST <sup>3)</sup>	2748181	EAMM-U-70-D32-60G-96
	2778302	EAMM-U-70-D32-60G-96-S1 <sup>1)</sup>

Motor/gear unit <sup>2)</sup>	Parallel kit	
Type	Part No.	Type
<b>ESBF-40</b>		
With servo motor		
EMMS-AS-55-...	1210438	EAMM-U-60-D40-55A-91
	1210458	EAMM-U-60-D40-55A-91-S1 <sup>1)</sup>
EMME-AS-60-...	2617488	EAMM-U-70-D40-60P-96
	2546123	EAMM-U-70-D40-60P-96-S1 <sup>1)</sup>
EMMS-AS-70-...	2786204	EAMM-U-70-D40-70A-96
	2786316	EAMM-U-70-D40-70A-96-S1 <sup>1)</sup>
EMMS-AS-70-...	1212826	EAMM-U-86-D40-70A-102
	1212854	EAMM-U-86-D40-70A-102-S1 <sup>1)</sup>
EMME-AS-80-...	2802441	EAMM-U-86-D40-80P-102
	2802656	EAMM-U-86-D40-80P-102-S1 <sup>1)</sup>
With stepper motor		
EMMS-ST-57-...	1210442	EAMM-U-60-D40-57A-91
	1210462	EAMM-U-60-D40-57A-91-S1 <sup>1)</sup>
EMMS-ST-87-...	1215802	EAMM-U-86-D40-87A-102
	1215814	EAMM-U-86-D40-87A-102-S1 <sup>1)</sup>
With gear unit		
EMGA-40-P-...	1577165	EAMM-U-60-D40-40G-91
EMGC-40-P-...	1435968	EAMM-U-60-D40-40G-91-S1 <sup>1)</sup>
EMGA-60-P-...-EAS,	2786101	EAMM-U-70-D40-60H-96
EMGC-60-P-... <sup>3)</sup>	2786137	EAMM-U-70-D40-60H-96-S1 <sup>1)</sup>
EMGA-60-P-...-SAS/ SST <sup>3)</sup>	2785471	EAMM-U-70-D40-60G-96
	2785542	EAMM-U-70-D40-60G-96-S1 <sup>1)</sup>
EMGA-60-P-...-EAS,	1586496	EAMM-U-86-D40-60H-102
EMGC-60-P-... <sup>3)</sup>	1586372	EAMM-U-86-D40-60H-102-S1 <sup>1)</sup>
EMGA-60-P-...-SAS/ SST <sup>3)</sup>	1586445	EAMM-U-86-D40-60G-102
	1586429	EAMM-U-86-D40-60G-102-S1 <sup>1)</sup>

1) With degree of protection IP65

2) The input torque must not exceed the max. perm. transferable torque of the parallel kit.

3) Gear unit drive shaft  $\varnothing$ : EMGA-60-P-...-SAS/-SST: 11 mm; EMGA-60-P-...-EAS, EMGC-60-P: 14 mm

# Parallel kits EAMM-U

Product range overview



## Permissible axis/motor combinations with electric cylinder ESBF

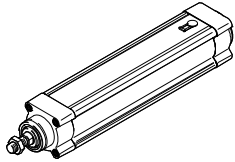

### Features of the kits

- Increased housing rigidity
- More flexible motor mounting possible
- Larger toothed belt bending radii for improved service life
- Use in combination with third-party motors on request

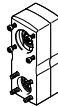

Motor/gear unit <sup>2)</sup>	Parallel kit	
Type	Part No.	Type
<b>ESBF-50</b>		
With servo motor		
EMME-AS-70-...	2786899	EAMM-U-70-D50-70A-96
	2756078	EAMM-U-70-D50-70A-96-S1 <sup>1)</sup>
EMME-AS-80-...	2803053	EAMM-U-86-D50-80P-102
	2803073	EAMM-U-86-D50-80P-102-S1 <sup>1)</sup>
EMME-AS-100-...	2799424	EAMM-U-110-D50-100A-120
	2799488	EAMM-U-110-D50-100A-120-S1 <sup>1)</sup>
EMMS-AS-100-...	2799424	EAMM-U-110-D50-100A-120
	2799488	EAMM-U-110-D50-100A-120-S1 <sup>1)</sup>
With stepper motor		
EMMS-ST-87-...	2802708	EAMM-U-86-D50-87A-102
	2802742	EAMM-U-86-D50-87A-102-S1 <sup>1)</sup>
With gear unit		
EMGA-60-P-...-EAS, EMGC-60-P-... <sup>3)</sup>	2803326	EAMM-U-86-D50-60H-102
	2803325	EAMM-U-86-D50-60H-102-S1 <sup>1)</sup>
EMGA-60-P-...-SAS/ SST <sup>3)</sup>	2803125	EAMM-U-86-D50-60G-102
	2803197	EAMM-U-86-D50-60G-102-S1 <sup>1)</sup>
EMGA-60-P-...-EAS, EMGC-60-P-... <sup>3)</sup>	2798760	EAMM-U-110-D50-60H-120
	2799150	EAMM-U-110-D50-60H-120-S1 <sup>1)</sup>
EMGA-60-P-...-SAS/ SST <sup>3)</sup>	2797368	EAMM-U-110-D50-60G-120
	2798665	EAMM-U-110-D50-60G-120-S1 <sup>1)</sup>
EMGA-80-P-...	2799196	EAMM-U-110-D50-80G-120
	2799281	EAMM-U-110-D50-80G-120-S1 <sup>1)</sup>
<b>ESBF-63</b>		
With servo motor		
EMMS-AS-70-...	1212477	EAMM-U-86-D60-70A-102
	1212835	EAMM-U-86-D60-70A-102-S1 <sup>1)</sup>
EMME-AS-80-...	2155875	EAMM-U-86-D60-80P-102
	2156527	EAMM-U-86-D60-80P-102-S1 <sup>1)</sup>
EMME-AS-100-...	1202436	EAMM-U-110-D60-100A-120
	1203112	EAMM-U-110-D60-100A-120-S1 <sup>1)</sup>
EMMS-AS-100-...	1202436	EAMM-U-110-D60-100A-120
	1203112	EAMM-U-110-D60-100A-120-S1 <sup>1)</sup>
With stepper motor		
EMMS-ST-87-...	1215784	EAMM-U-86-D60-87A-102

Motor/gear unit <sup>2)</sup>	Parallel kit	
Type	Part No.	Type
<b>ESBF-63</b>		
With gear unit		
EMGA-60-P-...-SAS/ SST <sup>3)</sup>	1586347	EAMM-U-86-D60-60G-102
	1437163	EAMM-U-86-D60-60G-102-S1 <sup>1)</sup>
EMGA-60-P-...-EAS, EMGC-60-P-... <sup>3)</sup>	1586276	EAMM-U-86-D60-60H-102
	1530837	EAMM-U-86-D60-60H-102-S1 <sup>1)</sup>
EMGA-60-P-...-SAS/ SST <sup>3)</sup>	1543240	EAMM-U-110-D60-60G-120
	1436183	EAMM-U-110-D60-60G-120-S1 <sup>1)</sup>
EMGA-60-P-...-EAS, EMGC-60-P-... <sup>3)</sup>	1542264	EAMM-U-110-D60-60H-120
	1530621	EAMM-U-110-D60-60H-120-S1 <sup>1)</sup>
EMGA-80-P-...	1532949	EAMM-U-110-D60-80G-120
	1530875	EAMM-U-110-D60-80G-120-S1 <sup>1)</sup>
<b>ESBF-80</b>		
With servo motor		
EMME-AS-100-...	1465438	EAMM-U-110-D80-100A-120
	1433650	EAMM-U-110-D80-100A-120-S1 <sup>1)</sup>
EMMS-AS-100-...	1465438	EAMM-U-110-D80-100A-120
	1433650	EAMM-U-110-D80-100A-120-S1 <sup>1)</sup>
EMMS-AS-140-...	1465530	EAMM-U-145-D80-140A-188
	1433709	EAMM-U-145-D80-140A-188-S1 <sup>1)</sup>
With gear unit		
EMGA-80-P-...	1589614	EAMM-U-110-D80-80G-120
	1589706	EAMM-U-110-D80-80G-120-S1 <sup>1)</sup>
<b>ESBF-100</b>		
With servo motor		
EMMS-AS-140-...	1465541	EAMM-U-145-D100-140A-188
	1433852	EAMM-U-145-D100-140A-188-S1 <sup>1)</sup>
With gear unit		
EMGA-120-P-...	2803620	EAMM-U-145-D100-120G-188
	2803622	EAMM-U-145-D100-120G-188-S1 <sup>1)</sup>

1) With degree of protection IP65

2) The input torque must not exceed the max. perm. transferable torque of the parallel kit.

3) Gear unit drive shaft  $\varnothing$ : EMGA-60-P-...-SAS/-SST: 11 mm; EMGA-60-P-...-EAS, EMGC-60-P: 14 mm



Note

Clamping component EADT for adjusting the toothed belt pretension with EAMM-U-110 and EAMM-U-145 → 28

# Parallel kits EAMM-U

Product range overview

## Permissible axis/motor combinations with spindle axis DGE-SP

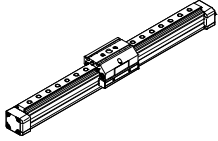

### Features of the kits

- Space-saving gravity die-cast housing



Motor	Parallel kit	
Type	Part No.	Type
<b>DGE-25</b>		
With servo motor		
<b>EMMS-AS-55-...</b>	<b>543230</b>	<b>EAMM-U-E32-55A</b>
With motor unit		
<b>MTR-DCI-42S-...-G07</b>	<b>543228</b>	<b>EAMM-U-E32-42B</b>
<b>MTR-DCI-42S-...-G14</b>	<b>543229</b>	<b>EAMM-U-E32-42C</b>
<b>DGE-40</b>		
With servo motor		
<b>EMMS-AS-70-...</b>	<b>543234</b>	<b>EAMM-U-E48-70A</b>
With motor unit		
<b>MTR-DCI-52S-...-G7</b>	<b>543232</b>	<b>EAMM-U-E48-52B</b>
<b>MTR-DCI-52S-...-G14</b>	<b>543233</b>	<b>EAMM-U-E48-52C</b>

# Parallel kits EAMM-U

Product range overview

## Permissible axis/motor combinations with positioning axis DMES

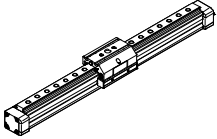

### Features of the kits

- Space-saving gravity die-cast housing



Motor	Parallel kit	
Type	Part No.	Type
<b>DMES-18</b>		
With servo motor		
<b>EMMS-AS-40-...</b>	<b>543226</b>	<b>EAMM-U-E24-40A</b>
With motor unit		
<b>MTR-DCI-32S-...</b>	<b>543225</b>	<b>EAMM-U-E24-32B</b>
<b>DMES-25</b>		
With servo motor		
<b>EMMS-AS-55-...</b>	<b>543230</b>	<b>EAMM-U-E32-55A</b>
With motor unit		
<b>MTR-DCI-42S-...-G7</b>	<b>543228</b>	<b>EAMM-U-E32-42B</b>
<b>MTR-DCI-42S-...-G14</b>	<b>543229</b>	<b>EAMM-U-E32-42C</b>
<b>DMES-40</b>		
With servo motor		
<b>EMMS-AS-70-...</b>	<b>543234</b>	<b>EAMM-U-E48-70A</b>
With motor unit		
<b>MTR-DCI-52S-...-G7</b>	<b>543232</b>	<b>EAMM-U-E48-52B</b>
<b>MTR-DCI-52S-...-G14</b>	<b>543233</b>	<b>EAMM-U-E48-52C</b>

-  Note

At ambient temperatures below room temperature, the frictional torques increase in the case of the DMES-...-GF (plain-bearing guide).

# Parallel kits EAMM-U

Type code

## Features of the kits



- Increased housing rigidity
- More flexible motor mounting possible
- Larger toothed belt bending radii for improved service life
- Optionally with degree of protection IP65
- Use in combination with third-party motors on request

EAMM – U – 50 – D32 – 40A – 78 –

### Type

EAMM	Kit
------	-----

### Motor configuration

U	Parallel
---	----------

### Size

### Axis mechanism interface

D32	DNCE-32, EGSL-45, ESBF-32
D40	DNCE-40, EGSL-55, ESBF-40
D50	ESBF-50
D60	DNCE-63, EGSL-63, ESBF-63
D80	ESBF-80
D100	ESBF-100
S38	EGC-70-...-BS, EGC-HD-125-...-BS
S48	EGC-80-...-BS, EGC-HD-160-...-BS
S62	EGC-120-...-BS, EGC-HD-220-...-BS
S95	EGC-185-...-BS

### Motor interface

40P	Servo motor EMME-AS-40
60P	Servo motor EMME-AS-60
80P	Servo motor EMME-AS-80
40A	Servo motor EMMS-AS-40
55A	Servo motor EMMS-AS-55
70A	Servo motor EMMS-AS-70
100A	Servo motor EMME-AS-100, EMMS-AS-100
140A	Servo motor EMMS-AS-140
42A	Stepper motor EMMS-ST-42
57A	Stepper motor EMMS-ST-57
87A	Stepper motor EMMS-ST-87
32B	Motor unit MTR-DCI-32S
42B/C	Motor unit MTR-DCI-42S
52B/C	Motor unit MTR-DCI-52S
62B/C	Motor unit MTR-DCI-62S
40G	Gear unit EMGA-40
60G	Gear unit EMGA-60-P-...-SAS/SST
60H	Gear unit EMGA-60-P-...-EAS, EMGC-60-P
80G	Gear unit EMGA-80
120G	Gear unit EMGA-120

### Centre distance

### Special design

S1	Degree of protection IP65
----	---------------------------

# Parallel kits EAMM-U

Type code

Features of the kits



- Space-saving gravity die-cast housing

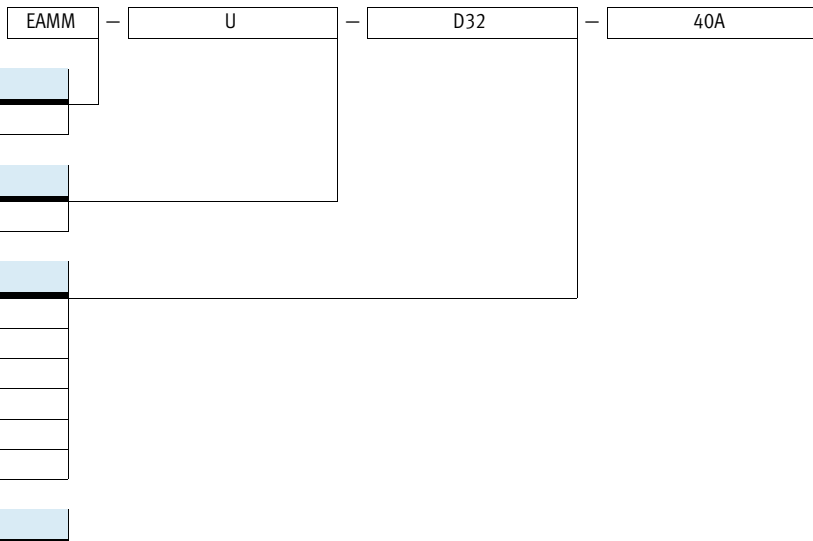

Type	
EAMM	Kit

Motor configuration	
U	Parallel

Axis mechanism interface	
D32	DNCE-32, EGSL-45
D40	DNCE-40, EGSL-55
D60	DNCE-63, EGSL-75
E24	DMES-18
E32	DGE-25-SP, DMES-25
E48	DGE-40-SP, DMES-40

Motor interface	
40A	Servo motor EMMS-AS-40
55A	Servo motor EMMS-AS-55
70A	Servo motor EMMS-AS-70
32B	Motor unit MTR-DCI-32S
42B	Motor unit MTR-DCI-42S-...-G7
42C	Motor unit MTR-DCI-42S-...-G14
52B	Motor unit MTR-DCI-52S-...-G7
52C	Motor unit MTR-DCI-52S-...-G14

# Parallel kits EAMM-U

Technical data

**Features:**

- Increased housing rigidity
- More flexible motor mounting possible
- Larger toothed belt bending radii for improved service life
- Optionally with degree of protection IP65
- Use in combination with third-party motors on request

**Materials:**

Housing: Wrought aluminium alloy  
 Clamping sleeve, toothed belt pulley: Corrosion-resistant steel  
 Toothed belt: Polychloroprene  
 Screws: Galvanised steel

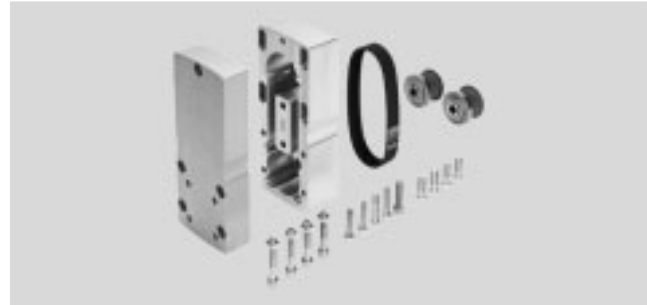

General technical data									
Type	For axis	Transferable torque [Nm]	Mass moment of inertia [kgmm <sup>2</sup> ]	Max. rotational speed [rpm]	No-load driving torque [Nm]	Weight [g]	Protection class <sup>1)</sup>	→ Page	
EAMM-U-50-D32-32B-78	DNCE, EGSL	1	12.1	6000	0.01	608	IP40	19	
EAMM-U-50-D32-40A-78	DNCE, EGSL, ESBF					600	IP40		
EAMM-U-50-D32-40A-78-S1	DNCE, ESBF					620	IP65		
EAMM-U-50-D32-40P-78	DNCE, EGSL, ESBF					596	IP40		
EAMM-U-50-D32-40P-78-S1	DNCE, ESBF					610	IP65		
EAMM-U-50-D32-42A-78	DNCE, EGSL					610	IP40		
EAMM-U-50-D32-42A-78-S1	DNCE					630	IP65		
EAMM-U-50-S38-40A-78	EGC-BS,					580	IP40		23
EAMM-U-50-S38-40P-78	EGC-HD-BS					577	IP40		
EAMM-U-50-S38-42A-78						590	IP40		
EAMM-U-60-D32-40G-91	DNCE, EGSL, ESBF	3	26.7	6000	0.07	1100	IP40	19	
EAMM-U-60-D32-40G-91-S1	DNCE, ESBF					1140	IP65		
EAMM-U-60-D32-42B/C-91	DNCE, EGSL					1100	IP40		
EAMM-U-60-D32-42B/C-91-S1	DNCE					1140	IP65		
EAMM-U-60-D32-55A-91	DNCE, EGSL, ESBF					1050	IP40		
EAMM-U-60-D32-55A-91-S1	DNCE, ESBF					1100	IP65		
EAMM-U-60-D32-57A-91	DNCE, EGSL, ESBF					1160	IP40		
EAMM-U-60-D32-57A-91-S1	DNCE, ESBF					1190	IP65		
EAMM-U-60-D40-40G-91	DNCE, EGSL, ESBF					1080	IP40		
EAMM-U-60-D40-40G-91-S1	DNCE, ESBF					1130	IP65		
EAMM-U-60-D40-42B/C-91	DNCE, EGSL					1080	IP40		
EAMM-U-60-D40-42B/C-91-S1	DNCE					1130	IP65		
EAMM-U-60-D40-55A-91	DNCE, EGSL, ESBF					1040	IP40		
EAMM-U-60-D40-55A-91-S1	DNCE, ESBF					1080	IP65		
EAMM-U-60-D40-57A-91	DNCE, EGSL, ESBF					1140	IP40		
EAMM-U-60-D40-57A-91-S1	DNCE, ESBF					1170	IP65		
EAMM-U-60-S38-40G-91	EGC-BS,					1040	IP40		23
EAMM-U-60-S38-55A-91	EGC-HD-BS					990	IP40		
EAMM-U-60-S38-57A-91						1090	IP40		
EAMM-U-60-S48-40G-91						1110	IP40		
EAMM-U-60-S48-55A-91		1060	IP40						
EAMM-U-60-S48-57A-91		1160	IP40						
EAMM-U-70-D32-52B/C-96	DNCE, EGSL	7	118	5000	0.18	1800	IP40	19	
EAMM-U-70-D32-52B/C-96-S1	DNCE					1820	IP65		
EAMM-U-70-D32-60G-96	DNCE, EGSL, ESBF					1760	IP40		
EAMM-U-70-D32-60G-96-S1	DNCE, ESBF					1790	IP65		
EAMM-U-70-D32-60H-96	DNCE, EGSL, ESBF					1750	IP40		
EAMM-U-70-D32-60H-96-S1	DNCE, ESBF					1780	IP65		
EAMM-U-70-D32-60P-96	DNCE, EGSL, ESBF					1750	IP40		
EAMM-U-70-D32-60P-96-S1	DNCE, ESBF					1770	IP65		

1) Only in combination with attached motor and axis.

# Parallel kits EAMM-U

Technical data



General technical data													
Type	For axis	Transferable torque [Nm]	Mass moment of inertia [kgmm <sup>2</sup> ]	Max. rotational speed [rpm]	No-load driving torque [Nm]	Weight [g]	Protection class <sup>1)</sup>	→ Page					
EAMM-U-70-D32-70A-96	DNCE, EGSL	7	118	5000	0.18	1720	IP40	19					
EAMM-U-70-D32-70A-96-S1	DNCE					1750	IP65						
EAMM-U-70-D40-52B/C-96	DNCE, EGSL					1780	IP40						
EAMM-U-70-D40-52B/C-96-S1	DNCE					1800	IP65						
EAMM-U-70-D40-60G-96	DNCE, EGSL, ESBF					1740	IP40						
EAMM-U-70-D40-60G-96-S1	DNCE, ESBF					1770	IP65						
EAMM-U-70-D40-60H-96	DNCE, EGSL, ESBF					1730	IP40						
EAMM-U-70-D40-60H-96-S1	DNCE, ESBF					1760	IP65						
EAMM-U-70-D40-60P-96	DNCE, EGSL, ESBF					1730	IP40						
EAMM-U-70-D40-60P-96-S1	DNCE, ESBF					1750	IP65						
EAMM-U-70-D40-70A-96	DNCE, EGSL, ESBF					1700	IP40						
EAMM-U-70-D40-70A-96-S1	DNCE, ESBF					1730	IP65						
EAMM-U-70-S48-60G-96	EGC-BS, EGC-HD-BS					1780	IP40						
EAMM-U-70-S48-60H-96						1780	IP40						
EAMM-U-70-S48-60P-96						1790	IP40						
EAMM-U-70-S48-70A-96		1750	IP40										
EAMM-U-86-D40-52B/C-102	DNCE, EGSL	9.5	175	5000	0.25	2520	IP40	20					
EAMM-U-86-D40-52B/C-102-S1	DNCE					2540	IP65						
EAMM-U-86-D40-60G-102	DNCE, EGSL, ESBF					2480	IP40						
EAMM-U-86-D40-60G-102-S1	DNCE, ESBF					2500	IP65						
EAMM-U-86-D40-60H-102	DNCE, EGSL, ESBF					2470	IP40						
EAMM-U-86-D40-60H-102-S1	DNCE, ESBF					2490	IP65						
EAMM-U-86-D40-70A-102	DNCE, EGSL, ESBF					2450	IP40						
EAMM-U-86-D40-70A-102-S1	DNCE, ESBF					2460	IP65						
EAMM-U-86-D40-80P-102	DNCE, EGSL, ESBF					2300	IP40						
EAMM-U-86-D40-80P-102-S1	DNCE, ESBF					2320	IP65						
EAMM-U-86-D40-87A-102	DNCE, EGSL, ESBF					2510	IP40						
EAMM-U-86-D40-87A-102-S1	DNCE, ESBF					2530	IP65						
EAMM-U-86-D50-80P-102	ESBF	9.5	175	5000	0.25	2330	IP40	24					
EAMM-U-86-D50-80P-102-S1						2350	IP65						
EAMM-U-86-D50-87A-102						2550	IP40						
EAMM-U-86-D50-87A-102-S1						2560	IP65						
EAMM-U-86-D50-60H-102						2500	IP40						
EAMM-U-86-D50-60H-102-S1						2520	IP65						
EAMM-U-86-D50-60G-102						2510	IP40						
EAMM-U-86-D50-60G-102-S1						2530	IP65						
EAMM-U-86-D60-52B/C-102	DNCE, EGSL, ESBF	9.5	175	5000	0.25	2520	IP40	20					
EAMM-U-86-D60-52B/C-102-S1	DNCE, ESBF					2540	IP65						
EAMM-U-86-D60-60G-102	DNCE, EGSL, ESBF					2480	IP40						
EAMM-U-86-D60-60G-102-S1	DNCE, ESBF					2500	IP65						
EAMM-U-86-D60-60H-102	DNCE, EGSL, ESBF					2470	IP40						
EAMM-U-86-D60-60H-102-S1	DNCE, ESBF					2490	IP65						
EAMM-U-86-D60-70A-102	DNCE, EGSL, ESBF					2440	IP40						
EAMM-U-86-D60-70A-102-S1	DNCE, ESBF					2460	IP65						
EAMM-U-86-D60-80P-102	DNCE, EGSL, ESBF					2300	IP40						
EAMM-U-86-D60-80P-102-S1	DNCE, ESBF					2320	IP65						
EAMM-U-86-D60-87A-102	DNCE, EGSL, ESBF					2510	IP40						
EAMM-U-86-D60-87A-102-S1	DNCE, ESBF					2520	IP65						
EAMM-U-86-S48-60G-102	EGC-BS, EGC-HD-BS					9.5	175		5000	0.25	2480	IP40	23
EAMM-U-86-S48-60H-102											2470	IP40	
EAMM-U-86-S48-70A-102		2440	IP40										
EAMM-U-86-S48-87A-177		3270	IP40										

1) Only in combination with attached motor and axis



# Parallel kits EAMM-U

Technical data



General technical data														
Type	For axis	Transferable torque [Nm]	Mass moment of inertia [kgmm <sup>2</sup> ]	Max. rotational speed [rpm]	No-load driving torque [Nm]	Weight [g]	Protection class <sup>1)</sup>	→ Page						
EAMM-U-86-S62-60G-177	EGC-BS, EGC-HD-BS	9.5	175	5000	0.25	3300	IP40	23						
EAMM-U-86-S62-60H-177						3290	IP40							
EAMM-U-86-S62-70A-177						3270	IP40							
EAMM-U-86-S62-80P-177						3130	IP40							
EAMM-U-86-S62-87A-177						3330	IP40							
EAMM-U-110-D50-100A-120	ESBF	25	799	5000	0.3	4990	IP40	24						
EAMM-U-110-D50-100A-120-S1						5050	IP65							
EAMM-U-110-D50-60H-120						5280	IP40							
EAMM-U-110-D50-60H-120-S1						5310	IP65							
EAMM-U-110-D50-60G-120						5290	IP40							
EAMM-U-110-D50-60G-120-S1						5320	IP65							
EAMM-U-110-D50-80G-120						5160	IP40							
EAMM-U-110-D50-80G-120-S1						5220	IP65							
EAMM-U-110-D60-60G-120	DNCE, EGSL, ESBF	25	799	5000	0.3	5250	IP40	19, 24						
EAMM-U-110-D60-60G-120-S1						5080	IP65							
EAMM-U-110-D60-60H-120						5240	IP40							
EAMM-U-110-D60-60H-120-S1						5270	IP65							
EAMM-U-110-D60-62B-120						5230	IP40							
EAMM-U-110-D60-62B-120-S1						5270	IP65							
EAMM-U-110-D60-80G-120						5120	IP40							
EAMM-U-110-D60-80G-120-S1						5180	IP65							
EAMM-U-110-D60-100A-120						4950	IP40							
EAMM-U-110-D60-100A-120-S1						5020	IP65							
EAMM-U-110-D80-80G-120						ESBF						5240	IP40	24
EAMM-U-110-D80-80G-120-S1												5310	IP65	
EAMM-U-110-D80-100A-120												5070	IP40	
EAMM-U-110-D80-100A-120-S1												5140	IP65	
EAMM-U-110-S62-100A-207	EGC-BS, EGC-HD-BS	25	799	5000	0.3	6900	IP40	23						
EAMM-U-110-S95-100A-207						6810	IP40							
EAMM-U-110-S95-80G-207						6940	IP40							
EAMM-U-145-D80-140A-188	ESBF	50	2270	4000	2.0	11900	IP40	24						
EAMM-U-145-D80-140A-188-S1						12100	IP65							
EAMM-U-145-D100-120G-188						12000	IP40							
EAMM-U-145-D100-120G-188-S1						12100	IP65							
EAMM-U-145-D100-140A-188						11800	IP40							
EAMM-U-145-D100-140A-188-S1						11900	IP65							
EAMM-U-145-S62-140A-288						EGC-BS, EGC-HD-BS						15030	IP40	23
EAMM-U-145-S95-140A-288	EGC-BS	14850	IP40											

1) Only in combination with attached motor and axis

Operating and environmental conditions		
Ambient temperature	[°C]	-10 ... +60
Storage temperature	[°C]	-25 ... +60
Relative air humidity	[%]	0 ... 95
Corrosion resistance class CRC <sup>2)</sup>		2
Note on materials		RoHS-compliant

2) Corrosion resistance class CRC 2 to Festo standard FN 940070  
Moderate corrosion stress. Indoor applications in which condensation may occur. External visible parts with primarily decorative requirements for the surface and which are in direct contact with the ambient atmosphere typical for industrial applications.

# Parallel kits EAMM-U

Technical data

Features:

- Space-saving gravity die-cast housing

Materials:

Housing: Gravity die-cast aluminium  
 Clamping component, clamping sleeve, toothed belt pulley: Corrosion-resistant steel  
 Toothed belt: Polychloroprene  
 Screws: Galvanised steel



General technical data								
Type	For axis	Transferable torque [Nm]	Mass moment of inertia [kgmm <sup>2</sup> ]	Max. rotational speed [rpm]	No-load driving torque [Nm]	Weight [g]	Protection class <sup>1)</sup>	→ Page
EAMM-U-D32-32B	DNCE	1	2.93	6000	0.05	300	IP40	22
EAMM-U-D32-40A	DNCE, EGSL	1	2.93	6000	0.05	300	IP40	
EAMM-U-D40-42B	DNCE	3	10.0	5000	0.1	660	IP40	
EAMM-U-D40-42C	DNCE	3	10.0	5000	0.1	690	IP40	
EAMM-U-D40-55A	DNCE, EGSL	3	10.0	5000	0.1	530	IP40	
EAMM-U-D60-52B	DNCE	5.5	70.5	4000	0.3	1530	IP40	
EAMM-U-D60-52C	DNCE	5.5	70.5	4000	0.3	1630	IP40	
EAMM-U-D60-70A	DNCE, EGSL	5.5	70.5	4000	0.3	1170	IP40	
EAMM-U-E24-32B	DMES	1	3.02	3000	0.05	240	IP40	27
EAMM-U-E24-40A	DMES	1	3.02	3000	0.05	240	IP40	
EAMM-U-E32-42B	DGE-SP, DMES	3	10.2	3000	0.1	660	IP40	
EAMM-U-E32-42C	DGE-SP, DMES	3	10.2	3000	0.1	690	IP40	
EAMM-U-E32-55A	DGE-SP, DMES	3	10.2	3000	0.1	540	IP40	
EAMM-U-E48-52B	DGE-SP, DMES	5.5	71.1	3000	0.3	1700	IP40	
EAMM-U-E48-52C	DGE-SP, DMES	5.5	71.1	3000	0.3	1800	IP40	
EAMM-U-E48-70A	DGE-SP, DMES	5.5	71.1	3000	0.3	1300	IP40	

1) Only in combination with attached motor and axis.

Operating and environmental conditions		
Ambient temperature	[°C]	0 ... +50
Storage temperature	[°C]	-25 ... +60
Relative air humidity	[%]	0 ... 95
Corrosion resistance class CRC <sup>2)</sup>		1
Note on materials	Contains PWIS (paint-wetting impairment substances)	
	RoHS-compliant	

2) Corrosion resistance class CRC 1 to Festo standard FN 940070  
 Low corrosion stress. For dry indoor applications or transport and storage protection. Also applies to parts behind covers, in the non-visible interior area, and parts which are covered in the application (e.g. drive trunnions).

# Parallel kits EAMM-U

Technical data



## Dimensions and ordering data

Download CAD data → [www.festo.com](http://www.festo.com)

EGSL-...

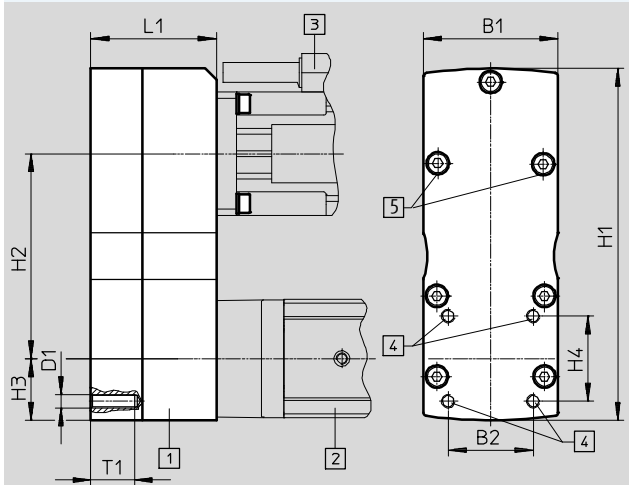

Illustration:

- 1 Parallel kit
- 2 Mini slide
- 3 Motor
- 4 Interface for mounting accessories
- 5 Only for EAMM-U-...-S1 (with degree of protection IP65)

DNCE-...

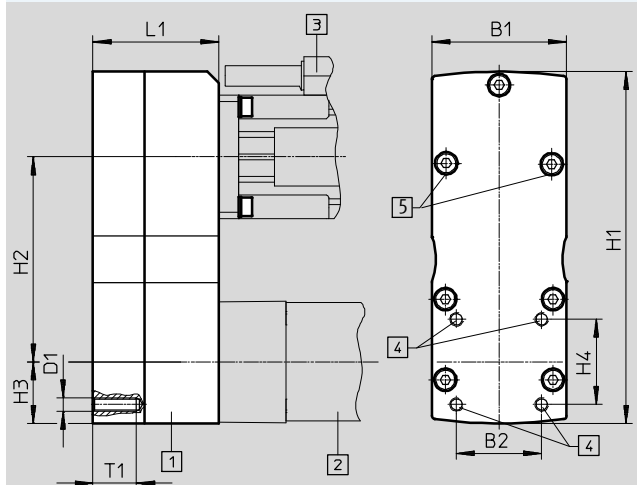

Illustration:

- 1 Parallel kit
- 2 Electric cylinder
- 3 Motor
- 4 Interface for mounting accessories
- 5 Only for EAMM-U-...-S1 (with degree of protection IP65)

Type	B1	B2	D1	H1	H2 ±1	H3	H4	L1	T1 +0.2	Part No.	Type									
EAMM-U-50-D32-32B-78	50	32.5	M6	128.8	78	22.8	32.5	45	15	1570862	EAMM-U-50-D32-32B-78									
EAMM-U-50-D32-40A-78										1201591	EAMM-U-50-D32-40A-78									
EAMM-U-50-D32-40A-78-S1										1202302	EAMM-U-50-D32-40A-78-S1									
EAMM-U-50-D32-40P-78										2153283	EAMM-U-50-D32-40P-78									
EAMM-U-50-D32-40P-78-S1										2154009	EAMM-U-50-D32-40P-78-S1									
EAMM-U-50-D32-42A-78										1201607	EAMM-U-50-D32-42A-78									
EAMM-U-50-D32-42A-78-S1										1202312	EAMM-U-50-D32-42A-78-S1									
EAMM-U-60-D32-40G-91	60	32.5	M6	157	91.5	27.5	32.5	56	15	1577358	EAMM-U-60-D32-40G-91									
EAMM-U-60-D32-40G-91-S1										1577346	EAMM-U-60-D32-40G-91-S1									
EAMM-U-60-D32-42B/C-91										1577393	EAMM-U-60-D32-42B/C-91									
EAMM-U-60-D32-42B/C-91-S1										1577380	EAMM-U-60-D32-42B/C-91-S1									
EAMM-U-60-D32-55A-91										1210126	EAMM-U-60-D32-55A-91									
EAMM-U-60-D32-55A-91-S1										1210450	EAMM-U-60-D32-55A-91-S1									
EAMM-U-60-D32-57A-91										1210419	EAMM-U-60-D32-57A-91									
EAMM-U-60-D32-57A-91-S1										1210453	EAMM-U-60-D32-57A-91-S1									
EAMM-U-60-D40-40G-91										38	M6	157	91.5	27.5	32.5	56	15	1577165	EAMM-U-60-D40-40G-91	
EAMM-U-60-D40-40G-91-S1		1435968	EAMM-U-60-D40-40G-91-S1																	
EAMM-U-60-D40-42B/C-91		1570950	EAMM-U-60-D40-42B/C-91																	
EAMM-U-60-D40-42B/C-91-S1		1430735	EAMM-U-60-D40-42B/C-91-S1																	
EAMM-U-60-D40-55A-91		1210438	EAMM-U-60-D40-55A-91																	
EAMM-U-60-D40-55A-91-S1		1210458	EAMM-U-60-D40-55A-91-S1																	
EAMM-U-60-D40-57A-91		1210442	EAMM-U-60-D40-57A-91																	
EAMM-U-60-D40-57A-91-S1		1210462	EAMM-U-60-D40-57A-91-S1																	
EAMM-U-70-D32-52B/C-96		70	32.5	M6	173.5	96	34.5	32.5	64.5									15	2755890	EAMM-U-70-D32-52B/C-96
EAMM-U-70-D32-52B/C-96-S1																			2781778	EAMM-U-70-D32-52B/C-96-S1
EAMM-U-70-D32-60G-96										2748181	EAMM-U-70-D32-60G-96									
EAMM-U-70-D32-60G-96-S1	2778302									EAMM-U-70-D32-60G-96-S1										
EAMM-U-70-D32-60H-96	2778393									EAMM-U-70-D32-60H-96										
EAMM-U-70-D32-60H-96-S1	2781450									EAMM-U-70-D32-60H-96-S1										
EAMM-U-70-D32-60P-96	2619586									EAMM-U-70-D32-60P-96										
EAMM-U-70-D32-60P-96-S1	2619688									EAMM-U-70-D32-60P-96-S1										

# Parallel kits EAMM-U

Technical data

FESTO

## Dimensions and ordering data

Download CAD data → [www.festo.com](http://www.festo.com)

EGSL-...

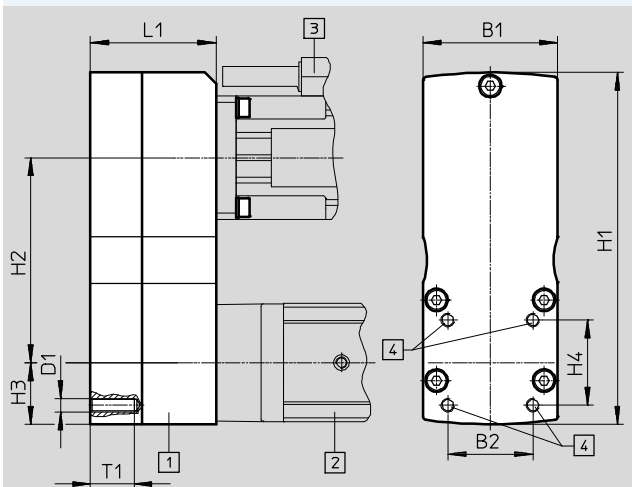

Illustration:

- 1 Parallel kit
- 2 Mini slide
- 3 Motor
- 4 Interface for mounting accessories

DNCE-...

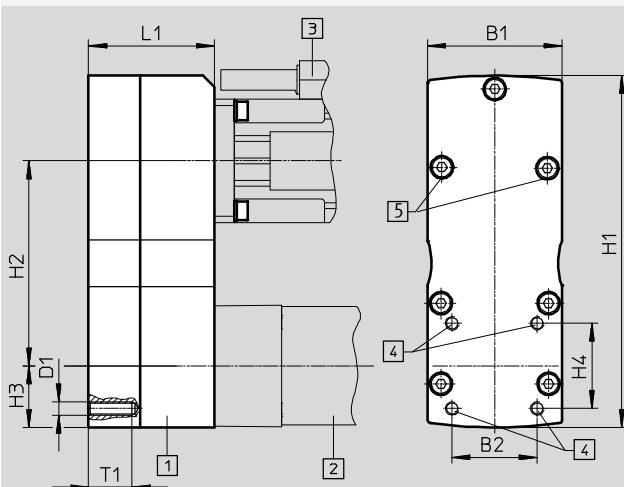

Illustration:

- 1 Parallel kit
- 2 Electric cylinder
- 3 Motor
- 4 Interface for mounting accessories
- 5 Only for EAMM-U-...-S1 (with degree of protection IP65)

Type	B1	B2	D1	H1	H2 ±1	H3	H4	L1	T1 +0.2	Part No.	Type									
EAMM-U-70-D32-70A-96	70	32.5	M6	173.5	96	34.5	32.5	64.5	15	275565	EAMM-U-70-D32-70A-96									
EAMM-U-70-D32-70A-96-S1										2781711	EAMM-U-70-D32-70A-96-S1									
EAMM-U-70-D40-52B/C-96	70	38	M6	173.5	96	34.5	38	64.5	15	2786802	EAMM-U-70-D40-52B/C-96									
EAMM-U-70-D40-52B/C-96-S1										2786845	EAMM-U-70-D40-52B/C-96-S1									
EAMM-U-70-D40-60G-96										2785471	EAMM-U-70-D40-60G-96									
EAMM-U-70-D40-60G-96-S1										2785542	EAMM-U-70-D40-60G-96-S1									
EAMM-U-70-D40-60H-96										2786101	EAMM-U-70-D40-60H-96									
EAMM-U-70-D40-60H-96-S1										2786137	EAMM-U-70-D40-60H-96-S1									
EAMM-U-70-D40-60P-96										2617488	EAMM-U-70-D40-60P-96									
EAMM-U-70-D40-60P-96-S1										2546123	EAMM-U-70-D40-60P-96-S1									
EAMM-U-70-D40-70A-96										2786204	EAMM-U-70-D40-70A-96									
EAMM-U-70-D40-70A-96-S1										2786316	EAMM-U-70-D40-70A-96-S1									
EAMM-U-86-D40-52B/C-102										86	38	M6	188.5	102.5	38	38	69	16	1537046	EAMM-U-86-D40-52B/C-102
EAMM-U-86-D40-52B/C-102-S1																			1537011	EAMM-U-86-D40-52B/C-102-S1
EAMM-U-86-D40-60G-102	1586445	EAMM-U-86-D40-60G-102																		
EAMM-U-86-D40-60G-102-S1	1586429	EAMM-U-86-D40-60G-102-S1																		
EAMM-U-86-D40-60H-102	1586496	EAMM-U-86-D40-60H-102																		
EAMM-U-86-D40-60H-102-S1	1586372	EAMM-U-86-D40-60H-102-S1																		
EAMM-U-86-D40-70A-102	1212826	EAMM-U-86-D40-70A-102																		
EAMM-U-86-D40-70A-102-S1	1212854	EAMM-U-86-D40-70A-102-S1																		
EAMM-U-86-D40-80P-102	2802441	EAMM-U-86-D40-80P-102																		
EAMM-U-86-D40-80P-102-S1	2802656	EAMM-U-86-D40-80P-102-S1																		
EAMM-U-86-D40-87A-102	1215802	EAMM-U-86-D40-87A-102																		
EAMM-U-86-D40-87A-102-S1	1215814	EAMM-U-86-D40-87A-102-S1																		

# Parallel kits EAMM-U

Technical data



**Dimensions and ordering data**

EGSL-...

Illustration:  
 1 Parallel kit  
 2 Mini slide  
 3 Motor  
 4 Interface for mounting accessories

DNCE-...

Illustration:  
 1 Parallel kit  
 2 Electric cylinder  
 3 Motor  
 4 Interface for mounting accessories  
 5 Only for EAMM-U-...-S1 (with degree of protection IP65)

Download CAD data → [www.festo.com](http://www.festo.com)

Type	B1	B2	D1	H1	H2 ±1	H3	H4	L1	T1 +0.2	Part No.	Type									
EAMM-U-86-D60-52B/C-102	86	56.5	M8	188.5	102.5	38	56.5	71	16	1537000	EAMM-U-86-D60-52B/C-102									
EAMM-U-86-D60-52B/C-102-S1										1431381	EAMM-U-86-D60-52B/C-102-S1									
EAMM-U-86-D60-60G-102										1586347	EAMM-U-86-D60-60G-102									
EAMM-U-86-D60-60G-102-S1										1437163	EAMM-U-86-D60-60G-102-S1									
EAMM-U-86-D60-60H-102										1586276	EAMM-U-86-D60-60H-102									
EAMM-U-86-D60-60H-102-S1										1530837	EAMM-U-86-D60-60H-102-S1									
EAMM-U-86-D60-70A-102										1212477	EAMM-U-86-D60-70A-102									
EAMM-U-86-D60-70A-102-S1										1212835	EAMM-U-86-D60-70A-102-S1									
EAMM-U-86-D60-80P-102										2155875	EAMM-U-86-D60-80P-102									
EAMM-U-86-D60-80P-102-S1										2156527	EAMM-U-86-D60-80P-102-S1									
EAMM-U-86-D60-87A-102										1215784	EAMM-U-86-D60-87A-102									
EAMM-U-86-D60-87A-102-S1										1215810	EAMM-U-86-D60-87A-102-S1									
EAMM-U-110-D60-60G-120										110	56.5	M8	225	120	45	56.5	82	16	1543240	EAMM-U-110-D60-60G-120
EAMM-U-110-D60-60G-120-S1																			1436183	EAMM-U-110-D60-60G-120-S1
EAMM-U-110-D60-60H-120	1542264	EAMM-U-110-D60-60H-120																		
EAMM-U-110-D60-60H-120-S1	1530621	EAMM-U-110-D60-60H-120-S1																		
EAMM-U-110-D60-62B-120	1536988	EAMM-U-110-D60-62B-120																		
EAMM-U-110-D60-62B-120-S1	1431443	EAMM-U-110-D60-62B-120-S1																		
EAMM-U-110-D60-80G-120	1532949	EAMM-U-110-D60-80G-120																		
EAMM-U-110-D60-80G-120-S1	1530875	EAMM-U-110-D60-80G-120-S1																		
EAMM-U-110-D60-100A-120	1202436	EAMM-U-110-D60-100A-120																		
EAMM-U-110-D60-100A-120-S1	1203112	EAMM-U-110-D60-100A-120-S1																		

# Parallel kits EAMM-U

Technical data



Download CAD data → [www.festo.com](http://www.festo.com)

**Dimensions and ordering data**

EGSL-...

Illustration:  
1 Parallel kit  
2 Mini slide  
3 Motor

- - Note  
 The motor can only be mounted on the side and underneath.

DNCE-...

Illustration:  
1 Parallel kit  
2 Electric cylinder  
3 Motor

Type	B1	H1	H2 ±0.1	H3	L1	L2	L3	Part No.	Type
EAMM-U-D32-32B <sup>1)</sup>	45.1	93.1	48	22.6	40	4	-	543152	EAMM-U-D32-32B
EAMM-U-D32-40A								543150	EAMM-U-D32-40A
EAMM-U-D40-42B <sup>1)</sup>	56.5	115	60	28.2	47	4	84	543159	EAMM-U-D40-42B
EAMM-U-D40-42C <sup>1)</sup>							97	543160	EAMM-U-D40-42C
EAMM-U-D40-55A							-	543157	EAMM-U-D40-55A
EAMM-U-D60-52B <sup>1)</sup>	86	162.6	82.5	42.9	58	4	106	543167	EAMM-U-D60-52B
EAMM-U-D60-52C <sup>1)</sup>							120	543168	EAMM-U-D60-52C
EAMM-U-D60-70A							-	543165	EAMM-U-D60-70A

1) Only in combination with DNCE-...

# Parallel kits EAMM-U

Technical data

FESTO

## Dimensions and ordering data

Download CAD data → [www.festo.com](http://www.festo.com)

EGC-...-BS/EGC-HD-...-BS

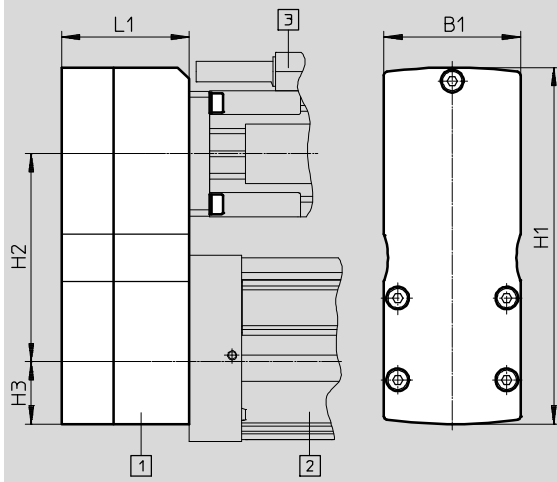

Illustration:

- 1 Parallel kit
- 2 Spindle axis
- 3 Motor

Type	B1	H1	H2 ±1	H3	L1	Part No.	Type
EAMM-U-50-S38-40A-78	50	131	78	25	43	1217708	EAMM-U-50-S38-40A-78
2155239						EAMM-U-50-S38-40P-78	
1217945						EAMM-U-50-S38-42A-78	
EAMM-U-60-S38-40G-91	60	157	91.5	27.5	53	2283732	EAMM-U-60-S38-40G-91
1218538						EAMM-U-60-S38-55A-91	
1218568						EAMM-U-60-S38-57A-91	
EAMM-U-60-S48-40G-91	60	161.5	91.5	32	54	2283760	EAMM-U-60-S48-40G-91
1219370						EAMM-U-60-S48-55A-91	
1219379						EAMM-U-60-S48-57A-91	
EAMM-U-70-S48-60G-96	70	173.5	96	34.5	64.5	2801627	EAMM-U-70-S48-60G-96
2801715						EAMM-U-70-S48-60H-96	
2629253						EAMM-U-70-S48-60P-96	
2787320						EAMM-U-70-S48-70A-96	
EAMM-U-86-S48-60G-102	86	188.5	102.5	38	67	1587251	EAMM-U-60-S48-60G-102
1587338						EAMM-U-60-S48-60H-102	
1217689						EAMM-U-86-S48-70A-102	
EAMM-U-86-S48-87A-177	86	268.5	177.5	43	67	1217604	EAMM-U-86-S48-87A-177
EAMM-U-86-S62-60G-177					69	1587411	EAMM-U-86-S62-60G-177
EAMM-U-86-S62-60H-177						1587453	EAMM-U-86-S62-60H-177
EAMM-U-86-S62-70A-177						1217543	EAMM-U-86-S62-70A-177
EAMM-U-86-S62-80P-177						2157004	EAMM-U-86-S62-80P-177
EAMM-U-86-S62-87A-177						1217373	EAMM-U-86-S62-87A-177
EAMM-U-110-S62-100A-207						110	322.5
EAMM-U-110-S95-80G-207	1589544	EAMM-U-110-S95-80G-207					
EAMM-U-110-S95-100A-207	1220656	EAMM-U-110-S95-100A-207					
EAMM-U-145-S62-140A-288	145	448	288	70	99.5	1219440	EAMM-U-145-S62-140A-288
EAMM-U-145-S95-140A-288						1220582	EAMM-U-145-S95-140A-288

# Parallel kits EAMM-U

Technical data

FESTO

## Dimensions and ordering data

Download CAD data → [www.festo.com](http://www.festo.com)

ESBF-BS-...

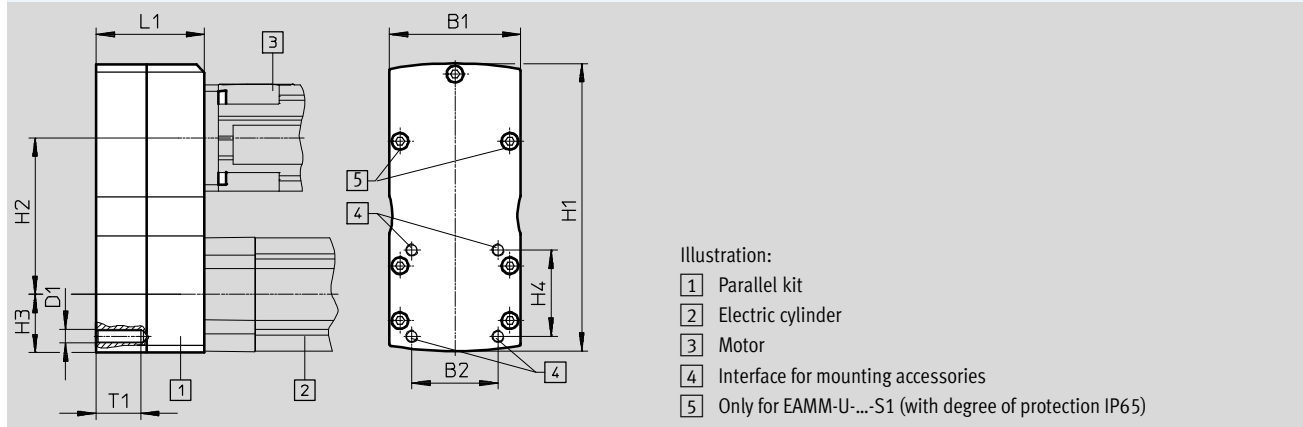

Type	B1	B2	D1	H1	H2 ±1	H3	H4	L1	T1	Part No.	Type	
EAMM-U-50-D32-40A-78	50	32.5	M6	128.8	78	22.8	32.5	45	15	1201591	EAMM-U-50-D32-40A-78	
EAMM-U-50-D32-40A-78-S1										1202302	EAMM-U-50-D32-40A-78-S1	
EAMM-U-50-D32-40P-78										2153283	EAMM-U-50-D32-40P-78	
EAMM-U-50-D32-40P-78-S1										2154009	EAMM-U-50-D32-40P-78-S1	
EAMM-U-50-D32-42A-78										1201607	EAMM-U-50-D32-42A-78	
EAMM-U-50-D32-42A-78-S1	1202312	EAMM-U-50-D32-42A-78-S1										
EAMM-U-60-D32-40G-91	60	32.5	M6	157	91.5	27.5	32.5	56	15	1577358	EAMM-U-60-D32-40G-91	
EAMM-U-60-D32-40G-91-S1										1577346	EAMM-U-60-D32-40G-91-S1	
EAMM-U-60-D32-55A-91										1210126	EAMM-U-60-D32-55A-91	
EAMM-U-60-D32-55A-91-S1										1210450	EAMM-U-60-D32-55A-91-S1	
EAMM-U-60-D32-57A-91										1210419	EAMM-U-60-D32-57A-91	
EAMM-U-60-D32-57A-91-S1		1210453	EAMM-U-60-D32-57A-91-S1									
EAMM-U-60-D40-40G-91		38	M6	157	91.5	27.5	38	56	15	1577165	EAMM-U-60-D40-40G-91	
EAMM-U-60-D40-40G-91-S1										1435968	EAMM-U-60-D40-40G-91-S1	
EAMM-U-60-D40-55A-91										1210438	EAMM-U-60-D40-55A-91	
EAMM-U-60-D40-55A-91-S1										1210458	EAMM-U-60-D40-55A-91-S1	
EAMM-U-60-D40-57A-91	1210442									EAMM-U-60-D40-57A-91		
EAMM-U-60-D40-57A-91-S1	1210462	EAMM-U-60-D40-57A-91-S1										
EAMM-U-70-D32-60G-96	70	32.5	M6	173.5	96	34.5	32.5	64.5	15	2748181	EAMM-U-70-D32-60G-96	
EAMM-U-70-D32-60G-96-S1										2778302	EAMM-U-70-D32-60G-96-S1	
EAMM-U-70-D32-60H-96										2778393	EAMM-U-70-D32-60H-96	
EAMM-U-70-D32-60H-96-S1										2781450	EAMM-U-70-D32-60H-96-S1	
EAMM-U-70-D32-60P-96										2619586	EAMM-U-70-D32-60P-96	
EAMM-U-70-D32-60P-96-S1										2619688	EAMM-U-70-D32-60P-96-S1	
EAMM-U-70-D40-60G-96	70	38	M6	173.5	96	34.5	38	64.5	15	2785471	EAMM-U-70-D40-60G-96	
EAMM-U-70-D40-60G-96-S1										2785542	EAMM-U-70-D40-60G-96-S1	
EAMM-U-70-D40-60H-96										2786101	EAMM-U-70-D40-60H-96	
EAMM-U-70-D40-60H-96-S1										2786137	EAMM-U-70-D40-60H-96-S1	
EAMM-U-70-D40-60P-96										2617488	EAMM-U-70-D40-60P-96	
EAMM-U-70-D40-60P-96-S1		2546123	EAMM-U-70-D40-60P-96-S1									
EAMM-U-70-D40-70A-96		46.5	M8	173.5	96	34.5	46.5	64.5	15	2786204	EAMM-U-70-D40-70A-96	
EAMM-U-70-D40-70A-96-S1										2786316	EAMM-U-70-D40-70A-96-S1	
EAMM-U-70-D50-70A-96										2786899	EAMM-U-70-D40-70A-96	
EAMM-U-70-D50-70A-96-S1										2756078	EAMM-U-70-D40-70A-96-S1	



# Parallel kits EAMM-U

Technical data



## Dimensions and ordering data

Download CAD data → [www.festo.com](http://www.festo.com)

ESBF-BS-...

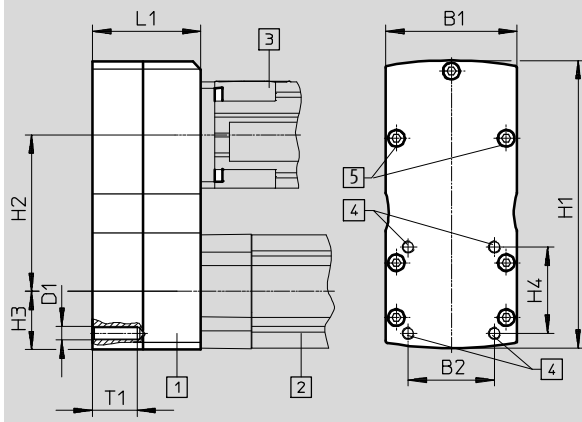

Illustration:

- 1 Parallel kit
- 2 Electric cylinder
- 3 Motor
- 4 Interface for mounting accessories
- 5 Only for EAMM-U-...-S1 (with degree of protection IP65)

Type	B1	B2	D1	H1	H2 ±1	H3	H4	L1	T1	Part No.	Type
EAMM-U-86-D40-60G-102	86	38	M6	188.5	102.5	38	38	69	16	1586445	EAMM-U-86-D40-60G-102
EAMM-U-86-D40-60G-102-S1										1586429	EAMM-U-86-D40-60G-102-S1
EAMM-U-86-D40-60H-102										1586496	EAMM-U-86-D40-60H-102
EAMM-U-86-D40-60H-102-S1										1586372	EAMM-U-86-D40-60H-102-S1
EAMM-U-86-D40-70A-102										1212826	EAMM-U-86-D40-70A-102
EAMM-U-86-D40-70A-102-S1										1212854	EAMM-U-86-D40-70A-102-S1
EAMM-U-86-D40-80P-102										2802441	EAMM-U-86-D40-80P-102
EAMM-U-86-D40-80P-102-S1										2802656	EAMM-U-86-D40-80P-102-S1
EAMM-U-86-D40-87A-102										1215802	EAMM-U-86-D40-87A-102
EAMM-U-86-D40-87A-102-S1										1215814	EAMM-U-86-D40-87A-102-S1
EAMM-U-86-D50-60G-102	86	46.5	M8	188.5	102.5	38	46.5	71	16	2803125	EAMM-U-86-D50-60G-102
EAMM-U-86-D50-60G-102-S1										2803197	EAMM-U-86-D50-60G-102-S1
EAMM-U-86-D50-60H-102										2803326	EAMM-U-86-D50-60H-102
EAMM-U-86-D50-60H-102-S1										2803325	EAMM-U-86-D50-60H-102-S1
EAMM-U-86-D50-80P-102										2803053	EAMM-U-86-D50-80P-102
EAMM-U-86-D50-80P-102-S1										2803073	EAMM-U-86-D50-80P-102-S1
EAMM-U-86-D50-87A-102										2802708	EAMM-U-86-D50-87A-102
EAMM-U-86-D50-87A-102-S1										2802742	EAMM-U-86-D50-87A-102-S1
EAMM-U-110-D50-60G-120	110	46.5	M8	225	120	45	46.5	82	16	2797368	EAMM-U-110-D50-60G-120
EAMM-U-110-D50-60G-120-S1										2798665	EAMM-U-110-D50-60G-120-S1
EAMM-U-110-D50-60H-120										2798760	EAMM-U-110-D50-60H-120
EAMM-U-110-D50-60H-120-S1										2799150	EAMM-U-110-D50-60H-120-S1
EAMM-U-110-D50-80G-120										2799196	EAMM-U-110-D50-80G-120
EAMM-U-110-D50-80G-120-S1										2799281	EAMM-U-110-D50-80G-120-S1
EAMM-U-110-D50-100A-120										2799424	EAMM-U-110-D50-100A-120
EAMM-U-110-D50-100A-120-S1										2799488	EAMM-U-110-D50-100A-120-S1
EAMM-U-86-D60-52B/C-102	86	56.5	M8	188.5	102.5	38	56.5	71	16	1537000	EAMM-U-86-D60-52B/C-102
EAMM-U-86-D60-52B/C-102-S1										1431381	EAMM-U-86-D60-52B/C-102-S1
EAMM-U-86-D60-60G-102										1586347	EAMM-U-86-D60-60G-102
EAMM-U-86-D60-60G-102-S1										1437163	EAMM-U-86-D60-60G-102-S1
EAMM-U-86-D60-70A-102										1212477	EAMM-U-86-D60-70A-102
EAMM-U-86-D60-70A-102-S1										1212835	EAMM-U-86-D60-70A-102-S1
EAMM-U-86-D60-80P-102										2155875	EAMM-U-86-D60-80P-102
EAMM-U-86-D60-80P-102-S1										2156527	EAMM-U-86-D60-80P-102-S1
EAMM-U-86-D60-87A-102										1215784	EAMM-U-86-D60-87A-102
EAMM-U-86-D60-87A-102-S1										1215810	EAMM-U-86-D60-87A-102-S1

# Parallel kits EAMM-U

Technical data

FESTO

## Dimensions and ordering data

Download CAD data → [www.festo.com](http://www.festo.com)

ESBF-BS-...

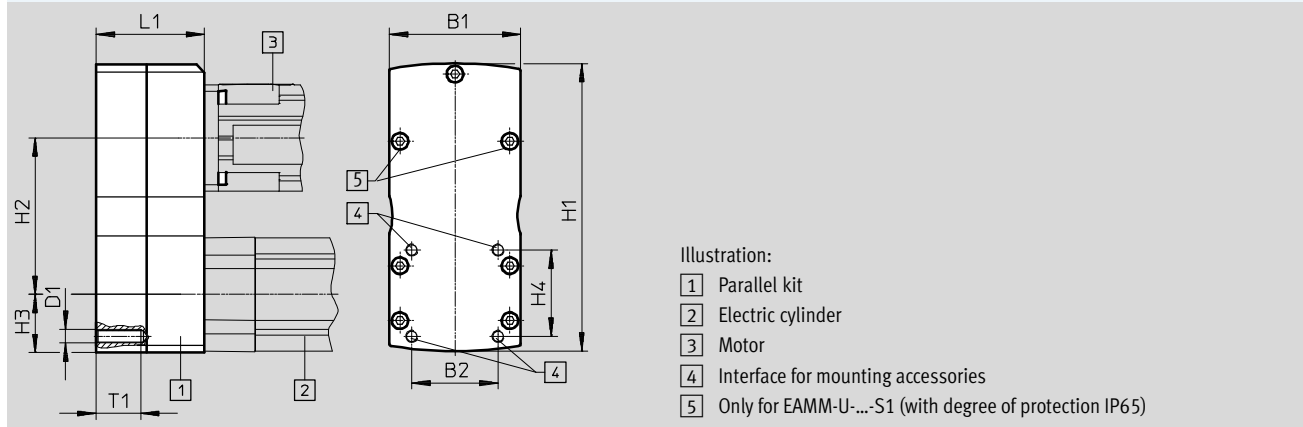

Type	B1	B2	D1	H1	H2 ±1	H3	H4	L1	T1	Part No.	Type
EAMM-U-110-D60-60G-120	110	56.5	M8	225	120	45	56.5	82	16	1543240	EAMM-U-110-D60-60G-120
EAMM-U-110-D60-60G-120-S1										1436183	EAMM-U-110-D60-60G-120-S1
EAMM-U-110-D60-60H-120										1542264	EAMM-U-110-D60-60H-120
EAMM-U-110-D60-60H-120-S1										1530621	EAMM-U-110-D60-60H-120-S1
EAMM-U-110-D60-62B-120										1536988	EAMM-U-110-D60-62B-120
EAMM-U-110-D60-62B-120-S1										1431443	EAMM-U-110-D60-62B-120-S1
EAMM-U-110-D60-80G-120										1532949	EAMM-U-110-D60-80G-120
EAMM-U-110-D60-80G-120-S1										1530875	EAMM-U-110-D60-80G-120-S1
EAMM-U-110-D60-100A-120										1202436	EAMM-U-110-D60-100A-120
EAMM-U-110-D60-100A-120-S1										1203112	EAMM-U-110-D60-100A-120-S1
EAMM-U-110-D80-80G-120	110	72	M10	235	120	55	72	82	20.5	1589614	EAMM-U-110-D80-80G-120
EAMM-U-110-D80-80G-120-S1										1589706	EAMM-U-110-D80-80G-120-S1
EAMM-U-110-D80-100A-120										1465438	EAMM-U-110-D80-100A-120
EAMM-U-110-D80-100A-120-S1										1433650	EAMM-U-110-D80-100A-120-S1
EAMM-U-145-D80-140A-188	145	72	M10	348	188	70	72	99.5	25	1465530	EAMM-U-145-D80-140A-188
EAMM-U-145-D80-140A-188-S1										1433709	EAMM-U-145-D80-140A-188-S1
EAMM-U-145-D100-120G-188	145	89	M10	348	188	70	89	99.5	25	2803620	EAMM-U-145-D100-120G-188
EAMM-U-145-D100-120G-188-S1										2803622	EAMM-U-145-D100-120G-188-S1
EAMM-U-145-D100-140A-188										1465541	EAMM-U-145-D100-140A-188
EAMM-U-145-D100-140A-188-S1										1433852	EAMM-U-145-D100-140A-188-S1

# Parallel kits EAMM-U

Technical data

**Dimensions**

Download CAD data → [www.festo.com](http://www.festo.com)

DGE-SP-...

Illustration:  
1 Parallel kit  
2 Spindle axis  
3 Motor

DMES-...

Illustration:  
1 Parallel kit  
2 Positioning axis  
3 Motor

Type	B1	H1	H2	H3	L1	L2	L3	Part No.	Type
EAMM-U-E24-32B <sup>1)</sup>	43.3	110.05	69 <sub>-0.1</sub>	21.7	39	-	-	543225	EAMM-U-E24-32B
EAMM-U-E24-40A <sup>1)</sup>								543226	EAMM-U-E24-40A
EAMM-U-E32-42B	56.4	132.7	76.5 <sub>-0.1</sub>	28.2	47	53.5	84	543228	EAMM-U-E32-42B
EAMM-U-E32-42C							97	543229	EAMM-U-E32-42C
EAMM-U-E32-55A							-	543230	EAMM-U-E32-55A
EAMM-U-E48-52B	85.8	189.9	107.5 <sub>-0.2</sub>	42.9	58	66.5	106	543232	EAMM-U-E48-52B
EAMM-U-E48-52C							120	543233	EAMM-U-E48-52C
EAMM-U-E48-70A							-	543234	EAMM-U-E48-70A

1) Only in combination with DMES-...

## Parallel kits EAMM-U

Accessories

FESTO

### Clamping component EADT

Materials:

Plastic

RoHS-compliant

For adjusting the toothed belt pretension with EAMM-U-110 and EAMM-U-145.

The motor is pushed away from the axis mechanism by turning the clamping component secured in a hole in the housing (the motor can be moved in a slot for this purpose).

This enables high toothed belt pretension forces to be generated with low torques at the clamping component.

Can only be used in combination with a parallel kit as per the illustrations (→ page 3 ... 9).

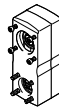

### Ordering data

Type	Ambient temperature [°C]	Weight [g]	Part No.	Type
EADT-E-U1-110	-10 ... +60	9	1461069	EADT-E-U1-110

### Counter bearing EAMG

Materials:

Wrought aluminium alloy

RoHS-compliant

A counter bearing EAMG reduces the load on the axis or motor bearings to improve the service life under high loads. A clamping sleeve EAMH-...-P is additionally required for each counter bearing.

Can only be used in combination with a parallel kit as per the illustrations (→ page 3 ... 9).

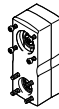

### Ordering data

Type	For size	Max. rotational speed [rpm]	Ambient temperature [°C]	Weight [g]	Part No.	Type
EAMG-U1-50	50	6000	-10 ... +60	20	1354281	EAMG-U1-50
EAMG-U1-60	60	6000		35	1354282	EAMG-U1-60
EAMG-U1-70	70	5000		74	2598638	EAMG-U1-70
EAMG-U1-86	86	5000		83	1354283	EAMG-U1-86
EAMG-U1-110	110	5000		169	1354284	EAMG-U1-110
EAMG-U1-145	145	4000		186	1354285	EAMG-U1-145

# Parallel kits EAMM-U

Accessories



## Clamping sleeve EAMH-...-P, with trunnion

Materials:

Corrosion-resistant steel

RoHS-compliant

To retrofit the counter bearing, the clamping sleeve without trunnion included as standard in the parallel kit must be replaced by the clamping sleeve EAMH-...-P with integrated trunnion. The appropriate clamping sleeve size for the counter bearing is determined by the size of the parallel kit.

Can only be used in combination with a parallel kit as per the illustrations (→ page 3 ... 9).

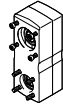

Ordering data								
Type	For size	For shaft Ø, motor/axis Ø h7 ... k7	Max. rotational speed [rpm]	Mass moment of inertia [kg mm <sup>2</sup> ]	Ambient temperature [°C]	Weight [g]	Part No.	Type
EAMH-50-5-C13.6-P	50	5	6000	0.39	-10 ... +60	20	1354092	EAMH-50-5-C13.6-P
EAMH-50-6-C13.6-P	50	6	6000	0.38		19	1354093	EAMH-50-6-C13.6-P
EAMH-50-8-C13.6-P	50	8	6000	0.35		16	1354094	EAMH-50-8-C13.6-P
EAMH-60-6-C18.1-P	60	6	6000	1.57		44	1354095	EAMH-60-6-C18.1-P
EAMH-60-6.35-C18.1-P	60	6.35	6000	1.56		43	1354096	EAMH-60-6.35-C18.1-P
EAMH-60-8-C18.1-P	60	8	6000	1.53		41	1354097	EAMH-60-8-C18.1-P
EAMH-60-9-C18.1-P	60	9	6000	1.5		39	1354098	EAMH-60-9-C18.1-P
EAMH-60-10-C18.1-P	60	10	6000	1.4		38	1545242	EAMH-60-10-C18.1-P
EAMH-60-11-C18.1-P	60	11	6000	1.31		35	2789343	EAMH-60-11-C18.1-P
EAMH-60-12-C18.1-P	60	12	6000	1.3		32	1354099	EAMH-60-12-C18.1-P
EAMH-86-6-C27.3-P	70, 86	6	5000	12.3		123	2789351	EAMH-86-6-C27.3-P
EAMH-86-8-C27.3-P	70, 86	8	5000	10.3		128	1354100	EAMH-86-8-C27.3-P
EAMH-86-9-C27.3-P	70, 86	9	5000	9		117	2789359	EAMH-86-9-C27.3-P
EAMH-86-10-C27.3-P	70, 86	10	5000	9		115	2789365	EAMH-86-10-C27.3-P
EAMH-86-11-C27.3-P	70, 86	11	5000	10.1		119	1354101	EAMH-86-11-C27.3-P
EAMH-86-12-C27.3-P	70, 86	12	5000	10		115	1354102	EAMH-86-12-C27.3-P
EAMH-86-14-C27.3-P	70, 86	14	5000	8.74		103	1459337	EAMH-86-14-C27.3-P
EAMH-86-16-C27.3-P	70, 86	16	5000	8.3		95	2430402	EAMH-86-16-C27.3-P
EAMH-86-19-C27.3-P	70, 86	19	5000	7.1		78	2406019	EAMH-86-19-C27.3-P
EAMH-110-11-C34-P	110	11	5000	33.2		270	1545245	EAMH-110-11-C34-P
EAMH-110-12-C34-P	110	12	5000	36.3	278	1354103	EAMH-110-12-C34-P	
EAMH-110-14-C34-P	110	14	5000	35.8	267	1354104	EAMH-110-14-C34-P	
EAMH-110-16-C34-P	110	16	5000	35.1	254	1354105	EAMH-110-16-C34-P	
EAMH-110-19-C34-P	110	19	5000	33.3	230	1354106	EAMH-110-19-C34-P	
EAMH-110-20-C34-P	110	20	5000	30.2	217	1545246	EAMH-110-20-C34-P	
EAMH-110-22-C34-P	110	22	5000	28.3	200	2430414	EAMH-110-22-C34-P	
EAMH-110-25-C34-P	110	25	5000	25.8	170	1354107	EAMH-110-25-C34-P	
EAMH-145-12-C34-P	145	12	4000	43.9	338	1354108	EAMH-145-12-C34-P	
EAMH-145-19-C34-P	145	19	4000	38	281	1459342	EAMH-145-19-C34-P	
EAMH-145-24-C34-P	145	24	4000	34	229	1354109	EAMH-145-24-C34-P	
EAMH-145-25-C34-P	145	25	4000	32.1	217	1354110	EAMH-145-25-C34-P	

# Parallel kits EAMM-U

Accessories



## Clamping sleeve EAMH, without trunnion

Materials:

Corrosion-resistant steel

RoHS-compliant

Clamping sleeves for adapting third-party motors with deviating shaft diameters on the parallel kits.

Can only be used in combination with a parallel kit as per the illustrations (→ page 3 ... 9).

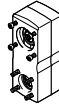

Ordering data								
Type	For size	For shaft Ø, motor/axis Ø h7 ... k7	Max. rotational speed [rpm]	Mass moment of inertia [kg mm <sup>2</sup> ]	Ambient temperature [°C]	Weight [g]	Part No.	Type
EAMH-50-5-C13.6	50	5	6000	0.44	-10 ... +60	19	2428478	EAMH-50-5-C13.6
EAMH-50-6-C13.6	50	6	6000	0.43		19	2428479	EAMH-50-6-C13.6
EAMH-50-8-C13.6	50	8	6000	0.40		16	2428480	EAMH-50-8-C13.6
EAMH-60-6-C18.1	60	6	6000	1.46		36	2428515	EAMH-60-6-C18.1
EAMH-60-6.35-C18.1	60	6.35	6000	1.46		36	2428516	EAMH-60-6.35-C18.1
EAMH-60-8-C18.1	60	8	6000	1.44		34	2428517	EAMH-60-8-C18.1
EAMH-60-9-C18.1	60	9	6000	1.42		32	2428518	EAMH-60-9-C18.1
EAMH-60-10-C18.1	60	10	6000	1.38		30	2428519	EAMH-60-10-C18.1
EAMH-60-11-C18.1	60	11	6000	1.31		28	2789160	EAMH-60-11-C18.1
EAMH-60-12-C18.1	60	12	6000	1.22		26	2428520	EAMH-60-12-C18.1
EAMH-86-6-C27.3	70, 86	6	5000	10.2		122	2789214	EAMH-86-6-C27.3
EAMH-86-8-C27.3	70, 86	8	5000	10.3		119	2429531	EAMH-86-8-C27.3
EAMH-86-9-C27.3	70, 86	9	5000	11.6		116	2789221	EAMH-86-9-C27.3
EAMH-86-10-C27.3	70, 86	10	5000	10.1		114	2789230	EAMH-86-10-C27.3
EAMH-86-11-C27.3	70, 86	11	5000	10.2		112	2429532	EAMH-86-11-C27.3
EAMH-86-12-C27.3	70, 86	12	5000	10.1		109	2429533	EAMH-86-12-C27.3
EAMH-86-14-C27.3	70, 86	14	5000	9.9		102	2429534	EAMH-86-14-C27.3
EAMH-86-16-C27.3	70, 86	16	5000	9.5		94	2430397	EAMH-86-16-C27.3
EAMH-86-19-C27.3	70, 86	19	5000	8.2		76	2429535	EAMH-86-19-C27.3
EAMH-110-11-C34	110	11	5000	32.2		233	2429555	EAMH-110-11-C34
EAMH-110-12-C34	110	12	5000	32.1	229	2429556	EAMH-110-12-C34	
EAMH-110-14-C34	110	14	5000	31.8	219	2429557	EAMH-110-14-C34	
EAMH-110-16-C34	110	16	5000	31.2	208	2429558	EAMH-110-16-C34	
EAMH-110-19-C34	110	19	5000	29.9	188	2429559	EAMH-110-19-C34	
EAMH-110-20-C34	110	20	5000	29.2	180	2429560	EAMH-110-20-C34	
EAMH-110-22-C34	110	22	5000	27.3	162	2430411	EAMH-110-22-C34	
EAMH-110-25-C34	110	25	5000	23.4	133	2429561	EAMH-110-25-C34	
EAMH-145-12-C34	145	12	4000	38.1	274	2429590	EAMH-145-12-C34	
EAMH-145-19-C34	145	19	4000	35.5	227	2429591	EAMH-145-19-C34	
EAMH-145-24-C34	145	24	4000	30.0	177	2429592	EAMH-145-24-C34	
EAMH-145-25-C34	145	25	4000	28.1	165	2429593	EAMH-145-25-C34	

# Parallel kits EAMM-U

Accessories



## Seal set

RoHS-compliant

Spare part for degree of protection to IP65. Seal between motor and parallel kit.

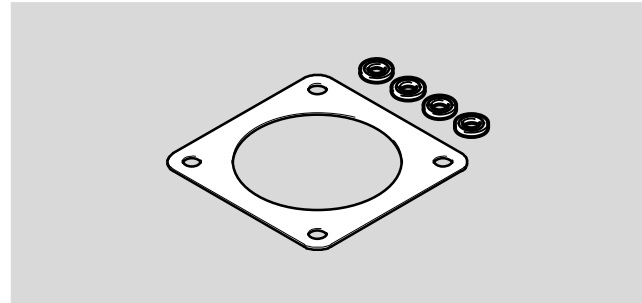

Ordering data				
Type	For parallel kit	Ambient temperature [°C]	Part No.	Type
EADS-F-40A	EAMM-U-50-D32-40A-78-S1	-25 ... +60	2481474	EADS-F-40A
EADS-F-40P	EAMM-U-50-D32-40P-78-S1		2481475	EADS-F-40P
EADS-F-42A	EAMM-U-50-D32-42A-78-S1		2481476	EADS-F-42A
EADS-F-55A	EAMM-U-60-D32-55A-91-S1 EAMM-U-60-D40-55A-91-S1		2481477	EADS-F-55A
EADS-F-57A	EAMM-U-60-D32-57A-91-S1 EAMM-U-60-D40-57A-91-S1		2481478	EADS-F-57A
EADS-F-60P	EAMM-U-70-D32-60P-96-S1 EAMM-U-70-D40-60P-96-S1		2481479	EADS-F-60P
EADS-F-70A	EAMM-U-70-D32-70A-96-S1 EAMM-U-70-D40-70A-96-S1 EAMM-U-86-D40-70A-102-S1 EAMM-U-86-D60-70A-102-S1		2481480	EADS-F-70A
EADS-F-80P	EAMM-U-86-D40-80P-102-S1 EAMM-U-86-D50-80P-102-S1 EAMM-U-86-D60-80P-102-S1		2481481	EADS-F-80P
EADS-F-87A	EAMM-U-86-D40-87A-102-S1 EAMM-U-86-D50-87A-102-S1 EAMM-U-86-D60-87A-102-S1		2481482	EADS-F-87A
EADS-F-100A	EAMM-U-110-D50-100A-120-S1 EAMM-U-110-D60-100A-120-S1 EAMM-U-110-D80-100A-120-S1		2481483	EADS-F-100A
EADS-F-140A	EAMM-U-145-D80-140A-188-S1 EAMM-U-145-D100-140A-188-S1		2481484	EADS-F-140A