



- Wide variety of mounting options
- Infinitely adjustable swivel angle
- Comprehensive range of accessories

# Semi-rotary drives DSR/DSRL

Features

FESTO

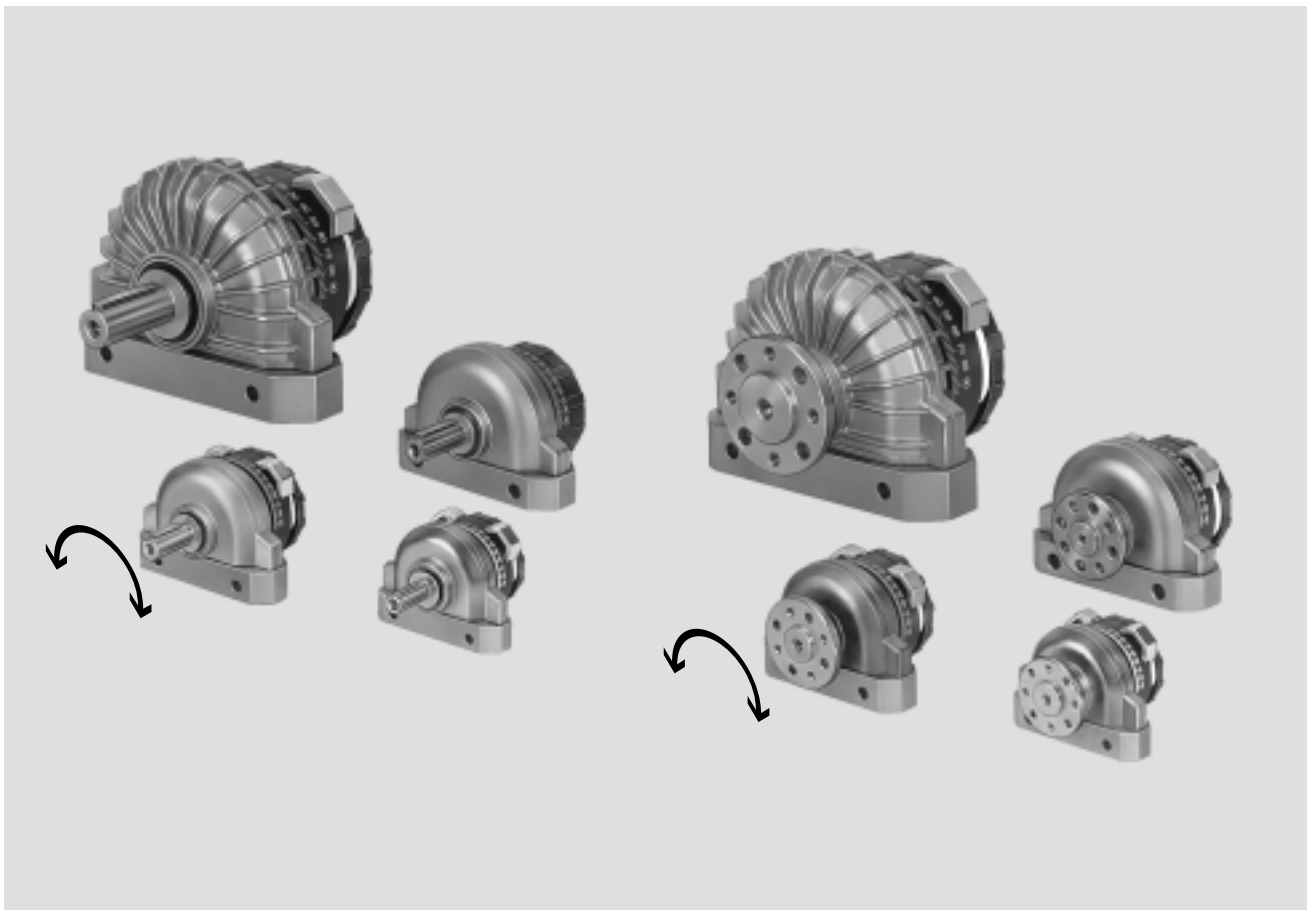

## Brief description

In these semi-rotary drives, the force is directly transmitted to the drive shaft via a rotary vane. The swivel angle is infinitely adjustable from 0 ... 184° (DSRL-10 and 12: 0 ... 181°).

The adjustable stop system is separate from the rotary vane so that any forces which occur are absorbed by the stop blocks. The impacts are cushioned at the end positions by flexible plastic plates.

**DSRL-...-FW**  
This design with hollow flanged shaft permits the passage of liquid or gaseous media, or even tubing or

wiring. The force is transmitted directly and backlash-free via a splined shaft.

-  - Note  
Sizing software  
Calculating inertia  
→ [www.festo.com](http://www.festo.com)

# Semi-rotary drives DSR/DSRL

Features

## Mounting options

Without mounting attachments

Direct mounting

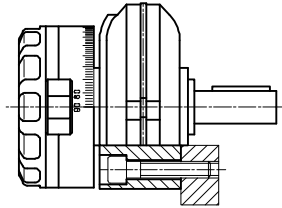

With mounting attachments for DSR

Foot mounting HSR-...-FW



Flange mounting FSR



Push-on flange FWSR



for DSRL

Foot mounting HSR-...-FW



## Freewheel unit for synchronous movements

The freewheel unit is an attachment which is fitted to the drive shaft of the semi-rotary drive DSR. The freewheel unit converts the oscillating rotary movement of the semi-rotary drive into a synchronous, indexing movement. The movement of the semi-rotary drive shaft only occurs in the working directions left or right. This permits infinitely adjustable feed movements.

The minimum possible swivel angle is 0.4°. Switching accuracy is also dependent upon switching speed and load.

-  - Note

The load must be stopped externally!

FLSR-...-L (left-hand)  
Viewed from the drive shaft side, rotation counter-clockwise.

FLSR-...-R (right-hand)  
Viewed from the drive shaft side, rotation clockwise.

Accessories  
Speed regulation

→ 20

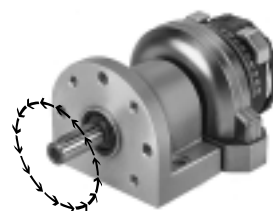

FLSR with semi-rotary drive

## Sample applications with hollow flanged shaft in DSRL

Air blast

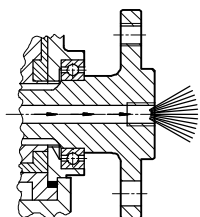

Vacuum

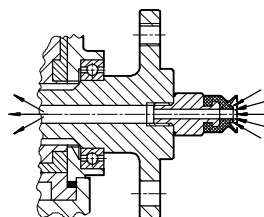

Electrical lines

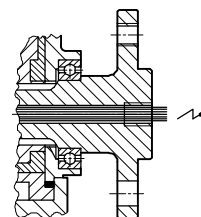

Water, coolant, oil, glue, etc.

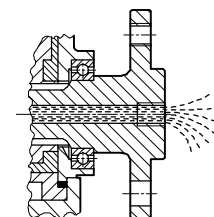

- 7 - Type discontinued SR-3-E-SW  
Available up until 2015

FESTO

## Semi-rotary drives DSR/DSRL

Peripherals overview and type codes

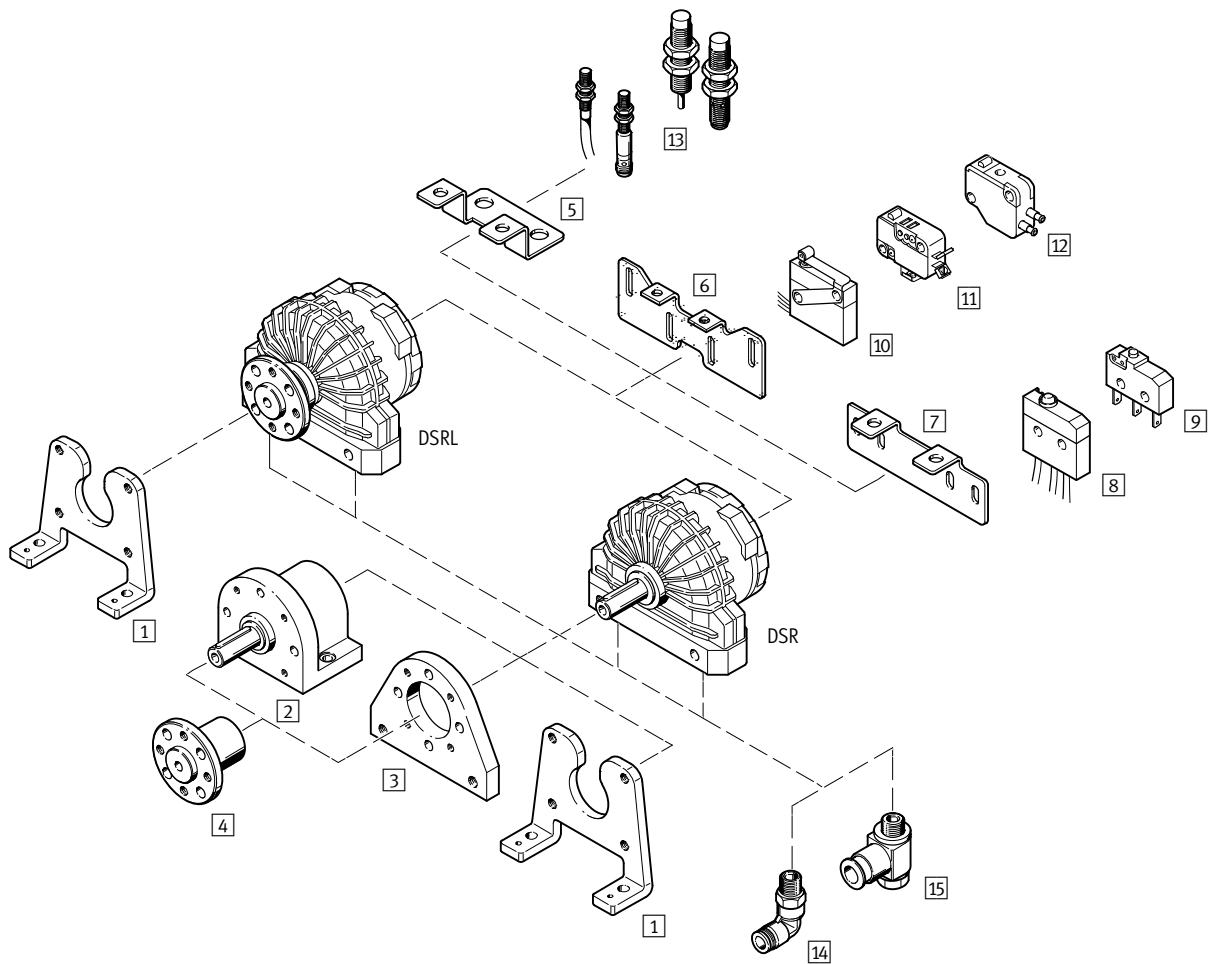

## Semi-rotary drives DSR/DSRL

Peripherals overview and type codes

Mounting attachments and accessories				
	Brief description	DSR	DSRL	→ Page/Internet
1	Foot mounting HSR-...-FW	■	■	12
2	Freewheel unit FLSR-...-L/R	■	-	14
3	Flange mounting FSR	■	-	12
4	Push-on flange FWSR	■	-	13
5	Mounting kit WSR-...	■	■	17
6	Mounting kit WSR-12 ... 40	■	■	16
7	Mounting kit WSR-10/12-K	■	■	16
8	Micro switch S-3-BE-SW	■	■	19
9	Micro switch S-3-BE	■	■	19
10	Micro switch SR-3-E-SW	■	■	19
11	Micro switch S-3-E	■	■	19
12	Micro stem actuated valve SO-3-PK-3-B, S-3-PK-3-B	■	■	20
13	Proximity sensors SIEN	■	■	20
14	Push-in L-fitting QSL	■	■	quick star
15	One-way flow control valve GRLA	■	■	20

DSRL		-	10	-	180	-	P	-	FW
<b>Type</b>									
Double-acting									
DSR	Semi-rotary drive with spigot shaft								
DSRL	Semi-rotary drive, with flanged, hollow drive shaft								
<b>Piston Ø [mm]</b>									
<b>Swivel angle [°]</b>									
<b>Cushioning</b>									
P	Non-adjustable at either end								
<b>Shaft</b>									
	Spigot shaft								
FW	Drive shaft								

# Semi-rotary drives DSR/DSRL

Technical data

Function

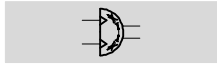

Variants

- With spigot shaft
- With hollow flanged shaft

- Ø - Diameter  
10 ... 40 mm

- ≡ - Force  
0.5 ... 20 Nm

- T - www.festo.com



General technical data						
Piston Ø	10	12	16	25	32	40
Pneumatic connection	M3	M5	M5	M5	G $\frac{1}{8}$	G $\frac{1}{4}$
Design	Semi-rotary actuator with vane drive					
Cushioning	Non-adjustable at either end					
Position sensing	Electrical					
	Pneumatic					
	Inductive					
Type of mounting	Via through-holes					
	Via accessories					
Mounting position	Any					
Max. swivel angle	0 ... 181 °		0 ... 184 °			

- | - Note: This product conforms to ISO 1179-1 and to ISO 228-1

Operating and environmental conditions						
Piston Ø	10	12	16	25	32	40
Operating medium	Compressed air in accordance with ISO 8573-1:2010 [7:--]					
Operating pressure [bar]	2.5 ... 8	2 ... 8	1.5 ... 8			
Temperature range <sup>1)</sup> [°C]	-10 ... +60					

1) Note operating range of proximity sensors

Forces and torques						
Piston Ø	10	12	16	25	32	40
Torque at 6 bar [Nm]	0.5	1	2	5	10	20
Max. swivelling frequency <sup>1)</sup> [Hz]	3					
Max. perm. radial load <sup>2)</sup> [N]	30	45	75	120	200	350
Max. perm. axial load <sup>2)</sup> [N]	10	18	30	50	75	120
Max. perm. mass moment of inertia <sup>2)</sup>	Diagrams → 8					

- 1) Please observe the max. permissible mass moments of inertia → 8  
 2) On the drive shaft at maximum frequency

# Semi-rotary drives DSR/DSRL

Technical data

## Materials

Sectional view

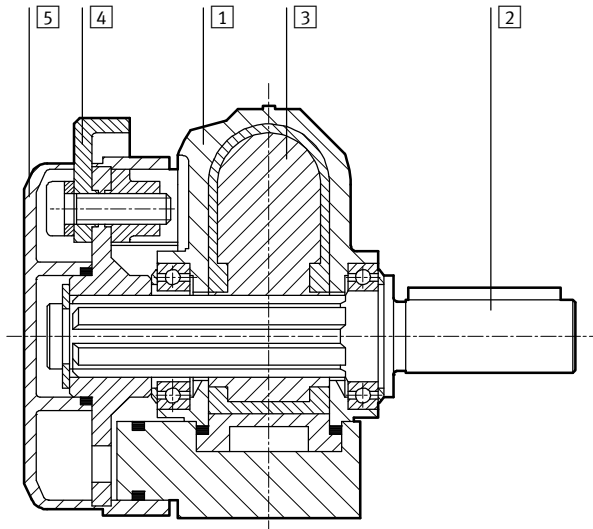

Rotary actuator	
1	Housing Die-cast zinc
2	Drive shaft Nickel plated steel
3	Rotary vane Plastic
4	Trip cam Sintered steel, nickel plated
5	Cover cap Plastic
-	Seals Nitrile rubber

Weights [g]						
Piston Ø	10	12	16	25	32	40
DSR-...-P	100	200	310	540	1,285	2,400
DSRL-...-FW	140	240	350	610	1,390	2,700

# Semi-rotary drives DSR/DSRL

Technical data



## Max. permissible mass moment of inertia

Mass moment of inertia  $m$  as a function of swivel time  $S$  and swivel angle

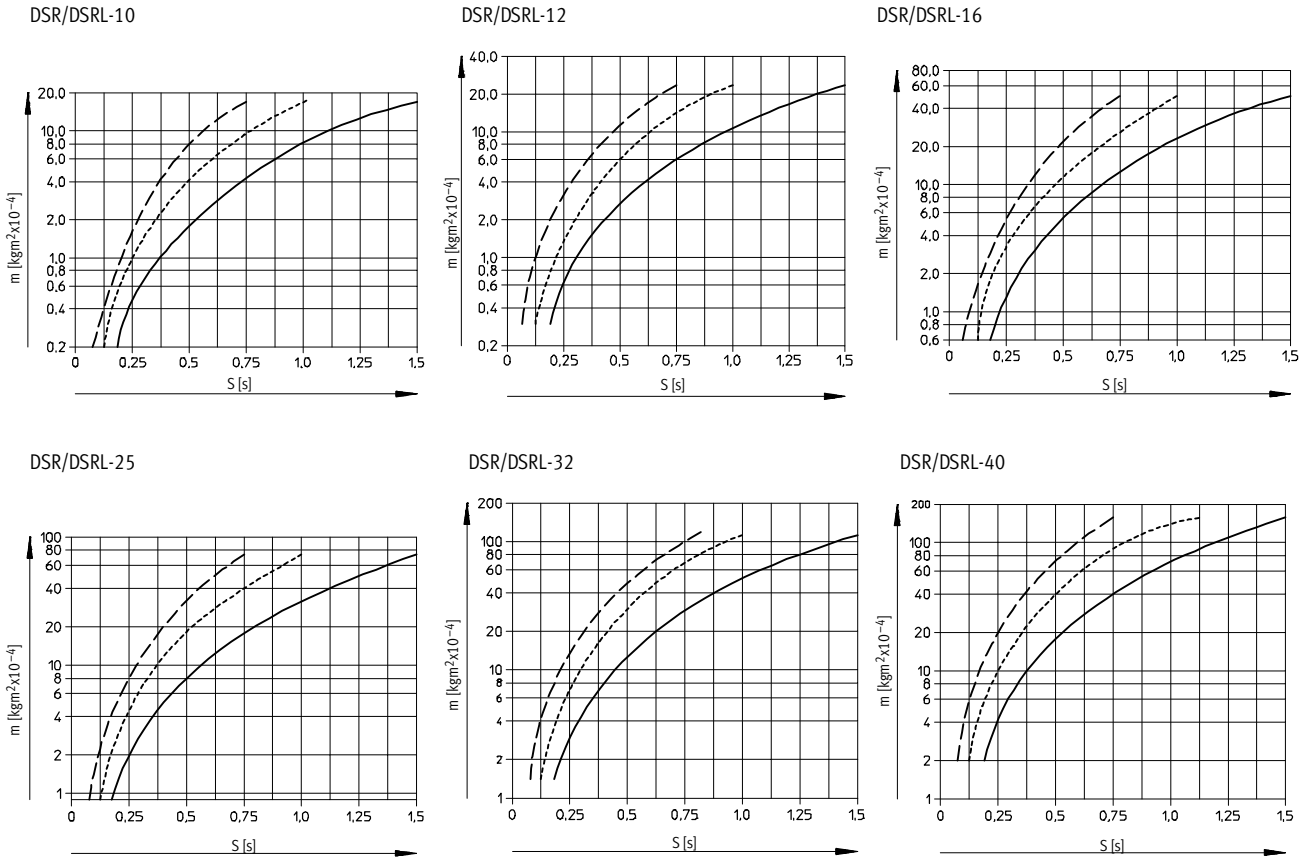

- - Note  
Sizing software  
Calculating inertia  
→ [www.festo.com](http://www.festo.com)

----- Swivel angle 90°  
..... Swivel angle 120°  
———— Swivel angle 180°

### Assembly instructions:

If the listed maximum permissible mass moment of inertia is exceeded, external stops must be attached.

Please note:

The stop must not be less than the minimum radius to the drive shaft ( $r_{min}$ ). The stop force must not exceed

the maximum force. Due to the flexibility of the stops, a precise end position can only be achieved using external stops.

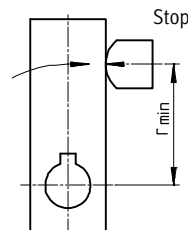

∅	Stop radius	Force
[mm]	$r_{min}$ [mm]	[N]
10	13	60
12	15	90
16	17	160
25	21	320
32	28	480
40	40	650

- - Note  
When throttling the semi-rotary drives to swivelling speeds under 180°/s, the drives must be operated

at a pressure of at least 6 bar. A constant speed fluctuation of ±30 % is to be expected. The flutters and the

swivelling times shown in the diagrams can only be improved by using flow control valves.



# Semi-rotary drives DSR/DSRL

Technical data

FESTO

## Dimensions

DSR

Download CAD data → [www.festo.com](http://www.festo.com)

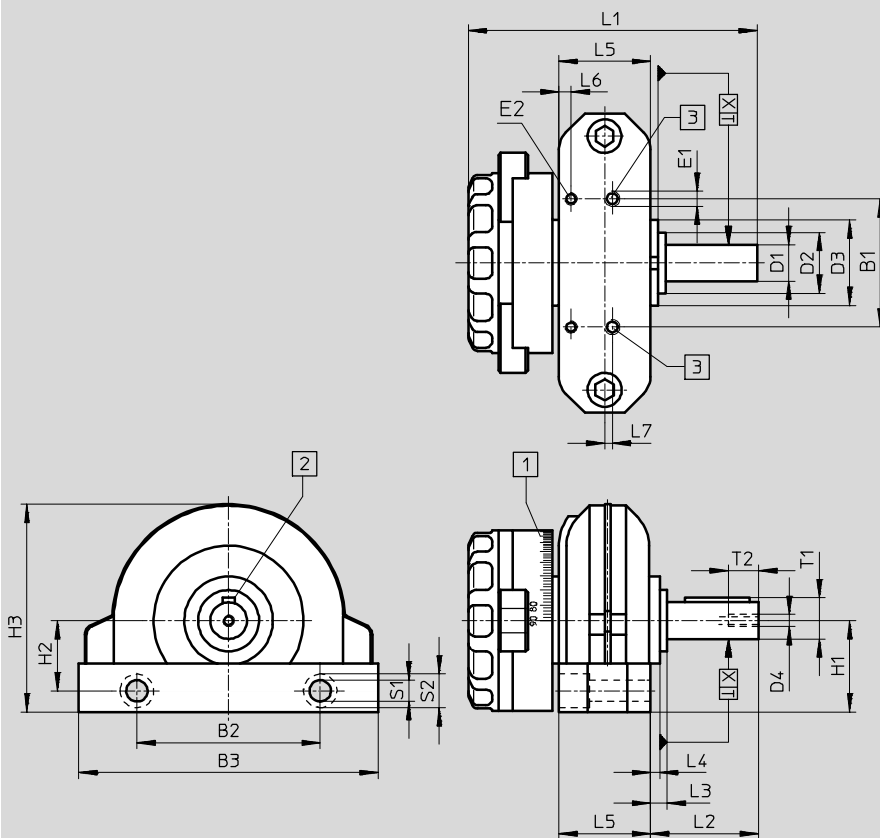

Note

The swivel angle is 180° and pressure-dependent. The cushioning angle on each side is approx. 1.6° maximum at 8 bar.

If after the swivel process, the kinetic energy is converted by cushioning, the drive shaft swivels back by a corresponding angle.

The stops must not be removed as the rotary vane is not suitable for end-position limiting. The cover cap is equipped with an angle scale for adjusting.

When attaching additional components to the drive shaft, the maximum permissible tightening torque of the bolt at D4 must not be exceeded.

- 1) Angle scale for swivel angle reading      2) Woodruff key position at 0°      3) Supply port

∅	B1	B2	B3	D1	D2	D3	D4	E1	E2	H1	H2	H3	L1	L2
[mm]				∅ g7	∅	∅ h8								
10	22	32	53	6	12	20	M2.5	M3	M3	19.4	15.5	38.8	57	22.4
12	26	40	65	8	16	22	M3	M5	M3	23.5	18.5	48	65.6	25.5
16	30	46	78	10	17	24	M3	M5	M3	27	20.5	56.5	75.8	29
25	42	60	98	12	18	28	M4	M5	M4	30	23	68.1	94.5	35.4
32	54	80	130	16	27	42	M5	G1/8	M4	43	34	92	125.5	50
40	70	100	160	20	36	52	M6	G1/4	M4	53	40	121	162	60

∅	L3	L4	L5	L6	L7	S1	S2	T1	T2	X	Woodruff key to DIN 6885 <sup>1)</sup>	Tightening torque at D4 [Nm]
[mm]												
10	6.5	4.5	15.1	2.2	2	3.4	6	6.8	7	0.35	A2 x 2 x 12	0.7
12	5.5	3.5	18	2.1	2.5	4.4	8	8.8	9	0.35	A2 x 2 x 16	1.2
16	6	3.5	22.5	2.1	–	5.5	10	11.2	9	0.35	A3 x 3 x 18	1.2
25	5.4	3	30	4	–	7	11	13.5	10	0.4	A4 x 4 x 25	5.5
32	10	7	36	4	–	8.5	15	18	12.5	0.45	A5 x 5 x 36	5.5
40	10	6	50	4	–	8.5	15	22.5	16	0.5	A6 x 6 x 45	5.5

1) included in scope of delivery

Note: This product conforms to ISO 1179-1 and to ISO 228-1

# Semi-rotary drives DSR/DSRL

Technical data

FESTO

## Dimensions

Download CAD data → [www.festo.com](http://www.festo.com)

### DSRL

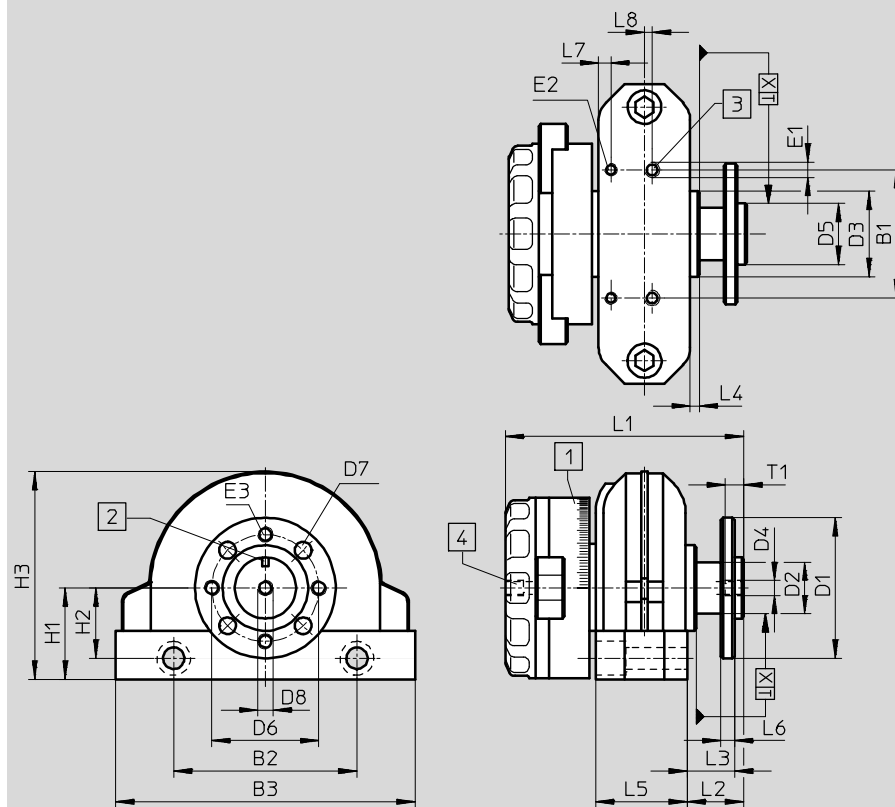

Note

The swivel angle is 180° and pressure-dependent. The cushioning angle on each side is approx. 1.6° maximum at 8 bar.

If after the swivel process, the kinetic energy is converted by cushioning, the drive shaft swivels back by a corresponding angle.

The stops must not be removed as the rotary vane is not suitable for end-position limiting. The cover cap is equipped with an angle scale for adjusting.

When attaching additional components to the drive flange, the maximum permissible tightening torque of the bolt at D4 must not be exceeded.

- 1 Angle scale for swivel angle reading
- 2 Position of marking at angle scale 0°
- 3 Supply port
- 4 Through-hole



∅	B1	B2	B3	D1	D2	D3	D4	D5	D6	D7	D8	E1	E2	E3	H1
[mm]				∅	∅	∅ h8		∅ f8	∅	∅ H13	∅ min.				
10	22	32	53	30	10	20	M3	11	21	3.4	1.5	M3	M3	M3	19.4
12	26	40	65	33	13	22	M3	14	25	3.4	1.5	M5	M3	M3	23.5
16	30	46	78	38	14	24	M5	16	28	4.5	3.5	M5	M3	M4	27
25	42	60	98	46	17	28	M5	20	35	5.5	3.5	M5	M4	M5	30
32	54	80	130	60	24	42	G $\frac{1}{8}$	28	45	6.5	7	G $\frac{1}{8}$	M4	M6	43
40	70	100	160	70	30	52	G $\frac{1}{8}$	36	54	9	7	G $\frac{1}{4}$	M4	M8	53

∅	H2	H3	L1	L2	L3	L4	L5	L6	L7	L8	S1	S2	T1	X	Tightening torque at D4 [Nm]
[mm]															
10	15.5	38.8	49	14	12.3	4.5	15.1	3	2.2	2	3.4	6	5	0.35	0.7
12	18.5	48	54.2	13.5	11.5	3.5	18	3	2.1	2.5	4.4	8	5	0.35	1.2
16	20.5	56.5	64.7	16	14	3.5	22.5	4	2.1	-	5.5	10	6	0.35	1.2
25	23	68.1	78	18.5	15.5	3	30	4.5	4	-	7	11	6	0.4	5.5
32	34	92	102.8	26	22	7	36	6	4	-	8.5	15	8	0.45	5.5
40	40	121	134.5	31	26	6	50	7.5	4	-	8.5	15	8	0.5	5.5

Note: This product conforms to ISO 1179-1 and to ISO 228-1

# Semi-rotary drives DSR/DSRL

Technical data

Ordering data				
Rotary actuator	Design	∅ [mm]	Part No.	Type
DSR-...-P				
	With spigot shaft	10	33 297	DSR-10-180-P
		12	11 909	DSR-12-180-P
		16	11 910	DSR-16-180-P
		25	11 911	DSR-25-180-P
		32	11 912	DSR-32-180-P
		40	13 467	DSR-40-180-P
DSRL-...-P-FW				
	With hollow flanged shaft	10	33 296	DSRL-10-180-P-FW
		12	30 654	DSRL-12-180-P-FW
		16	30 655	DSRL-16-180-P-FW
		25	30 656	DSRL-25-180-P-FW
		32	30 657	DSRL-32-180-P-FW
		40	30 658	DSRL-40-180-P-FW

# Semi-rotary drives DSR/DSRL

Accessories

FESTO

## Foot mounting HSR-...-FW

Material:  
Steel

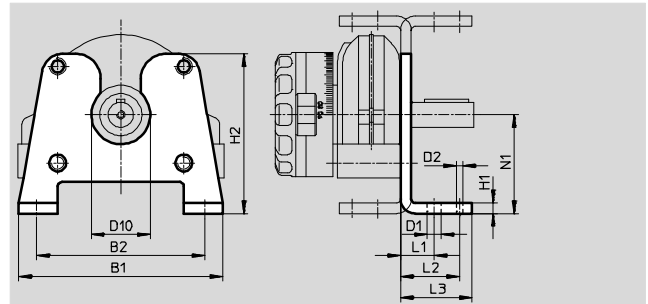

Dimensions and ordering data															
For Ø	B1	B2	D1 Ø H13	D2	D10	H1	H2	L1	L2	L3	N1	CRC <sup>1)</sup>	Weight	Part No.	Type
[mm]													[g]		
10	53.5	43	3.5	2	20	4	53	11	17	21	34	2	61	33 317	HSR-10-FW
12	64	52	3.5	2	22	4	63	11	17	21	40	2	87	30 923	HSR-12-FW
16	77	63	5.7	2	24	5	71	14	22	26.5	44	2	170	30 924	HSR-16-FW
25	97	80	6.8	3	28	5	76	16	28	34	47	2	235	30 925	HSR-25-FW
32	129	105	8.8	4	42	8	108	20	34	43	66	2	660	30 926	HSR-32-FW
40	159	130	8.8	5	52	8	134	25	42	52	81	2	1,040	30 927	HSR-40-FW

1) Corrosion resistance class 2 according to Festo standard 940 070  
Components requiring moderate corrosion resistance. Externally visible parts with primarily decorative surface requirements which are in direct contact with a surrounding industrial atmosphere or media such as cooling or lubricating agents

## Flange mounting FSR

Material:  
Aluminium

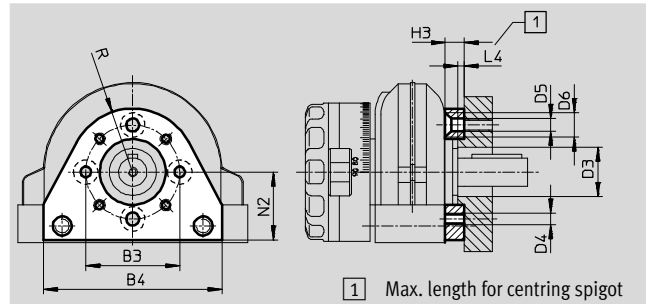
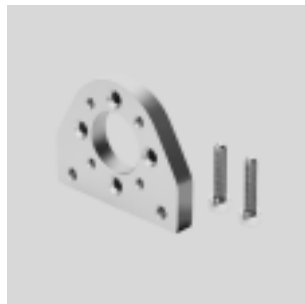

Dimensions and ordering data														
For Ø	B3	B4	D3 Ø min.	D4	D5 Ø H13	D6 Ø H13	H3	L4	N2	R	CRC <sup>1)</sup>	Weight	Part No.	Type
[mm]								max.				[g]		
10	28	46	13	M3	3.4	6.5	7	2	20	18	2	22	34 480	FSR-10
12	31	54	17	M3	3.4	6.5	7	2	22	20.5	2	32	14 658	FSR-12
16	35	62	19	M4	4.5	8.5	8	2	26.5	23.5	2	50	13 236	FSR-16
25	40	76	21	M5	5.5	10.4	8	2.5	29	27	2	70	13 237	FSR-25
32	56	100	32	M6	6.6	12.4	12	2.5	42	36	2	180	13 238	FSR-32
40	72	120	37	M8	9	16.4	14	4	52	46	2	300	14 655	FSR-40

1) Corrosion resistance class 2 according to Festo standard 940 070  
Components requiring moderate corrosion resistance. Externally visible parts with primarily decorative surface requirements which are in direct contact with a surrounding industrial atmosphere or media such as cooling or lubricating agents

# Semi-rotary drives DSR/DSRL

Accessories

## Push-on flange FWSR

The permissible tightening torque may not be exceeded when installing the push-on flange FWSR on the drive shaft.

Material:  
Wrought aluminium alloy, anodised  
Copper, PTFE and silicone free

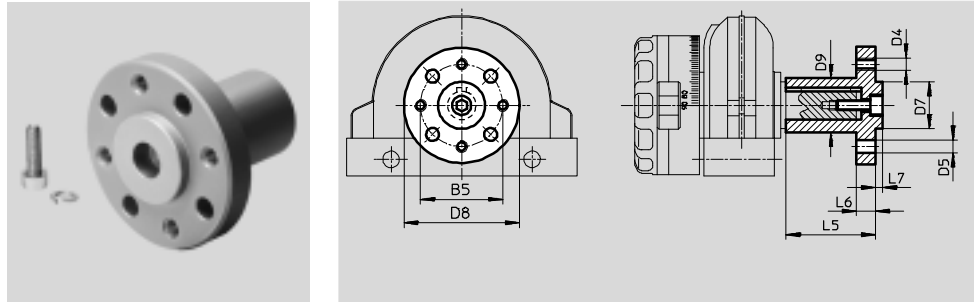

Dimensions and ordering data														
For $\varnothing$	B5	D4	D5 $\varnothing$ H13	D7 $\varnothing$ f8	D8	D9	L5	L6	L7	Tightening torque [Nm]	CRC <sup>1)</sup>	Weight [g]	Part No.	Type
[mm]														
10	21	M3	3.4	11	30	12	22	3	1.6	0.7	2	10	<b>32 798</b>	<b>FWSR-10</b>
12	25	M3	3.4	14	35	15	25	3	3	1.2	2	19	<b>14 659</b>	<b>FWSR-12</b>
16	28	M4	4.5	16	40	17	28	5	3	1.2	2	30	<b>13 239</b>	<b>FWSR-16</b>
25	35	M5	5.5	20	50	23	38	8	3	5.5	2	70	<b>13 240</b>	<b>FWSR-25</b>
32	45	M6	6.6	28	60	28	48	10	4	5.5	2	120	<b>13 241</b>	<b>FWSR-32</b>
40	54	M8	9	36	70	38	60	11	5	5.5	2	240	<b>14 656</b>	<b>FWSR-40</b>

1) Corrosion resistance class 2 according to Festo standard 940 070

Components requiring moderate corrosion resistance. Externally visible parts with primarily decorative surface requirements which are in direct contact with a surrounding industrial atmosphere or media such as cooling or lubricating agents

# Semi-rotary drives DSR/DSRL

Accessories

FESTO

## Freewheel unit FLSR

Material:

Housing: Aluminium die-cast

Sleeve, shaft: Case-hardened steel

Seal, cap: Nitrile rubber

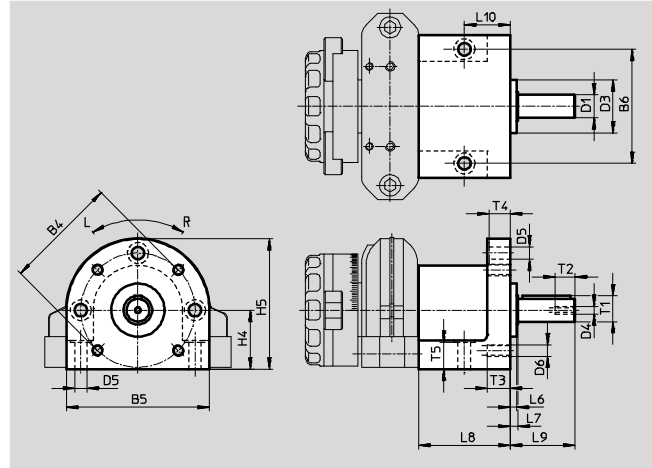

General technical data							
Piston $\varnothing$		10	12	16	25	32	40
Design	Freewheel unit as attachment						
Rotation angle	Infinitely adjustable steps (independent of rotation angle)						
Applied radial load	[N]	52	77	160	350	200	350
Applied axial load	[N]	30	50	100	200	75	120
Max. torque	[Nm]	0.7	1.3	2.7	6.6	13.3	26.7
Frequency	3 Hz ( $\frac{1}{3}$ · The load must be stopped externally!)						
Temperature range	[°C]	-10 ... +60					

## Direction of rotation

The freewheel unit blocks one of the two possible swivel directions of the DSM swivel module.

### FLSM-...-R, right-hand (clockwise) rotation

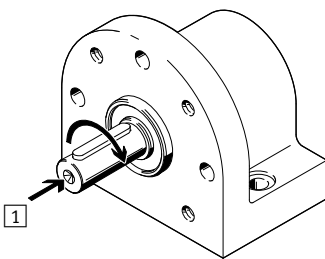

1 Viewed towards drive shaft

### FLSM-...-L, left-hand (counter-clockwise) rotation

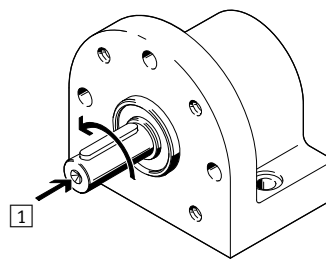

# Semi-rotary drives DSR/DSRL

Accessories

Dimensions and ordering data															
For Ø [mm]	B4	B5	B6	D1 Ø g7	D3 Ø h8	D4	D5 Ø H13	D6	H4	H5	L6	L7	L8	L9	L10
10	38	45	38.5	6	20	–	3.3	M3	20	42.5	3.5	4.2	41.5	20.2	23
12	42	49	41.5	8	25	M3	3.3	M3	24	48.5	3.5	4.5	47.3	24.5	25
16	50	60	50	10	24	M3	4.5	M4	28	58	3.5	4.4	47	27.4	23.5
25	60	75	60	12	28	M4	6.6	M6	31	68.5	3.5	4.1	48	34	24
32	83	98	83	16	42	M5	6.6	M6	44	93	7.2	8.5	60	48.5	30
40	96	114	96	20	52	M6	8.6	M8	54	111	6	8	75	58	38

For Ø [mm]	T1	T2	T3	T4	T5	Woodruff key <sup>1)</sup> to DIN 6885	CRC <sup>2)</sup>	Weight [g]	Direction of rotation	Part No.	Type
10	6.8	8	8	5	8	A2 x 2 x 12	2	165	left-hand	<b>33 298</b>	<b>FLSR-10-L</b>
									right-hand	<b>33 299</b>	<b>FLSR-10-R</b>
12	8.8	9	8	5	9	A2 x 2 x 16	2	225	left-hand	<b>30 930</b>	<b>FLSR-12-L</b>
									right-hand	<b>30 929</b>	<b>FLSR-12-R</b>
16	11.2	11	10	8	11	A3 x 3 x 18	2	340	left-hand	<b>15 281</b>	<b>FLSR-16-L</b>
									right-hand	<b>15 280</b>	<b>FLSR-16-R</b>
25	13.5	14	12	11	14	A4 x 4 x 25	2	500	left-hand	<b>13 778</b>	<b>FLSR-25-L</b>
									right-hand	<b>13 730</b>	<b>FLSR-25-R</b>
32	18	16	12	11	16	A5 x 5 x 36	2	1 140	left-hand	<b>15 688</b>	<b>FLSR-32-L</b>
									right-hand	<b>15 687</b>	<b>FLSR-32-R</b>
40	22.5	21	15	11	21	A6 x 6 x 45	2	1 800	left-hand	<b>19 037</b>	<b>FLSR-40-L</b>
									right-hand	<b>19 036</b>	<b>FLSR-40-R</b>

1) included in scope of delivery

2) Corrosion resistance class 2 according to Festo standard 940 070

Components requiring moderate corrosion resistance. Externally visible parts with primarily decorative surface requirements which are in direct contact with a surrounding industrial atmosphere or media such as cooling or lubricating agents

# Semi-rotary drives DSR/DSRL

Accessories



## Mounting kit

### WSR-10/12-K

for micro switch S-3-BE, S-3-BE-SW

Material:

Steel

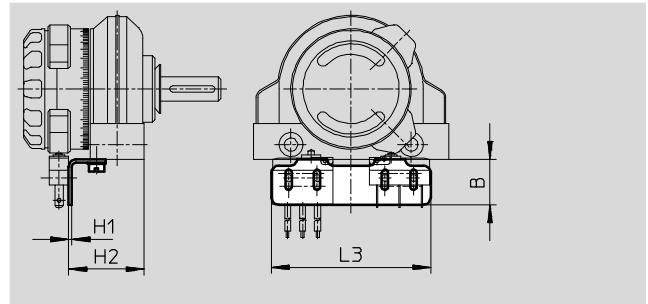

### Dimensions and ordering data

For Ø	B	H1	H2	L3	CRC <sup>1)</sup>	Weight	Part No.	Type
[mm]						[g]		
10	15	1	22.2	47	2	11	<b>33 414</b>	<b>WSR-10-K</b>
12	15	1	25.1	53	2	13	<b>15 686</b>	<b>WSR-12-K</b>

1) Corrosion resistance class 2 according to Festo standard 940 070

Components requiring moderate corrosion resistance. Externally visible parts with primarily decorative surface requirements which are in direct contact with a surrounding industrial atmosphere or media such as cooling or lubricating agents

## Mounting kit

### WSR-12 ... 40

for micro switch S-3-E, SR-3-E-SW and  
micro stem actuated valve  
S-3-PK-3-B, SO-3-PK-3-B

Material:

Steel

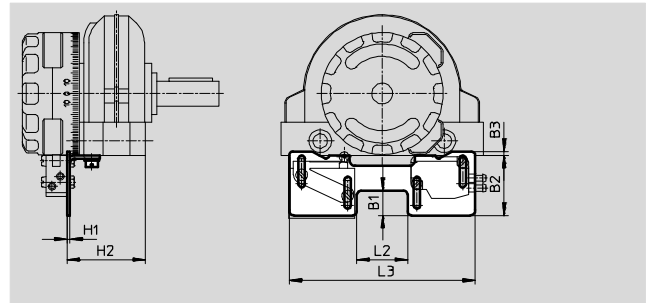
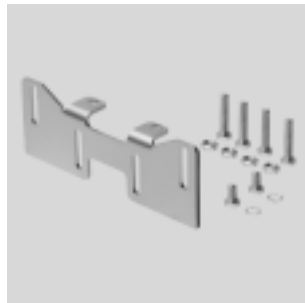

### Dimensions and ordering data

For Ø	B1	B2	B3	H1	H2	L2	L3	CRC <sup>1)</sup>	Weight	Part No.	Type
[mm]									[g]		
12	5.8	23.4	4	1.5	23	14	79	2	12	<b>15 684</b>	<b>WSR-12</b>
16	10	26.5	4.5	1.5	29.8	19	84.5	2	23	<b>14 874</b>	<b>WSR-16</b>
25	12	29	2	1.5	38	24.5	90	2	26	<b>14 796</b>	<b>WSR-25</b>
32	12	29	2	1.5	49.2	40.5	107	2	29	<b>14 960</b>	<b>WSR-32</b>
40	12	29	2	1.5	68.7	52	118.5	2	32	<b>14 961</b>	<b>WSR-40</b>

1) Corrosion resistance class 2 according to Festo standard 940 070

Components requiring moderate corrosion resistance. Externally visible parts with primarily decorative surface requirements which are in direct contact with a surrounding industrial atmosphere or media such as cooling or lubricating agents



# Semi-rotary drives DSR/DSRL

Accessories

## Mounting kit

### WSR-...-J

for proximity sensors SIEN-M8

### WSR-...-J-M5

for proximity sensors SIEN-M5

Material:

Steel

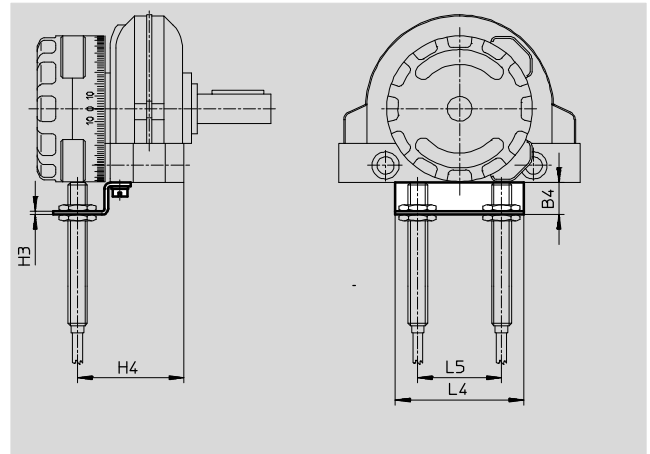

Dimensions and ordering data									
WSR-...-J									
For Ø	B4	H3	H4	L4	L5	CRC <sup>1)</sup>	Weight	Part No.	Type
[mm]							[g]		
16	13	1.5	35	52	27	2	12	14 873	WSR-16-J
25	13	1.5	43.1	52	34	2	17	14 799	WSR-25-J
32	13	1.5	54.3	64	48	2	18	14 962	WSR-32-J
40	13	1.5	76.3	80	60	2	24	14 963	WSR-40-J

WSR-...-J-M5									
For Ø	B4	H3	H4	L4	L5	CRC <sup>1)</sup>	Weight	Part No.	Type
[mm]							[g]		
10	8	1	25.4	30	20	2	6	33 413	WSR-10-J-M5
12	8	1	28.3	34	24.5	2	10	15 685	WSR-12-J-M5
16	8	1	34.9	38	27	2	78	15 931	WSR-16-J-M5
25	13	1.5	43	52	34	2	17	15 932	WSR-25-J-M5
32	13	1.5	54.3	64	48	2	25	15 933	WSR-32-J-M5
40	13	1.5	76.3	80	60	2	30	15 934	WSR-40-J-M5

1) Corrosion resistance class 2 according to Festo standard 940 070  
 Components requiring moderate corrosion resistance. Externally visible parts with primarily decorative surface requirements which are in direct contact with a surrounding industrial atmosphere or media such as cooling or lubricating agents

# - 7 - Type discontinued SR-3-E-SW Available up until 2015

## Semi-rotary drives DSR/DSRL

Accessories

FESTO

### Electrical limit switch for end-position sensing

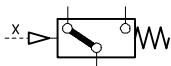

The switching point may only be exceeded by 0.5 mm in these electrical limit switches. Actuation only vertical to stem axis.

	S-3-BE	S-3-BE-SW	S-3-E	SR-3-E-SW
Connection	3 push-in connectors (2.8x0.5 mm)	3 wires (0.75 mm <sup>2</sup> )	Screw connector	3 wires 0.5 m long
Contact rating	➔ Table below			
Operating voltage	250 V AC/250 V DC			
Line current ohmic load	-	-	6 A/250 V AC 0.25 A/250 V DC	5 A/250 V AC 0.25 A/250 V DC
Line current inductive load	-	-	2 A/250 V AC 0.1 A/250 V DC	2 A/250 V AC 0.03 A/250 V DC
Utilisation category	AC 12/DC 12 (ohmic load) AC 14/DC 13 (inductive load)			
CE symbol	Yes, as per EU Directive 73/23/EEC			
Protection class to EN 60 529	IP40	IP67	IP 00	IP65
Temperature range	-20 ... +85 °C		-20 ... +80 °C	
Material	Housing, cover: black plastic			
Weight	2 g	16 g	7 g	10 g

Test symbols:

- S-3-BE: VDE-ÜG, UL, CSA, SEMKO
- S-3-BE-SW: VDE, SEV, SEMKO, BEAB
- S-3-E: VDE, ÖVE, SEMKO, SEV, UL, CSA

Contact configuration:

Changeover switch

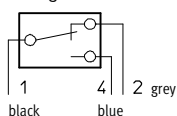

NC contact

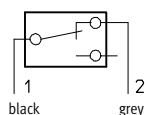

NO contact

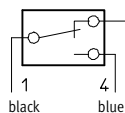

S-3-BE, S-3-BE-SW				
AC voltage				
Voltage [V] ~	Resistance load [A]	Inductive load [A]		
12	6	6		
24	3	2		
60	1	0.5		
110	0.5	0.2		
220	0.25	0.1		
S-3-E	DC	AC	DC	AC
12	6	-	6	-
24	6	-	6	-
60	1	-	0.5	-
110	0.5	-	0.2	-
220	0.25	-	0.1	-
250	-	6	-	2
SR-3-E-SW	DC	AC	DC	AC
15	3	-	5	-
30	3	-	5	-
50	1	-	1	-
75	0.25	-	0.75	-
125	0.03	5	0.5	5
250	0.03	5	0.25	5

### Pneumatic limit valve for end-position sensing

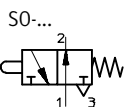
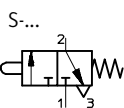

The switching point is pressure-dependent and deviates up to 0.8 mm in the pressure range from 0 ... 8 bar. The switching point may only be exceeded by 0.5 mm. The valve must not be used as a fixed stop and should only be operated vertically to the stem.

S-3-PK-3-B/SO-3-PK-3-B	
Connection	Barbed fitting for 3 mm plastic tubing
Nominal size	1.8 mm
Standard nominal flow rate (1 > 2)	60 l/min
Pressure range	-0.95 ... +8 bar
Actuating force at 6 bar	6 N
Temperature range	-10 ... +60 °C
Materials	Plastic, brass
Weight	7 g

 Type discontinued SR-3-E-SW  
Available up until 2015

FESTO

## Semi-rotary drives DSR/DSRL

Accessories

### Electrical limit switch for end-position sensing

Micro switch  
S-3-BE

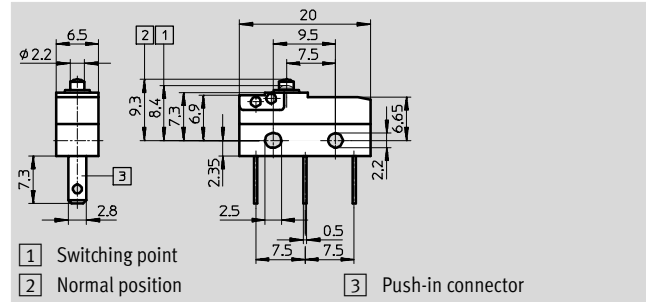

Micro switch with cable (splash-proof)  
S-3-BE-SW

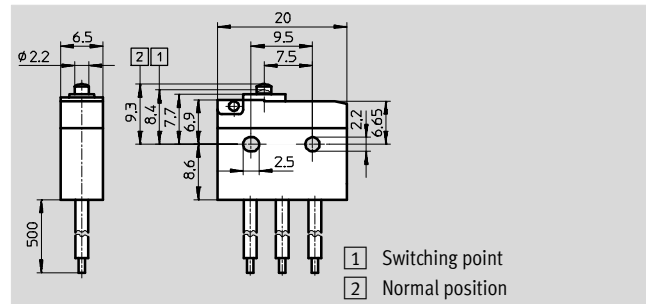

Micro switch  
S-3-E

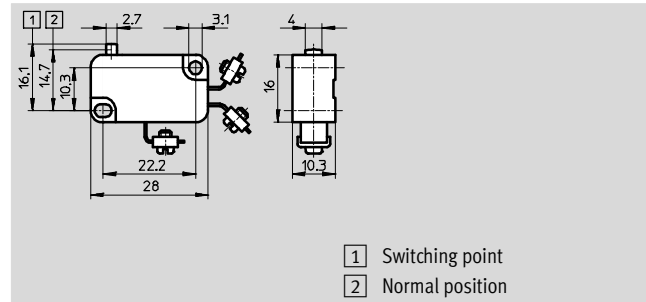

Micro switch with roller lever  
(splash-proof)  
SR-3-E-SW

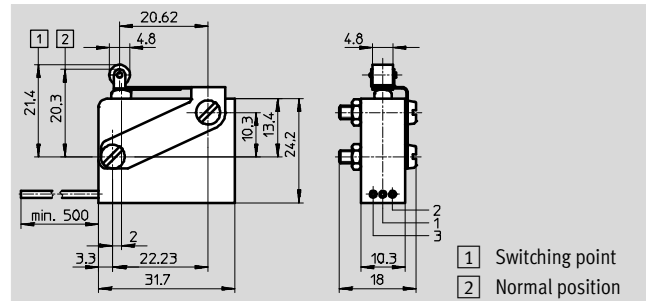

Ordering data				
For Ø	Electrical limit switches, splash-proof	Design	Part No.	Type
[mm]				
10 ... 12			30 648	S-3-BE
		With cable	30 649	S-3-BE-SW
16 ... 40		With roller lever	7 347	S-3-E
			14 797	SR-3-E-SW

# Semi-rotary drives DSR/DSRL

Accessories



## Pneumatic limit valve for end-position sensing

Micro stem actuated valve

S-3-PK-3-B

SO-3-PK-3-B

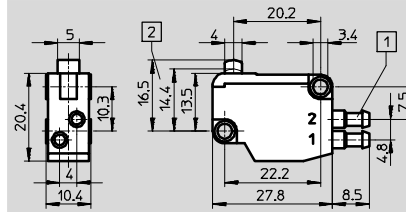

- 1 Barbed fittings for 3 mm plastic tubing
- 2 Switching point min.
- 1 (P) = supply port
- 2 (A) = working or outlet line
- 3 (R) = exhaust

Ordering data				
For Ø [mm]	Pneumatic limit switch	Design	Part No.	Type
16 ... 40		Normally closed	7 843	S-3-PK-3-B
		Normally open	10 403	SO-3-PK-3-B

Ordering data – Proximity sensors, inductive				Technical data → Internet: sien	
	For Ø	Remarks	Connection	Part No.	Type
	10 ... 40	For mounting kit WSR-...-J-M5	Cable	150 370	SIEN-M5B-PS-K-L
			Plug	150 371	SIEN-M5B-PS-S-L
	16 ... 40	For mounting kit WRM-...-J	Cable	150 386	SIEN-M8B-PS-K-L
			Plug	150 387	SIEN-M8B-PS-S-L

Ordering data – Connecting cables				Technical data → Internet: nebu	
	Electrical connection, left	Electrical connection, right	Cable length [m]	Part No.	Type
	Straight socket, M8x1, 3-pin	Cable, open end, 3-wire	2.5	541 333	NEBU-M8G3-K-2.5-LE3
			5	541 334	NEBU-M8G3-K-5-LE3
	Angled socket, M8x1, 3-pin	Cable, open end, 3-wire	2.5	541 338	NEBU-M8W3-K-2.5-LE3
			5	541 341	NEBU-M8W3-K-5-LE3

Ordering data – One-way flow control valves				Technical data → Internet: grla		
	Connection		Material	Part No.	Type	
	Thread	For tubing OD				
	M3	3	Metal design	175 041	GRLA-M3-QS-3	
		M5		3	193 137	GRLA-M5-QS-3-D
	4			193 138	GRLA-M5-QS-4-D	
	6			193 139	GRLA-M5-QS-6-D	
	G1/8			3	193 142	GRLA-1/8-QS-3-D
				4	193 143	GRLA-1/8-QS-4-D
				6	193 144	GRLA-1/8-QS-6-D
		8		193 145	GRLA-1/8-QS-8-D	
	G1/4	6		193 146	GRLA-1/4-QS-6-D	
		8		193 147	GRLA-1/4-QS-8-D	
		10		193 148	GRLA-1/4-QS-10-D	