

Twin-piston semi-rotary drives DRRD

FESTO



Twin-piston semi-rotary drives DRRD

Key features

At a glance

- Rack and pinion principle
- Very high accuracy in the end positions
- Very high bearing load capacity
- Very good axial run-out at the flanged shaft
- High mass moments of inertia
- Low backlash and dynamic
- Splash-proof design to IP65 based on EN 60529
- Defined interfaces
- Supply port at one end
- Choice of mounting options
- Ideal for use in handling applications

Wide choice of variants

Flanged shaft



- Size 8 ... 63
- Torque: 0.2 ... 112 Nm
- Swivel angle: 0 ... 180°

End-position locking



- Size 16 ... 63
- Mechanical lock in the end positions to prevent unwanted movement in unpressurised condition

Position sensing



- Size 8 ... 12:
 - C-slot for proximity sensor SMT/SME-10
- Size 16 ... 63:
 - T-slot for proximity sensor SMT/SME-8

External position sensing (sensor mounting)



- Size 16 ... 63
- Position sensing possible directly at the flanged shaft
- Inductive proximity sensors SIES can be used in combination with external position sensing

Cushioning



- Size 12 ... 63
- Choice of four cushioning types:
 - Elastic cushioning with metal end position (P)
 - Shock absorber (Y9)
 - Shock absorber, hard (Y10)
 - Shock absorber, external (Y12)

External cushioning



- Size 12 ... 63
- The full torque can be realised in the end positions in combination with external cushioning

Energy throughfeed



- Size 16 ... 63
- Electrical signals or compressed air can be transferred through the hollow shaft using the energy throughfeed. This enables fast and easy supply of the parts connected to the flange (e.g. gripper)

Intermediate position



- Size 16 ... 50
- The semi-rotary drive can additionally be positioned at 90° using the intermediate-position module
- The intermediate position can be approached from both directions
- The cushioning for the intermediate position corresponds to the cushioning for the basic drive. Except in the case of cushioning Y12: when shock absorbers Y9 are used

Twin-piston semi-rotary drives DRRD

System example

Mounting options

Via through-holes

Via thread in the housing profile

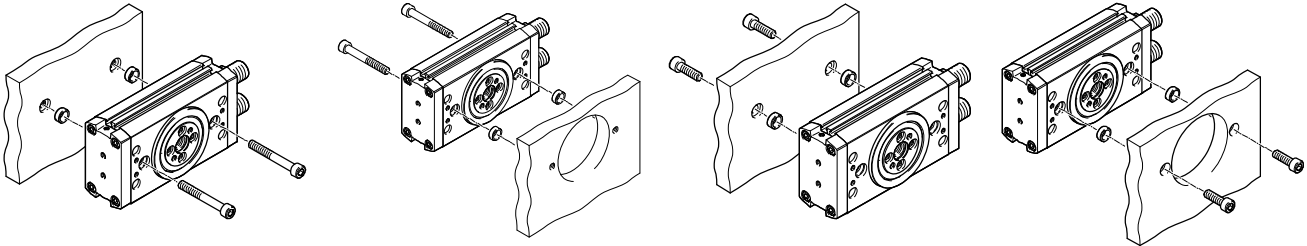

System product for handling and assembly technology

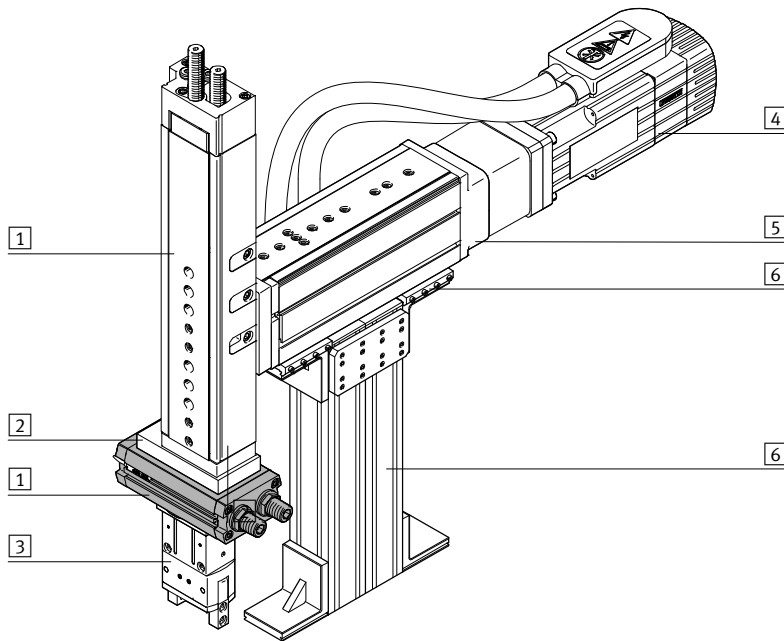

System components and accessories

	Brief description	→ Page/Internet
1	Drives	drive
2	Adapters	adapter kit
3	Grippers	gripper
4	Motors	motor
5	Axes	axis
6	Basic components	basic component
-	Installation components	installation component

Twin-piston semi-rotary drives DRRD

Product range overview

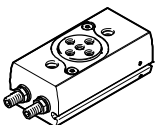
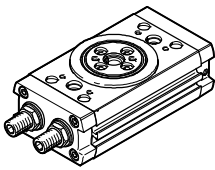
Function	Version	Size	Swivel angle	Energy throughput					
				[°]	P2	P2E2	P4	P4E6	P8
Double-acting	DRRD-8 ... 12								
		8	Max. 200	-	-	-	-	-	-
		10	Max. 200	-	-	-	-	-	-
		12	Max. 200	-	-	-	-	-	-
	DRRD-16 ... 63								
		16	Max. 200	■	■	-	-	-	-
		20	Max. 200	■	■	-	-	-	-
		25	Max. 200	-	-	■	■	-	-
		32	Max. 200	-	-	■	■	-	-
		35	Max. 200	-	-	■	■	-	-
		40	Max. 200	-	-	-	-	■	■
50		Max. 200	-	-	-	-	■	■	
63		Max. 200	-	-	-	-	■	■	

Twin-piston semi-rotary drives DRRD

Product range overview

Function	Size	Cushioning				Position sensing	EU certification	Intermediate position	End-position locking	Sensor mounting, external	Splash-proof design	→ Page/ Internet	
		P	Y9	Y10	Y12								A
Double-acting	DRRD-8 ... 12											8	
	8	■	-	-	-	■	-	-	-	-	-		-
	10	■	-	-	-	■	-	-	-	-	-		
	12	■	■	-	■	■	-	-	-	-	-		
	DRRD-16 ... 63											20	
	16	■	■	-	■	■	■	■	■	■	■		
	20	■	■	-	■	■	■	■	■	■	■		
	25	■	■	■	■	■	■	■	■	■	■		
	32	■	■	-	■	■	■	■	■	■	■		
	35	■	■	■	■	■	■	■	■	■	■		
	40	■	■	■	■	■	■	■	■	■	■		
	50	-	■	■	■	■	■	■	■	■	■		
	63	-	■	■	■	■	■	-	■	■	■		

Twin-piston semi-rotary drives DRRD-8 ... 12

Peripherals overview

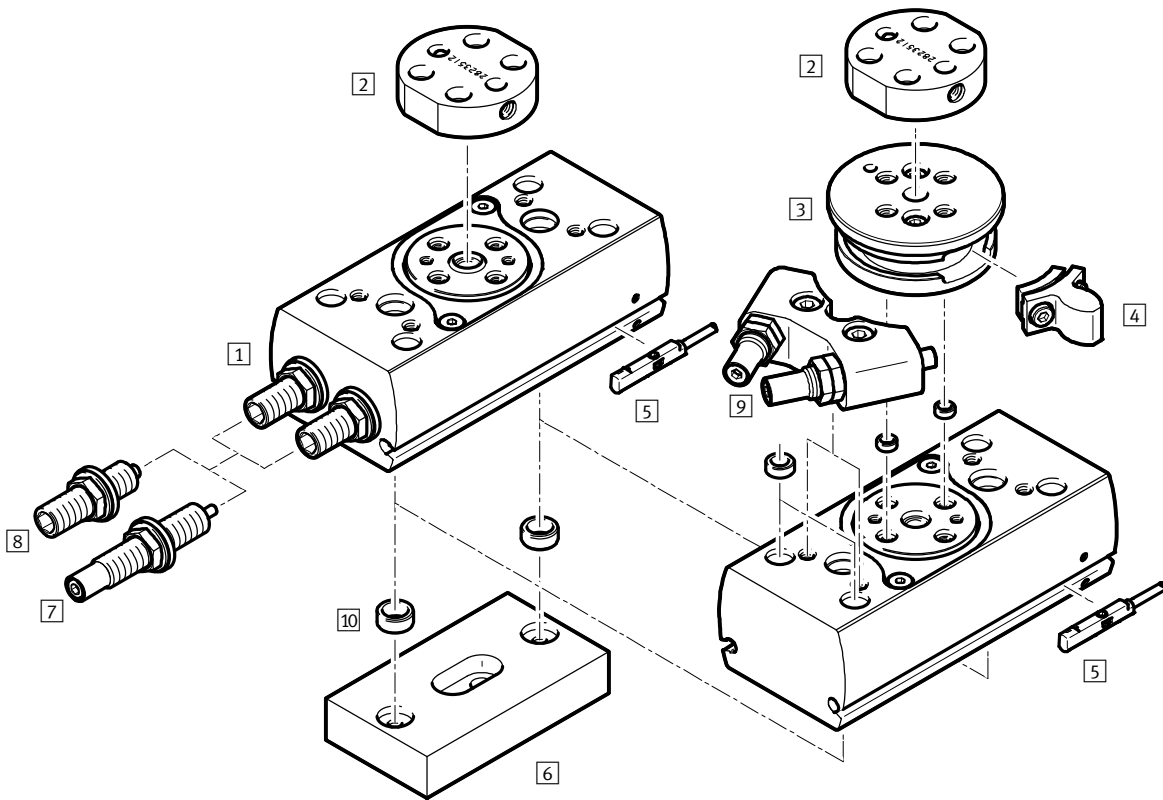

Twin-piston semi-rotary drives DRRD-8 ... 12

Peripherals overview

Variants, mounting components and accessories						
	Description	Size			→ Page/ Internet	
		8	10	12		
[1]	Semi-rotary drive DRRD	Double-acting	■	■	■	8
[2]	Adapter kit DHAA	<ul style="list-style-type: none"> Connecting plate between semi-rotary drive and gripper Included in the scope of delivery: 2 centring sleeves and screws 	■	■	■	gripper
[3]	Flange assembly	<ul style="list-style-type: none"> Required to mount component [4] 	-	-	■	18
[4]	Stop element	<ul style="list-style-type: none"> Serves as an end stop in combination with external shock absorbers (Y12) Two stop elements are included in the scope of delivery of external shock absorbers (Y12) 	-	-	■	18
[5]	Proximity sensor SMT/SME-10	For sensing the piston position	■	■	■	57
[6]	Adapter kit DHAA	Connecting plate between semi-rotary drive and drive	■	■	■	62
[7]	Shock absorber Y9	Linear shock absorber, self-adjusting at both ends	-	-	■	19
[8]	Shock absorber P	Elastic cushioning with metal end position, both ends	■	■	■	19
[9]	Shock absorber, external Y12	<ul style="list-style-type: none"> Linear shock absorber, self-adjusting at both ends, external Included in the scope of delivery: [3], 2x [4], [9] 	-	-	■	19
[10]	Centring sleeve ZBH	For centring attachments (two centring sleeves for mounting the semi-rotary drive included in the scope of delivery)	■	■	■	56

Twin-piston semi-rotary drives DRRD-8 ... 12

Type codes

		DRRD	-		-	180	-	FH	-			-	
Product type													
Double-acting													
DRRD	Semi-rotary drive												
Size													
Nominal swivel angle													
180	180°												
Output shaft													
FH	Flanged shaft, hollow												
Cushioning													
P	Elastic cushioning at both ends												
Y9	Linear shock absorber, self-adjusting at both ends, internal												
Y12	Linear shock absorber, self-adjusting at both ends, external												
Position sensing													
A	Via proximity sensor												
Operating instructions													
-	With operating instructions												
DN	Without operating instructions												

Twin-piston semi-rotary drives DRRD-8 ... 12

Technical data

Function

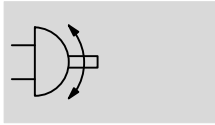

 www.festo.com



 Diameter
8 ... 12 mm

 Torque
0.2 ... 0.8 Nm

General technical data			
Size	8	10	12
Design	Rack and pinion		
Mode of operation	Double-acting		
Pneumatic connection	M3	M3	M5
Type of mounting	With through-hole Via female thread		
Swivel angle [°]	180 (→ 11)		
Cushioning with fixed stop			
DRRD-...-P	Elastic cushioning at both ends		
DRRD-...-Y9	-		Linear shock absorber, self-adjusting at both ends
DRRD-...-Y12	-		Linear shock absorber, self-adjusting at both ends, external
Repetition accuracy [°]	≤ 0.03		
Axial run-out ¹⁾ [mm]	≤ 0.02		
Max. axial load (static)			
Tension [N]	260	260	330
Pressure [N]	700	1100	1400
Assembly position	Any		

1) Axial run-out in new condition

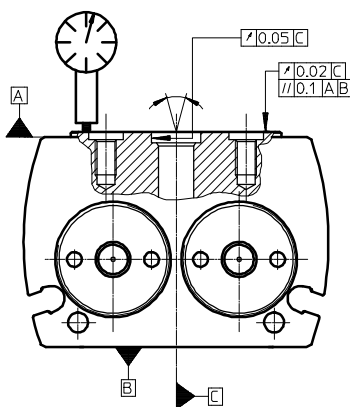

Twin-piston semi-rotary drives DRRD-8 ... 12

Technical data

Operating and environmental conditions			
Operating medium		Compressed air to ISO 8573-1:2010 [7:4:4]	
Note on operating/pilot medium		Lubricated operation possible (in which case lubricated operation will always be required)	
Operating pressure			
DRRD-...-P	[bar]	3 ... 8	
DRRD-...-Y9/-Y12	[bar]	2 ... 10	
Ambient temperature		[°C]	-10 ... +60
Storage temperature		[°C]	-20 ... +60

Weight [g]				
Size		8	10	12
DRRD-...-P		155	245	380
DRRD-...-Y9		-	-	385
DRRD-...-Y12		-	-	500

Forces and torques				
Size		8	10	12
Theoretical torque at 6 bar	[Nm]	0.2	0.4	0.8
Max. permissible mass moment of inertia				
DRRD-...-P	[kgcm ²]	15	20	80
DRRD-...-Y9	[kgcm ²]	-	-	300
DRRD-...-Y12	[kgcm ²]	-	-	300

 **Note**

If, in the end positions, a torque which exceeds 50% of the theoretical torque acts against the direction of rotation, no exact end position is guaranteed.

This can be avoided by using external shock absorbers (Y12) or a semi-rotary drive with double the torque.

Materials

Sectional view

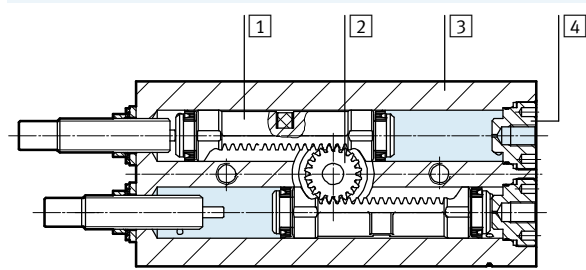

Semi-rotary drive		
1	Piston	Copper base alloy
2	Flanged shaft	High-alloy stainless steel
3	Housing	Wrought aluminium alloy, smooth-anodised
4	Port plug	High-alloy stainless steel
	Seals	NBR
	Piston seal	TPE-U(PU)
	Note on materials	RoHS-compliant
		Contains PWIS (paint-wetting impairment substances)

Twin-piston semi-rotary drives DRRD-8 ... 12

Technical data

Swivel angle

Fundamentally, the following applies:

Swivel angle $\alpha \geq$ cushioning angle β

Swivel angle $\alpha = 180^\circ + \Delta\alpha_{\text{clockwise}} + \Delta\alpha_{\text{anti-clockwise}}$

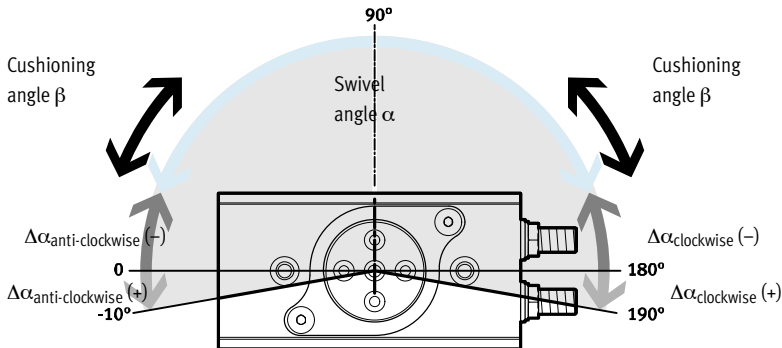

Size		8	10	12
Swivel angle α	[°]	180		
Min. swivel angle $\alpha^{1)}$				
DRRD-...-P	[°]	38	37	32
DRRD-...-Y9	[°]	-	-	48
DRRD-...-Y12	[°]	-	-	20
Max. swivel angle α				
DRRD-...	[°]	200		
DRRD-...-Y12	[°]	-	-	192
Swivel angle adjustment α per side (infinitely adjustable)				
DRRD-...-P	[°]	-100 ... +10		
DRRD-...-Y9	[°]	≥ -100 ... +10		
DRRD-...-Y12	[°]	-	-	-92 ... +6
Cushioning angle β				
DRRD-...-P	[°]	38	37	32
DRRD-...-Y9	[°]	-	-	48
DRRD-...-Y12	[°]	-	-	10

1) It is possible to set smaller swivel angles. However, this reduces the cushioning energy.

Swivel angle adjustment

Clockwise direction of rotation:

- Swivel angle decreases

Anti-clockwise direction of rotation:

- Swivel angle increases

The swivel angle is adjusted via the cushioning components using an Allen key. Any reduction in the swivel angle should preferably be evenly split between the two end positions.

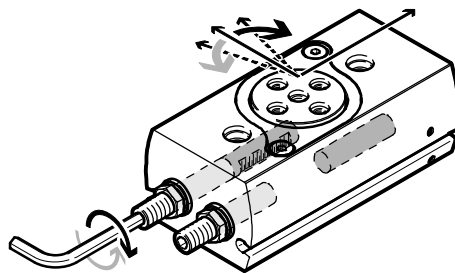

Twin-piston semi-rotary drives DRRD-8 ... 12

Technical data

Max. permissible mass moment of inertia J at the flanged shaft as a function of swivel time s
(at room temperature and an operating pressure of 6 bar)

With cushioning P

Size 8

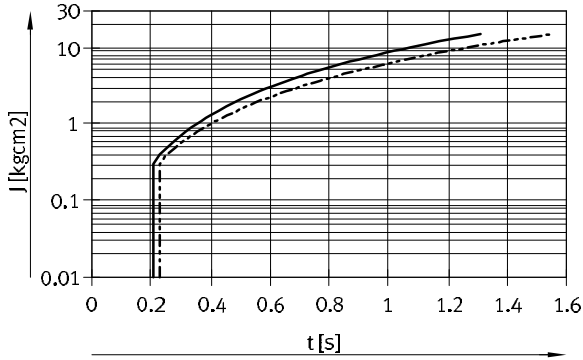

— DRRD-8-...P (90°) Ranges → 0 ... 15 kgcm^2
 - - - DRRD-8-...P (180°) Ranges → 0 ... 15 kgcm^2

Size 10

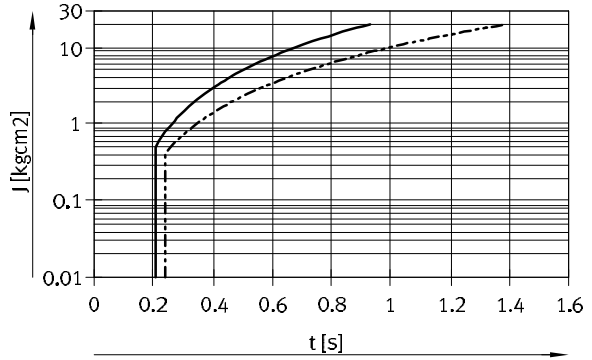

— DRRD-10-...P (90°) Ranges → 0 ... 20 kgcm^2
 - - - DRRD-10-...P (180°) Ranges → 0 ... 20 kgcm^2

Size 12

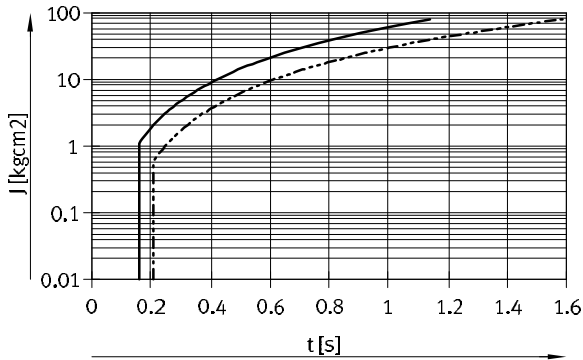

— DRRD-12-...P (90°) Ranges → 0 ... 80 kgcm^2
 - - - DRRD-12-...P (180°) Ranges → 0 ... 80 kgcm^2

Twin-piston semi-rotary drives DRRD-8 ... 12

Technical data

Max. permissible mass moment of inertia J at the flanged shaft as a function of swivel time s
(at room temperature and an operating pressure of 6 bar)

With cushioning Y9

Size 12

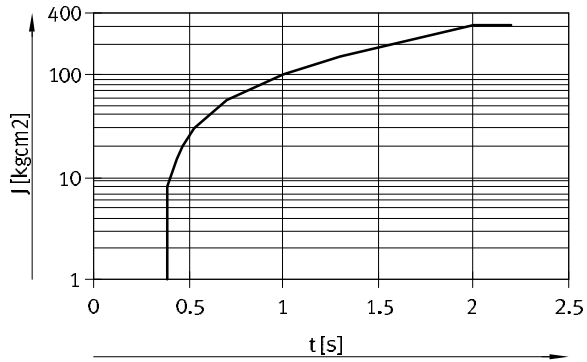

— DRRD-12-180-...-Y9 (180°) Ranges → 1 ... 300 kgcm²

With cushioning Y12

Size 12

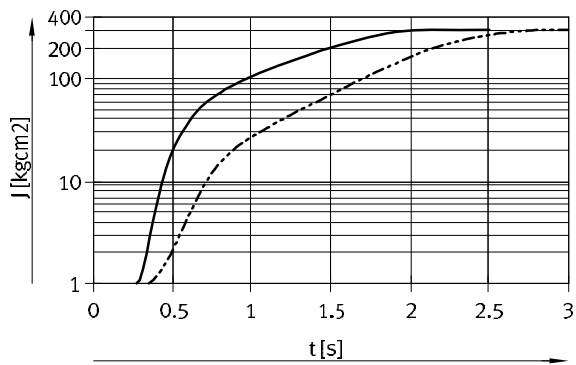

— DRRD-12-...-Y12 (90°) Ranges → 1 ... 300 kgcm²
 - - - DRRD-12-...-Y12 (180°) Ranges → 1 ... 300 kgcm²

Twin-piston semi-rotary drives DRRD-8 ... 12

Technical data

Max. dynamic load capacity at the flanged shaft

The zero point for the dimension Z is always the flange surface of the basic drive, regardless of the attachments (flange assembly).

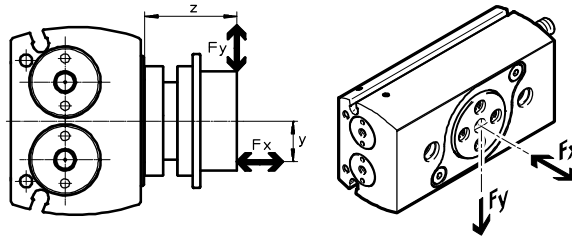

The following equation applies to combined loads (axial and radial):

$$\frac{F_{y(z)}}{F_{y, \max. (z)}} + \frac{F_{z(v)}}{F_{z, \max. (v)}} \leq 1$$

Max. dynamic radial force F_y as a function of distance z

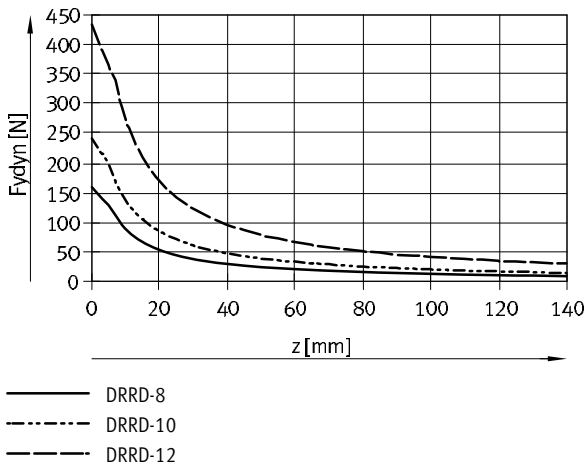

Max. dynamic axial force F_x as a function of distance y

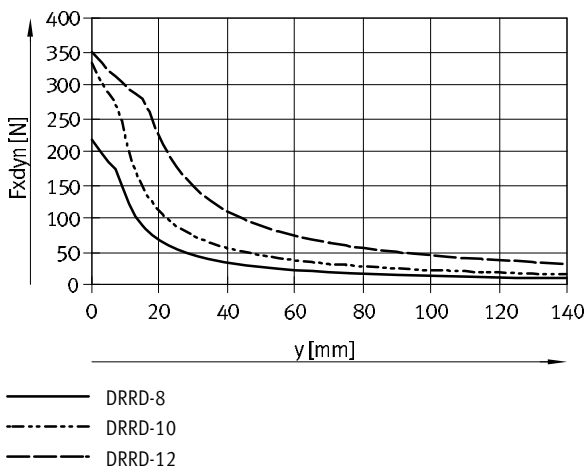

Twin-piston semi-rotary drives DRRD-8 ... 12

Technical data

Max. static load capacity at the flanged shaft

The zero point for the dimension Z is always the flange surface of the basic drive, regardless of the attachments (flange assembly).

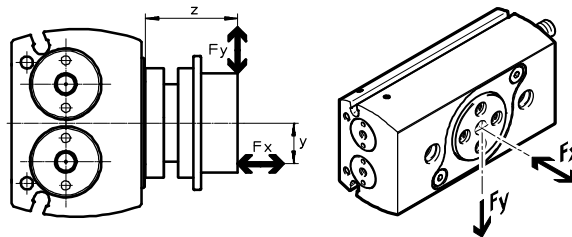

The following equation applies to combined loads (axial and radial):

$$\frac{F_{y(z)}}{F_{y, \max. (z)}} + \frac{F_{z(v)}}{F_{z, \max. (v)}} \leq 1$$

Max. static radial force F_y as a function of distance z

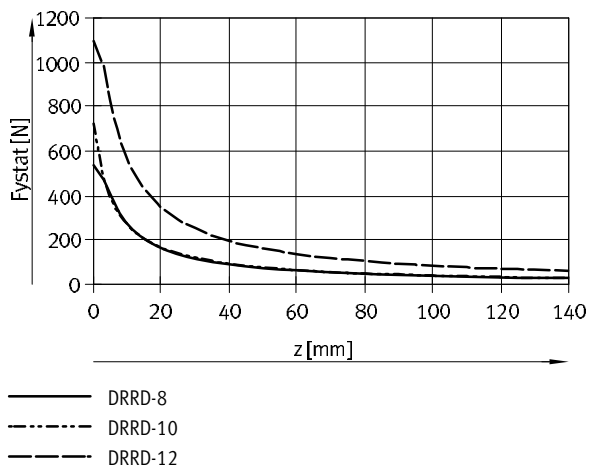

Max. static axial force F_x as a function of distance y

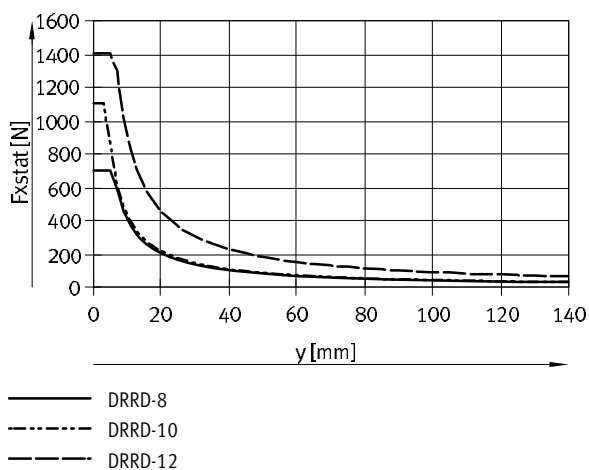

Twin-piston semi-rotary drives DRRD-8 ... 12

Technical data

Dimensions

Download CAD data → www.festo.com

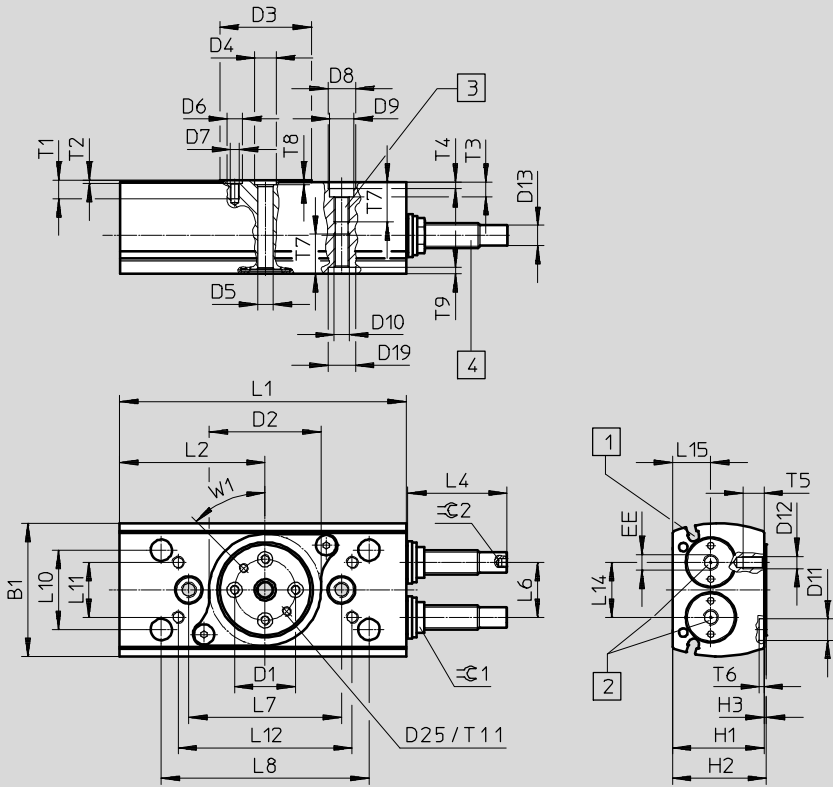

DRRD-8/10

DRRD-...-P

- 1 Sensor slots for proximity sensor
- 2 Supply ports
- 3 Mounting threads
- 4 Shock absorbers (DRRD-...-Y9)
- 5 Cushioning components (DRRD-...-P)

Twin-piston semi-rotary drives DRRD-8 ... 12

Technical data

Size	B1 ±0.25	D1 ∅ ±0.025	D2 ∅ +0.1	D3 ∅	D4 ∅ H7	D5 ∅	D6 ∅ H7	D7	D8 ∅ H7	D9 ∅	D10
8	31.5	12	26	20.4	5	3	5	M3	7	6	M4
10	38	15	32	24	5	3	5	M3	7	6	M4
12	43.5	20	37	30	7	5	5	M3	9	8	M5

Size	D11 ∅ H7	D12	D13	D19 ∅ H7	D25	H1 +0.4	H2	H3	L1 ±0.1	L2 +0.1	L6
8	–	–	M6x0.5	7	–	24.5	25.3	0.8	65.6	32.2	13 _{-0.1}
10	–	–	M6x0.5	7	–	27.5	28.3	0.8	74	38.3	15.2 _{-0.1}
12	7	M4	M8x1	9	M3	30	30.8	0.8	93.9	47.7	18 ^{+0.1}

Size	L7 ±0.02	L8 ±0.2	L10 ±0.02	L11 ±0.15	L12 ±0.2	L14	L15 –0.1	T1	T2 +0.1	T3	T4 +0.4/–0.1
8	36	–	–	–	–	13	11.1	4.8	1.2	3.4	1.5
10	44	–	–	–	–	15.2	11.1	6.2	1.2	3.4	1.5
12	50	68	26	18	57	18	12.5	5.4	1.2	4.7	2.1

Size	T5	T6 +0.4/–0.1	T7	T8 +0.1	T9 +0.1	T11	EE	W1	≈C 1	≈C 2	≈C 3
8	–	–	10.5	1.2	1.6	–	M3	45°	10	–	3
10	–	–	10	1.2	1.6	–	M3	45°	10	–	3
12	7	1.6	13	1.6	2.1	5.5	M5	45°	10	2.5	5

Size	Dimension with 180° swivel angle		Swivel angle adjustment range		
	L4	L5	L4 min./max.	L5 min./max.	1 mm = ...°
8	–	11.1	–	–6.1/+0.8	16.4
10	–	12.6	–	–7.6/+1.2	13.64
12	28	17	–1.9/+1.9	–11/+1.8	9.6

Twin-piston semi-rotary drives DRRD-8 ... 12

Technical data

Dimensions – Variants

Download CAD data → www.festo.com

Y12 – With external shock absorber

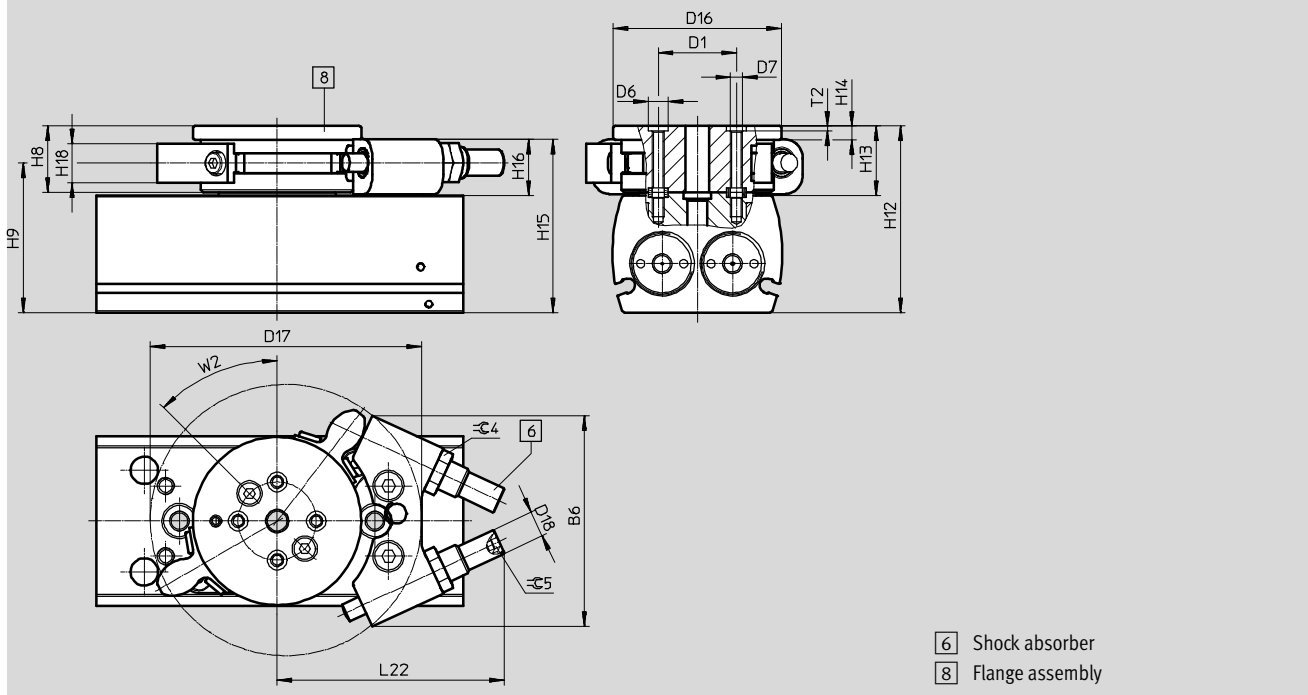

Size	B6	D1	D6	D7	D16	D17	D18	H8	H9	H12
	±0.2	∅ ±0.025	∅ H7		∅			±0.1		
12	54	20	5	M3	43	69.4	M8x1	17	38.3	47.8

Size	H13	H14	H15	H16	H18	L22	T2	W2	∅ 4	∅ 5
						max.	+0.1			
12	17.8	3.5	44	14	10	58.2	1.2	45°	10	2.5

Twin-piston semi-rotary drives DRRD-8 ... 12

Ordering data

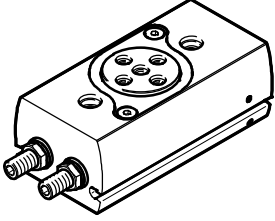
Ordering data – Stock items				
DRRD	Size	Swivel angle [°]	Part No.	Type
	P – Elastic cushioning rings/pads at both ends			
	8	180	2223060	DRRD-8-180-FH-PA
	10		2350968	DRRD-10-180-FH-PA
	12		2282067	DRRD-12-180-FH-PA
	Y9 – Linear shock absorber, self-adjusting at both ends			
	12	180	2399248	DRRD-12-180-FH-Y9A

Ordering table – Modular products				
Size	12	Condi-tions	Code	Entry code
M Module no.	574398			
Function	Semi-rotary drive		DRRD	DRRD
Size	12		-12	-12
Nominal swivel angle	180°		-180	-180
Output shaft	Flanged shaft, hollow		-FH	-FH
Cushioning	Elastic cushioning rings/pads at both ends		-P	
	Linear shock absorber, self-adjusting at both ends		-Y9	
	Linear shock absorber, self-adjusting at both ends, external		-Y12	
Position sensing	For proximity sensor		A	A
O Operating instructions	With operating instructions		-DN	
	Without operating instructions			

Transfer order code

DRRD - **12** - **180** - **FH** - **A** -

Twin-piston semi-rotary drives DRRD-16 ... 63

Peripherals overview

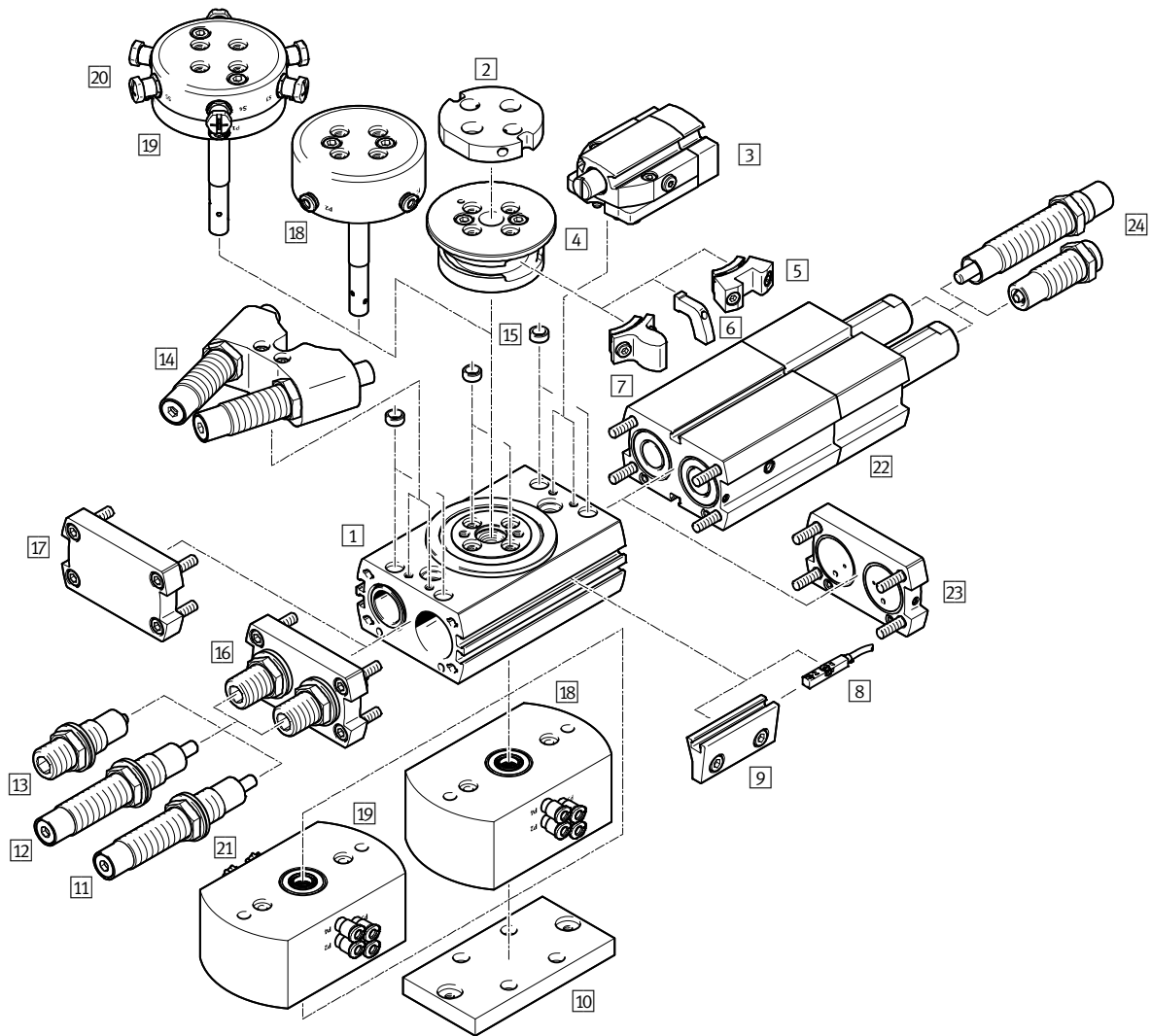

Variants, mounting components and accessories		Description	Size							→ Page/ Internet	
			16	20	25	32	35	40	50		63
[1]	Semi-rotary drive DRRD	Double-acting	■	■	■	■	■	■	■	■	22
[2]	Adapter kit DHAA	<ul style="list-style-type: none"> Connecting plate between semi-rotary drive and gripper Included in the scope of delivery: 2 centring sleeves and screws 	■	■	■	■	■	■	■	-	gripper
[3]	End-position locking E1 (clamping unit DADL-...-EL as an accessory)	<ul style="list-style-type: none"> Mechanical lock in the end positions to prevent unwanted movement in unpressurised condition Included in the scope of delivery: [3], [4], 2x [5] 	■	■	■	■	■	■	■	■	54
[4]	Flange assembly	<ul style="list-style-type: none"> Required to mount components [5], [6] and [7] 	■	■	■	■	■	■	■	■	54
[5]	Clamping component (type: DADL-EC)	<ul style="list-style-type: none"> Secures the semi-rotary drive DRRD when cylinder [3] is advanced Two clamping components are included in the scope of delivery of the end-position lock (E1) 	■	■	■	■	■	■	■	■	56

Twin-piston semi-rotary drives DRRD-16 ... 63

Peripherals overview

Variants, mounting components and accessories		Size								→ Page/ Internet
	Description	16	20	25	32	35	40	50	63	
6	Switch lug DASI-Q11-...-SL	<ul style="list-style-type: none"> For sensing the piston position using e.g. inductive proximity sensors SIES-8M → 58, in combination with sensor bracket 9 Two switch lugs are included in the scope of delivery of the sensor mounting kit (R) 								56
7	Stop element	<ul style="list-style-type: none"> Serves as an end stop in combination with external shock absorbers (Y12) Two stop elements are included in the scope of delivery of external shock absorbers (Y12) 								53
8	Proximity sensor SMT/SME-8	For sensing the piston position								57
	Positioning transmitter SMAT-8M	Analogue positional feedback possible from output 0 ... 10 V								60
9	Sensor mounting R (sensing kit DASI-...-KT as an accessory)	<ul style="list-style-type: none"> For sensing the piston position using e.g. inductive proximity sensors SIES-8M → 58 Included in the scope of delivery: 4, 2x 6, 2x 9 								55
10	Adapter kit DHAA	Connecting plate between semi-rotary drive and drive								– adapter kit
11	Shock absorbers Y9	Linear shock absorber, self-adjusting at both ends								53
12	Shock absorber, hard Y10	Linear shock absorber, self-adjusting at both ends, hard								53
13	Shock absorbers P	Elastic cushioning with metal end position, both ends								53
14	Shock absorber, external Y12	<ul style="list-style-type: none"> Linear shock absorber, self-adjusting at both ends, external Included in the scope of delivery: 4, 2x 7, 14 								53
15	Centring sleeve ZBH	For centring attachments (two centring sleeves for mounting the semi-rotary drive included in the scope of delivery)								56
16	End cap	In combination with elastic cushioning P or shock absorber Y9, Y10								–
17	End cap	In combination with external shock absorber Y12								–
18	Pneumatic energy throughfeed	Enables the quick and easy pneumatic supply of parts connected to the flange (e.g. gripper)								36
19	Pneumatic/electrical energy throughfeed	Enables the quick and easy pneumatic/electrical supply of parts connected to the flange (e.g. gripper)								36
20	Connecting cable NEBU	From the energy throughfeed to the proximity sensor								59
21	Connecting cable NEBU	From the energy throughfeed to the control								59
22	Intermediate position	Possible at 90°								– 39
23	Connection cap	For the supply ports								–
24	Shock absorber	The cushioning for the intermediate position corresponds to the cushioning for the basic drive. Except in the case of Y12: when shock absorbers Y9 are used								56
–	One-way flow control valves GRLA	To set the swivel speed								61

Twin-piston semi-rotary drives DRRD-16 ... 63

Type codes

		DRRD	-		-	180	-	FH		-		
Product type												
Double-acting												
DRRD	Semi-rotary drive											
Size												
Nominal swivel angle												
180	180°											
Output shaft												
FH	Flanged shaft, hollow											
Energy throughfeed												
-	None											
P2	Pneumatic, 2 channels											
P2E2	Pneumatic, 2 channels; electric, 2 signals											
P4	Pneumatic, 4 channels											
P4E6	Pneumatic, 4 channels; electric, 6 signals											
P8	Pneumatic, 8 channels											
P8E8	Pneumatic, 8 channels; electric, 8 signals											
Cushioning												
P	Elastic cushioning at both ends											
Y9	Linear shock absorber, self-adjusting at both ends, internal											
Y10	Linear shock absorber, self-adjusting at both ends, hard, internal											
Y12	Linear shock absorber, self-adjusting at both ends, external											
Position sensing												
A	For proximity sensor											

Twin-piston semi-rotary drives DRRD-16 ... 63

Type codes

		-		-		-		-		-		-	
EU certification													
-	None												
EX4	II 2GD												
Intermediate position													
-	Without												
PS1	1 intermediate position												
End-position locking													
-	Without												
E1	At both ends												
Sensor mounting, external													
-	Without												
R	Mounting rail for proximity sensor												
Version													
-	Standard												
SG	Splash-proof design												
Operating instructions													
-	With operating instructions												
DN	Without operating instructions												

Twin-piston semi-rotary drives DRRD-16 ... 63

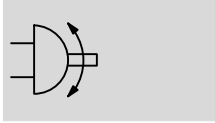

Technical data

Function



 www.festo.com



-  Diameter
16 ... 63 mm
-  Torque
1.6 ... 112 Nm

General technical data									
Size	16	20	25	32	35	40	50	63	
Design	Rack and pinion								
Mode of operation	Double-acting								
Pneumatic connection									
DRRD-...	M5			G1/8			G1/4		G3/8
DRRD-...-PS1	M5						G1/8		-
Type of mounting									
With through-hole									
Via female thread									
Swivel angle									
DRRD-...	[°]	180 (→ 27)							
DRRD-...-PS1	[°]	90 ±10°							-
Cushioning with fixed stop									
DRRD-...-P	Elastic cushioning rings/pads at both ends							-	
DRRD-...-Y9	Linear shock absorber, self-adjusting at both ends								
DRRD-...-Y10 ¹⁾	-	Linear shock absorber, self-adjusting at both ends, hard			-	Linear shock absorber, self-adjusting at both ends, hard			
DRRD-...-Y12	Linear shock absorber, self-adjusting at both ends, external								
Repetition accuracy									
DRRD-...	[°]	< 0.05						≤0.03	
DRRD-...-PS1									
Approached from one end	[°]	0.1							-
Approached from both ends	[°]	0.7							-
Axial run-out ¹⁾	[mm]	< 0.05							
Max. axial load (static)	[N]	1500	2400	2400	3750	6100	6100	9000	11000
Assembly position	Any								

1) Not in combination with intermediate position DRRD-...-PS1

1) Axial run-out in new condition

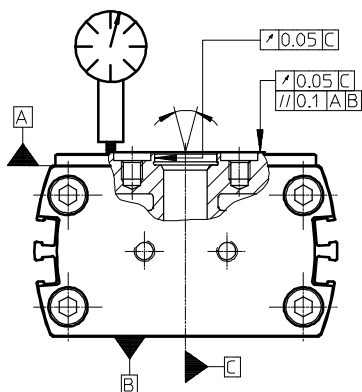

Twin-piston semi-rotary drives DRRD-16 ... 63

Technical data

Operating and environmental conditions		
Operating medium	Compressed air to ISO 8573-1:2010 [7:4:4]	
Note on operating/pilot medium	Lubricated operation possible (in which case lubricated operation will always be required)	
Operating pressure		
DRRD-...		
DRRD-...-P	[bar]	3 ... 8
DRRD-...-Y9/-Y10/-Y12	[bar]	2 ... 10
DRRD-...-PS1		
DRRD-...-P	[bar]	4 ... 8
DRRD-...-Y9/-Y12	[bar]	2 ... 10
Ambient temperature	[°C]	-10 ... +60
Storage temperature	[°C]	-20 ... +60
Degree of protection based on EN 60529		
DRRD-...-SG	IP65	

ATEX ¹⁾	
ATEX category for gas	II 2G
Ignition protection type for gas	c T4
ATEX category for dust	II 2D
Ignition protection type for dust	c T120°C
Explosion-proof ambient temperature	-10°C ≤ Ta ≤ +60°C
CE marking (see declaration of conformity)	To EU Explosion Protection Directive (ATEX)

1) Note the ATEX certification of the accessories.

Weight [g]								
Size	16	20	25	32	35	40	50	63
Basic drive with cushioning								
DRRD-...-P	640	839	1349	2815	4510	6070	-	-
DRRD-...-Y9/-Y10	650	883	1358	2976	4784	6424	11300	19100
DRRD-...-Y12	757	1132	1705	3760	5425	7160	12450	22400
Energy throughfeed (additional)								
DRRD-...-P	320	350	710	920	1090	1470	1950	2250
DRRD-...-P...E...	460	480	720	900	880	1770	2330	2610
Intermediate position (additional)								
DRRD-...-P	502	701	1078	2304	-	-	-	-
DRRD-...-Y9	511	720	1130	2450	3940	4380	8270	-
End-position locking (additional)								
DRRD-...-E1	166	382	370	600	900	900	1610	2380
Sensor mounting, external (additional)								
DRRD-...-R	110	192	192	366	485	485	810	1390

Twin-piston semi-rotary drives DRRD-16 ... 63

Technical data

Forces and torques									
Size		16	20	25	32	35	40	50	63
Theoretical torque at 6 bar	[Nm]	1.6	2.4	5.1	10.1	15.8	24.1	53	112
Max. permissible mass moment of inertia									
Rotation of end position to end position / intermediate position to end position									
DRRD-...-P	[kgcm ²]	175	400	900	1500	2500	6700	–	–
DRRD-...-Y9	[kgcm ²]	700	1250	1500	26000	15000	23000	40000	40000
DRRD-...-Y10	[kgcm ²]	–	–	5500	–	45000	67000	200000	420000
DRRD-...-Y12	[kgcm ²]	900	1500	5500	26000	45000	67000	200000	420000
Rotation of end position to intermediate position									
DRRD-...-P	[kgcm ²]	150	300	400	500	–	–	–	–
DRRD-...-Y9	[kgcm ²]	500	900	1500	8000	15000	23000	40000	–
DRRD-...-Y12	[kgcm ²]	500	900	1500	8000	15000	23000	40000	–

 **Note**
 If, in the end positions, a torque which exceeds 50% of the theoretical torque acts against the direction of rotation, no exact end position is guaranteed.
 This can be avoided by using external shock absorbers (Y12) or a semi-rotary drive with double the torque.

 **Note**
 The cushioning for the intermediate position corresponds to the cushioning for the basic drive. Except in the case of cushioning Y12: when shock absorbers Y9 are used.
 In combination with cushioning P, the intermediate position is only available for sizes 16 ... 32.

Materials

Sectional view

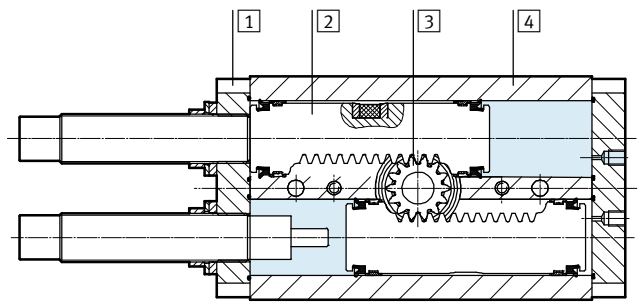

Semi-rotary drive	
1 Cap	Anodised wrought aluminium alloy
2 Piston	Stainless steel
3 Flanged shaft	Tempered steel
4 Housing	Wrought aluminium alloy, hard-anodised
Seals	NBR
Piston seal	TPE-U(PU)
Note on materials	RoHS-compliant
	Contains PWIS (paint-wetting impairment substances)

Twin-piston semi-rotary drives DRRD-16 ... 63

Technical data

Swivel angle

Fundamentally, the following applies:

Swivel angle $\alpha \geq$ cushioning angle β

Swivel angle $\alpha = 180^\circ + \Delta\alpha_{\text{clockwise}} + \Delta\alpha_{\text{anti-clockwise}}$

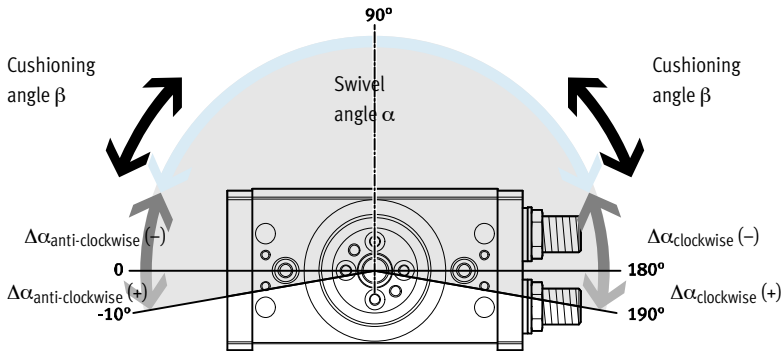

Size	16	20	25	32	35	40	50	63	
Swivel angle α	[°] 180								
Min. swivel angle α^1									
DRRD-...-P	[°] 36	45	33	33	36	23	-	-	
DRRD-...-Y9/-Y10	[°] 43	72	79	82	85	56	61	48	
DRRD-...-Y12	[°] 20	24	38	34	34	34	30	34	
DRRD-...-E1	[°] 60	60	60	55	57	57	62	55	
Max. swivel angle α^2									
DRRD-...	[°] 200								
DRRD-...-Y12	[°] 192	194	190	190	193	193	186	190	
Swivel angle adjustment α per side (infinitely adjustable)									
DRRD-...-P	[°] -100 ... +10							-	-
DRRD-...-Y9/-Y10	[°] ≥ -100 ... +10								
DRRD-...-Y12	[°] -94 ... +6	-85 ... +7	-88 ... +5	-93 ... +5	-86 ... +6.5		-86 ... +3	-91 ... +5	
Cushioning angle β									
DRRD-...-P	[°] 36	45	33	33	36	23	-	-	
DRRD-...-Y9/-Y10	[°] 43	72	79	82	85	56	61	48	
DRRD-...-Y12	[°] 10	12	19	17	17	17	15	17	

1) It is possible to set smaller swivel angles. However, this reduces the cushioning energy.
 2) The max. swivel angle is reduced by approx. 10° in combination with the external sensor mounting

Swivel angle adjustment

Clockwise direction of rotation:

- Swivel angle decreases

Anti-clockwise direction of rotation:

- Swivel angle increases

The swivel angle is adjusted via the cushioning components using an Allen key. Any reduction in the swivel angle should preferably be evenly split between the two end positions.

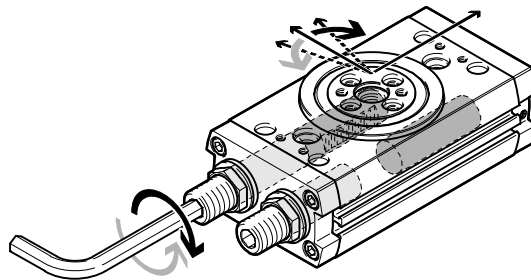

Swivel angle adjustment of the intermediate position → 39

Twin-piston semi-rotary drives DRRD-16 ... 63

Technical data

Max. permissible mass moment of inertia J at the flanged shaft as a function of swivel time s
(at room temperature and an operating pressure of 6 bar)

With cushioning P

Size 16

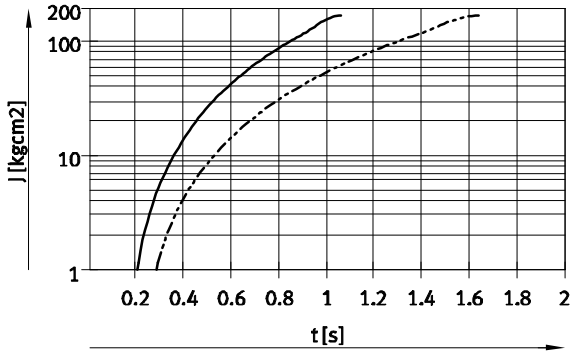

— DRRD-16-...-P (90°) Ranges → 1 ... 175 kgcm²
 - - - DRRD-16-...-P (180°) Ranges → 1 ... 175 kgcm²

Size 20

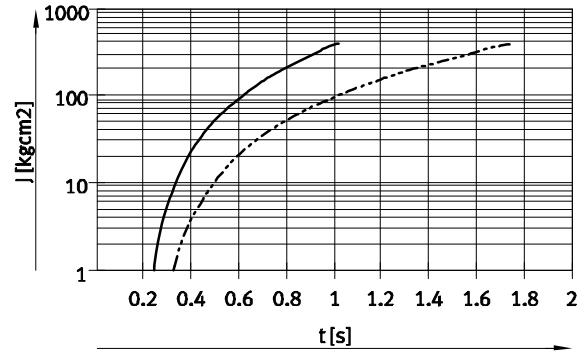

— DRRD-20-...-P (90°) Ranges → 1 ... 400 kgcm²
 - - - DRRD-20-...-P (180°) Ranges → 1 ... 400 kgcm²

Size 25

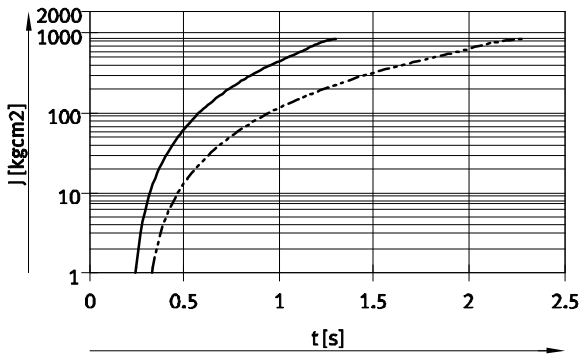

— DRRD-25-...-P (90°) Ranges → 1 ... 900 kgcm²
 - - - DRRD-25-...-P (180°) Ranges → 1 ... 900 kgcm²

Size 32

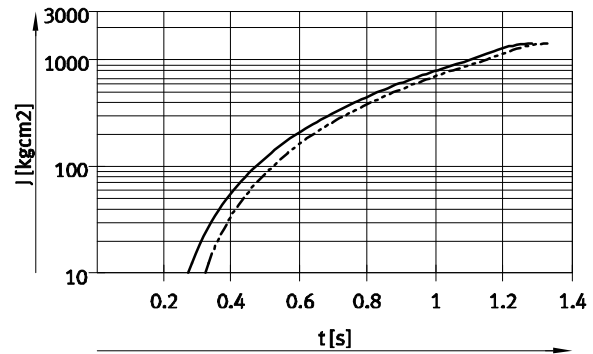

— DRRD-32-...-P (90°) Ranges → 10 ... 1500 kgcm²
 - - - DRRD-32-...-P (180°) Ranges → 10 ... 1500 kgcm²

Size 35

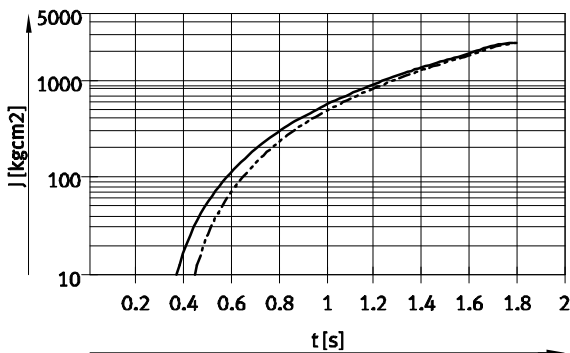

— DRRD-35-...-P (90°) Ranges → 10 ... 2500 kgcm²
 - - - DRRD-35-...-P (180°) Ranges → 10 ... 2500 kgcm²

Size 40

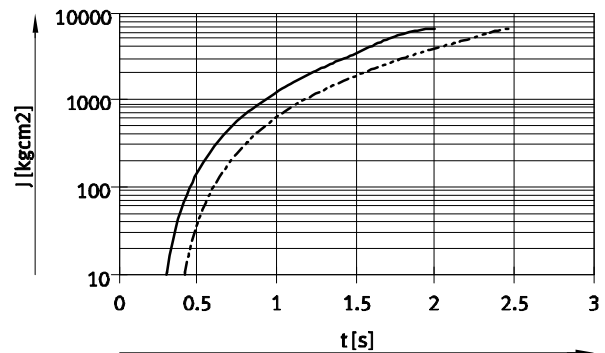

— DRRD-40-...-P (90°) Ranges → 10 ... 6700 kgcm²
 - - - DRRD-40-...-P (180°) Ranges → 10 ... 6700 kgcm²

Twin-piston semi-rotary drives DRRD-16 ... 63

Technical data

Max. permissible mass moment of inertia J at the flanged shaft as a function of swivel time s
(at room temperature and an operating pressure of 6 bar)

With cushioning Y9/Y10

Size 16

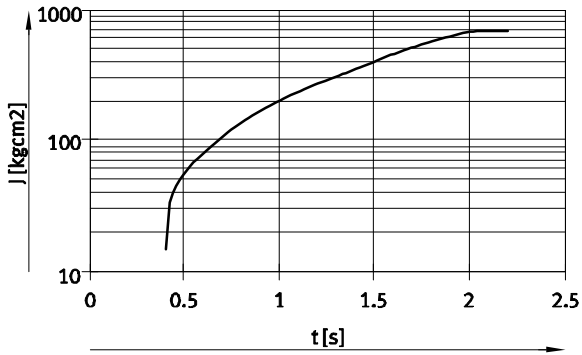

— DRRD-16-180-...-Y9 (180°) → Ranges → 15 ... 700 kgcm²

Size 20

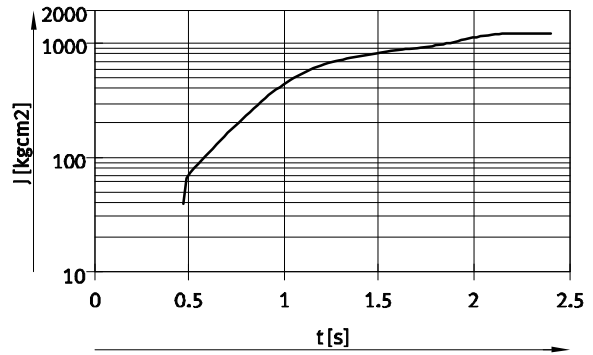

— DRRD-20-180-...-Y9 (180°) → Ranges → 40 ... 1250 kgcm²

Size 25

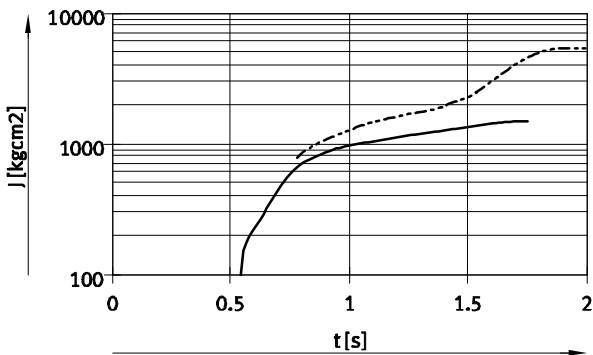

— DRRD-25-180-...-Y9 (180°) → Ranges → 100 ... 1500 kgcm²
 - - - DRRD-25-180-...-Y10 (180°) → Ranges → 800 ... 5500 kgcm²

Size 32

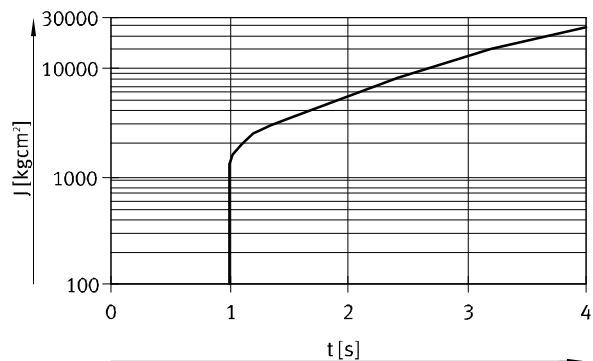

— DRRD-32-180-...-Y9 (180°) → Ranges → 100 ... 26000 kgcm²

Size 35

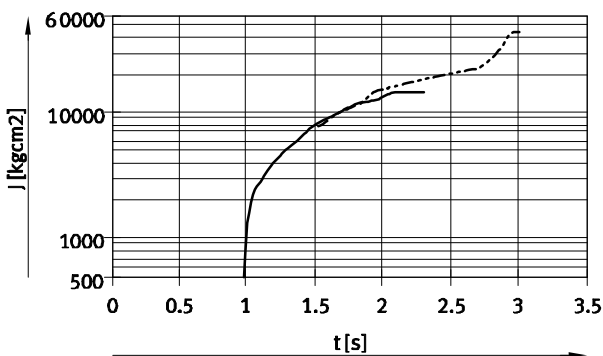

— DRRD-35-180-...-Y9 (180°) → Ranges → 500 ... 15000 kgcm²
 - - - DRRD-35-180-...-Y10 (180°) → Ranges → 8000 ... 45000 kgcm²

Size 40

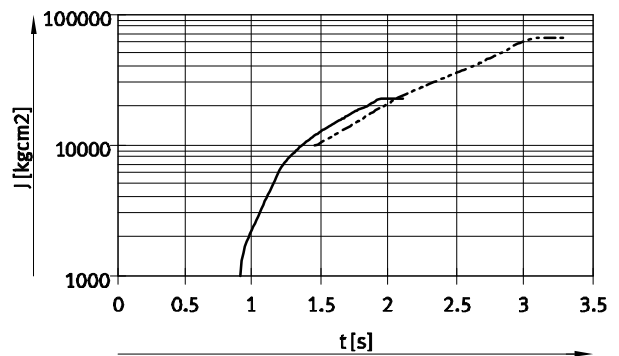

— DRRD-40-180-...-Y9 (180°) → Ranges → 1000 ... 23000 kgcm²
 - - - DRRD-40-180-...-Y10 (180°) → Ranges → 10000 ... 67000 kgcm²

Twin-piston semi-rotary drives DRRD-16 ... 63

Technical data

Max. permissible mass moment of inertia J at the flanged shaft as a function of swivel time s
(at room temperature and an operating pressure of 6 bar)

With cushioning Y9/Y10

Size 50

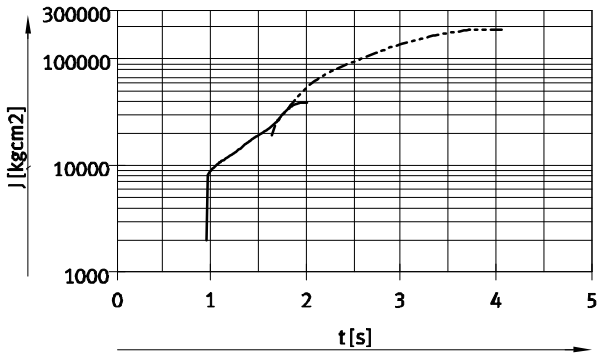

— DRRD-50-180-...-Y9 (180°) Ranges → 2000 ... 40000 kgcm²
 - - - DRRD-50-180-...-Y10 (180°) Ranges → 20000 ... 200000 kgcm²

Size 63

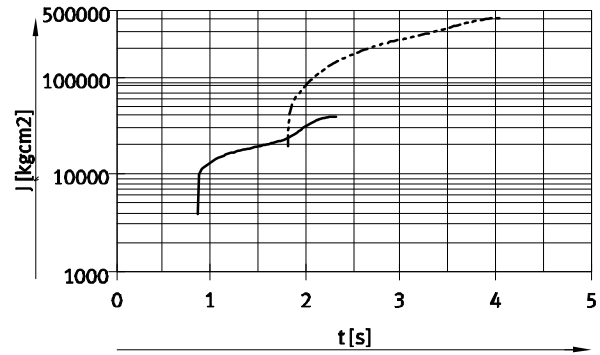

— DRRD-63-180-...-Y9 (180°) Ranges → 4000 ... 40000 kgcm²
 - - - DRRD-63-180-...-Y10 (180°) Ranges → 20000 ... 420000 kgcm²

With cushioning Y12

Size 16

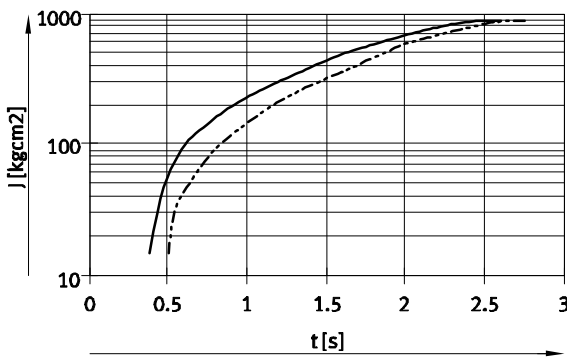

— DRRD-16-...-Y12 (90°) Ranges → 15 ... 900 kgcm²
 - - - DRRD-16-...-Y12 (180°) Ranges → 15 ... 900 kgcm²

Size 20

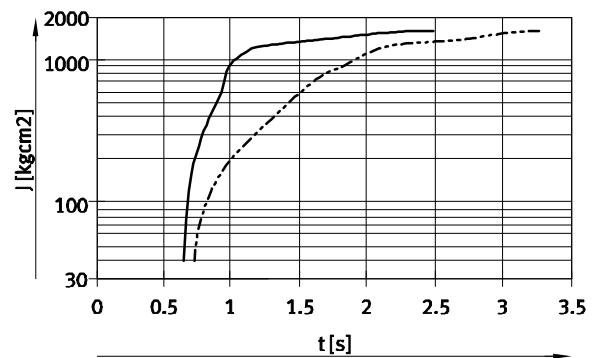

— DRRD-20-...-Y12 (90°) Ranges → 40 ... 1500 kgcm²
 - - - DRRD-20-...-Y12 (180°) Ranges → 40 ... 1500 kgcm²

Size 25

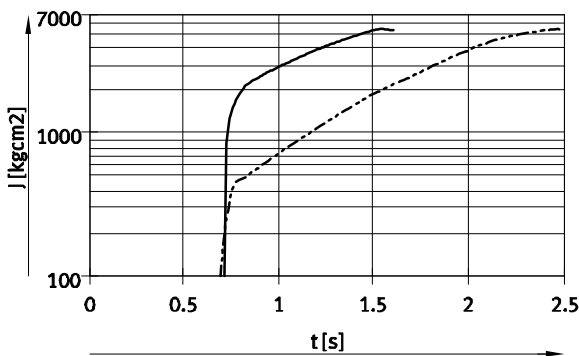

— DRRD-25-...-Y12 (90°) Ranges → 100 ... 5500 kgcm²
 - - - DRRD-25-...-Y12 (180°) Ranges → 100 ... 5500 kgcm²

Size 32

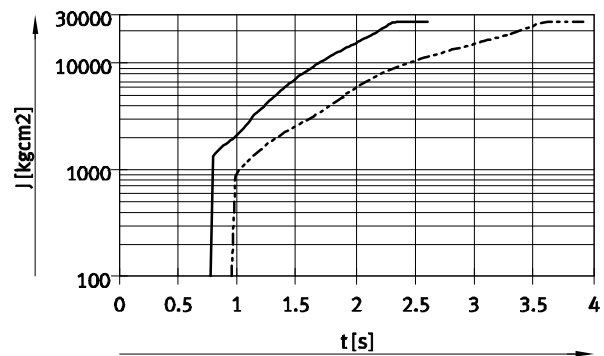

— DRRD-32-...-Y12 (90°) Ranges → 100 ... 26000 kgcm²
 - - - DRRD-32-...-Y12 (180°) Ranges → 100 ... 26000 kgcm²

Twin-piston semi-rotary drives DRRD-16 ... 63

Technical data

Max. permissible mass moment of inertia J at the flanged shaft as a function of swivel time s
(at room temperature and an operating pressure of 6 bar)

With cushioning Y12

Size 35

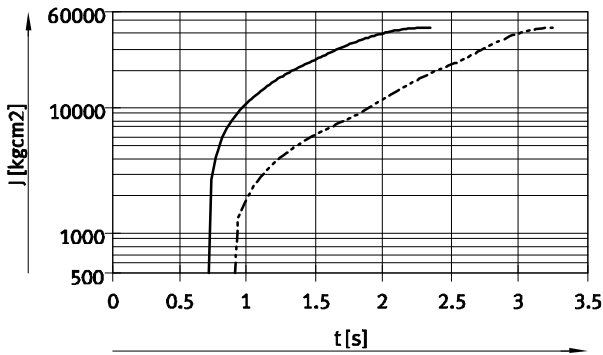

—	DRRD-35-...-Y12 (90°)	Ranges	→ 500 ... 45000 kgcm ²
- - -	DRRD-35-...-Y12 (180°)		→ 500 ... 45000 kgcm ²

Size 40

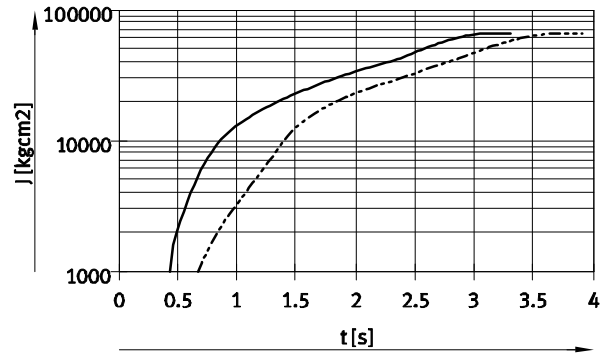

—	DRRD-40-...-Y12 (90°)	Ranges	→ 1000 ... 67000 kgcm ²
- - -	DRRD-40-...-Y12 (180°)		→ 1000 ... 67000 kgcm ²

Size 50

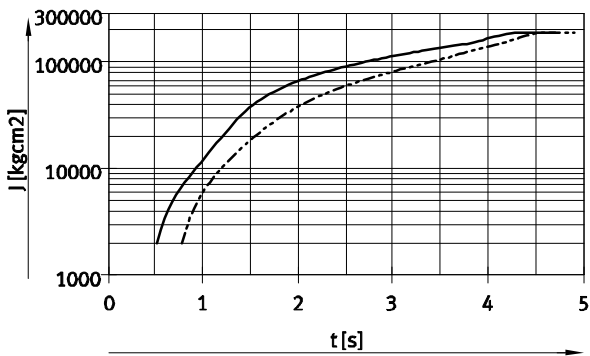

—	DRRD-50-...-Y12 (90°)	Ranges	→ 2000 ... 200000 kgcm ²
- - -	DRRD-50-...-Y12 (180°)		→ 2000 ... 200000 kgcm ²

Size 63

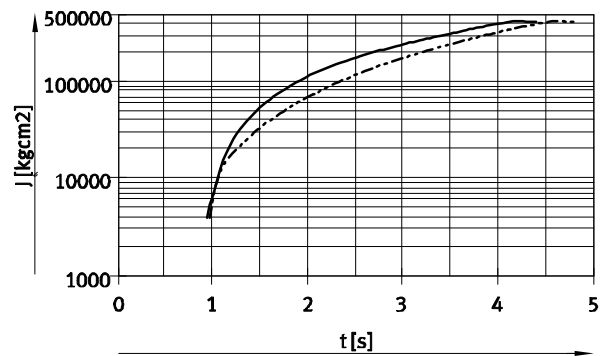

—	DRRD-63-...-Y12 (90°)	Ranges	→ 4000 ... 420000 kgcm ²
- - -	DRRD-63-...-Y12 (180°)		→ 4000 ... 420000 kgcm ²

Twin-piston semi-rotary drives DRRD-16 ... 63

Technical data

Max. dynamic load capacity at the flanged shaft

The zero point for the dimension Z is always the flange surface of the basic drive, regardless of the attachments (flange assembly).

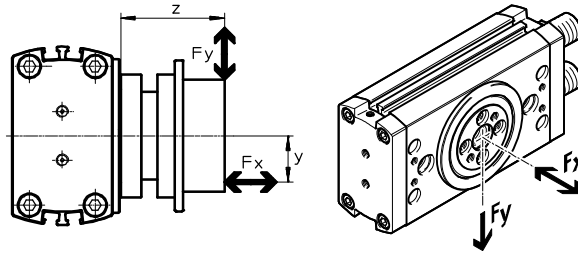

The following equation applies to combined loads (axial and radial):

$$\frac{F_{y(z)}}{F_{y, \max. (z)}} + \frac{F_{z(v)}}{F_{z, \max. (v)}} \leq 1$$

Max. dynamic radial force F_y as a function of distance z

Size 16/20

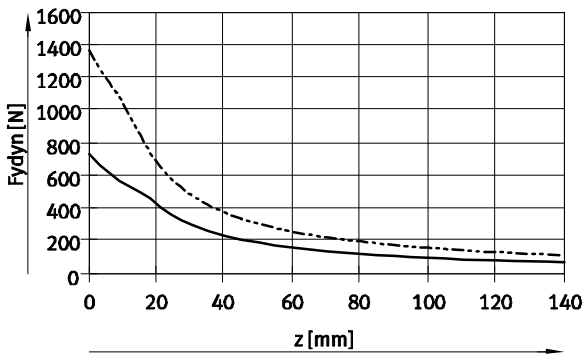

— DRRD-16
- - - DRRD-20

Size 25/32

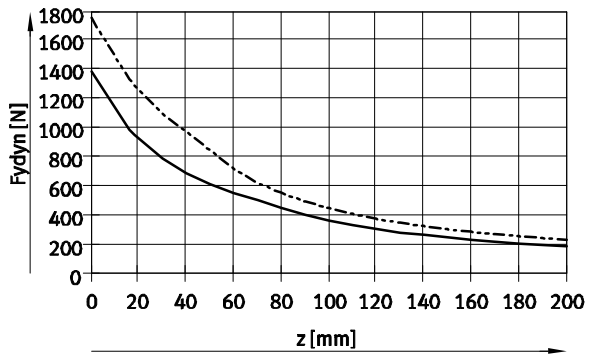

— DRRD-25
- - - DRRD-32

Size 35/40

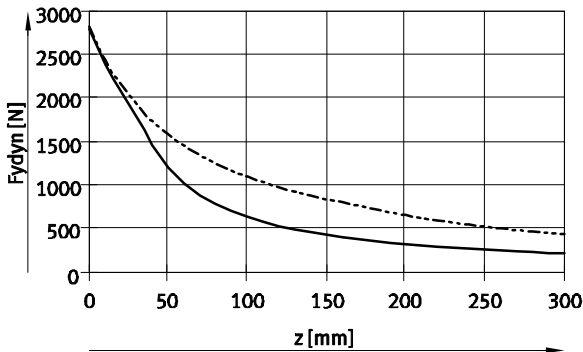

— DRRD-35
- - - DRRD-40

Size 50/63

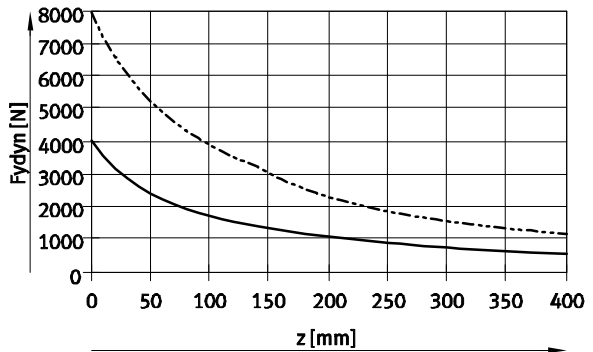

— DRRD-50
- - - DRRD-63

Twin-piston semi-rotary drives DRRD-16 ... 63

Technical data

Max. dynamic load capacity at the flanged shaft

The zero point for the dimension Z is always the flange surface of the basic drive, regardless of the attachments (flange assembly).

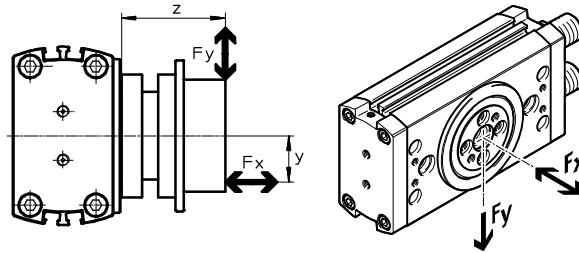

The following equation applies to combined loads (axial and radial):

$$\frac{F_{y(z)}}{F_{y, \max. (z)}} + \frac{F_{z(v)}}{F_{z, \max. (v)}} \leq 1$$

Max. dynamic axial force F_x as a function of distance y

Size 16/20

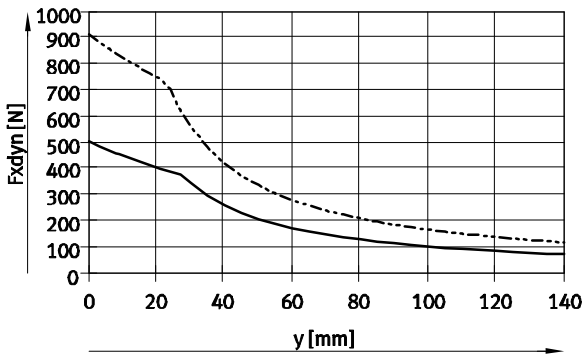

— DRRD-16
- - - DRRD-20

Size 25/32

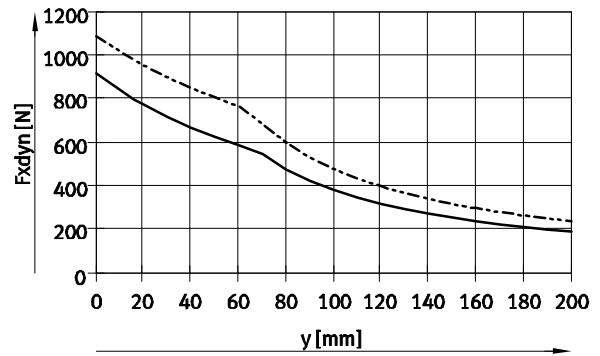

— DRRD-25
- - - DRRD-32

Size 35/40

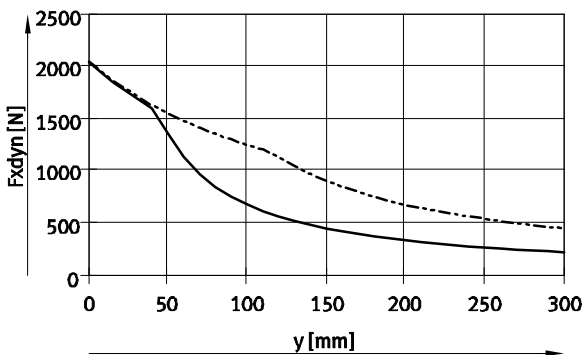

— DRRD-35
- - - DRRD-40

Size 50/63

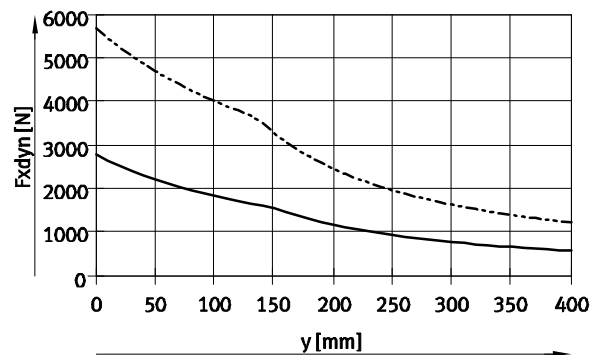

— DRRD-50
- - - DRRD-63

Twin-piston semi-rotary drives DRRD-16 ... 63

Technical data

Max. static load capacity at the flanged shaft

The zero point for the dimension Z is always the flange surface of the basic drive, regardless of the attachments (flange assembly).

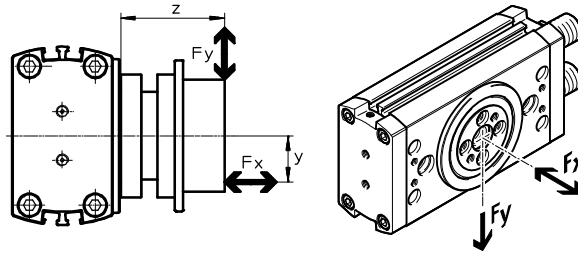

The following equation applies to combined loads (axial and radial):

$$\frac{F_y(z)}{F_{y, \max.}(z)} + \frac{F_z(v)}{F_{z, \max.}(v)} \leq 1$$

Max. static radial force F_y as a function of distance z

Size 16/20

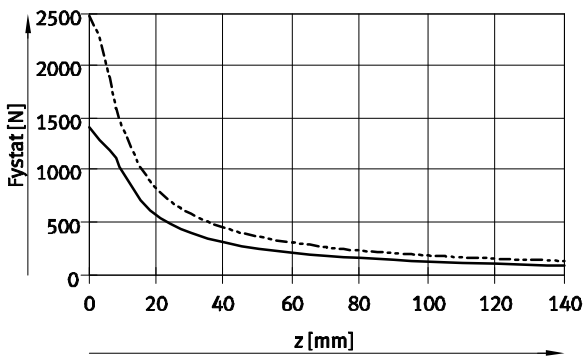

— DRRD-16
- - - DRRD-20

Size 25/32

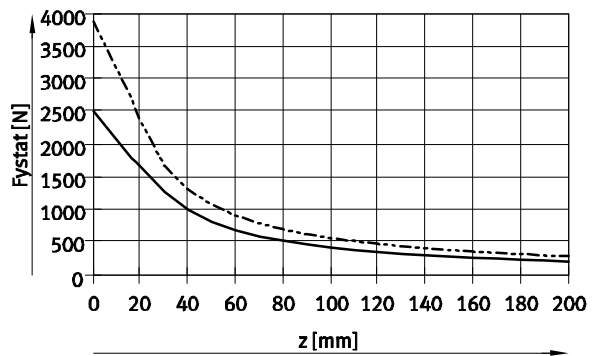

— DRRD-25
- - - DRRD-32

Size 35/40

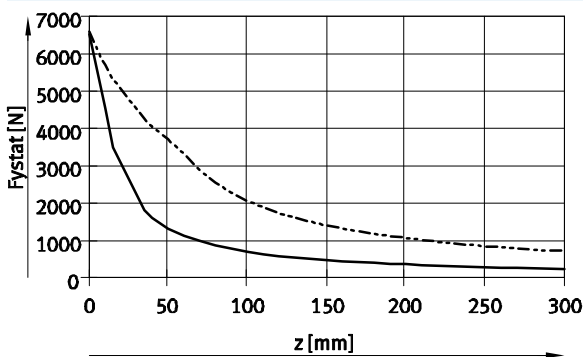

— DRRD-35
- - - DRRD-40

Size 50/63

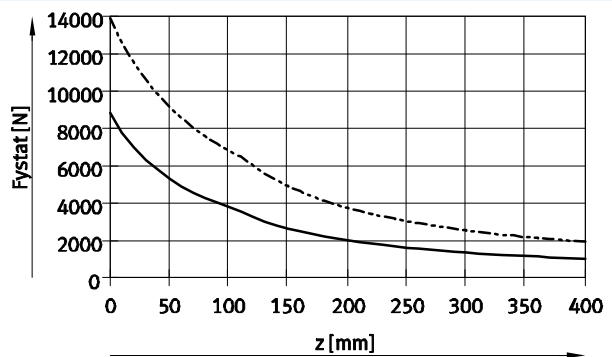

— DRRD-50
- - - DRRD-63

Twin-piston semi-rotary drives DRRD-16 ... 63

Technical data

Max. static load capacity at the flanged shaft

The zero point for the dimension Z is always the flange surface of the basic drive, regardless of the attachments (flange assembly).

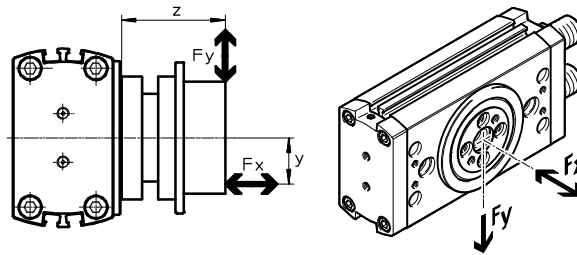

The following equation applies to combined loads (axial and radial):

$$\frac{F_{y(z)}}{F_{y, \max. (z)}} + \frac{F_{z(v)}}{F_{z, \max. (v)}} \leq 1$$

Max. static axial force F_x as a function of distance y

Size 16/20

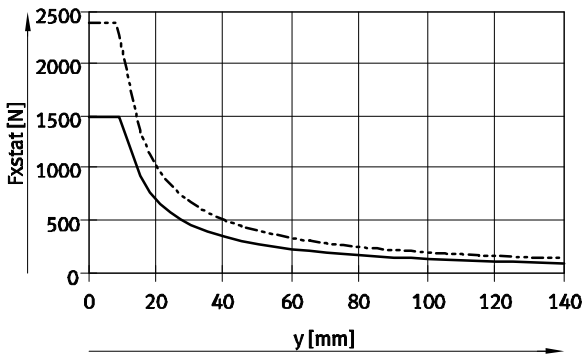

— DRRD-16
- - - DRRD-20

Size 25/32

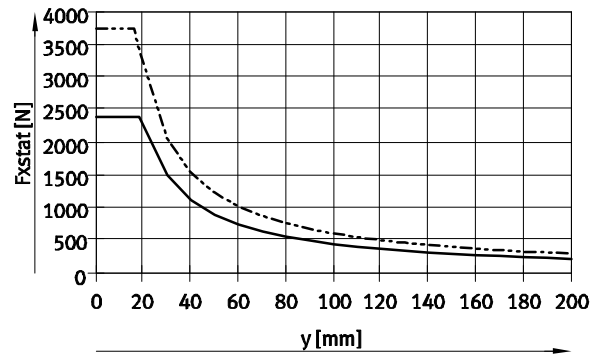

— DRRD-25
- - - DRRD-32

Size 35/40

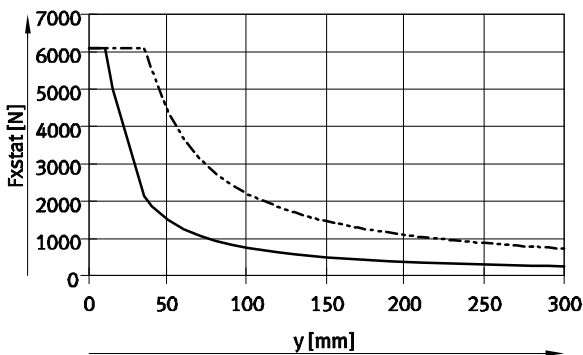

— DRRD-35
- - - DRRD-40

Size 50/63

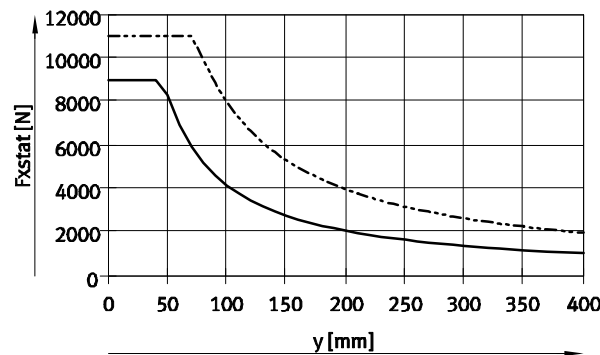

— DRRD-50
- - - DRRD-63

Twin-piston semi-rotary drives DRRD-16 ... 63

Technical data

Energy throughfeed
DRRD-...-P...E...



Function **Benefits**

Electrical signals or compressed air can be transferred through the hollow shaft using the energy throughfeed.

- Fast and easy supply of the parts connected to the flange (e.g. gripper)
- Tubing and electrical cables are not damaged by the rotation
- Two variants available:
 - Pneumatic
 - Pneumatic and electrical
- Different number of connections depending on the size

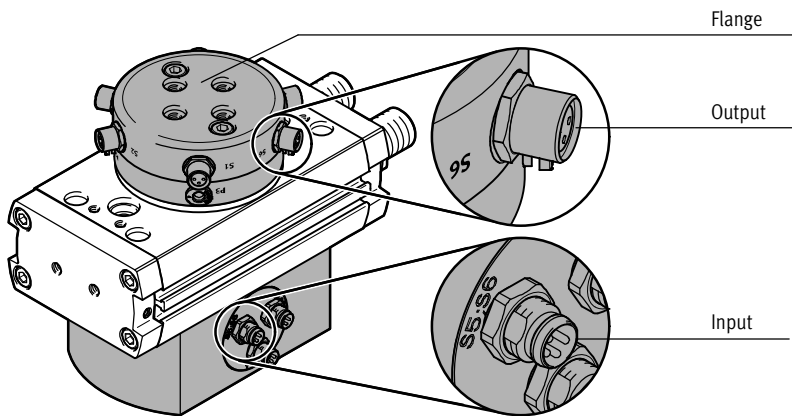

 **Note**
Only connecting cables with straight connectors can be used (→ 59).

Technical data						
Size	16/20		25/32/35		40/50/63	
Variant	Pneumatic	Pneumatic/ electric	Pneumatic	Pneumatic/ electric	Pneumatic	Pneumatic/ electric
Order code	P2	P2E2	P4	P4E6	P8	P8E8
Pneumatic						
Number of pneumatic channels	2	2	4	4	8	8
Tubing O.D.	4					
Max. operating pressure [bar]	8					
Connection	M5					
Flow rate per channel [l/min.]	86				33	
Electric						
Number of electric signals	–	2	–	6	–	8
Rated voltage [V DC]	–	30	–	30	–	30
Max. current ¹⁾ [A]	1.5					
Connection	M8				M12	

1) The positive and negative lines of each electrical connection are linked. The combined maximum peak current for this common positive and negative line is also 1.5 A.

Twin-piston semi-rotary drives DRRD-16 ... 63

Technical data

DRRD-...-P...E... – Energy throughfeed
Pin allocation

Size 16/20

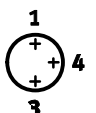
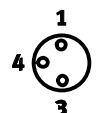
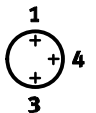
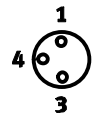
Input M8 plug				Output M8 socket			
Designation	Signals	Pin ¹⁾	Circuit diagram	Circuit diagram	Pin ¹⁾	Signals	Designation
S1	+ - Sig 1	1			1	+ - Sig 1	S1
		3			3		
		4			4		
S2	+ - Sig 2	1			1	+ - Sig 2	S2
		3			3		
		4			4		

1) Pin 1 (+) and Pin 3 (-) are connected to each other between plugs S1 and S2. Unused plugs and sockets should therefore be protected with the cover caps.

Pin allocation

Sizes 25/32/35

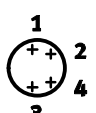
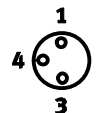
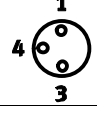
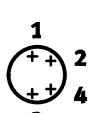
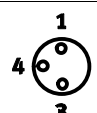
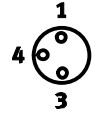
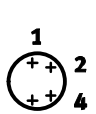
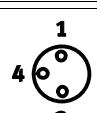
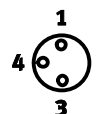
Input M8 plug				Output M8 socket			
Designation	Signals	Pin ¹⁾	Circuit diagram	Circuit diagram	Pin ¹⁾	Signals	Designation
S1;S2	+ Sig 2 - Sig 1	1			1	+ - Sig 1	S1
		2			3		
		3			1	+ - Sig 2	S2
		4			3		
S3;S4	+ Sig 4 - Sig 3	1			1	+ - Sig 3	S3
		2			3		
		3			1	+ - Sig 4	S4
		4			3		
S5;S6	+ Sig 6 - Sig 5	1			1	+ - Sig 5	S5
		2			3		
		3			1	+ - Sig 6	S6
		4			3		

1) Pin 1 (+) and Pin 3 (-) are connected to each other between plugs S1 ... S6. Unused plugs and sockets should therefore be protected with the cover caps.

Twin-piston semi-rotary drives DRRD-16 ... 63

Technical data

DRRD-...-P...E... – Energy throughfeed

Size 40/50/63

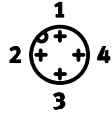
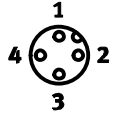
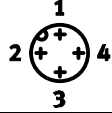
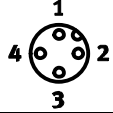
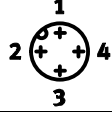
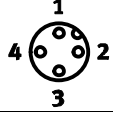
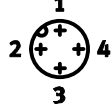
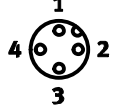
Input M12 plug				Output M12 socket			
Designation	Signals	Pin ¹⁾	Circuit diagram	Circuit diagram	Pin ¹⁾	Signals	Designation
S1;S2	+ Sig 2 - Sig 1	1 2 3 4			1 2 3 4	+ Sig 2 - Sig 1	S1;S2
S3;S4	+ Sig 4 - Sig 3	1 2 3 4			1 2 3 4	+ Sig 4 - Sig 3	S3;S4
S5;S6	+ Sig 6 - Sig 5	1 2 3 4			1 2 3 4	+ Sig 6 - Sig 5	S5;S6
S7;S8	+ Sig 8 - Sig 7	1 2 3 4			1 2 3 4	+ Sig 8 - Sig 7	S7;S8

1) Pin 1 (+) and Pin 3 (-) are connected to each other between plugs S1 ... S8. Unused plugs and sockets should therefore be protected with the cover caps.

Twin-piston semi-rotary drives DRRD-16 ... 63

Technical data

Intermediate position DRRD-...-PS1



Function

The intermediate-position module enables an additional position to be set, at half of the nominal rotation angle (90°). A piston with two screwed-in guide

systems is supplied with compressed air and moves the racks of the unpressurised semi-rotary drive until both pistons rest on the plungers positioned in the guide systems and

are held in this position. The movement is cushioned using a shock absorber. To move to the other end position, the semi-rotary drive is supplied with

compressed air. The piston of the basic drive thus moves the entire intermediate-position piston back into its initial position.

Key features

- Setting range: 90° ±10°
- Cushioning variants: P, Y9
- Can be approached and travelled through from both end positions
- Position sensing of the intermediate position possible

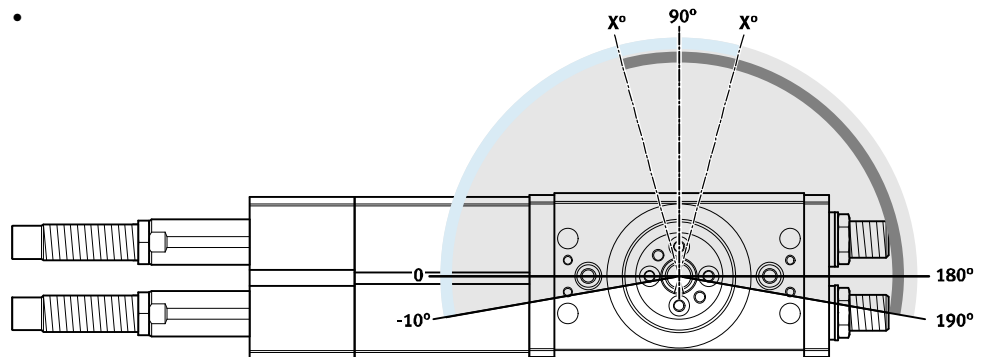

Setting the swivel speed

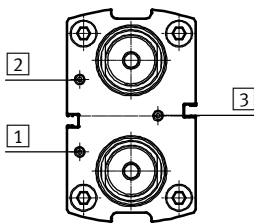

The following movements are set via supply ports **1** and **2**.
End position → intermediate position
Both directions can be adjusted separately from each other.

Semi-rotary module and intermediate-position module must only be operated with controlled air flow. The throttles should be connected as close as possible to the semi-rotary module (e.g. one-way flow control valve GRLA-...) → 61.

In the event of pressure failure, the payload may hit an end position in an uncontrolled manner. In order to prevent this, piloted non-return valves HGL or an air pressure reservoir VZS are recommended → 61

The following movement is set via supply port **3**.
Intermediate position → end position
Both directions are set simultaneously.

Twin-piston semi-rotary drives DRRD-16 ... 63

Technical data

DRRD-...-PS1 – Intermediate position

Swivel angle adjustment

By pushing the shock absorber as far as the stop, the flanged shaft of the semi-rotary drive rotates into the intermediate position.

In delivered state, the intermediate position is set to 90°. The swivel angle

can be adjusted by ±10° by screwing the shock absorber in or out.

If the setting dimension X_{max} is exceeded, the shock absorber can no longer completely cushion the movement.

If the setting dimension X_{min} is fallen below, the shock absorber not only cushions the intermediate position, but also the end position of the semi-rotary drive.

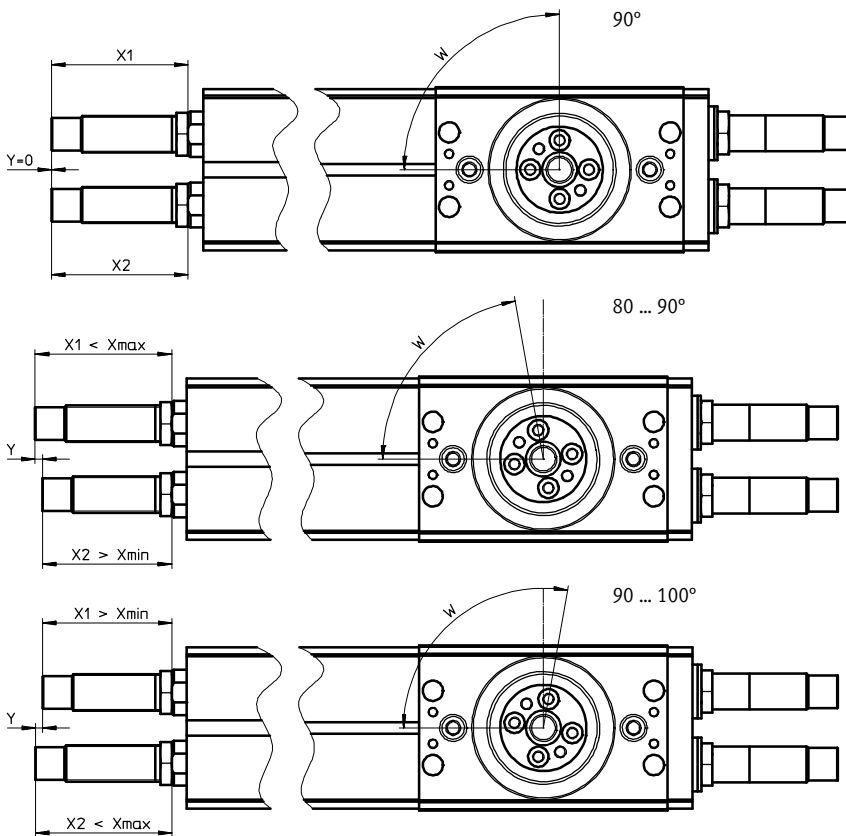

Size		16	20	25	32	35	40	50
Setting dimension X								
DRRD-...-P								
X_{min}	[mm]	7.7	14.9	14.2	12.5	-	-	-
X_{max}	[mm]	10.1	17.8	20.6	23.2	-	-	-
DRRD-...-Y9								
X_{min}	[mm]	29.6	41.8	56.9	70.3	88.6	86.7	114
X_{max}	[mm]	32	44.5	60.4	78.5	96.2	92.7	128
Dimension Y for 10°swivel angle change	[mm]	2.3	2.4	3.2	3.7	3.7	5.6	8

Twin-piston semi-rotary drives DRRD-16 ... 63

Technical data

DRRD-...-PS1 – Intermediate position

Control variants

- 1 Using 1x 5/3-way valve and 1x 3/2-way valve

Circuit diagram

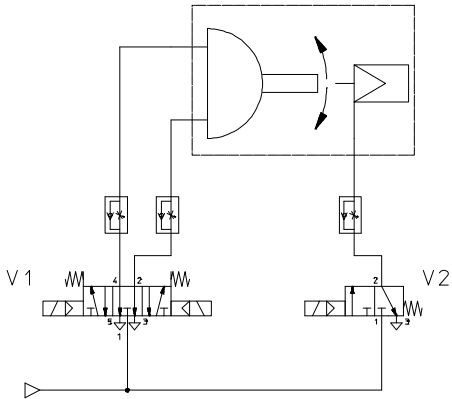

Control sequence

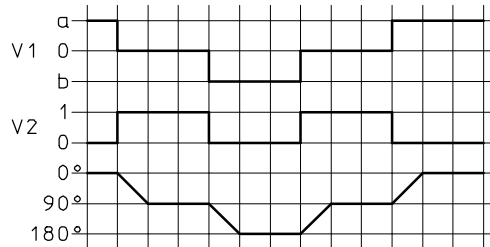

- 2 Using 3x 3/2-way valve

Circuit diagram

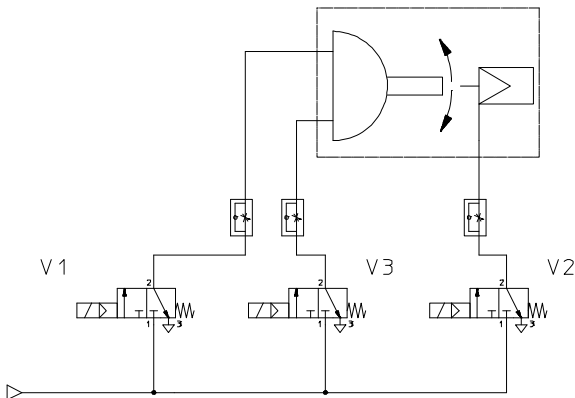

Control sequence

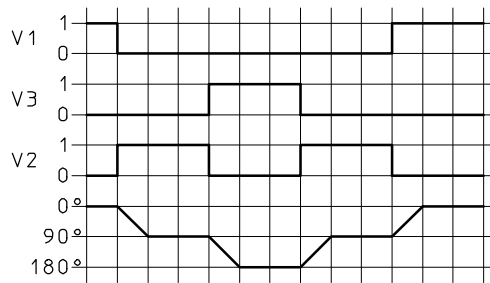

- 3 Using 1x 5/3-way valve and 3x 3/2-way valve

This variant enables shorter swivel times when swivelling through 180° (from end position to end position).

Circuit diagram

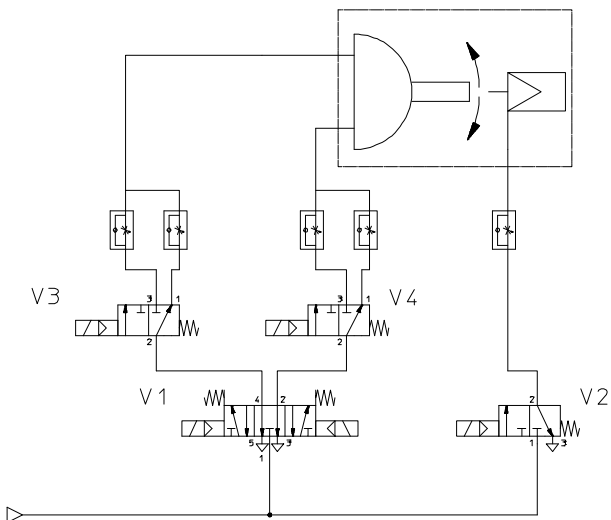

Control sequence

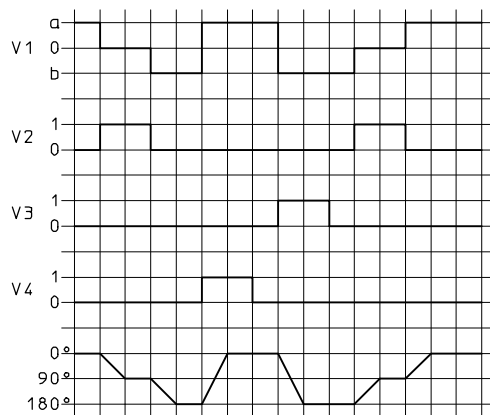

Twin-piston semi-rotary drives DRRD-16 ... 63

Technical data

DRRD-...-PS1 – Intermediate position

Max. permissible mass moment of inertia J at the flanged shaft as a function of swivel time s
(at room temperature and an operating pressure of 6 bar)

Size 16

End position to intermediate position

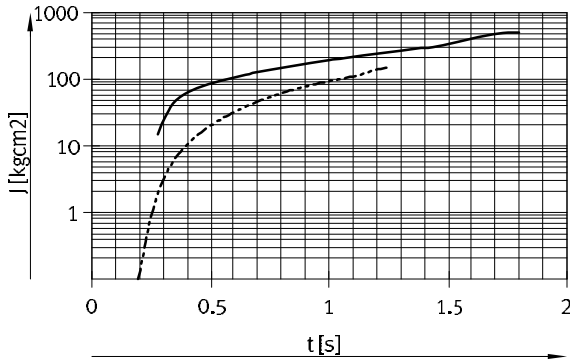

— DRRD-16-Y9-PS1 Ranges → 15 ... 500 kgcm²
 - - - DRRD-16-P-PS1 Ranges → 0 ... 150 kgcm²

Intermediate position to end position

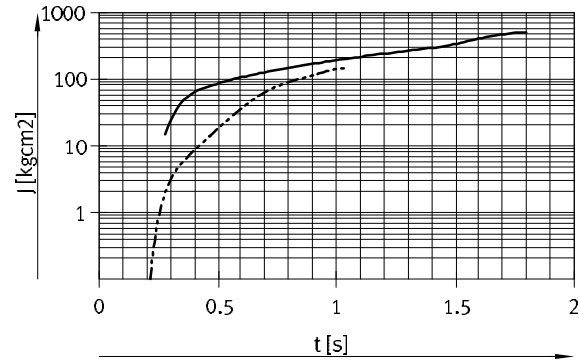

— DRRD-16-Y9-PS1 Ranges → 15 ... 500 kgcm²
 - - - DRRD-16-P-PS1 Ranges → 0 ... 150 kgcm²

Size 20

End position to intermediate position

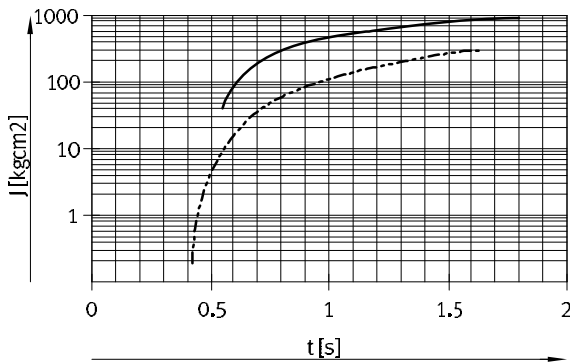

— DRRD-20-Y9-PS1 Ranges → 40 ... 900 kgcm²
 - - - DRRD-20-P-PS1 Ranges → 0 ... 300 kgcm²

Intermediate position to end position

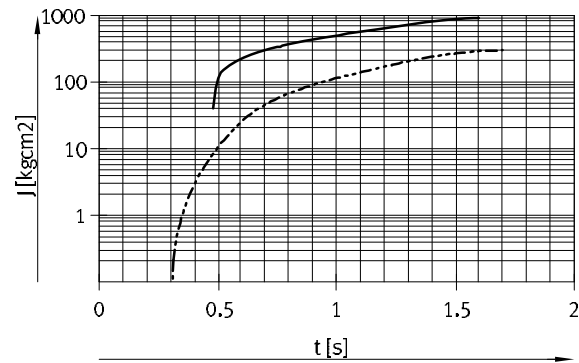

— DRRD-20-Y9-PS1 Ranges → 40 ... 900 kgcm²
 - - - DRRD-20-P-PS1 Ranges → 0 ... 300 kgcm²

Twin-piston semi-rotary drives DRRD-16 ... 63

Technical data

DRRD-...-PS1 – Intermediate position

Max. permissible mass moment of inertia J at the flanged shaft as a function of swivel time s
(at room temperature and an operating pressure of 6 bar)

Size 25

End position to intermediate position

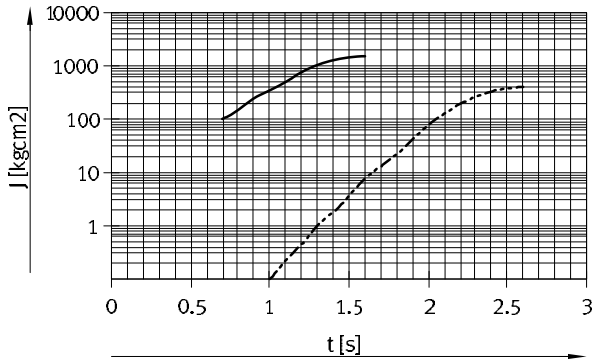

——— DRRD-25-Y9-PS1 → 100 ... 1500 kgcm²
 - - - - - DRRD-25-P-PS1 → 0 ... 400 kgcm²

Intermediate position to end position

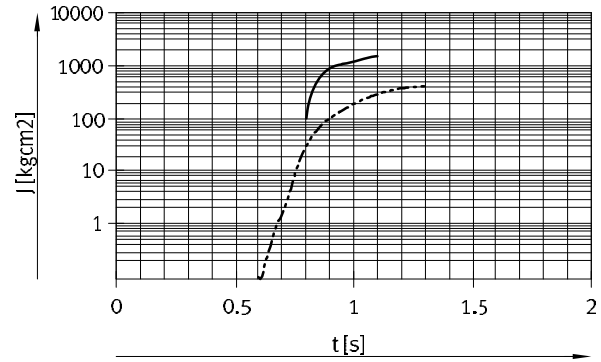

——— DRRD-25-Y9-PS1 → 100 ... 1500 kgcm²
 - - - - - DRRD-25-P-PS1 → 0 ... 400 kgcm²

Size 32

End position to intermediate position

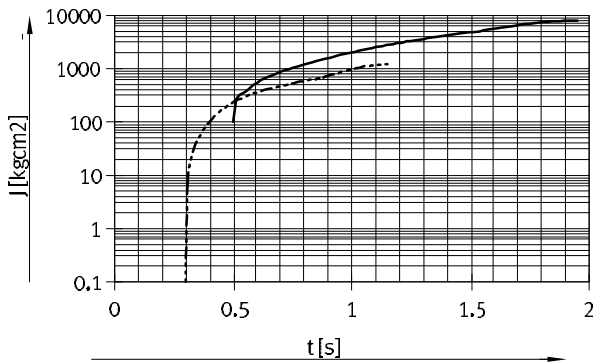

——— DRRD-32-Y9-PS1 → 100 ... 8000 kgcm²
 - - - - - DRRD-32-P-PS1 → 0 ... 500 kgcm²

Intermediate position to end position

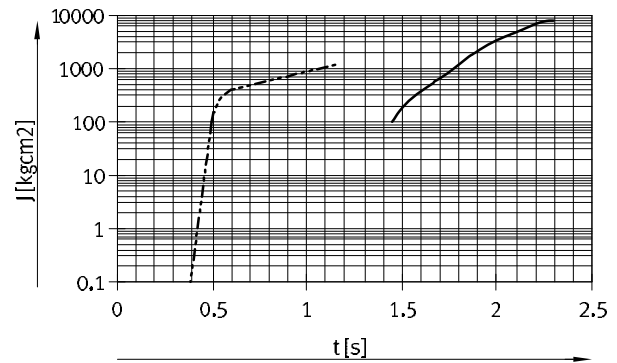

——— DRRD-32-Y9-PS1 → 100 ... 8000 kgcm²
 - - - - - DRRD-32-P-PS1 → 0 ... 500 kgcm²

Twin-piston semi-rotary drives DRRD-16 ... 63

Technical data

DRRD-...-PS1 – Intermediate position

Max. permissible mass moment of inertia J at the flanged shaft as a function of swivel time s
(at room temperature and an operating pressure of 6 bar)

Size 35

End position to intermediate position

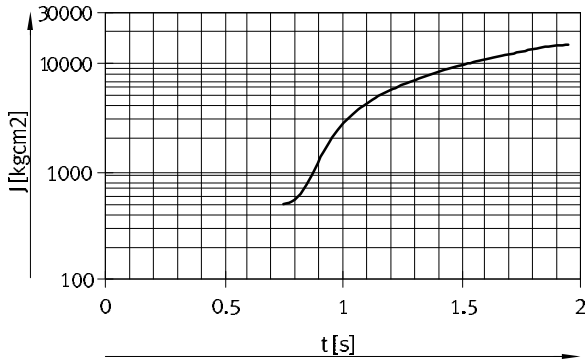

DRRD-35-Y9-PS1
Ranges
→ 500 ... 15000 kgcm²

Intermediate position to end position

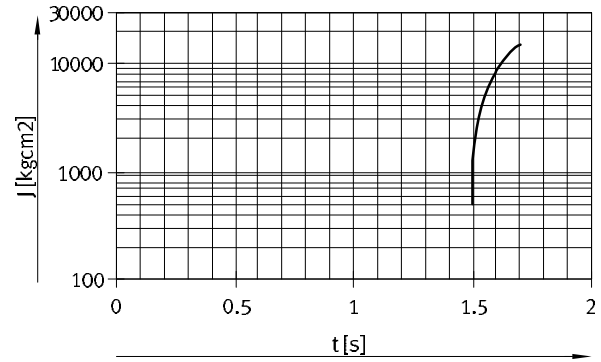

DRRD-35-Y9-PS1
Ranges
→ 500 ... 15000 kgcm²

Size 40

End position to intermediate position

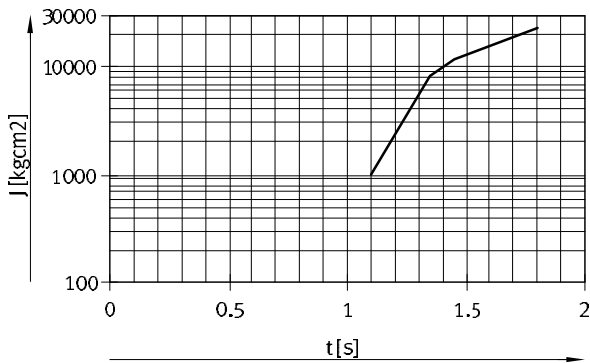

DRRD-40-Y9-PS1
Ranges
→ 1000 ... 23000 kgcm²

Intermediate position to end position

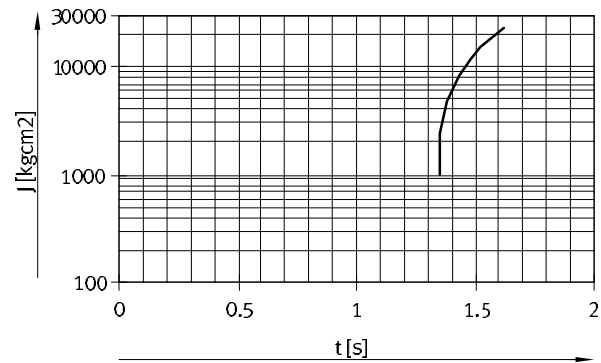

DRRD-40-Y9-PS1
Ranges
→ 1000 ... 23000 kgcm²

Twin-piston semi-rotary drives DRRD-16 ... 63

Technical data

DRRD-...-PS1 – Intermediate position

Max. permissible mass moment of inertia J at the flanged shaft as a function of swivel time s (at room temperature and an operating pressure of 6 bar)

Size 50

End position to intermediate position

Intermediate position to end position

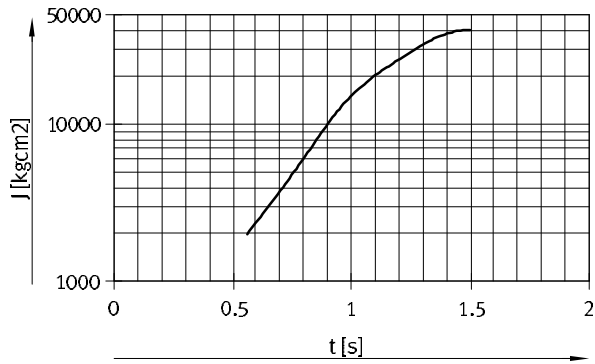

DRRD-50-Y9-PS1

Ranges
→ 2000 ... 40000 kgcm²

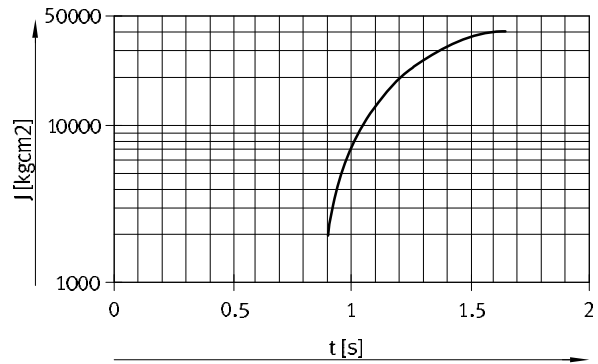

DRRD-50-Y9-PS1

Ranges
→ 2000 ... 40000 kgcm²

Twin-piston semi-rotary drives DRRD-16 ... 63

Technical data

Dimensions

Download CAD data → www.festo.com

The semi-rotary drive must only be operated with controlled air flow. The throttles should be connected as close as possible to the semi-rotary drive (e.g. one-way flow control valve GRLA-...) → 61.

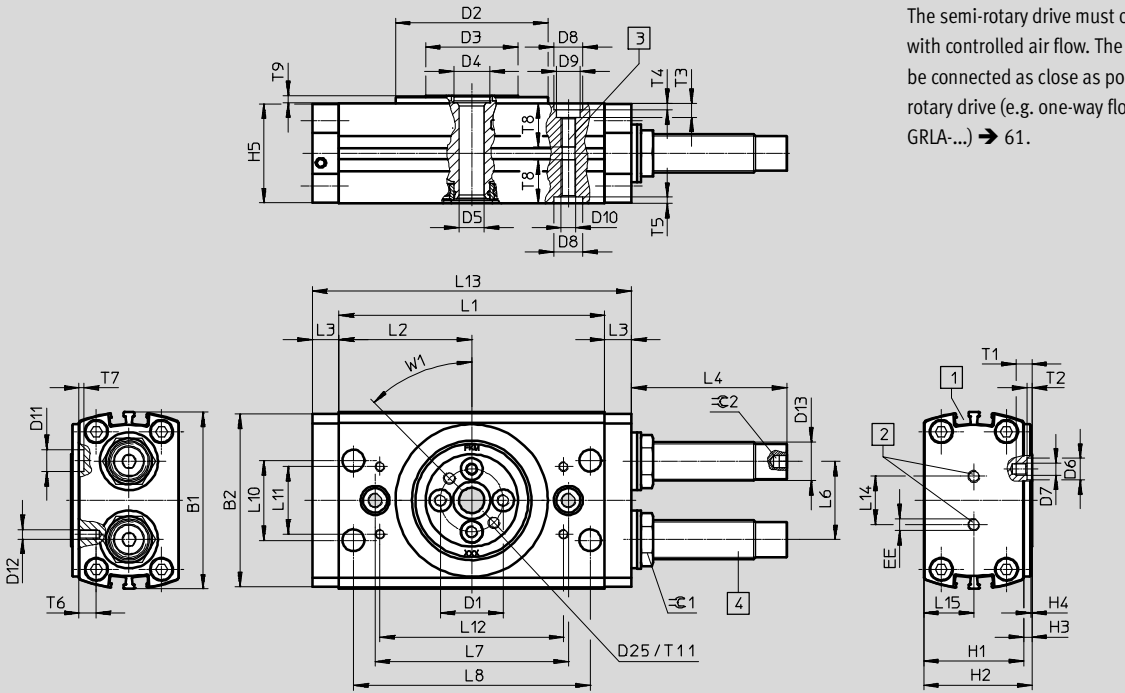

DRRD-32 ... 40

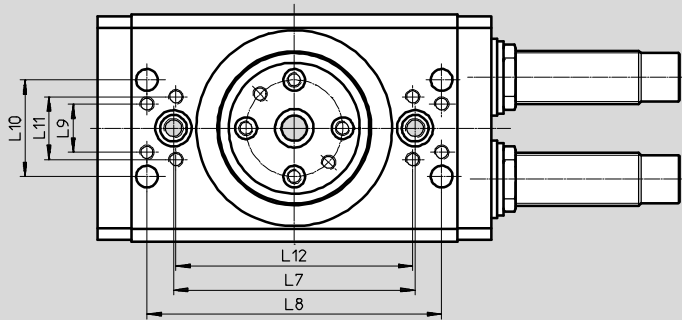

DRRD-...-P

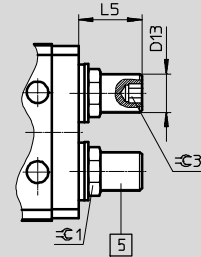

DRRD-50/63

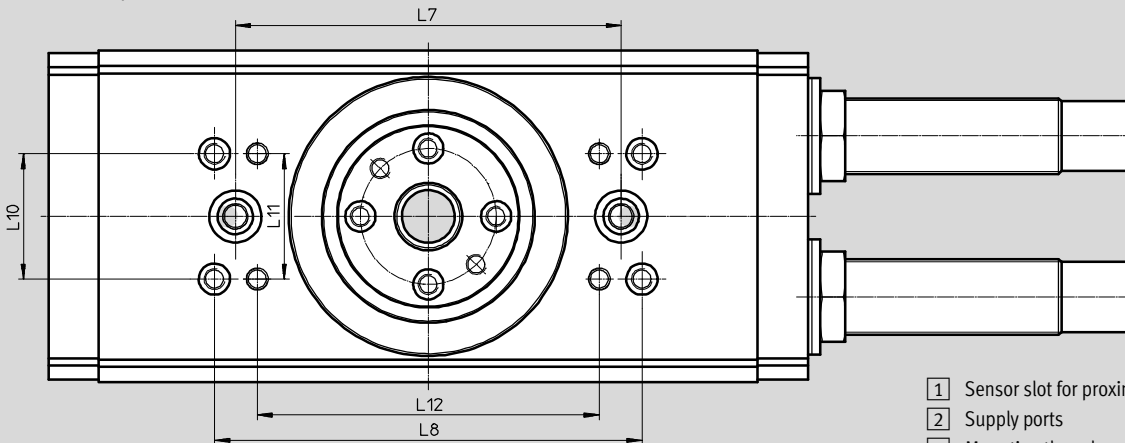

- 1 Sensor slot for proximity sensor
- 2 Supply ports
- 3 Mounting thread
- 4 Shock absorber (DRRD-...-Y9/-Y10)
- 5 Cushioning component (DRRD-...-P)

Twin-piston semi-rotary drives DRRD-16 ... 63

Technical data

Size	B1 ±0.25	B2	D1 ∅ ±0.025	D2 ∅ h7	D3 ∅	D4 ∅ H7	D5 ∅ +0.15/-0.05	D6 ∅ H7	D7	D8 ∅ H7	D9 ∅	D10
16	58	56.2	21	50	32	12	8	7	M4	9	8	M5
20	65	63.4	24	56	34.9	12	8	7	M4	9	8	M5
25	73.2	71.5	26	63	38.3	15	10.5	9	M5	12	10	M6
32	94	92.6	40	81	54.2	15	10.5	9	M6	15	11	M8
35	106	104	45	91	59.9	25	10.5	9	M6	15	11	M8
40	113	111	45	91	59.9	25	21	9	M6	15	14	M10
50	132	139.7	54	110	73	25	21	12	M8	15	14	M10
63	159	157	63	135	82.8	25	21	15	M10	25	17	M12

Size	D11 ∅ H7	D12	D13	D25	H1 ±0.1	H2 +0.2/-0.1	H3 +0.3/-0.2	H4	H5	L1 ±0.1	L2	L3 ±0.1
16	7	M3	M10x1	M4	33	35.6	2.6	0.5	32.6	84	42	10.5
20	9	M4	M12x1	M5	36	39.6	3.6	0.5	35.6	86	43	11
25	9	M4	M16x1	M5	41.4	44.7	3.3	0.5	41	110	55	11
32	9	M6	M22x1.5	M6	50	55.5	5.5	1	49.6	135	67.5	14
35	9	M6	M26x1.5	M6	63	67	4	1	62.2	148	74	15
40	9	M6	M26x1.5	M6	68	72	4	1	67.2	199	99.5	15
50	15	M8	M30x1.5	M8	78	83	5	1	77.2	262	131	20
63	15	M10	M37x1.5	M10	100	107	7	2	99.2	335	167.5	25

Size	L6	L7 ±0.02	L8 ±0.2	L9 ±0.15	L10 ±0.02	L11 ±0.15	L12 ±0.2	L13	L14	L15 -0.1	T1	T2 +0.1
16	23.2	64	74	-	26	22	61	105	20	16.3	5.6	1.6
20	26	70	74	-	33	14	80	108	20	17.8	6	1.6
25	32.4	80	98	-	33	14	98	132	20	20.5	6.6	2.1
32	42.2	100	122	20	40	26	98	163	30	24.8	8	2.1
35	49.6	120	130	44	26	44	105	178	42	31.1	8	2.1
40	56	120	130	44	26	44	105	229	42	33.6	8	2.1
50	64	160	160	34	34	54	132	302	50	39	10.6	2.6
63	78	170	190	60	60	60	149	385	50	49.6	14	3.1

Size	T3	T4 +0.1	T5 +0.3/-0.2	T6	T7 +0.1	T8	T9	T11	EE	W1	∠ 1	∠ 2	∠ 3
16	4.7	2.1	2.1	6.3	1.6	15	2.6	5.6	M5	45°	13	3	5
20	4.7	2.1	2.1	6.3	2.1	15	2.6	5.6	M5	45°	15	4	6
25	5.7	2.6	2.6	7	2.1	18	3.1	5.5	M5	45°	19	5	8
32	6.5	3.1	3.1	7.8	2.1	23.1	3.1	8	G $\frac{1}{8}$	45°	27	5	10
35	6.5	3.1	3.1	8.5	2.1	22.6	3.5	8	G $\frac{1}{8}$	45°	32	6	10
40	8.6	3.1	3.1	9	2.1	32	3.5	8	G $\frac{1}{8}$	45°	32	6	10
50	8.6	3.1	3.1	10.5	3.1	30	3.5	10	G $\frac{1}{4}$	45°	36	8	-
63	11	3.5	3.5	14	3.1	40	3.5	10	G $\frac{3}{8}$	45°	46	8	-

Size	Dimension with 180° swivel angle		Swivel angle adjustment range		
	L4	L5	L4 min./max.	L5 min./max.	1 mm = ...°
16	37	17.6	-20/+1.5	-12/+1.4	8.7
20	41.8	18	-21.1/+1.5	-11/+1.4	9
25	63	24.3	-28.9/+1.9	-15/+1.8	6.6
32	78.3	29.5	-34.7/+2.4	-19/+2.3	5.6
35	97.5	40.9	-34.7/+2.4	-27/+2.3	5.6
40	98.2	41.6	-53/+3.2	-28/+3.1	3.6
50	126	-	-74.5/+4.4	-	2.6
63	120	-	-71.7/+7.1	-	1.9

Twin-piston semi-rotary drives DRRD-16 ... 63

Technical data

Dimensions – Variants

Download CAD data → www.festo.com

P... – Pneumatic energy throughfeed

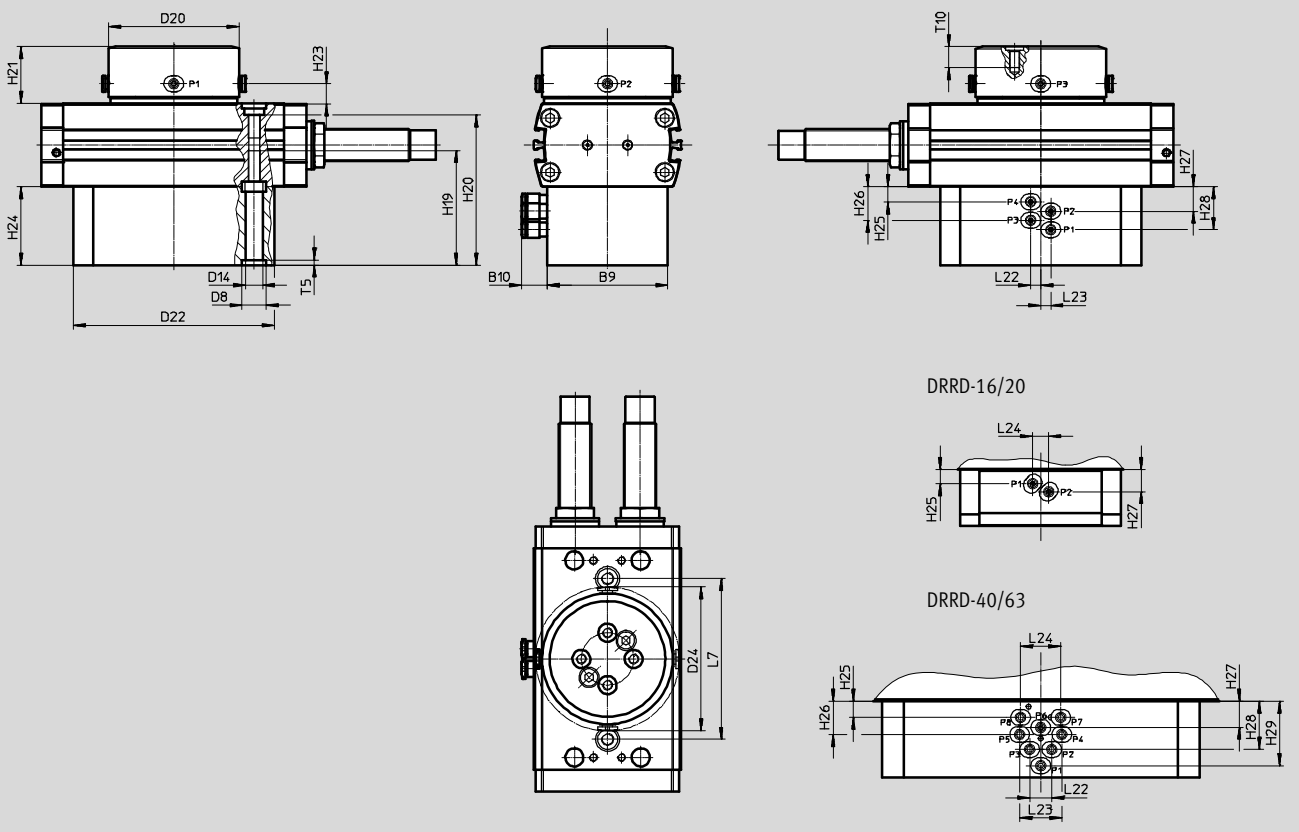

Size	B9	B10	D8 Ø H7	D14 Ø	D20 Ø	D22 Ø	D24 Ø	H19	H20	H21	H23	H24
16	52	13.4	9	6	54	82	70	43.1	56.4	16.6	7.6	28.1
20	58	13.4	9	6	54	82	70	43	59.3	17.6	8.6	28
25	60	12.8	12	6.5	64	100	71.6	57	74.7	28.3	9.8	40
32	70	12.8	15	8.5	64	120	71.6	62	82.4	31.5	12	40
35	80	12.8	15	8.5	64	138	71.6	61.6	95.5	30	10.5	40
40	80	13.4	15	11	89	158	96.9	70	97.4	21	10.5	38
50	80	13.4	15	11	89	190	96.9	68	107.4	24	11.5	38
63	80	13.4	25	13	89	210	96.9	78	127	29	13.5	38

Size	H25	H26	H27	H28	H29	L7	L22	L23	L24	T5	T10
						±0.02				+0.3/-0.2	
16	6.9	–	10.9	–	–	64	4	4	8	2.1	8.6
20	6.9	–	10.9	–	–	70	4	4	8	2.1	8.6
25	7.5	16.7	12.2	21.4	–	80	5	5	–	2.1	9.6
32	7.5	16.7	12.2	21.4	–	100	5	5	–	3.1	11.1
35	7.5	16.7	12.2	21.4	–	120	5	5	–	3.1	11.1
40	7	16.5	13.3	24	32	120	11	21	20	3.1	10.1
50	7	16.5	13.3	24	32	160	11	21	20	3.1	14.6
63	7	16.5	13.3	24	32	170	11	21	20	3.5	17.1

Twin-piston semi-rotary drives DRRD-16 ... 63

Technical data

Dimensions – Variants

Download CAD data → www.festo.com

P...E... – Pneumatic/electrical energy throughfeed

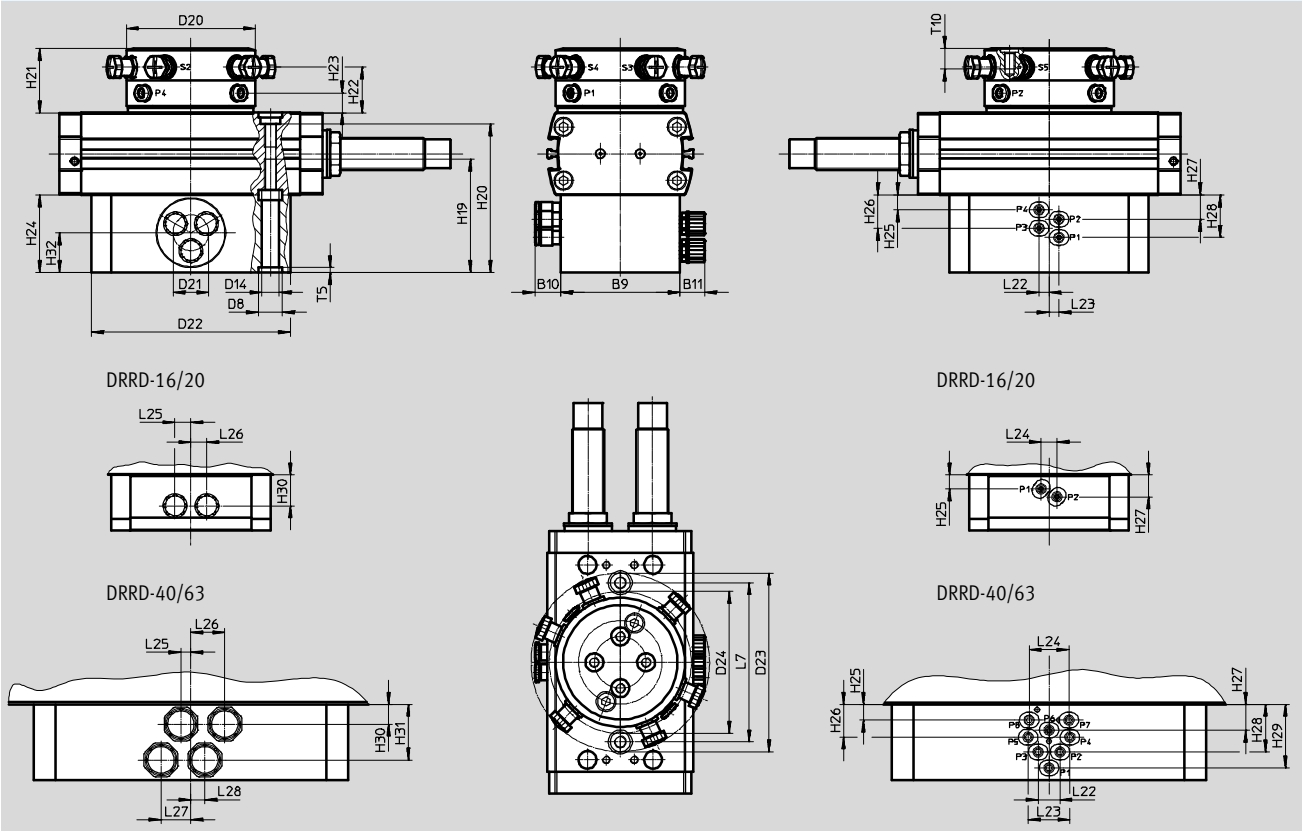

Size	B9	B10	B11	D8 Ø H7	D14 Ø	D20 Ø	D21 Ø	D22 Ø	D23 Ø	D24 Ø	H21	H22	H23	H24	H25	H26
16	52	13.4	8.5	9	6	54	16	82	71.1	70	28.6	21.1	7.6	28.1	6.9	–
20	58	13.4	8.5	9	6	54	16	82	71.1	70	29.6	22.1	8.6	28	6.9	–
25	60	12.8	12.4	12	6.5	64	18	100	89.8	71.6	32.3	22.8	9.8	40	7.5	16.7
32	70	12.8	12.4	15	8.5	64	18	120	89.8	71.6	34.5	25	12	40	7.5	16.7
35	80	12.8	12.4	15	8.5	64	18	138	89.8	71.6	33	23.5	10.5	40	7.5	16.7
40	80	13.4	24	15	11	89	–	158	138.5	96.9	40	28.5	10.5	38	7	16.5
50	80	13.4	24	15	11	89	–	190	138.5	96.9	44	32.5	11.5	38	7	16.5
63	80	13.4	24	25	13	89	–	210	138.5	96.9	48	36.5	13.5	38	7	16.5

Size	H27	H28	H29	H30	H31	H32	L7 ±0.02	L22	L23	L24	L25	L26	L27	L28	T5 +0.3/-0.2	T10
16	10.9	–	–	15.5	–	–	64	4	4	8	8	8	–	–	2.1	8.6
20	10.9	–	–	15.5	–	–	70	4	4	8	8	8	–	–	2.1	8.6
25	12.2	21.4	–	–	–	20	80	5	5	–	–	–	–	–	2.1	9.6
32	12.2	21.4	–	–	–	20	100	5	5	–	–	–	–	–	3.1	11.1
35	12.2	21.4	–	–	–	20	120	5	5	–	–	–	–	–	3.1	11.1
40	13.3	24	32	10	28	–	120	11	21	20	5	17	15	7	3.1	10.1 ¹⁾
50	13.3	24	32	10	28	–	160	11	21	20	5	17	15	7	3.1	14.6 ¹⁾
63	13.3	24	32	10	28	–	170	11	21	20	5	17	15	7	3.5	17.1 ¹⁾

1) The dimensions for variants DRRD-...-P8E8 are T10 = 8 mm

Twin-piston semi-rotary drives DRRD-16 ... 63

Technical data

Dimensions – Variants

Download CAD data → www.festo.com

Y12 – With external shock absorber

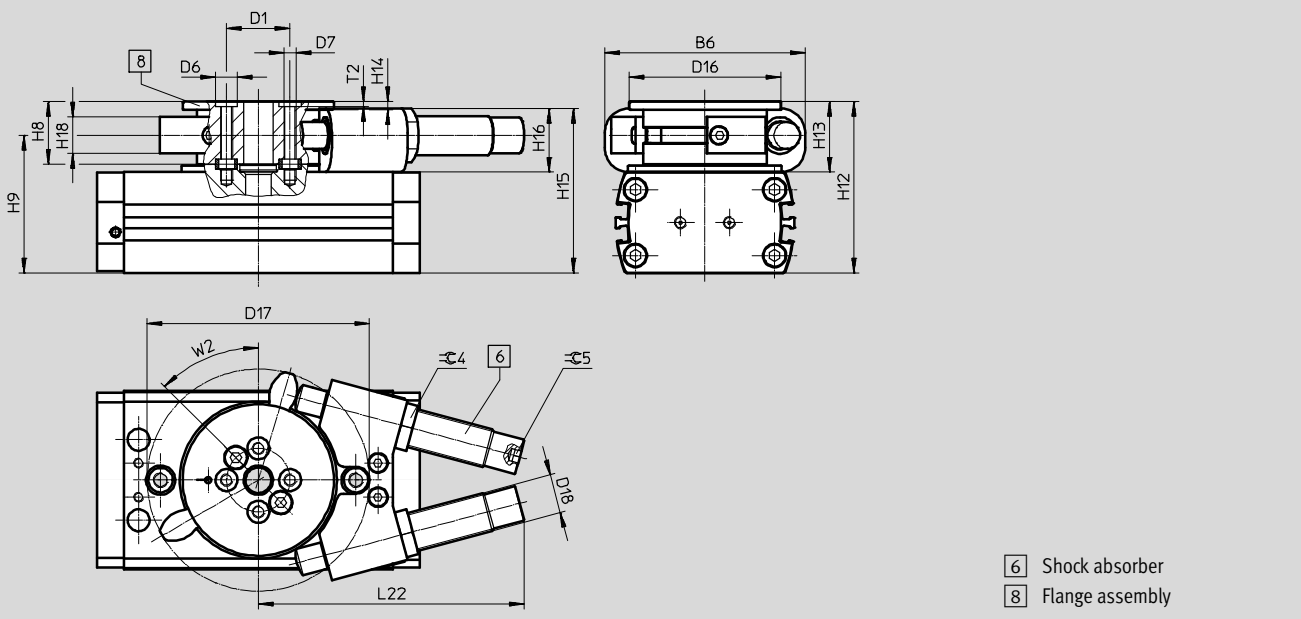

- 6 Shock absorber
- 8 Flange assembly

Size	B6	D1 ∅	D6 ∅ H7	D7	D16 ∅	D17	D18	H8	H9	H12
	±0.2	±0.025						±0.1		
16	58	21	7	M4	49	69.4	M10x1	17	43.1	52.6
20	75	24	7	M4	62	91	M12x1	25.6	51.2	65.2
25	82	26	9	M5	62	91	M16x1	25.6	56.5	70.3
32	120	40	9	M6	79	126.2	M22x1.5	31.5	68.5	87
35	133	45	9	M6	89	146.7	M22x1.5	34	83	101
40	133	45	9	M6	89	146.7	M22x1.5	34	88	106
50	152	54	12	M8	110	165.2	M26x1.5	42	101.5	125
63	186	63	15	M10	130	212.2	M30x1.5	52	129.5	159

Size	H13	H14	H15	H16	H18	L22	T2	W2	∠ 4	∠ 5
						max.	+0.1			
16	19.6	3.5	51	18	10	65.2	1.6	45°	13	3
20	29.2	3.5	59.5	23.5	15	85.3	1.6	45°	15	4
25	28.9	3.5	67.4	26	15	108.9	2.1	45°	19	5
32	37	4	85	35	22	149.7	2.1	45°	27	5
35	38	5	99	36	21	155.5	2.1	45°	27	5
40	38	5	104	36	21	155.5	2.1	45°	27	5
50	47	6	123	45	30	171.6	2.6	45°	32	6
63	59	6	155.5	55.5	36	228	3.1	45°	36	8

Twin-piston semi-rotary drives DRRD-16 ... 63

Technical data

Dimensions – Variants

Download CAD data → www.festo.com

PS1 – Intermediate position

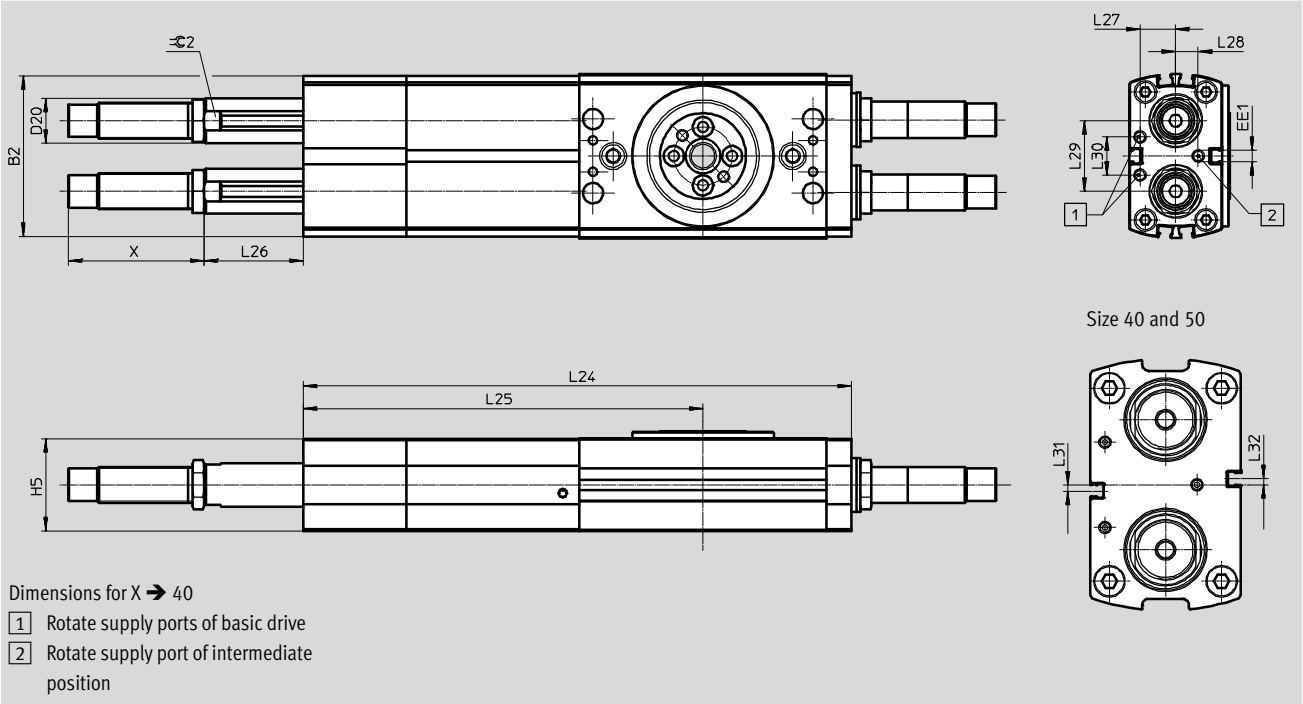

Dimensions for X → 40



- 1 Rotate supply ports of basic drive
- 2 Rotate supply port of intermediate position

Size	B2	H5	L24	L25	L26	L26	L27
					min.	max.	
16	56.2	32.6	193.1	140.6	0.3	21.5	12
20	63.4	35.6	205.1	151.1	4.5	28.4	14
25	71.5	41	244.1	178.1	14.1	44.2	15.9
32	92.6	49.6	320.1	238.6	3.4	43.5	19.5
35	104	62.2	343.1	254.1	14.8	54.5	25
40	111	67.2	392.1	277.6	9	54.1	27
50	139.7	77.2	542.6	391.6	12.3	86	30

Size	L28	L29	L30	L31	L32	D20	EE1	≈C 2
						∅		
16	6.2	21.65	15	-	-	14	M5	12
20	9	26.25	16	-	-	16	M5	14
25	10	31.45	17	-	-	20	M5	18
32	14	38.45	16	-	-	28	M5	24
35	18	49.6	18	-	-	32	M5	27
40	14	58	38	2.6	2.6	32	M5	27
50	20	78	44	5	5	36	G ¹ / ₈	32

Twin-piston semi-rotary drives DRRD-16 ... 63

Technical data

Ordering data – Stock items				
DRRD	Size	Swivel angle [°]	Part No.	Type
P – Elastic cushioning rings/pads at both ends				
	16	180	1577238	DRRD-16-180-FH-PA
	20		1395606	DRRD-20-180-FH-PA
	25		1359980	DRRD-25-180-FH-PA
	32		1578512	DRRD-32-180-FH-PA
	35		1526825	DRRD-35-180-FH-PA
	40		1503269	DRRD-40-180-FH-PA
Y9 – Linear shock absorber, self-adjusting at both ends				
	16	180	1644389	DRRD-16-180-FH-Y9A
	20		1427379	DRRD-20-180-FH-Y9A
	25		1360248	DRRD-25-180-FH-Y9A
	32		1578518	DRRD-32-180-FH-Y9A
	35		1547102	DRRD-35-180-FH-Y9A
	40		1526986	DRRD-40-180-FH-Y9A

Twin-piston semi-rotary drives DRRD-16 ... 63

Ordering data – Modular products

Ordering table												
Size	16	20	25	32	35	40	50	63	Condi- tions	Code	Entry code	
M Module no.	574399	574400	574401	574402	574403	574404	574405	574407				
Function	Semi-rotary drive									DRRD	DRRD	
Size	16	20	25	32	35	40	50	63		-...		
Nominal swivel angle	180°									-180	-180	
Output shaft	Flanged shaft, hollow									-FH	-FH	
O Energy throughfeed	None									-		
	Pneumatic, 2 channels		-							P2		
	Pneumatic, 2 channels; electric, 2 signals		-							P2E2		
	-		Pneumatic, 4 channels			-				P4		
	-		Pneumatic, 4 channels; electric, 6 signals			-				P4E6		
	-		-			Pneumatic, 8 channels				P8		
	-		-			Pneumatic, 8 channels; electric, 8 signals				P8E8		
M Cushioning	Elastic cushioning rings/pads at both ends							-		-P		
	Linear shock absorber, self-adjusting at both ends									-Y9		
	-		Linear shock absorber, self-adjusting at both ends, hard		-		Linear shock absorber, self-adjusting at both ends, hard			-Y10		
	Linear shock absorber, self-adjusting at both ends, external							1	5	-Y12		
Position sensing	For proximity sensor									A	A	
O EU certification	None											
	II 2GD									2	-EX4	
Intermediate position	Without							-				
	1 intermediate position							-		3	-PS1	
End-position locking	None											
	At both ends									4	5	-E1
Sensor mounting, external	Without											
	Mounting rail for proximity sensor									5	-R	
Version	Standard											
	Splash-proof design										-SG	
Operating instructions	With operating instructions											
	Without operating instructions										-DN	

- 1 Y12** Not with end-position locking E1 and splash-proof design SG
2 EX4 Not with end-position locking E1, energy throughfeed P2E2, P4E6, P8E8 and intermediate position PS1
3 PS1 Not with cushioning Y10 and in the case of cushioning P only for size 16 ... 32
4 E1 Not with sensor mounting R and splash-proof design SG
5 Y12, E1, R Not with energy throughfeed P2, P2E2, P4, P4E6, P8, P8E8

Transfer order code

	DRRD	-		-	180	-	FH	-		-	A	-		-		-		-	
--	-------------	---	--	---	------------	---	-----------	---	--	---	----------	---	--	---	--	---	--	---	--

Twin-piston semi-rotary drives DRRD

Accessories

Clamping unit DADL-EL

For size 16 ... 63

(order code: E1)

Stock items

Materials:

Housing: Anodised aluminium

Bearing: Plastic

RoHS-compliant

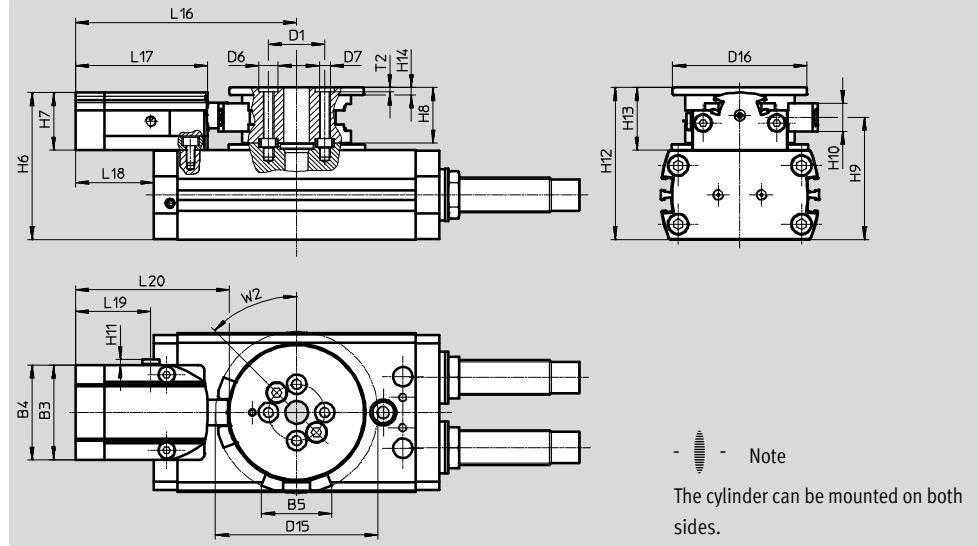

Dimensions and ordering data												
For size	B3	B4	B5	D1 ∅	D6 ∅	D7	D15 ∅	D16 ∅	H6	H7	H8	H9
	±0.2	±0.2		±0.025	H7					±0.15	±0.1	
16	37.6	38	26.9	21	7	M4	61.9	49	51	18	17	43.1
20	43.6	44	32.4	24	7	M4	74.9	62	62.5	26.5	25.6	51.2
25	43.6	44	32.4	26	9	M5	74.9	62	67.9	26.5	25.6	56.5
32	43.6	44	39.4	40	9	M6	95.4	79	79	26.7	31.5	68.5
35	57.6	58	50.2	45	9	M6	110.9	89	98	35	34	83
40	57.6	58	50.2	45	9	M6	110.9	89	103	35	34	88
50	71.4	72	59.6	54	12	M8	124.3	110	123	45	42	101.5
63	71.4	72	65.8	63	15	M10	148.5	130	149	49	52	129.5

For size	H10	H11	H12	H13	H14	L16	L17	L18	L19	L20	T2	W2
											+0.1	
16	9	2.5	52.6	19.6	3.5	83	50	30.5	34	58.3	1.6	45°
20	13	2.5	65.2	29.2	3.5	102.2	61.2	48.2	34.8	71.1	1.6	45°
25	13	2.5	70.3	28.9	3.5	102.2	61.2	36.2	34.8	71.1	2.1	45°
32	17	2.5	87	37	4	112.2	61.2	30.7	34.8	71.1	2.1	45°
35	14.8	2.5	101	38	5	132.5	70.6	43.5	42.6	85.4	2.1	45°
40	14.8	2.5	106	38	5	132.5	70.6	18	42.6	85.4	2.1	45°
50	19	4.6	125	47	6	151	81	0	46	98	2.6	45°
63	22	4.6	159	59	6	163	81	-29.5	46	99.5	3.1	45°

For size	Pneumatic connection	Operating pressure [bar]	Position sensing	Adjustable swivel angle [°]	Weight [g]	Part No.	Type
16	M5	5 ... 8	For proximity sensor	60 ... 200	166	1692770	DADL-EL-Q11-16
20					382	1579786	DADL-EL-Q11-20
25					370	1568183	DADL-EL-Q11-25
32					600	1631139	DADL-EL-Q11-32
35					900	1544900	DADL-EL-Q11-35/40
40					900	1544900	DADL-EL-Q11-35/40
50	G ¹ / ₈			62 ... 200	1610	1796637	DADL-EL-Q11-50
63					2380	1941568	DADL-EL-Q11-63

Twin-piston semi-rotary drives DRRD

Accessories

Sensing kit DASI-...-KT

For size 16 ... 63

(order code: R)

Stock items

Material:

Anodised aluminum

RoHS-compliant

For sensing the piston position using inductive proximity sensors SIES

→ 58

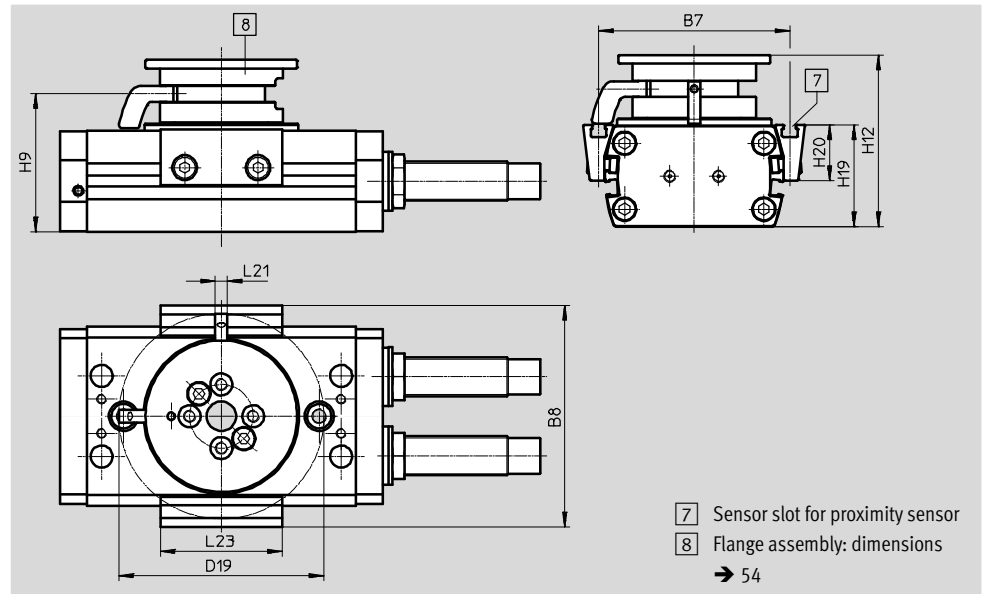





Dimensions and ordering data						
For size	B7	B8	D19 ∅	H9	H12	H19
16	64.4	76.1	70.9	43.1	52.6	33.5
20	74	85.7	84	51.2	65.2	36.4
25	78.2	90.7	84	56.5	70.3	41.8
32	100	113.5	107.5	68.5	87	50.5
35	116	132.9	125.2	83	101	63.5
40	118	135.8	125.2	88	106	68.5
50	136	155.3	146.6	101.5	125	79.1
63	163	185.3	173.9	129.5	159	101

For size	H20 ±0.1	L21	L23	Weight [g]	Part No.	Type ¹⁾
16	18.5	5	50	110	1693008	DASI-Q11-16-A-KT
20	20.2	5	50	192	1580899	DASI-Q11-20-A-KT
25	22.8	5	50	192	1568461	DASI-Q11-25-A-KT
32	26.5	7	50	366	1632097	DASI-Q11-32-A-KT
35	33.1	7	50	485	1551144	DASI-Q11-35-A-KT
40	35.5	7	50	485	1550027	DASI-Q11-40-A-KT
50	43	7	50	810	1797135	DASI-Q11-50-A-KT
63	55	7	50	1390	1946877	DASI-Q11-63-A-KT

1) ATEX-compliant

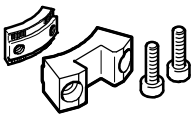
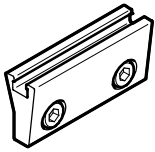
Twin-piston semi-rotary drives DRRD

Accessories

Ordering data ³⁾						
	For size	Description	Weight [g]	Part No.	Type	PU ¹⁾
Clamping component DADL-EC						
	16	For securing an intermediate position in combination with the clamping unit DADL-EL	18	1692496	DADL-EC-Q11-16	1
	20, 25		36	1435411	DADL-EC-Q11-20/25	
	32		67	1631170	DADL-EC-Q11-32	
	35, 40		98	1535091	DADL-EC-Q11-35/40	
	50		140	1796626	DADL-EC-Q11-50	
	63		220	1941355	DADL-EC-Q11-63	
	Sensor bracket DASI-...-SR⁴⁾					
	16	Additional sensing option in combination with the sensing kit DASI-...-KT	28	1692983	DASI-Q11-16-A-SR	2
	20		32	1581420	DASI-Q11-20-A-SR	
	25		32	1568451	DASI-Q11-25-A-SR	
	32		42	1631997	DASI-Q11-32-A-SR	
	35		62	1550870	DASI-Q11-35-A-SR	
	40		62	1548054	DASI-Q11-40-A-SR	
	50		75	1797071	DASI-Q11-50-A-SR	
	63		110	1971563	DASI-Q11-63-A-SR	
Switch lug DASI-...-SL⁴⁾						
	16	Additional sensing option in combination with the sensing kit DASI-...-KT	2.5	1692969	DASI-Q11-16-A-SL	1
	20, 25		4	1568436	DASI-Q11-20/25-A-SL	
	32		6	1631824	DASI-Q11-32-A-SL	
	35, 40		8	1548155	DASI-Q11-35/40-A-SL	
	50		10	1797021	DASI-Q11-50-A-SL	
	63		15	1971550	DASI-Q11-63-A-SL	
Shock absorber DYSC⁴⁾						
	12	<ul style="list-style-type: none"> • Self-adjusting shock absorber • Included in the scope of delivery for semi-rotary drive DRRD-...-Y12 	9	548011	DYSC-5-5-Y1F	1
	16		17	548012	DYSC-7-5-Y1F	
	20		36	548013	DYSC-8-8-Y1F	
	25		81	548014	DYSC-12-12-Y1F	
	32, 35, 40		210	553593	DYSC-16-18-Y1F	
	50		370	2479149	DYSC-20-18-Y1F	
	63		575	2480234	DYSC-25-25-Y1F	
Centring sleeve ZBH²⁾⁴⁾						
	8, 10	For centring the semi-rotary drive	1	186717	ZBH-7	10
	12, 16, 20		1	150927	ZBH-9	
	25		1	189653	ZBH-12	
	32 ... 50		3	191409	ZBH-15	
	63		5	8023856	ZBH-25	
	8, 10, 12	For centring attachments on the flanged shaft	1	189652	ZBH-5	
	16, 20		1	186717	ZBH-7	
	25 ... 40		1	150927	ZBH-9	
	50		1	189653	ZBH-12	
	63		3	191409	ZBH-15	

1) Packaging unit

2) 2 included in the scope of delivery for the semi-rotary drive or attachments



3) Stock items

4) ATEX-compliant

Twin-piston semi-rotary drives DRRD

Accessories

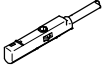
Proximity sensors for size 8 ... 12

Ordering data – Proximity sensor for C-slot, magneto-resistive						Technical data → Internet: smt
	Type of mounting	Switching output	Electrical connection, connection direction	Cable length [m]	Part No.	Type
Normally open						
	Insertable in the slot from above	PNP	Cable, 3-wire, in-line	2.5	551373	SMT-10M-PS-24V-E-2,5-L-OE
			Plug M8x1, 3-pin, in-line	0.3	551375	SMT-10M-PS-24V-E-0,3-L-M8D
			Plug M8x1, 3-pin, lateral	0.3	551376	SMT-10M-PS-24V-E-0,3-Q-M8D
	Insertable in the slot lengthwise	PNP	Cable, 3-wire, lateral	2.5	547862	SMT-10G-PS-24V-E-2,5Q-OE
			Plug M8x1, 3-pin, lateral	0.3	547863	SMT-10G-PS-24V-E-0,3Q-M8D

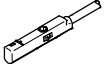

Ordering data – Proximity sensors for C-slot, magnetic reed

Ordering data – Proximity sensors for C-slot, magnetic reed						Technical data → Internet: sme
	Type of mounting	Switching output	Electrical connection, connection direction	Cable length [m]	Part No.	Type
Normally open						
	Insertable in the slot from above	With contact	Plug M8x1, 3-pin, in-line	0.3	551367	SME-10M-DS-24V-E-0,3-L-M8D
			Cable, 3-wire, in-line	2.5	551365	SME-10M-DS-24V-E-2,5-L-OE
			Cable, 2-wire, in-line	2.5	551369	SME-10M-ZS-24V-E-2,5-L-OE

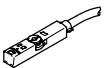
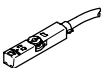
Proximity sensors for size 16 ... 63

Ordering data – Proximity sensors for T-slot, magneto-resistive						Technical data → Internet: smt
	Type of mounting	Switching output	Electrical connection	Cable length [m]	Part No.	Type
Normally open						
	Insertable in the slot from above, flush with the cylinder profile, short design	PNP	Cable, 3-wire	2.5	574335	SMT-8M-A-PS-24V-E-2,5-OE
			Plug M8x1, 3-pin	0.3	574334	SMT-8M-A-PS-24V-E-0,3-M8D
			Plug M12x1, 3-pin	0.3	574337	SMT-8M-A-PS-24V-E-0,3-M12
		NPN	Cable, 3-wire	2.5	574338	SMT-8M-A-NS-24V-E-2,5-OE
			Plug M8x1, 3-pin	0.3	574339	SMT-8M-A-NS-24V-E-0,3-M8D
N/C contact						
	Insertable in the slot from above, flush with the cylinder profile, short design	PNP	Cable, 3-wire	7.5	574340	SMT-8M-A-PO-24V-E-7,5-OE

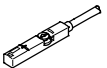
Ordering data – Proximity sensors for T-slot, magnetic reed



Ordering data – Proximity sensors for T-slot, magnetic reed						Technical data → Internet: sme
	Type of mounting	Switching output	Electrical connection	Cable length [m]	Part No.	Type
Normally open						
	Insertable in the slot from above, flush with the cylinder profile	Contacting	Cable, 3-wire	2.5	543862	SME-8M-DS-24V-K-2,5-OE
				5.0	543863	SME-8M-DS-24V-K-5,0-OE
			Cable, 2-wire	2.5	543872	SME-8M-ZS-24V-K-2,5-OE
			Plug M8x1, 3-pin	0.3	543861	SME-8M-DS-24V-K-0,3-M8D
	Insertable in the slot lengthwise, flush with the cylinder profile	Contacting	Cable, 3-wire	2.5	150855	SME-8-K-LED-24
			Plug M8x1, 3-pin	0.3	150857	SME-8-S-LED-24

Twin-piston semi-rotary drives DRRD

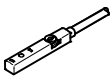
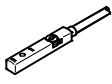
Accessories

Ordering data – Proximity sensors for T-slot, inductive					Technical data → Internet: sies	
	Type of mounting	Switching output	Electrical connection	Cable length [m]	Part No.	Type
Normally open						
	Insertable in the slot from above, flush with the cylinder profile	PNP	Cable, 3-wire	7.5	551386	SIES-8M-PS-24V-K-7,5-OE
			Plug M8x1, 3-pin	0.3	551387	SIES-8M-PS-24V-K-0,3-M8D
		NPN	Cable, 3-wire	7.5	551396	SIES-8M-NS-24V-K-7,5-OE
			Plug M8x1, 3-pin	0.3	551397	SIES-8M-NS-24V-K-0,3-M8D
N/C contact						
	Insertable in the slot from above, flush with the cylinder profile	PNP	Cable, 3-wire	7.5	551391	SIES-8M-PO-24V-K-7,5-OE
			Plug M8x1, 3-pin	0.3	551392	SIES-8M-PO-24V-K-0,3-M8D
		NPN	Cable, 3-wire	7.5	551401	SIES-8M-NO-24V-K-7,5-OE
			Plug M8x1, 3-pin	0.3	551402	SIES-8M-NO-24V-K-0,3-M8D

 **Note**
 The inductive proximity sensors SIES can only be used in combination with the sensing kit DASI-...-KT.

Ordering data – Connecting cables				Technical data → Internet: nebu	
	Electrical connection, left	Electrical connection, right	Cable length [m]	Part No.	Type
	Straight socket, M8x1, 3-pin	Cable, open end, 3-wire	2.5	541333	NEBU-M8G3-K-2.5-LE3
			5	541334	NEBU-M8G3-K-5-LE3
	Angled socket, M8x1, 3-pin	Cable, open end, 3-wire	2.5	541338	NEBU-M8W3-K-2.5-LE3
			5	541341	NEBU-M8W3-K-5-LE3

Twin-piston semi-rotary drives DRRD

Accessories

Wiring of the proximity sensor only in combination with the energy throughfeed

Size 16/20

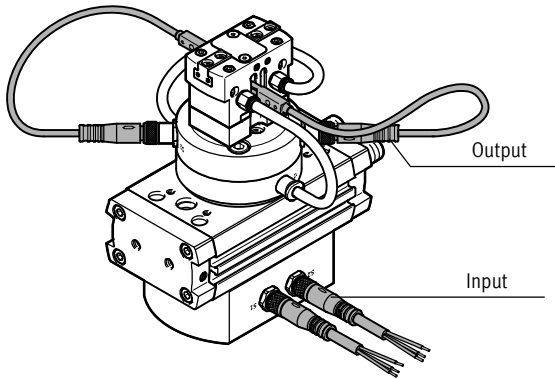

Size 25/32/35

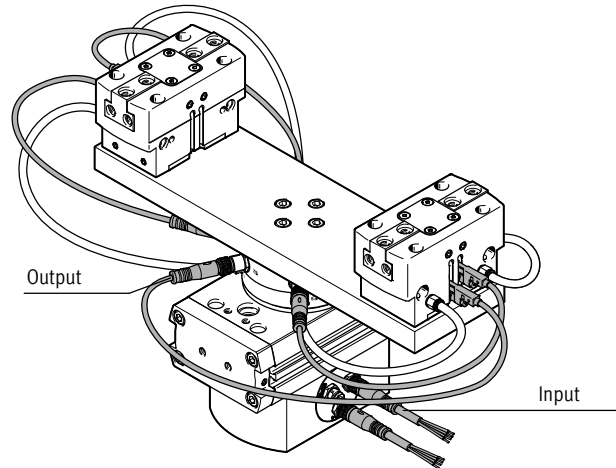

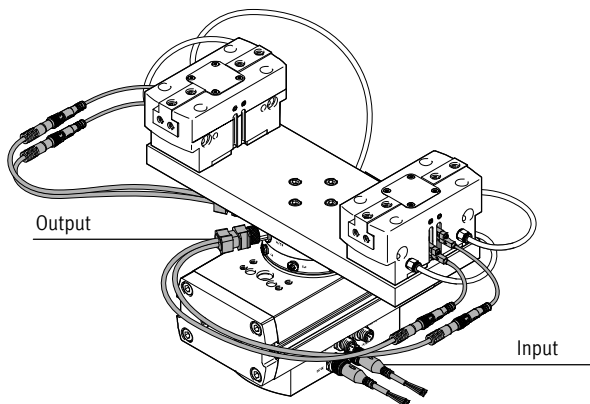

Size 40/50/63



 Note

Proximity sensors with plug connectors must be used for attachments (e.g. grippers) at the output. On sizes 16 ... 35 these can be connected directly to the energy

throughfeed module. On sizes 40 ... 63, the proximity sensors must be connected to the energy throughfeed module using a push-in T-connector.

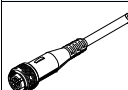
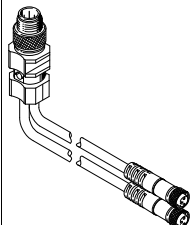
Ordering data				Technical data → Internet: nebu	
	Electrical connection, left	Electrical connection, right	Cable length [m]	Part No.	Type
Input – Connecting cable					
Size 16/20					
	Straight socket, M8x1, 3-pin	Cable, open end, 3-wire	2.5	541333	NEBU-M8G3-K-2.5-LE3
	Straight socket, M8x1, 3-pin	Cable, open end, 3-wire	5	541334	NEBU-M8G3-K-5-LE3
Size 25/32/35					
	Straight socket, M8x1, 4-pin	Cable, open end, 4-wire	2.5	541342	NEBU-M8G4-K-2.5-LE4
	Straight socket, M8x1, 4-pin	Cable, open end, 4-wire	5	541343	NEBU-M8G4-K-5-LE4
Size 40/50/63					
	Straight socket, M12x1, 5-pin	Cable, open end, 4-wire	2.5	550326	NEBU-M12G5-K-2.5-LE4
	Straight socket, M12x1, 5-pin	Cable, open end, 4-wire	5	541328	NEBU-M12G5-K-5-LE4
Output – Push-in T-connector					
Size 40/50/63					
	Straight plug, M12x1, 4-pin	2x straight sockets, M8x1, 3-pin	0.5	18685	KM12-DUO-M8-GDGD
	Straight plug, M12x1, 4-pin	2x angled sockets, M8x1, 3-pin	0.5	18687	KM12-DUO-M8-WDWD

Twin-piston semi-rotary drives DRRD

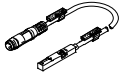

Accessories

Proximity sensors for size 16 ... 63

Ordering data – Positioning transmitter for T-slot				Technical data → Internet: smat	
Size	Analogue output [V]	Electrical connection	Cable length [m]	Part No.	Type
	0 ... 10	M8 plug, 4-pin, rotatable thread	0.3	553744	SMAT-8M-U-E-0,3-M8D

 **Note**
Mode of operation:
 The position transmitter continuously senses the position of the piston. It has an analogue output with an output signal in proportion to the piston position.

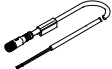
For size	Position measuring range approx. [°]
16	151
20	120
25	183
32	159
35	185
40	132
50	82
63	64

Ordering data – Connecting cable				Technical data → Internet: nebu	
	Electrical connection, left	Electrical connection, right	Cable length [m]	Part No.	Type
	Straight socket, M8x1, 4-pin	Cable, open end, 4-wire	2.5	541342	NEBU-M8G4-K-2.5-LE4
			5	541343	NEBU-M8G4-K-5-LE4
	Angled socket, M8x1, 4-pin	Cable, open end, 4-wire	2.5	541344	NEBU-M8W4-K-2.5-LE4
			5	541345	NEBU-M8W4-K-5-LE4

Twin-piston semi-rotary drives DRRD

Accessories

Setting the swivel speed

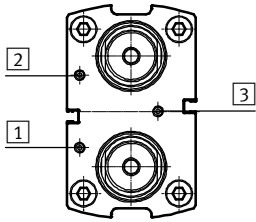

Semi-rotary module and intermediate-position module must only be operated with controlled air flow. The throttles should be connected as close as possible to the semi-rotary drive (e.g. one-way flow control valve GRLA-...) → 61.



In the event of pressure failure, the payload may hit an end position in an uncontrolled manner. In order to prevent this, piloted non-return valves HGL or an air pressure reservoir VZS are recommended.

The following movements are set via supply ports **1** and **2**.

End position → intermediate position
Both directions can be adjusted separately from each other.

The following movement is set via supply port **3**.

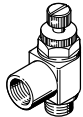
Intermediate position → end position
Both directions are set simultaneously.

Ordering data						
	For size	Description	Weight [g]	Part No.	Type	PU ¹⁾
One-way flow control valve GRLA						
	16, 20, 25	• To set the swivel speed	14	197576	GRLA-M5-QS-3-RS-D	1
	32, 35, 40		14	197577	GRLA-M5-QS-4-RS-D	
			30	151169	GRLA-1/8-RS-B	
			59	151175	GRLA-1/4-RS-B	
	63		97	151178	GRLA-3/8-B	

1) Packaging unit quantity

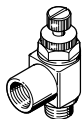
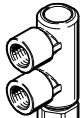
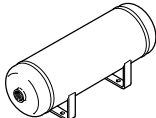
Ordering data – Accessories in combination with the intermediate position module (PS1)						
	For size	Description	Weight [g]	Part No.	Type	PU ¹⁾
One-way flow control valve GRLA						
	16 ²⁾ , 20, 25,	• To set the swivel speed from the intermediate position	14	197576	GRLA-M5-QS-3-RS-D	1
	32, 35, 40		14	197577	GRLA-M5-QS-4-RS-D	
	50		30	151169	GRLA-1/8-RS-B	
Non-return valve HGL						
	20, 25, 32, 35,	• For cushioning the payload in the event of a loss of compressed air	21	530029	HGL-M5-B	1
	40		21	530038	HGL-M5-QS-4	
	50		26	543253	HGL-1/8-1/8-B	
			21	530030	HGL-1/8-B	
Air pressure reservoir VZS						
	16, 20, 25, 32, 35, 40, 50	• For cushioning the payload in the event of a loss of compressed air	8600	192161	VZS-20-B	1

1) Packaging unit quantity

2) Strongly recommended for this size

Twin-piston semi-rotary drives DRRD

Accessories

FESTO

Adapter kit
DHAA, HAPG

Materials:
Wrought aluminium alloy
Free of copper and PTFE
RoHS-compliant

 Note
The kit includes the individual mounting interface as well as the necessary mounting material.

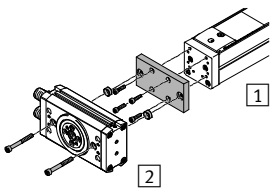
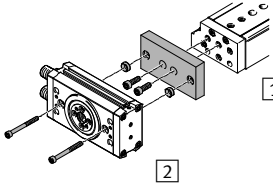
Permissible drive/drive combinations with adapter kit			Download CAD data → www.festo.com			
Combination	1 Drive	2 Drive	Adapter kit			Required quantity
	Size	Size	CRC ¹⁾	Part No.	Type	
	DGEA	DRRD	DHAA			1
	18	16	2	1675259	DHAA-D-E2-18-Q11-16	
	18, 25	20		1679833	DHAA-D-E2-18/25-Q11-20	
	25	25		1696421	DHAA-D-E2-25-Q11-25	
	25	32		1702297	DHAA-D-E2-25-Q11-32	
	40	32		1706071	DHAA-D-E2-40-Q11-32	
	40	35		1706503	DHAA-D-E2-40-Q11-35	
	40	40		1706822	DHAA-D-E2-40-Q11-40	
	DGEA	DRRD-...-E		DHAA		
	18	16	2	2328624	DHAA-D-E2-18-Q11-16-E	
	18, 25	20		2328779	DHAA-D-E2-18/25-Q11-20-E	
	25	25		2328793	DHAA-D-E2-25-Q11-25-E	
	25	32		2328805	DHAA-D-E2-25-Q11-32-E	
	40	32		2328816	DHAA-D-E2-40-Q11-32-E	
	40	35		2328827	DHAA-D-E2-40-Q11-35-E	
	40	40		2328838	DHAA-D-E2-40-Q11-40-E	
	DGSL	DRRD		DHAA		
	4	8	2	2767489	DHAA-D-G6-4-Q11-8	
	6	8		2762930	DHAA-D-G6-6-Q11-8	
	8, 10	10		2737394	DHAA-D-G6-8/10-Q11-10	
	12, 16	10		2737247	DHAA-D-G6-12/16-Q11-10	
	8, 10	12		2736429	DHAA-D-G6-8/10-Q11-12	
	12	12		2782718	DHAA-D-G6-12-Q11-12	
	16	12		2734418	DHAA-D-G6-16-Q11-12	
	20	16		1917841	DHAA-D-G6-20-Q11-16	
	20, 25	20		1916912	DHAA-D-G6-20/25-Q11-20	
	25	25		1707360	DHAA-D-G6-25-Q11-25	
	DGSL	DRRD-...-E	DHAA			1
	20	16	2	2332271	DHAA-D-G6-20-Q11-16-E	
	20, 25	20		2332452	DHAA-D-G6-20/25-Q11-20-E	
	25	25		2332584	DHAA-D-G6-25-Q11-25-E	

- 1) Corrosion resistance class CRC 2 to Festo standard FN 940070
Moderate corrosion stress. Indoor applications in which condensation may occur. External visible parts with primarily decorative requirements for the surface and which are in direct contact with the ambient atmosphere typical for industrial applications.
- 2) Packaging unit quantity

Twin-piston semi-rotary drives DRRD

Accessories

FESTO

Adapter kit
DHAA, HAPG

Materials:
Wrought aluminium alloy
Free of copper and PTFE
RoHS-compliant

 Note
The kit includes the individual mounting interface as well as the necessary mounting material.

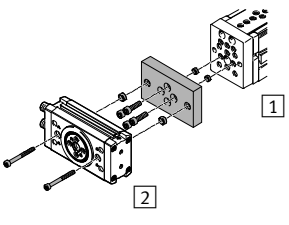
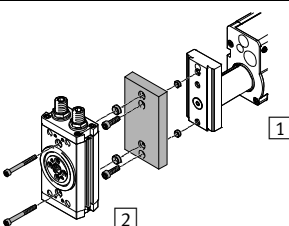
Permissible drive/drive combinations with adapter kit				Download CAD data → www.festo.com			
Combination	1	2	Adapter kit				
	Drive	Drive	CRC ¹⁾	Part No.	Type	Required quantity	
EGSL/DRRD	EGSL	DRRD	DHAA				
	35	8	2	2730033	DHAA-D-E8-35-Q11-8	1	
	35	10		2729506	DHAA-D-E8-35-Q11-10		
	45	10		2728486	DHAA-D-E8-45-Q11-10		
	35	12		2719384	DHAA-D-E8-35-Q11-12		
	45, 55	12		2715152	DHAA-D-E8-45/55-Q11-12		
	55	16		1926914	DHAA-D-E8-55-Q11-16		
	75	16		1928306	DHAA-D-E8-75-Q11-16		
	75	20		1930038	DHAA-D-E8-75-Q11-20		
	EGSL	DRRD-...-E		2	DHAA		
	55	16	2279410		DHAA-D-E8-55-Q11-16-E	1	
	75	16	2279453		DHAA-D-E8-75-Q11-16-E		
	75	20	2279473		DHAA-D-E8-75-Q11-20-E		
	HMP/DRRD	HMP	DRRD	DHAA			
	16	16	2	1910123	DHAA-D-H2-16-Q11-16	1	
	20	16		1910361	DHAA-D-H2-20-Q11-16		
	16	20		1910095	DHAA-D-H2-16-Q11-20		
	20, 25	20		1909616	DHAA-D-H2-20/25-Q11-20		
	20, 25	25		1708627	DHAA-D-H2-20/25-Q11-25		
	32	25		1794755	DHAA-D-H2-32-Q11-25		
	25	32		1909212	DHAA-D-H2-25-Q11-32		
	32	32		1909181	DHAA-D-H2-32-Q11-32		
	32	35		1909185	DHAA-D-H2-32-Q11-35		
	HMP	DRRD-...-E	2	DHAA			
	16	16		2333525	DHAA-D-H2-16-Q11-16-E	1	
	20	16		2333544	DHAA-D-H2-20-Q11-16-E		
	16	20		2333585	DHAA-D-H2-16-Q11-20-E		
20, 25	20	2333638		DHAA-D-H2-20/25-Q11-20-E			
20, 25	25	2333669	DHAA-D-H2-20/25-Q11-25-E				
32	25	2333711	DHAA-D-H2-32-Q11-25-E				
25	32	2333725	DHAA-D-H2-25-Q11-32-E				
32	32	2333757	DHAA-D-H2-32-Q11-32-E				
32	35	2334427	DHAA-D-H2-32-Q11-35-E				

- Corrosion resistance class CRC 2 to Festo standard FN 940070
Moderate corrosion stress. Indoor applications in which condensation may occur. External visible parts with primarily decorative requirements for the surface and which are in direct contact with the ambient atmosphere typical for industrial applications.
- Packaging unit quantity
- The centring sleeves for attaching to the adapter kit HAPG-72-B are not required.

Twin-piston semi-rotary drives DRRD

Accessories

FESTO

Adapter kit
DHAA, HAPG

Materials:
Wrought aluminium alloy
Free of copper and PTFE
RoHS-compliant



Note

The kit includes the individual mounting interface as well as the necessary mounting material.

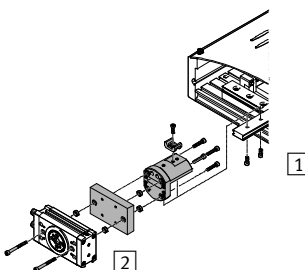
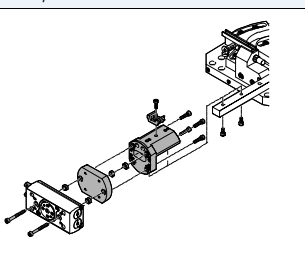
Permissible drive/drive combinations with adapter kit			Download CAD data → www.festo.com			
Combination	1 Drive	2 Drive	Adapter kit			Required quantity
	Size	Size	CRC ¹⁾	Part No.	Type	
	HSP	DRRD	DHAA			1
	12	8	2	2786084	DHAA-D-H4-12-Q11-8	
			–	540881	HAPG-70-B	
	16	10	2	2785801	DHAA-D-H4/H5-12/16-Q11-10	
			–	540882	HAPG-71-B	
	16	12	2	2784113	DHAA-D-H4/H5-16/25-Q11-12	
			–	540882	HAPG-71-B	
	25	12	2	2784113	DHAA-D-H4/H5-16/25-Q11-12	
			–	540883	HAPG-72-B ³⁾	
	25	16	2	1919910	DHAA-D-H4-25-Q11-16	
		–	540883	HAPG-72-B ³⁾		
HSP	DRRD-...-E	DHAA			1	
25	16	2	2284940	DHAA-D-H4-25-Q11-16-E		
		–	540883	HAPG-72-B ³⁾		
	HSW	DRRD	DHAA			1
	10	8	2	2789655	DHAA-D-H5-10-Q11-8	
			–	540249	HAPG-69	
	12	8	2	2788114	DHAA-D-H5-12-Q11-8	
			–	540882	HAPG-71-B	
	12	10	2	2785801	DHAA-D-H4/H5-12/16-Q11-10	
			–	540882	HAPG-71-B	
	16	10	2	2785801	DHAA-D-H4/H5-12/16-Q11-10	
			–	540882	HAPG-71-B	
	16	12	2	2784113	DHAA-D-H4/H5-16/25-Q11-12	
		–	540882	HAPG-71-B		

1) Corrosion resistance class CRC 2 to Festo standard FN 940070

Moderate corrosion stress. Indoor applications in which condensation may occur. External visible parts with primarily decorative requirements for the surface and which are in direct contact with the ambient atmosphere typical for industrial applications.

2) Packaging unit quantity

3) The centring sleeves for attaching to the adapter kit HAPG-72-B are not required.