

Positioning axes DMES

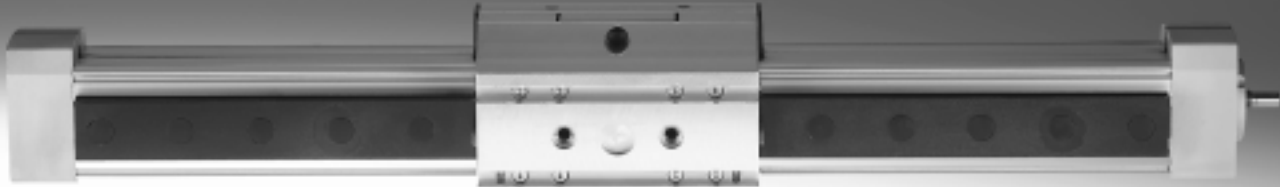

Positioning axes DMES

Key features

At a glance		
General	Properties	Range of applications
<p>DMES positioning axes are mechanical linear drives that are specially designed for movements involving high forces.</p> <p>The mechanical interfaces are compatible with the spindle axis DGE-SP.</p>	<ul style="list-style-type: none"> • High mechanical torques • High feed forces up to 3,000 N • Self-retarding lead-screw spindle • Compact dimensions • Cost optimised 	<ul style="list-style-type: none"> • Alternatively: <ul style="list-style-type: none"> – without guide – with plain-bearing guide GF – with recirculating ball bearing guide KF • For format adjustment: <ul style="list-style-type: none"> – in printing, paper and foil wrapping machines – in packaging machines – in feed technology

Application examples

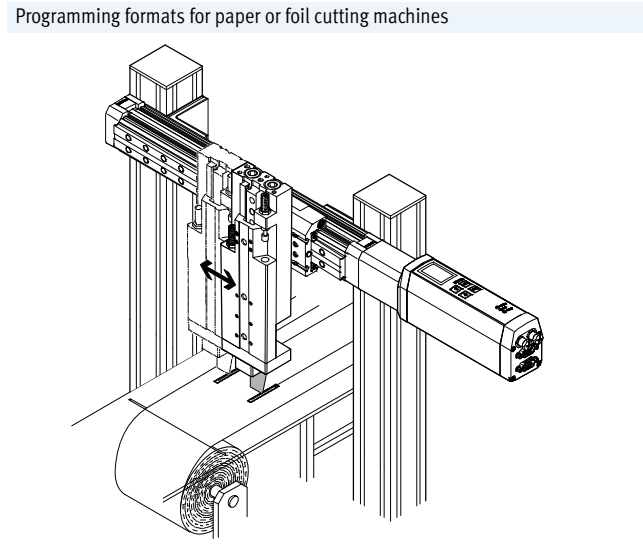
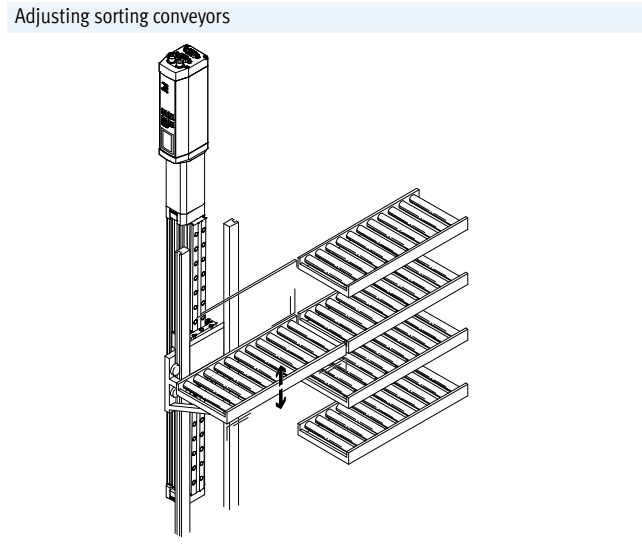

The technology in detail

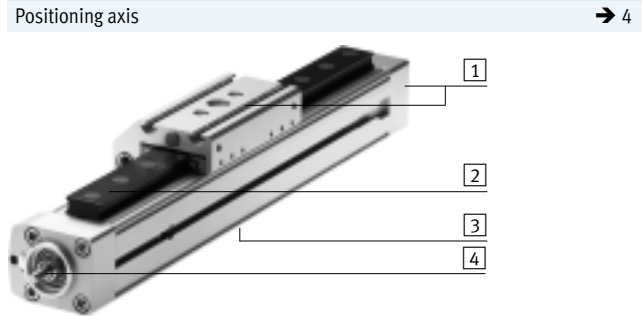

- 1 Mechanical interfaces are identical to spindle axes DGE-...-SP
- 2 Choice of two guide variants:
 - GF: Plain-bearing guide
 - KF: Recirculating ball bearing guide
- 3 Slot for proximity sensor
- 4 Lead-screw spindle, for use with high forces

The lead-screw spindle is self-retarding, which means that slow movements cannot be excluded in the event of vibration. The entire system with intelligent motor unit MTR-DCI is self-locking.

A range of specially adapted complete solutions is available for the positioning axes DMES and the motors. Two motor interfaces are available:

- Axial motor interface
- Parallel motor interface

Positioning axes DMES

Key features

Wide choice of variants

Basic design DMES, without guide



- For connection to an existing guide
- For small loads

Plain-bearing guide DMES-GF



- With standard slide (GK) or extended slide (GV)
- For medium loads
- For medium guide precision

Recirculating ball bearing guide DMES-KF



- With standard slide (GK) or extended slide (GV)
- For higher loads
- For high guide precision

Protected version DMES-GA



- With standard slide (GK)
- With plain or recirculating ball bearing guide as an option
- Guide and slide are fitted with a cover to protect against the ingress of particles from above and from the side

Guide characteristics

The specifications shown in the table are maximum values.

The precise values for each of the variants can be found in the relevant technical data in the catalogue.

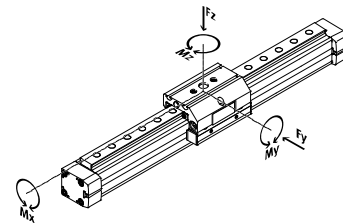
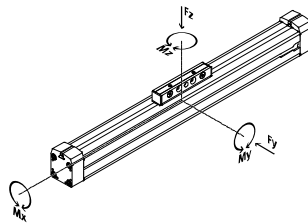

	Size	Working stroke [mm]	Speed [m/s]	Repetition accuracy [mm]	Feed force [N]	Forces and torques					→ Page/ Internet
						Fy [N]	Fz [N]	Mx [Nm]	My [Nm]	Mz [Nm]	
Basic design DMES											
	18	50 ... 400	0.05	±0.05	240	36	80	0.4	2	0.7	6
	25	50 ... 700	0.05	±0.05	500	80	100	1.3	4	1.6	
	40	50 ... 1,200	0.05	±0.05	1,000	92	390	2.2	20	4.6	
	63	50 ... 1,800	0.05	±0.07	3,000	300	900	12	80	22	
Plain-bearing guide DMES-GF											
	18	50 ... 400	0.05	±0.05	240	930	930	7	45	45	20
	25	50 ... 700	0.05	±0.05	500	1,650	1,650	23	95	95	
	40	50 ... 1,200	0.05	±0.05	1,000	3,990	3,990	89	360	360	
	63	50 ... 1,800	0.05	±0.07	3,000	7,250	7,250	290	980	980	
Recirculating ball bearing guide DMES-KF											
	18	50 ... 400	0.05	±0.05	240	930	930	7	45	45	20
	25	50 ... 700	0.05	±0.05	500	3,080	3,080	45	170	170	
	40	50 ... 1,200	0.05	±0.05	1,000	7,300	7,300	170	660	660	
	63	50 ... 1,800	0.05	±0.07	3,000	13,900	14,050	580	1,820	1,820	

Positioning axes DMES, without guide

Peripherals overview

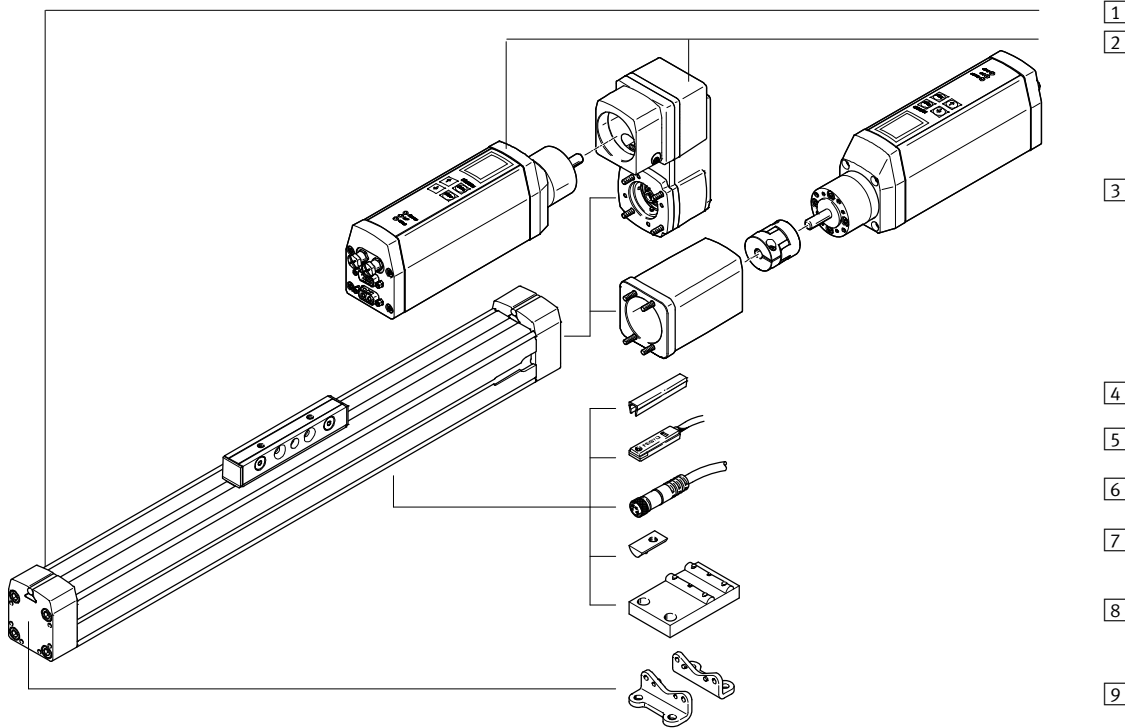

Variants and accessories		
Type/Order code	Brief description	→ Page/Internet
1 Positioning axis DMES	Electromechanical axis without guide	6
2 Intelligent servo unit and parallel kit U	Complete package for parallel motor attachment, comprising parallel kit and intelligent motor unit MTR-DCI	14
3 Intelligent servo unit and axial kit AX	Complete package for axial motor attachment, comprising axial kit and intelligent motor unit MTR-DCI	14
4 Slot cover B/S	For protecting against ingress of dirt	49
5 Proximity sensor SMT-8	For providing a proximity signal or safety sensing	48
6 Connecting cable KM8	For proximity sensor	48
7 Slot nut for mounting slot Y	For mounting attachments	49
8 Central support M	For mounting the axis	46
9 Foot mounting F	For mounting the axis (can only be attached to end cap, must be combined with central support)	46

-  - Note
 Servo, stepper motors and the corresponding mounting kits must be ordered separately → 42

Positioning axes DMES, without guide

Type code

DMES - 25 - 500 - AX : ZUB - 2Y 2M

Type

DMES	Positioning axis
------	------------------

Size

Stroke [mm]

Motor unit

AX	Intelligent servo unit and axial kit
U	Intelligent servo unit and parallel kit

Accessories

ZUB	Accessories supplied loose
-----	----------------------------

Slot cover

...S	Sensor slot
...B	Mounting slot

Slot nut

...Y	For mounting slot
------	-------------------

Central support

...M	Central support
------	-----------------

Foot mounting

...F	Foot mounting
------	---------------

Positioning axes DMES, without guide

Technical data

Function

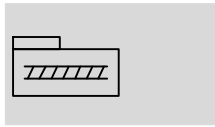

- - Size
18 ... 63
- - Stroke length
50 ... 1,800 mm

General technical data					
Size		18	25	40	63
Design		Electromechanical linear axis with lead-screw spindle			
Guide		None			
Assembly position		Any			
Working stroke	[mm]	50 ... 400	50 ... 700	50 ... 1,200	50 ... 1,800
Max. feed force F_x	[N]	240	500	1,000	3,000
Max. driving torque	[Nm]	0.3	0.9	3	14
Max. no-load driving torque ¹⁾	[Nm]	0.07	0.2	0.45	1.1
Max. radial force ²⁾	[N]	40	75	250	800
Max. speed	[m/s]	0.05			
Max. acceleration	[m/s ²]	2.5			
Repetition accuracy	[mm]	±0.05			±0.07
Positioning rigidity	[N/mm]	1,700	2,300	4,200	5,600
Duty cycle	[%]	100			
Reversing backlash ³⁾	[mm]	< 0.1			

- 1) Measured at a speed of 200 rpm.
- 2) On drive shaft
- 3) In new condition

Operating and environmental conditions		
Ambient temperature ¹⁾	[°C]	0 ... +50
Protection class		IP40

- 1) Note operating range of proximity sensors

Weights [kg]					
Size		18	25	40	63
Basic weight with 0 mm stroke ¹⁾		0.49	0.98	2.9	10.05
Additional weight per 100 mm stroke		0.2	0.36	0.74	1.97
Moving load		0.06	0.15	0.47	1.51

- 1) Without coupling housing

Positioning axes DMES, without guide

Technical data

Mass moment of inertia					
Size		18	25	40	63
J_0	[kg cm ²]	0.0028	0.0147	0.1824	1.7747
j_H per metre stroke	[kg cm ² /m]	0.0210	0.0980	0.8400	5.5600
j_L per kg working load	[kg cm ² /Kg]	0.0006	0.0023	0.0041	0.0091

The mass moment of inertia J_A of the entire axis is calculated as follows: $J_A = J_0 + j_H \times \text{working stroke [m]} + j_L \times m_{\text{working load [kg]}}$

Spindle					
Size		18	25	40	63
Diameter	[mm]	8	12	20	32
Pitch	[mm/rev.]	1.5	2.5	4	6

Materials

Sectional view

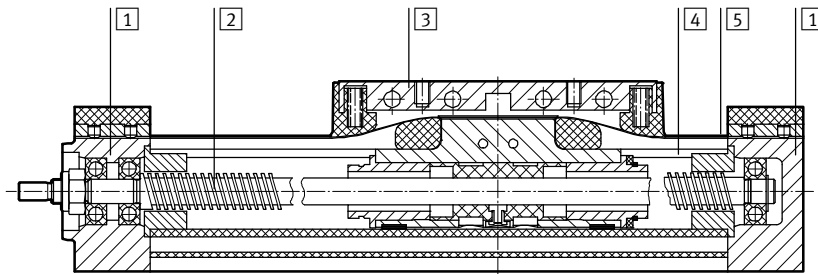

Positioning axis		
1	Cover	Wrought aluminium alloy, anodised
2	Spindle	Steel
3	Piston, driver	Wrought aluminium alloy, anodised
4	Profile	Wrought aluminium alloy, anodised
5	Cover strip	High-alloy stainless steel

Positioning axes DMES, without guide

Technical data

Characteristic load values

The indicated forces refer to the centre line of the internal diameter of the profile.

They must not be exceeded during dynamic operation. Special attention must be paid to the cushioning phase.

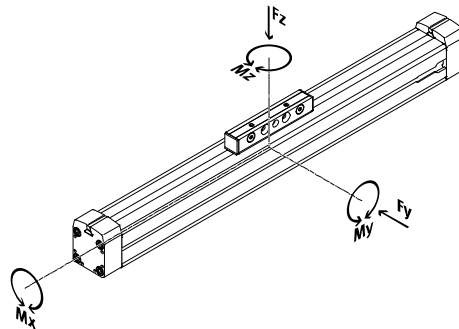

If the axis is subjected to more than two of the indicated forces simultaneously, the following equation must be satisfied in addition to the indicated maximum loads:

$$\frac{|F_y|}{F_{y_{max}}} + \frac{|F_z|}{F_{z_{max}}} + \frac{|M_x|}{M_{x_{max}}} + \frac{|M_y|}{M_{y_{max}}} + \frac{|M_z|}{M_{z_{max}}} \leq 1$$

 Note
Positioning axes DMES without guide are not designed to absorb lateral forces or torques on the slide.

Permissible forces and torques					
Size		18	25	40	63
F _y _{max.}	[N]	36	80	92	300
F _z _{max.}	[N]	80	100	390	900
M _x _{max.}	[Nm]	0.4	1.3	2.2	12
M _y _{max.}	[Nm]	2	4	20	80
M _z _{max.}	[Nm]	0.7	1.6	4.6	22

2nd moment of area

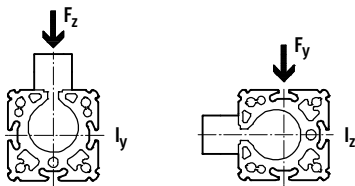

Size		18	25	40	63
ly	[cm ⁴]	6.90	20.92	76.24	587.74
lz	[cm ⁴]	6.83	21.20	71.01	464.30

 Note
Sizing software
PositioningDrives
→ www.festo.com

Positioning axes DMES, without guide

Technical data

Maximum permissible feed force F as a function of the feed speed v

Size 18

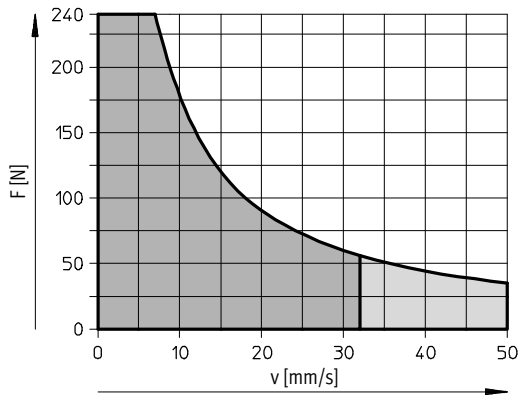

Size 25

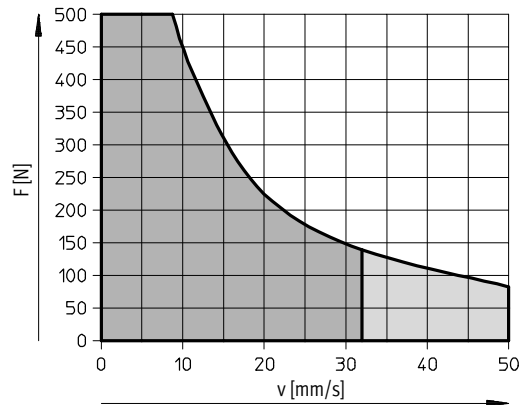

Size 40

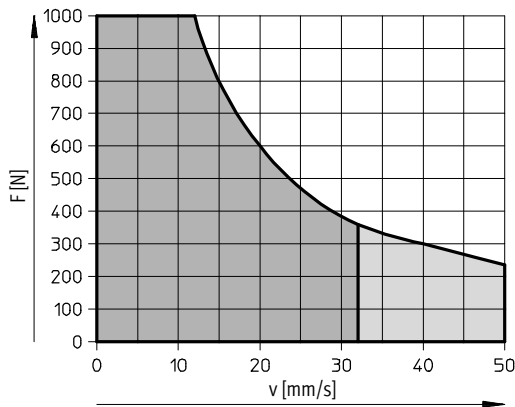

Size 63

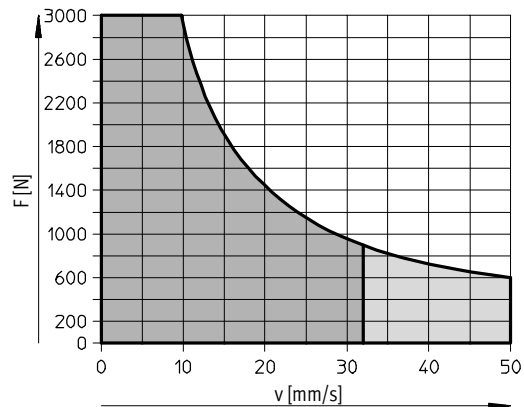

- Recommended operating range
- Permissible operating range (duty cycle < 50% recommended)

Positioning axes DMES, without guide

Technical data

Maximum permissible driving torque M as a function of n (rpm)

Size 18

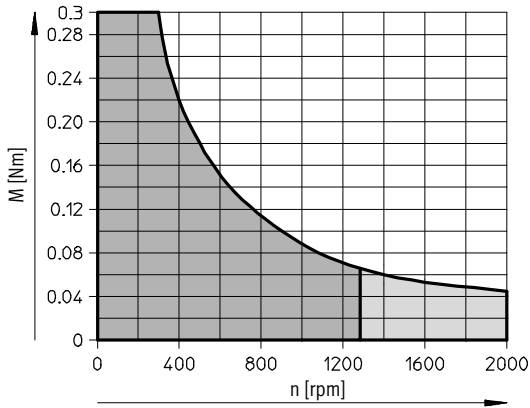

Size 25

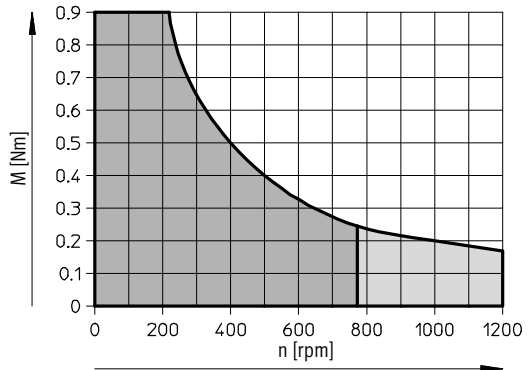

Size 40

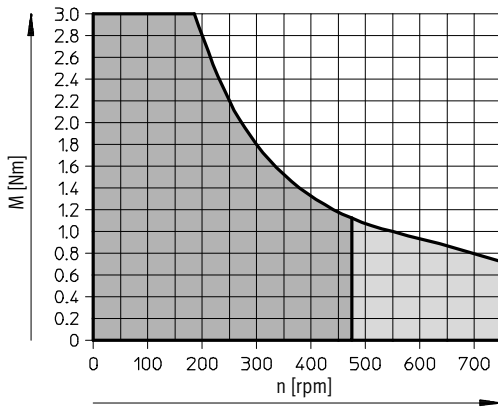

Size 63

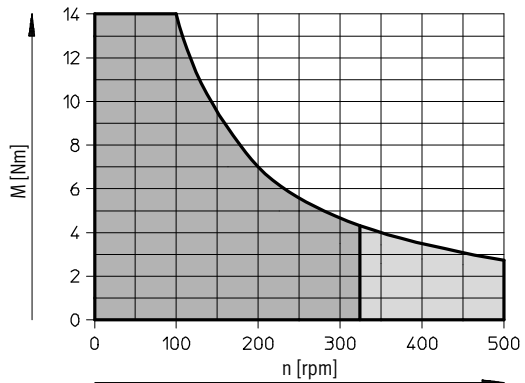

- Recommended operating range
- Permissible operating range (duty cycle < 50% recommended)

Driving torque M as a function of the feed force F

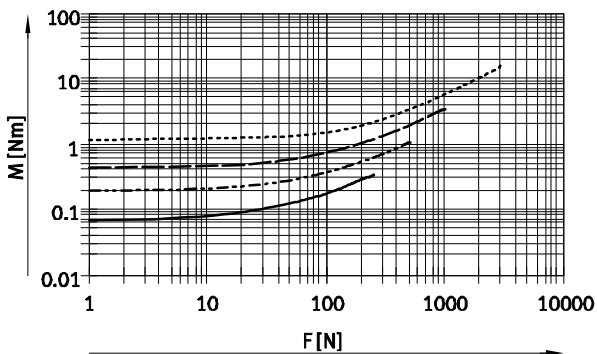

Speed as a function of the feed speed v

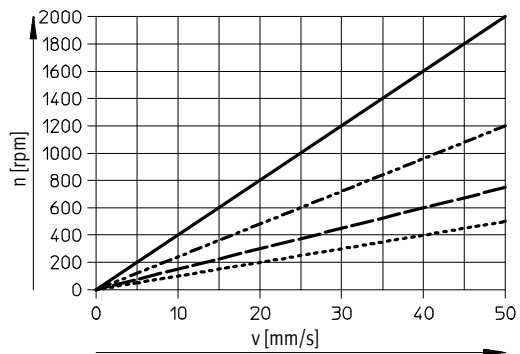

- DMES-18
- - - - - DMES-25
- - - - - DMES-40
- DMES-63

Positioning axes DMES, without guide

Technical data



Dimensions

Download CAD data → www.festo.com

Size 18

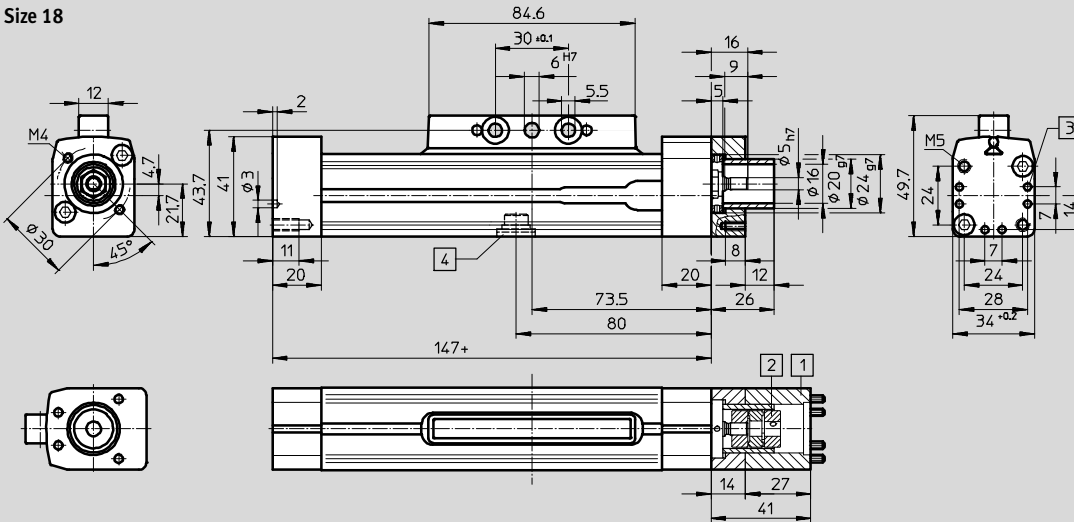

Size 25/40/63

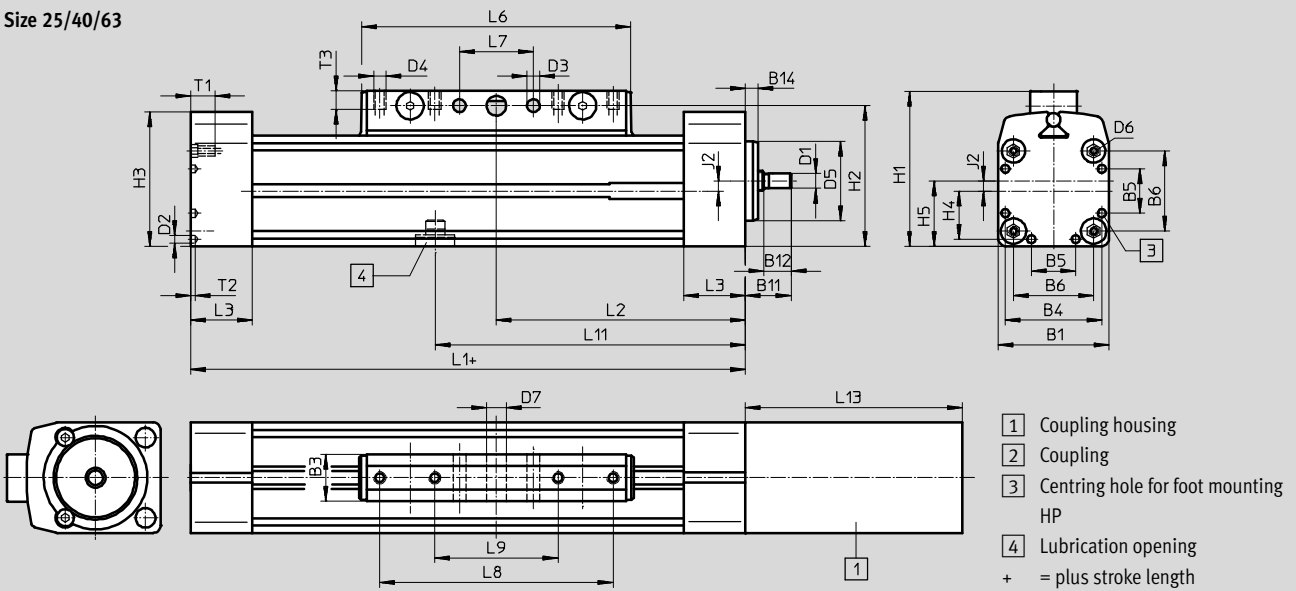

Size	B1	B3	B4	B5	B6	B11	B12	B14	D1	D2	D3	D4	D5	D6	D7	H1	H2	H3
	+0.4								∅ h7	∅	∅		∅ g7		∅ H10			
25	45	19	39.1	18	32.5	18.5	11	4	6	3.3	5.2	M5	32	M4	8	63	57	54.5
40	64	21	53	28	49	33.5	23	5	12	4.4	6.5	M6	48	M5	10	86	78	76.5
63	106	24	89	44	83	47.5	25	7	20	6.4	8.5	M8	72	M8	12	131	122	127.5

Size	H4	H5	J2	L1	L2	L3	L6	L7	L8	L9	L11	L13			T1	T2	T3
												1)	2)	3)			
25	19.6	26.5	4	175	87.5	25	108.8	30	–	50	105	88	101	–	13	2	7.5
40	26.5	37	5	250	126	31	170.8	70	130	40	151	121	135	–	13	6	10
63	44.5	61	8	328	164	36	233.8	110	190	70	196	150	150	150	21	6	12.5

- 1) When combined with motor unit MTR-DCI with gear reduction 7:1.
- 2) When combined with motor unit MTR-DCI with gear reduction 14:1.
- 3) When combined with motor unit MTR-DCI with gear reduction 22:1.

Positioning axes DMES, without guide

Technical data



Dimensions

Download CAD data → www.festo.com

Profile

Size 18

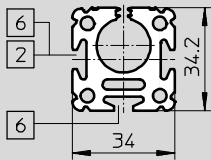

Size 25

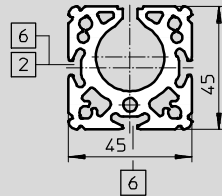

Size 40

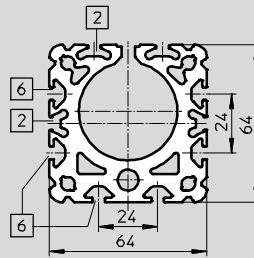

Size 63

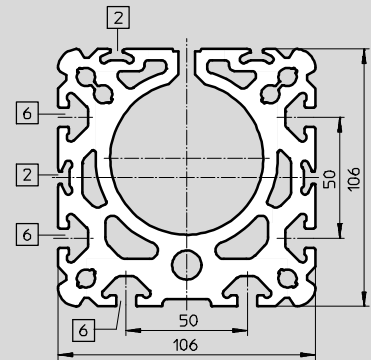

2 Sensor slot for proximity sensor

6 Mounting slot for slot nut NST

Positioning axes DMES, without guide

Ordering data – Modular products

Order processing for positioning axis DMES in combination with intelligent motor unit MTR-DCI

1 Ordering positioning axis DMES [Ordering table → 15](#)

3 Ordering intelligent motor unit MTR-DCI [Ordering table → LEERER MERKER](#)

The drive unit and corresponding accessories are configured in the ordering table for the positioning axis DMES.

The motor unit order code determined from table 2 must now be completed with the “gear unit” and “parameterisation interface” codes.

The code “AX” or “U” is used to specify whether an intelligent motor unit MTR-DCI and an axial or a parallel kit are required for the positioning axis.

The module number of the intelligent motor unit must not be specified when ordering with order code “AX” or “U”. It is determined automatically.

The motor unit design must be defined separately.

1) Mounting data				2) Options		
Module No.	Position	Size	Stroke	Motor unit	Accessories	Accessories supplied later
E33 400	DMES	25	70 - 1,200	42		25, 26, 27, 28, 29
E33 500		25				
E33 550		40				
E33 700		63				

Ordering table							
Size	25	40	63	Stroke	Stroke	Motor unit	
Motor unit	E33 400	E33 500	E33 550	E33 700		DMES	
Position	Drive stroke without guide DMES						DMES
Size	25	25	40	63			
Stroke	70 - 1,200	70 - 700	70 - 1,200	70 - 1,200			
Motor unit	Motor unit including electric sensorless motor						42
Motor unit	Optional: integrated						42
Kit code	U - 01						
Kit code	Winding kit						
Kit code	Winding kit						
Kit code	Winding kit						
Kit code	Winding kit						
Kit code	Winding kit						

3) Accessories data										
Module No.	Motor unit	Type of motor	Range size	Length (mm)	Rated voltage	Peak voltage	Displacement (mm)	Motor unit	Parameterisation interface	Electrical connection technology
	42	DC	50	1	24	32	0	42	42	01
			60		24	32		42	42	01
			70		24	32		42	42	01
			80		24	32		42	42	01

Ordering table							
Size	25	40	50	63	Stroke	Stroke	
Motor unit							
Type of motor	DC servo motor with integrated position controller						42
Parameterisation	01	42	50	63			42
Range size	Standard range size						5
Length (mm)	50	60	70	80			42
Rated voltage	24 V DC						42
Peak voltage	32 V DC						42
Displacement (mm)	0 mm						42
Motor unit	Integrated planetary gearbox (1:6.7)						42
	Integrated planetary gearbox (1:11.7)						42
	Integrated planetary gearbox (1:20.2)						42
Parameterisation interface	MTR-DCI interface						42
	MTR-DCI interface + integrated						42
Electrical connection technology	01: parallel						42

2 Permissible combinations with intelligent motor unit MTR-DCI

Positioning axis	Motor unit
DMES-18-...	MTR-DCI-32S-VCSC-E...
DMES-25-...	MTR-DCI-42S-VCSC-E...
DMES-40-...	MTR-DCI-52S-VCSC-E...
DMES-63-...	MTR-DCI-62S-VDSC-E...

4 Order example

Part No.	Type
	Positioning axis DMES
533 700	DMES-25-700-AX:ZUB-2S2Y1M1F
	Intelligent motor unit MTR-DCI
-	MTR-DCI-42S-VCSC-EG7-R210

Note
 Servo, stepper motors and the corresponding mounting kits must be ordered separately → 42

Positioning axes DMES, without guide

Ordering data – Modular products

Order code

Mandatory data

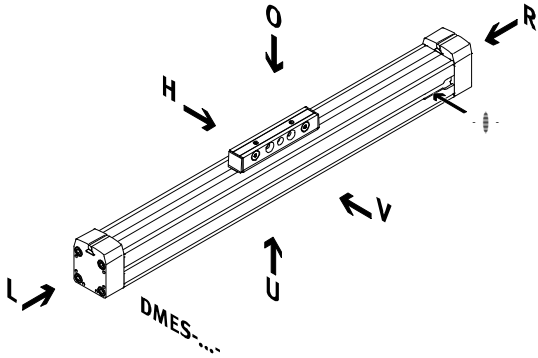

<p>-  - Note</p> <p>The insertion point for the proximity sensor is located on the right-hand side of the positioning axis.</p>	<p>O top U underneath V front H rear R right L left</p>
--	--

Order code

Options

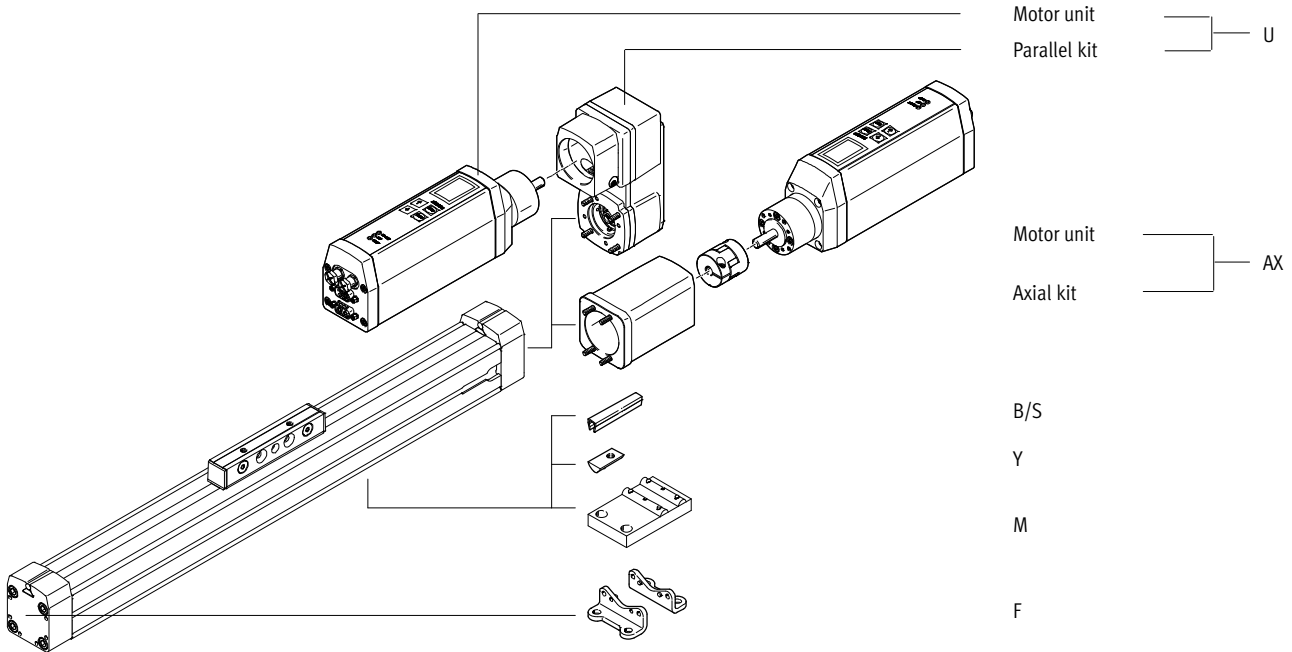

Positioning axes DMES, without guide

Ordering data – Modular products

M Mandatory data				O Options		
Module No.	Function	Size	Stroke	Motor unit	Accessories	Accessories supplied loose
533699	DMES	18	50 ... 1,800	AX U		...S, ...B, ...Y, ...M, ...F
533700		25				
533701		40				
533702		63				
Order example						
533700	DMES	- 25	- 700	-	: ZUB	- 2S2Y2M

MTR-DCI-...S-...SC-E-...IO

Ordering table							
Size	18	25	40	63	Condi- tions	Code	Enter code
M Module No.	533699	533700	533701	533702			
Function	Positioning axis without guided slide					DMES	DMES
Size	18	25	40	63		-...	
Stroke [mm]	50 ... 400	50 ... 700	50 ... 1,200	50 ... 1,800		-...	
O Motor unit	Axial kit and motor unit (enclosed separately)				1	-AX	
	Parallel kit and motor unit (enclosed separately)				-	U	
Accessories	Supplied separately					:ZUB-	:ZUB-
Slot cover	Sensor slot	1 ... 10				...S	
	Mounting slot	-	-	1 ... 10		...B	
Slot nut	Mounting slot	1 ... 10				...Y	
Central support	1 ... 10					...M	
Foot mounting	1 ... 10					...F	

1 AX, U Order processing for intelligent motor unit MTR-DCI → LEERER MERKER.

Transfer order code

DMES - - - : **ZUB** -

MTR-DCI-...S-...SC-E-...IO

Positioning axes DMES-GF/-KF, with guide

Peripherals overview

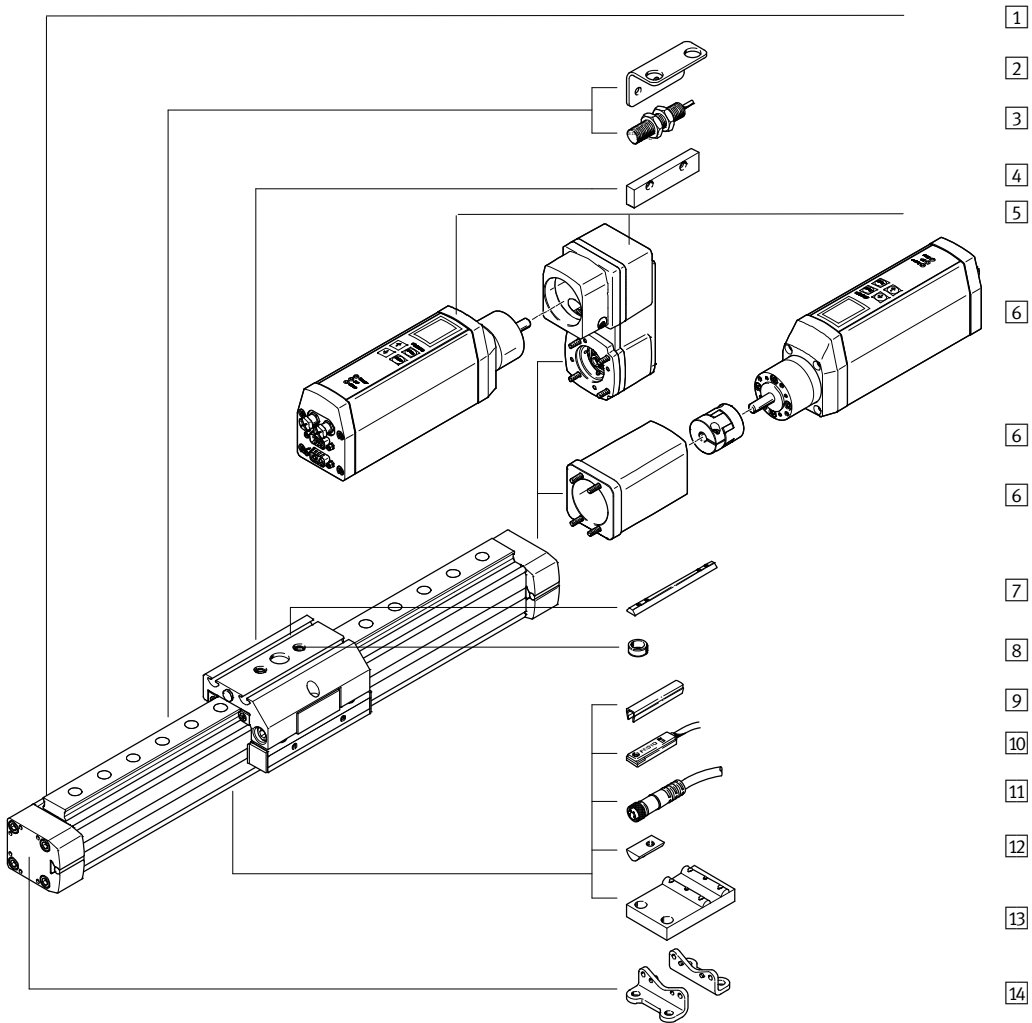

Positioning axes DMES-GF/-KF, with guide

Peripherals overview

Variants and accessories				
Type/Order code	Brief description	GK/GV	GA	→ Page/Internet
1	Positioning axis DMES	■	■	20
2	Sensor retainer T	■	-	47
3	Inductive proximity sensor SIEN	■	-	48
4	Switching lug L	■	-	47
5	Motor unit and parallel kit U	■	■	39
6	Motor unit and axial kit AX	■	■	39
7	Slot nut for slide X	■	■	49
8	Centring sleeves Z	■	■	49
9	Slot cover B/S	■	■	49
10	Proximity sensor SMT-8	■	■	48
11	Connecting cable KM8	■	■	48
12	Slot nut for mounting slot Y	■	■	49
13	Central support M	■	■	46
14	Foot mounting F	■	■	46

GK: Standard slide
 GV: Extended slide
 GA: Protected version

 Note
 Servo, stepper motors and the corresponding mounting kits must be ordered separately → 42

Positioning axes DMES-GF/-KF, with guide

Type code

DMES - 25 - 500 - KF - GK - SH - - AX

Type	
DMES	Positioning axis
Size	
Stroke [mm]	
Guide	
GF	Plain-bearing guide
KF	Recirculating ball bearing guide
Slide	
GK	Standard slide
GV	Extended slide
GA	Protected version
Slide attachment position	
SV	Front
SH	Rear
Additional slide	
KL	Left
KR	Right
Motor unit	
AX	Motor unit and axial kit
U	Motor unit and parallel kit

Positioning axes DMES-GF/-KF, with guide

Type code



:ZUB - [] 2X 2M [] Z 2T L

Accessories

ZUB Accessories supplied loose

Slot cover

...S Sensor slot

...B Mounting slot

Slot nut

...Y For mounting slot

...X For slide

Central support

...M Central support

Foot mounting

...F Foot mounting

Centring sleeves

...Z For slide

Mounting bracket

...T For inductive proximity sensors

Switching lug

L Switching lug

Positioning axes DMES-GF/-KF, with guide

Technical data

Function

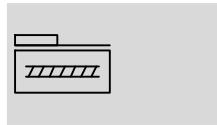

Size
18 ... 63

Stroke length
50 ... 1,800 mm

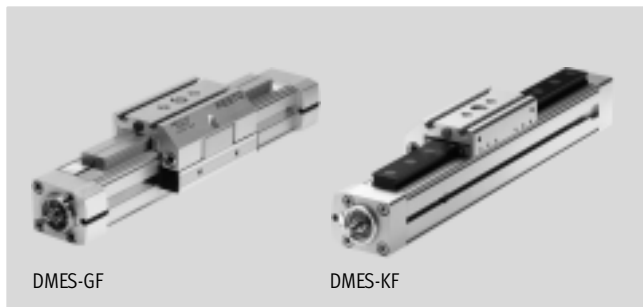

General technical data					
Size		18	25	40	63
Design		Electromechanical linear axis with lead-screw spindle			
Guide		With plain-bearing guide or recirculating ball bearing guide			
Assembly position		Any			
Working stroke	[mm]	50 ... 400	50 ... 700	50 ... 1,200	50 ... 1,800
Max. feed force F_x	[N]	240	500	1,000	3,000
Max. driving torque	[Nm]	0.3	0.9	3	14
Max. no-load driving torque ¹⁾	[Nm]	0.07	0.2	0.45	1.1
Max. radial force ²⁾	[N]	40	75	250	800
Max. speed	[m/s]	0.05			
Max. acceleration	[m/s ²]	2.5			
Repetition accuracy	[mm]	±0.05			±0.07
Positioning rigidity	[N/mm]	1,700	2,300	4,200	5,600
Duty cycle	[%]	100			
Reversing backlash ³⁾	[mm]	< 0.1			

1) Measured at a speed of 200 rpm.

2) On drive shaft

3) In new condition

Operating and environmental conditions		
Ambient temperature ¹⁾	[°C]	0 ... +50
Protection class		IP40

1) Note operating range of proximity sensors

Weights [kg]									
Size		18		25		40		63	
Guide type		GF	KF	GF	KF	GF	KF	GF	KF
Basic weight with 0 mm stroke ¹⁾	GK	0.77	0.93	1.52	1.70	4.11	5.06	13.31	16.48
	GV	1.16	1.37	2.34	2.61	6.53	8.06	21.75	27.14
	GA	1.49	1.65	2.73	2.90	7.15	8.14	–	–
Additional weight per 100 mm stroke	GK	0.238	0.294	0.466	0.547	0.841	1.170	2.079	2.958
	GV	0.238	0.294	0.466	0.547	0.841	1.170	2.079	2.958
	GA	0.313	0.369	0.556	0.638	0.965	1.294	–	–
Moving load	GK	0.29	0.38	0.55	0.66	1.49	1.83	4.48	5.29
	GV	0.48	0.56	0.88	0.99	2.38	2.72	7.06	7.88
	GA	0.71	0.81	1.19	1.30	2.90	3.24	–	–
Additional slide	KL/KR	–	0.29	–	0.440	–	1.21	–	3.55

1) Without coupling housing

Positioning axes DMES-GF/-KF, with guide

Technical data

Mass moment of inertia										
Size		18		25		40		63		
Guide type		GF	KF	GF	KF	GF	KF	GF	KF	
J_0	GK	[kg cm ²]	0.0030	0.0030	0.0156	0.0158	0.1865	0.1879	1.8018	1.8093
	GV	[kg cm ²]	0.0048	0.0049	0.0263	0.0265	0.3327	0.3340	3.2184	3.2258
	GA	[kg cm ²]	0.0038	0.0039	0.0209	0.0212	0.2463	0.2476	–	–
j_H per metre stroke		[kg cm ² /m]	0.0210	0.0210	0.0980	0.0980	0.8400	0.8400	5.5600	5.5600
j_L per kg working load		[kg cm ² /Kg]	0.0006	0.0006	0.0023	0.0023	0.0041	0.0041	0.0091	0.0091
j_W for additional slide		[kg cm ²]	–	0.0002	–	0.0010	–	0.0049	–	0.0324

The mass moment of inertia J_A of the entire axis is calculated as follows:

$$J_A = J_0 + j_H \times \text{working stroke [m]} + j_L \times m_{\text{working load [kg]}} + i \times j_W$$

i = Number of additional slides

Spindle					
Size		18	25	40	63
Diameter	[mm]	8	12	20	32
Pitch	[mm/rev.]	1.5	2.5	4	6

Materials

Sectional view

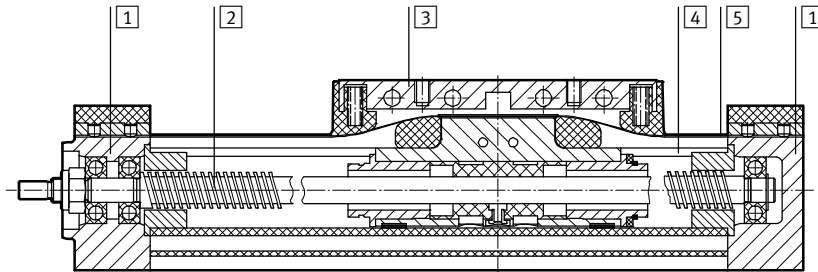

Positioning axis		
1	Cover	Wrought aluminium alloy, anodised
2	Spindle	Steel
3	Piston, driver	Wrought aluminium alloy, anodised
4	Profile	Wrought aluminium alloy, anodised
5	Cover strip	High-alloy stainless steel
–	Guide rail for GF	Anodised aluminium
–	Guide rail for KF	Hardened steel

Positioning axes DMES-GF/-KF, with guide

Technical data



Characteristic load values for axis with standard slide GK or protected version GA

The indicated forces and torques refer to the centre of the guide rail. They must not be exceeded during dynamic operation. Special attention must be paid to the cushioning phase.

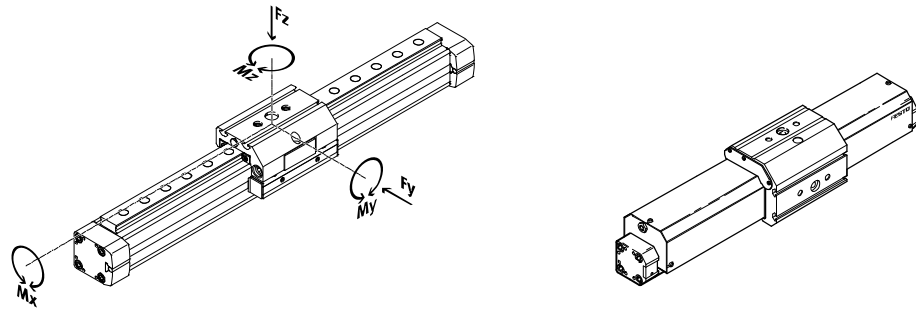

If the axis is subjected to more than two of the indicated forces and torques simultaneously, the following equation must be satisfied in addition to the indicated maximum loads:

$$\frac{|F_y|}{F_{y_{max}}} + \frac{|F_z|}{F_{z_{max}}} + \frac{|M_x|}{M_{x_{max}}} + \frac{|M_y|}{M_{y_{max}}} + \frac{|M_z|}{M_{z_{max}}} \leq 1$$

Permissible forces and torques

Size	18		25		40		63	
Guide type	GF	KF	GF	KF	GF	KF	GF	KF
F _y _{max.} [N]	930	930	1,760	2,600	3,070	4,300	3,880	6,600
F _z _{max.} [N]	930	930	1,760	2,600	4,300	4,300	6,600	6,600
M _x _{max.} [Nm]	7	7	24	45	98	160	220	400
M _y _{max.} [Nm]	23	23	52	85	210	330	580	910
M _z _{max.} [Nm]	23	23	52	85	210	330	580	910

2nd moment of area

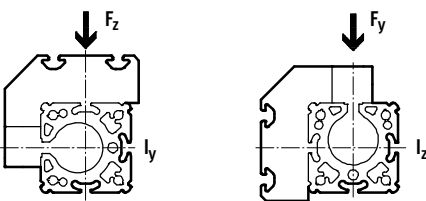

Size	18		25		40		63	
Guide type	GF	KF	GF	KF	GF	KF	GF	KF
I _y [cm ⁴]	11.19	14.37	39.10	47.60	125.38	176.24	709.04	992.06
I _z [cm ⁴]	7.11	7.16	25.85	23.34	84.76	95.43	614.44	693.35

- - Note
Sizing software
PositioningDrives
→ www.festo.com

Positioning axes DMES-GF/-KF, with guide

Technical data

Characteristic load values for axis with extended slide GV

The indicated forces and torques refer to the centre of the guide rail. They must not be exceeded during dynamic operation. Special attention must be paid to the cushioning phase.

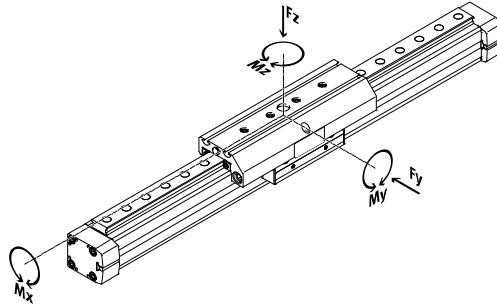

If the axis is subjected to more than two of the indicated forces and torques simultaneously, the following equation must be satisfied in addition to the indicated maximum loads:

$$\frac{|F_y|}{F_{y_{max}}} + \frac{|F_z|}{F_{z_{max}}} + \frac{|M_x|}{M_{x_{max}}} + \frac{|M_y|}{M_{y_{max}}} + \frac{|M_z|}{M_{z_{max}}} \leq 1$$

Permissible forces and torques

Size	18		25		40		63	
Guide type	GF	KF	GF	KF	GF	KF	GF	KF
F _y _{max.} [N]	930	930	1,650	3,080	3,990	7,300	7,250	13,900
F _z _{max.} [N]	930	930	1,650	3,080	3,990	7,300	7,250	14,050
M _x _{max.} [Nm]	7	7	23	45	89	170	290	580
M _y _{max.} [Nm]	45	45	95	170	360	660	980	1,820
M _z _{max.} [Nm]	45	45	95	170	360	660	980	1,820

2nd moment of area

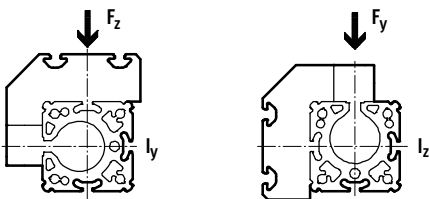

Size	18		25		40		63	
Guide type	GF	KF	GF	KF	GF	KF	GF	KF
I _y [cm ⁴]	11.19	14.37	39.10	47.60	125.38	176.24	709.04	992.06
I _z [cm ⁴]	7.11	7.16	25.85	23.34	84.76	95.43	614.44	693.35

Positioning axes DMES-GF/-KF, with guide

Technical data

FESTO

Deflection of the positioning axis as a function of the working load F and the support span l

The following diagrams can be used to determine the deflection of a positioning axis supported externally at both ends (see drawing below). A differentiation is made between two load directions. The axis may also need to be supported with central supports MUP in order to limit deflection in the case of large strokes.

Deflection along the y-axis

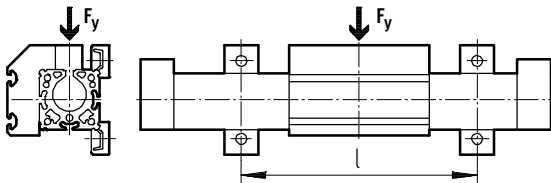

Deflection along the z-axis

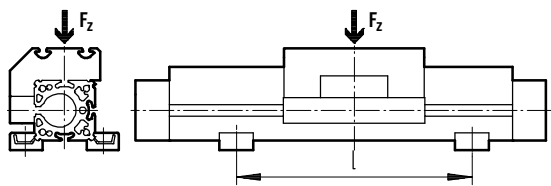

Example showing how to determine deflection

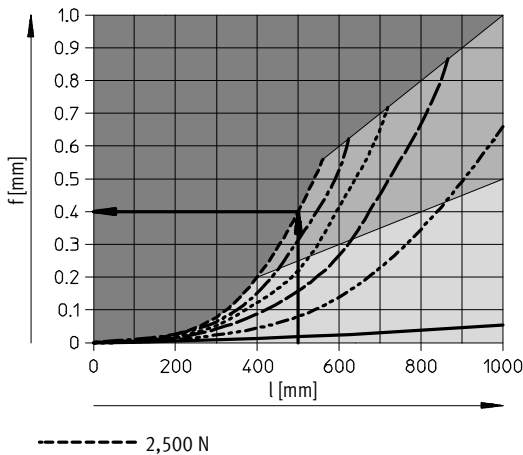

Given:

Positioning axis
DMES-25-700-KF-...

Working stroke = 700 mm
Total length of the positioning axis,
dimensional drawing \rightarrow 31
700 mm + 175 mm = 875 mm
Working load F = 2,500 N
Support span l = 500 mm

To be found:

Deflection f

Procedure:

A support span of 500 mm (see X-axis) and a working load of 2,500 N (see characteristic curve) produces a deflection of 0.4 mm.

Note:

The slide may not be moved under this load as the operating point is in the static area of the diagram. In order to be able to operate the slide dynamically, the support span must be reduced to 400 mm.

	Impermissible range:	The positioning axis may not be used.
	Static range:	The slide must not be moved under load.
	Static and dynamic range:	The slide must be moved under load.

Positioning axes DMES-GF/-KF, with guide

Technical data

Deflection of the positioning axis as a function of the working load F and the working stroke l

Along the y-axis

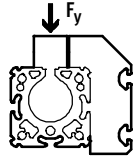

Along the z-axis

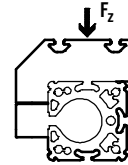

DMES-18-GF, with plain-bearing guide

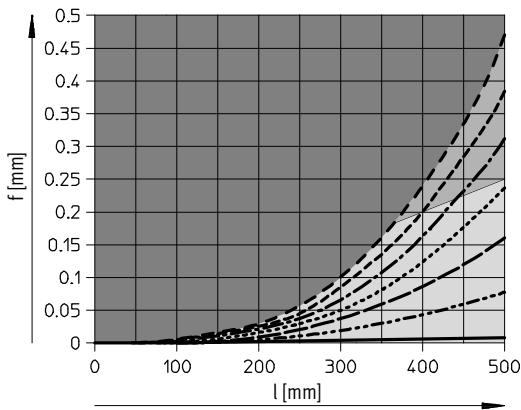

DMES-18-GF, with plain-bearing guide

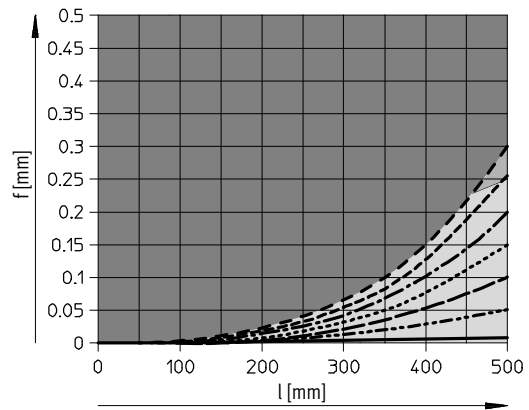

DMES-18-KF, with recirculating ball bearing guide

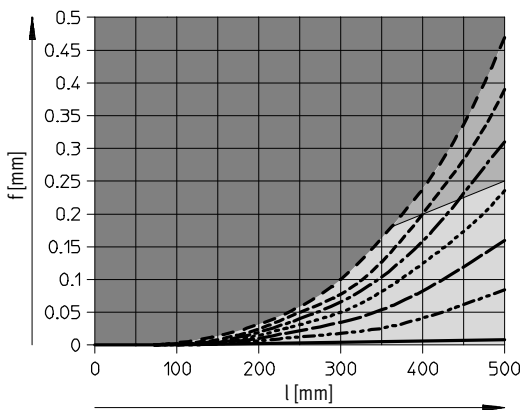

DMES-18-KF, with recirculating ball bearing guide

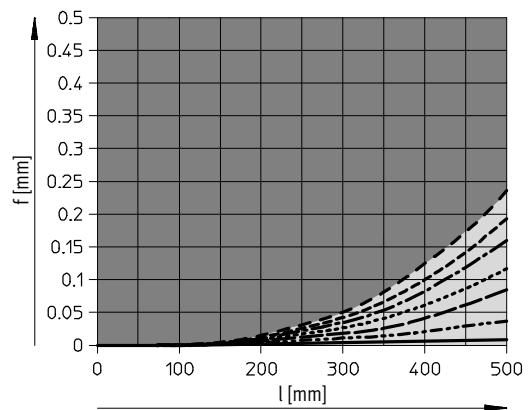

- Impermissible range
- Static range
- Static and dynamic range

Positioning axes DMES-GF/-KF, with guide

Technical data



Deflection of the positioning axis as a function of the working load F and the working stroke l

Along the y-axis

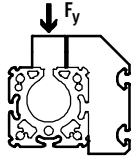

Along the z-axis

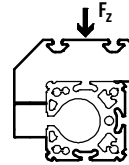

DMES-25-GF, with plain-bearing guide

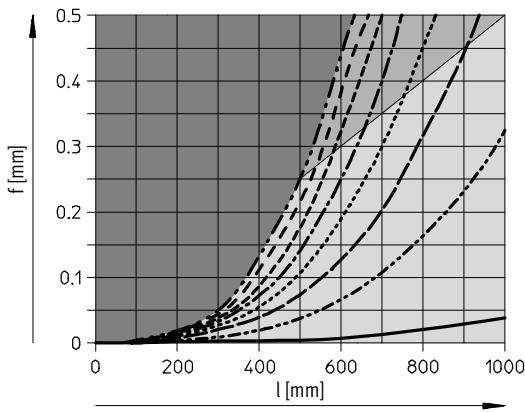

DMES-25-GF, with plain-bearing guide

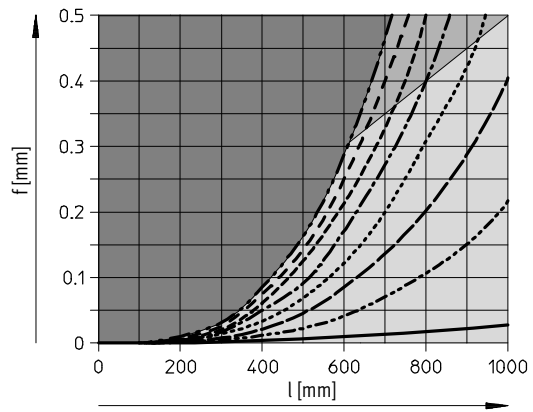

DMES-25-KF, with recirculating ball bearing guide

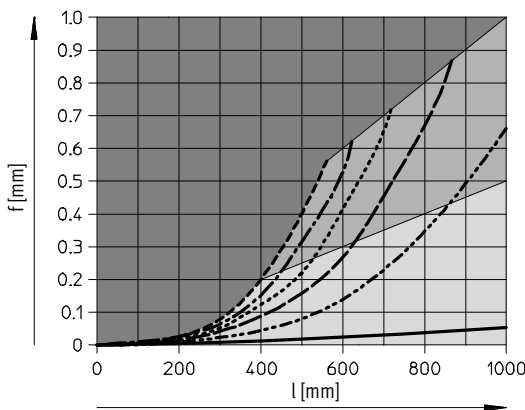

DMES-25-KF, with recirculating ball bearing guide

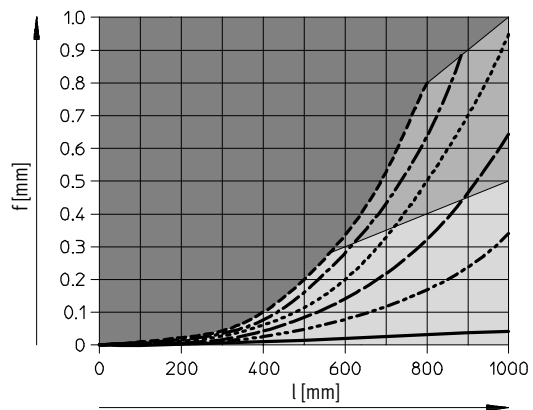

- Impermissible range
- Static range
- Static and dynamic range

Positioning axes DMES-GF/-KF, with guide

Technical data

Deflection of the positioning axis as a function of the working load F and the working stroke l

Along the y-axis

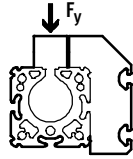

Along the z-axis

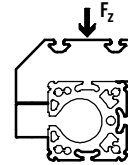

DMES-40-GF, with plain-bearing guide

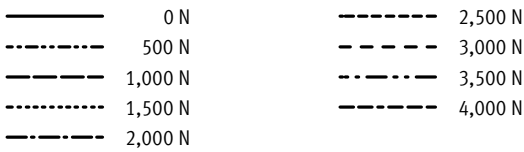
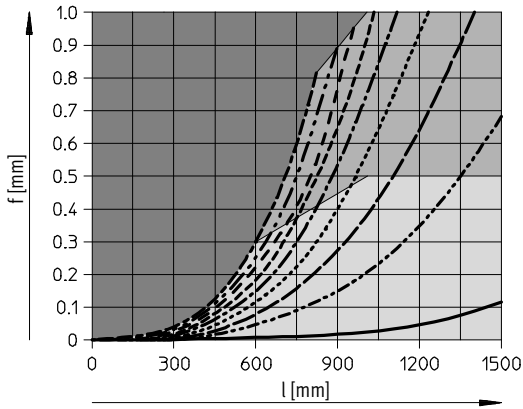

DMES-40-GF, with plain-bearing guide

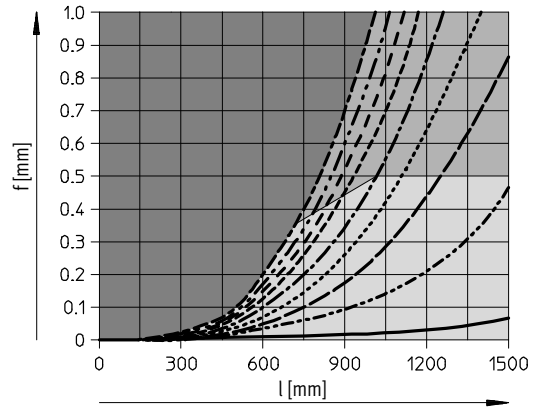

DMES-40-KF, with recirculating ball bearing guide

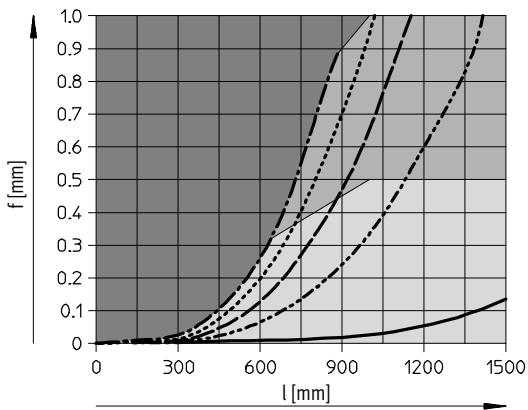

DMES-40-KF, with recirculating ball bearing guide

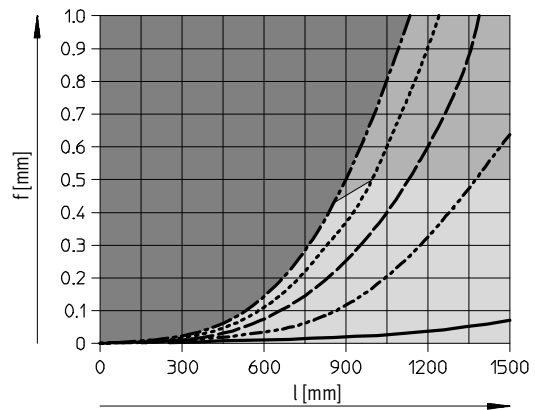

- Impermissible range
- Static range
- Static and dynamic range

Positioning axes DMES-GF/-KF, with guide

Technical data



Deflection of the positioning axis as a function of the working load F and the working stroke l

Along the y-axis

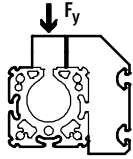

Along the z-axis

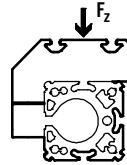

DMES-63-GF, with plain-bearing guide

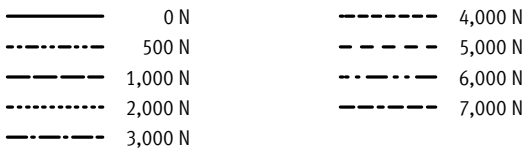
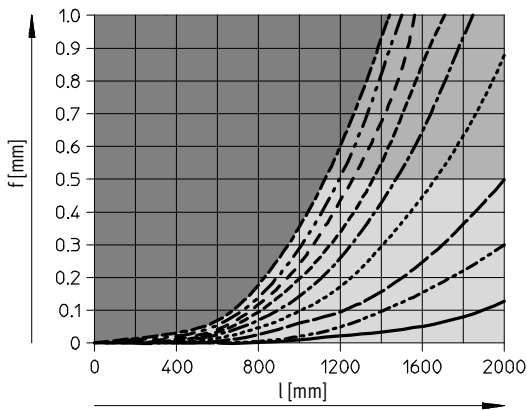

DMES-63-GF, with plain-bearing guide

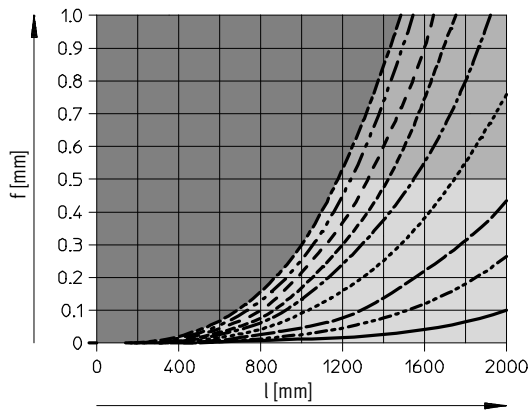

DMES-63-KF, with recirculating ball bearing guide

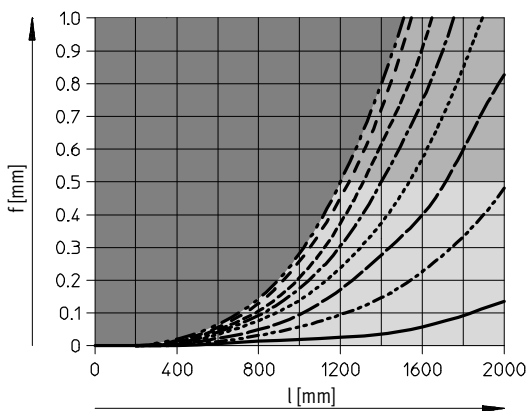

DMES-63-KF, with recirculating ball bearing guide

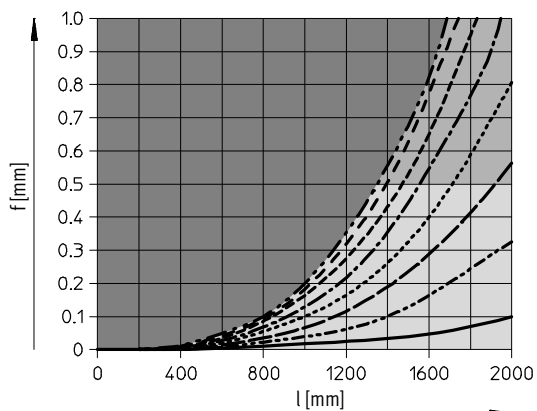

- Impermissible range
- Static range
- Static and dynamic range

Positioning axes DMES-GF/-KF, with guide

Technical data

Maximum permissible feed force F as a function of the feed speed v

Size 18

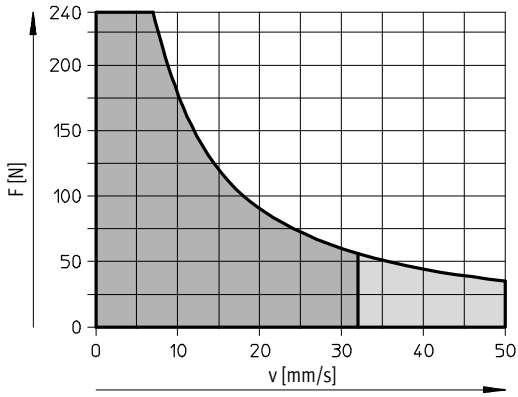

Size 25

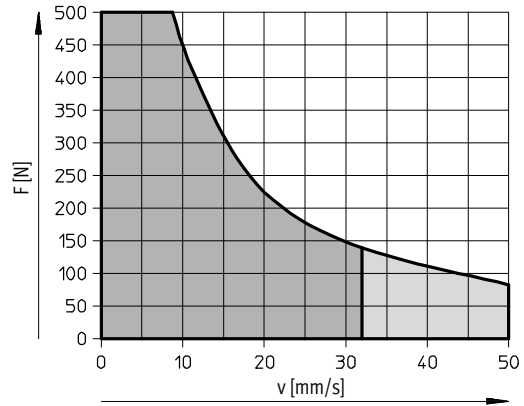

Size 40

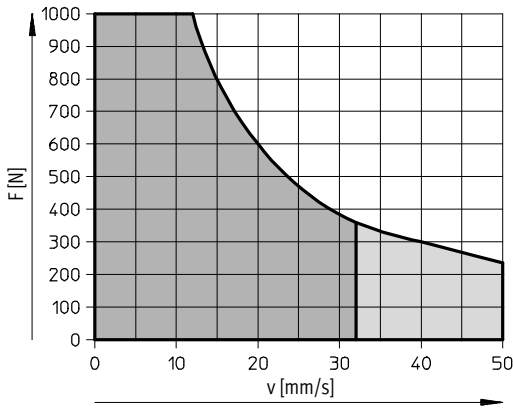

Size 63

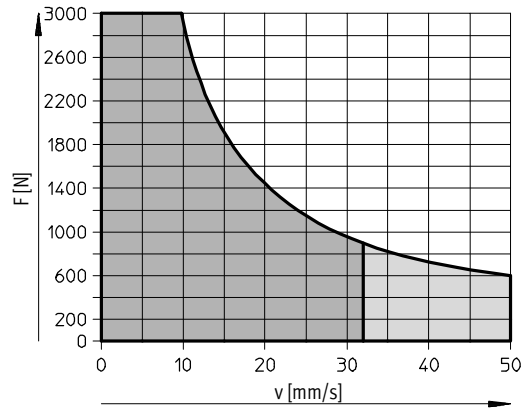

- Recommended operating range
- Permissible operating range (duty cycle < 50% recommended)

Positioning axes DMES-GF/-KF, with guide

Technical data

FESTO

Maximum permissible driving torque M as a function of n (rpm)

Size 18

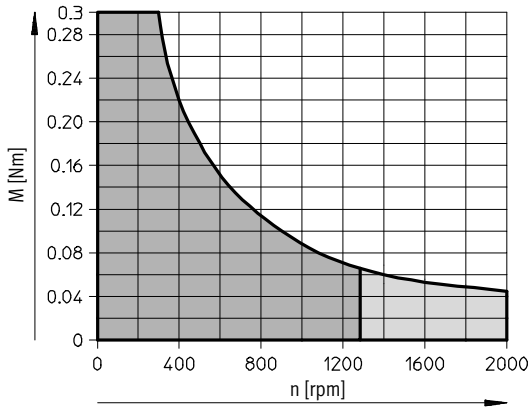

Size 25

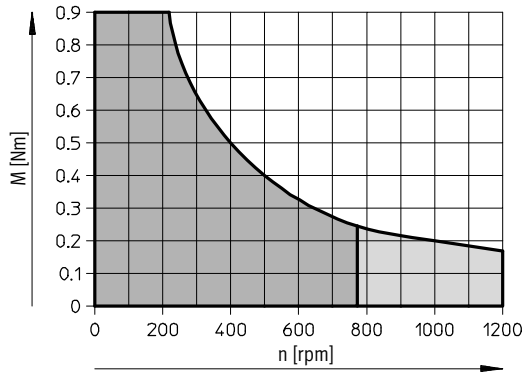

Size 40

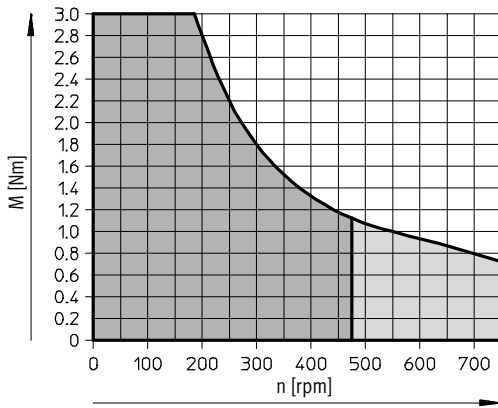

Size 63

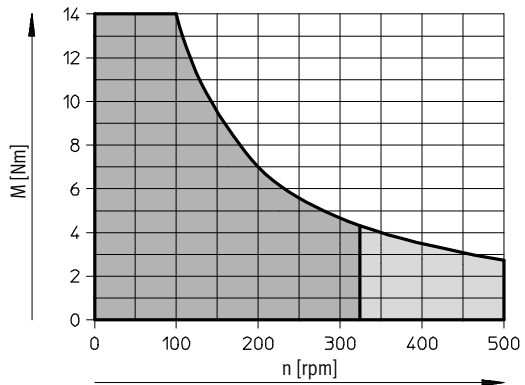

- Recommended operating range
- Permissible operating range (duty cycle < 50% recommended)

Driving torque M as a function of the feed force F

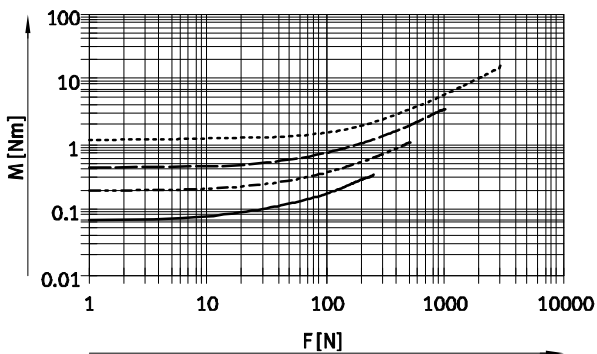

Speed as a function of the feed speed v

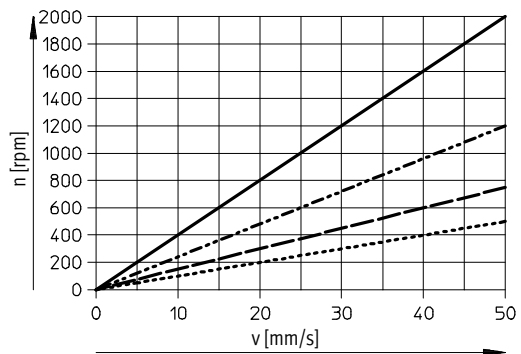

- DMES-18
- - - - - DMES-25
- · - · - DMES-40
- · · · · DMES-63

Positioning axes DMES-GF/-KF, with guide

Technical data

Dimensions Download CAD data → www.festo.com

Standard slide GK

Size 18

- 5 Hole for centring pin ZBS-5

Basic dimensions
→ 11

Size 25/40/63

- 5 Hole for centring pin ZBH-9
- 6 Mounting slot for slot nut NSTL
- 7 Hole for central mounting SLZZ

+ = plus stroke length

Basic dimensions
→ 11

Size 25

Size	B7	B8	B9	D10	D11	H7	H10	H11	L1	L2	L17	L19	T4	T8
			±0.2		∅ G7			+0.3				±0.1	max.	
25	48	67	32	M5	14	68.5	18.5	8.2	175	87.5	105	88	12.5	8.5
40	78.5	96.5	55	M5	25	90.5	20	7	250	126	167	150	12.5	8.5
63	121	142	90	M8	25	144.5	30	12.5	328	164	230	200	20.5	10.5

Positioning axes DMES-GF/-KF, with guide

Technical data

Dimensions

Download CAD data → www.festo.com

Standard slide GK

Size 40/63

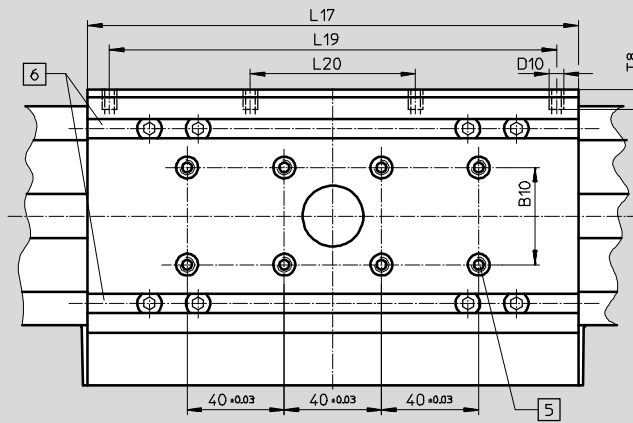

- 5 Hole for centring pin ZBH-9
- 6 Mounting slot for slot nut NSTL
- + = plus stroke length

Additional slide KL/KR

Size 18

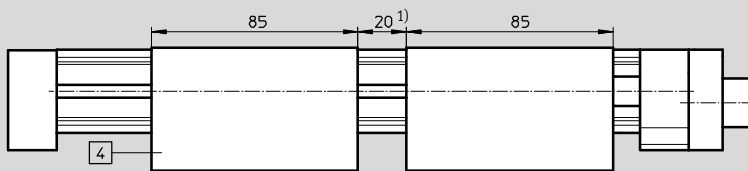

- 4 Additional slide DMES-...-KL/KR

1) Recommended minimum distance for access to lubrication nipple

Size 25/40/63

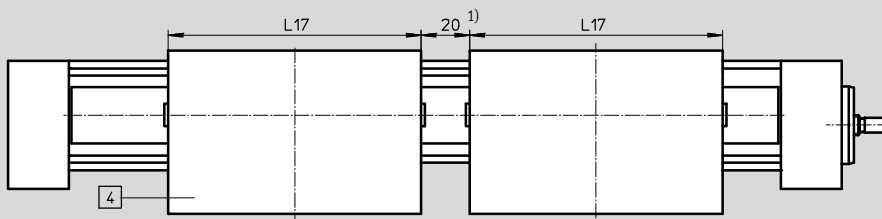

- 4 Additional slide DMES-...-KL/KR

1) Recommended minimum distance for access to lubrication nipple

Size	D10	L17	L19	L20	T8
			±0.1	±0.1	
25	M5	105	88	–	8.5
40	M5	167	150	58	8.5
63	M8	230	200	72	10.5

Positioning axes DMES-GF/-KF, with guide

Technical data

Dimensions Download CAD data → www.festo.com

Profile

Size 18

Size 25

Size 40

Size 63

2 Sensor slot for proximity sensor

6 Mounting slot for slot nut NST

Positioning axes DMES-GF/-KF, with guide

Technical data



Dimensions

Download CAD data → www.festo.com

Extended slide GV

Size 18

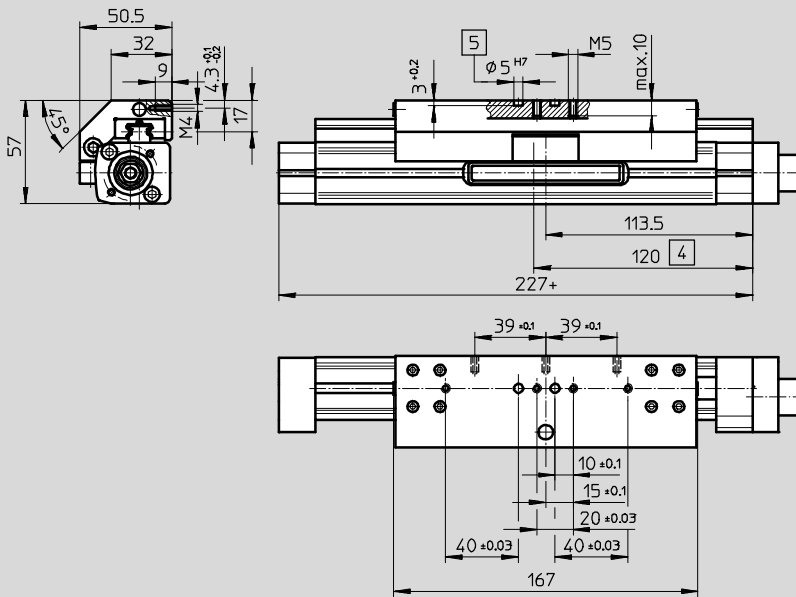

- 4 Lubrication opening
- 5 Hole for centring pin ZBS-5
- + = plus stroke length

Basic dimensions

→ 11

Positioning axes DMES-GF/-KF, with guide

Technical data

FESTO

Dimensions

Extended slide GV

Download CAD data → www.festo.com

Size 25/40/63

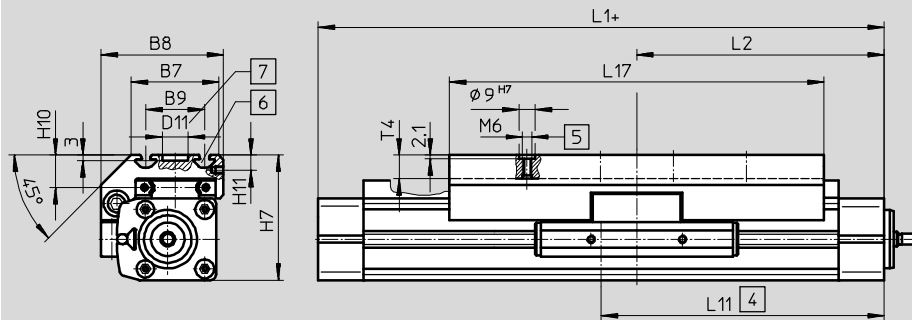

- 4 Lubrication opening
- 5 Hole for centring pin ZBS-9
- 6 Slot for slot nut NSTL
- 7 Hole for central mounting SLZZ
- + = plus stroke length

Basic dimensions

→ 11

Size 25

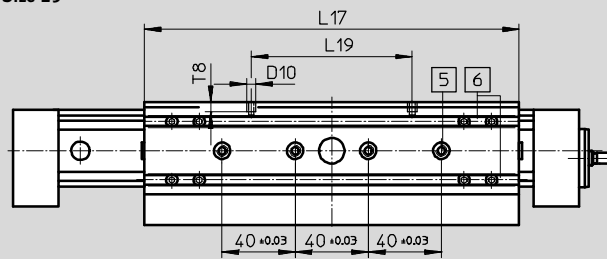

Size 40

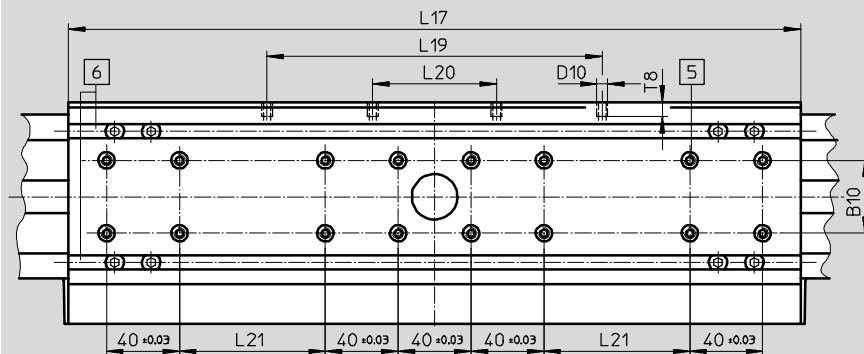

- 5 Hole for centring pin ZBH-9
- 6 Mounting slot for slot nut NSTL

Size	B7	B8	B9	B10	D10	D11	H7	H10	H11
			±0.2	–	M5	14			+0.3
25	48	67	32	–	M5	14	68.5	18.5	8.2
40	78.5	96.5	55	20	M5	25	90.5	20	7
63	121	142	90	40	M8	25	144.5	30	12.5

Size	L1	L2	L11	L17	L19	L20	L21	T4	T8
				±0.1	±0.1	±0.1	±0.1	max.	
25	275	137.5	155	205	88	–	–	12.5	8.5
40	420	211	236	337	150	58	40	12.5	8.5
63	578	289	321	480	200	72	120	20.5	10.5

Positioning axes DMES-GF/-KF, with guide

Technical data

Dimensions

Download CAD data → www.festo.com

Protected version GA

Size 18

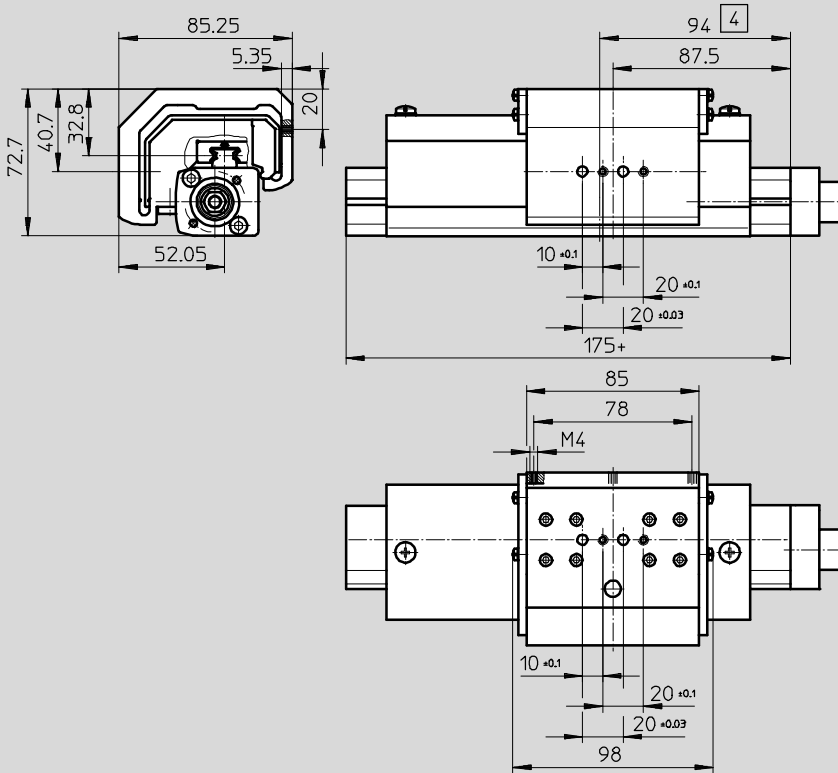

Size 25

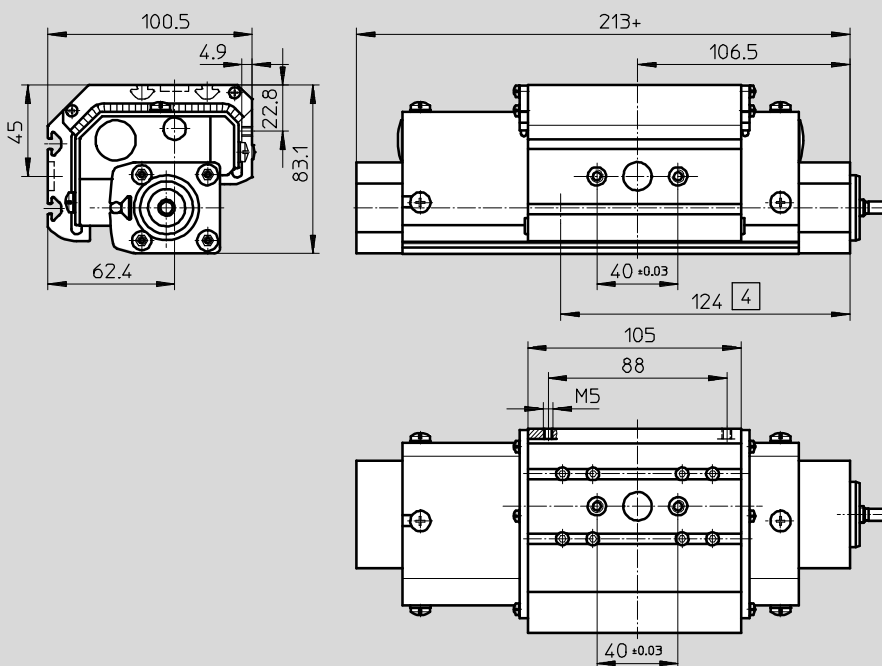

Positioning axes DMES-GF/-KF, with guide

Technical data

FESTO

Dimensions

Download CAD data → www.festo.com

Protected version GA

Size 40

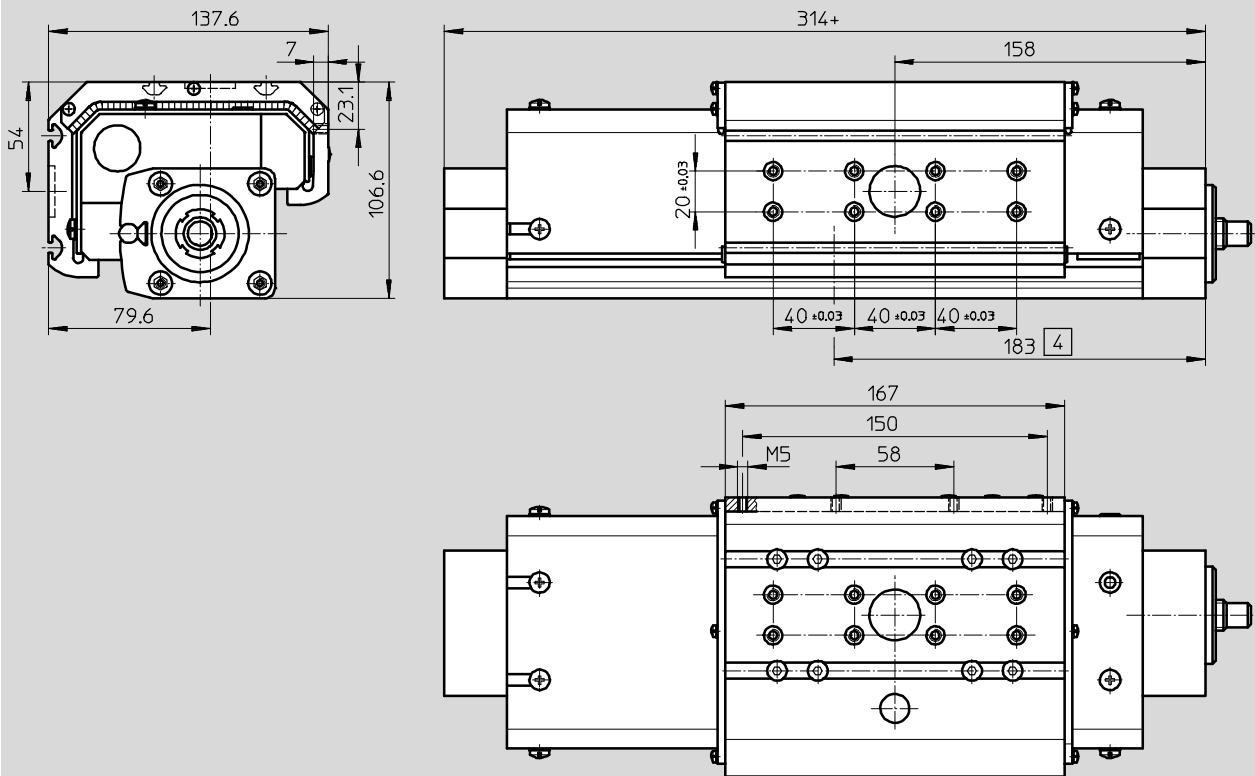

4 Lubrication opening
+ = plus stroke length

Positioning axes DMES-GF/-KF, with guide

Ordering data – Modular products



Order processing for positioning axis DMES in combination with intelligent motor unit MTR-DCI

1 Ordering positioning axis DMES [Ordering table → 40](#)

The drive unit and corresponding accessories are configured in the ordering table for the positioning axis DMES.

The code "AX" or "U" is used to specify whether an intelligent motor unit MTR-DCI and an axial or a parallel kit are required for the positioning axis.

The motor unit design must be defined separately.

Modulcode	Motorcode	Stirn	Stirn	Stirn	Stirn	Stirn	Stirn	Stirn	Stirn	Stirn	Stirn	Stirn	Stirn
533 649	DMES	25	25	25	25	25	25	25	25	25	25	25	25
533 700	DMES	40	40	40	40	40	40	40	40	40	40	40	40
533 704	DMES	63	63	63	63	63	63	63	63	63	63	63	63
533 706	DMES	63	63	63	63	63	63	63	63	63	63	63	63

3 Ordering intelligent motor unit MTR-DCI [Ordering table → LEERER MERKER](#)

The motor unit order code determined from table 2 must now be completed with the "gear unit" and "parameterisation interface" codes.

The module number of the intelligent motor unit must not be specified when ordering with order code "AX" or "U". It is determined automatically.

Modulcode	Motorcode	Stirn	Stirn	Stirn	Stirn	Stirn	Stirn	Stirn	Stirn	Stirn	Stirn	Stirn	Stirn
533 649	DMES	25	25	25	25	25	25	25	25	25	25	25	25
533 700	DMES	40	40	40	40	40	40	40	40	40	40	40	40
533 704	DMES	63	63	63	63	63	63	63	63	63	63	63	63
533 706	DMES	63	63	63	63	63	63	63	63	63	63	63	63

Modulcode	Motorcode	Stirn	Stirn	Stirn	Stirn	Stirn	Stirn	Stirn	Stirn	Stirn	Stirn	Stirn	Stirn
533 649	DMES	25	25	25	25	25	25	25	25	25	25	25	25
533 700	DMES	40	40	40	40	40	40	40	40	40	40	40	40
533 704	DMES	63	63	63	63	63	63	63	63	63	63	63	63
533 706	DMES	63	63	63	63	63	63	63	63	63	63	63	63

Modulcode	Motorcode	Stirn	Stirn	Stirn	Stirn	Stirn	Stirn	Stirn	Stirn	Stirn	Stirn	Stirn	Stirn
533 649	DMES	25	25	25	25	25	25	25	25	25	25	25	25
533 700	DMES	40	40	40	40	40	40	40	40	40	40	40	40
533 704	DMES	63	63	63	63	63	63	63	63	63	63	63	63
533 706	DMES	63	63	63	63	63	63	63	63	63	63	63	63

2 Permissible combinations with intelligent motor unit MTR-DCI

Positioning axis	Motor unit
DMES-18-...	MTR-DCI-32S-VCSC-E...
DMES-25-...	MTR-DCI-42S-VCSC-E...
DMES-40-...	MTR-DCI-52S-VCSC-E...
DMES-63-...	MTR-DCI-62S-VDSC-E...

4 Order example

Part No.	Type
	Positioning axis DMES
533 700	DMES-25-700-KF-GK-SH-AX;ZUB-2S2Y1M1F
	Intelligent motor unit MTR-DCI
-	MTR-DCI-42S-VCSC-EG7-R210

Note
Servo, stepper motors and the corresponding mounting kits must be ordered separately → 42

Positioning axes DMES-GF/-KF, with guide

Ordering data – Modular products

Order code

Mandatory data

DMES-...-GK

DMES-...-GV

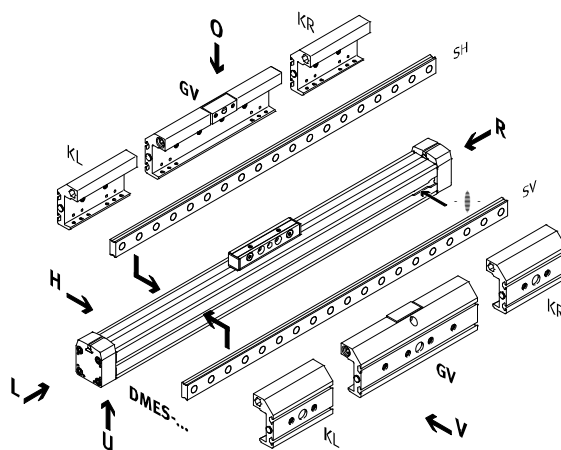
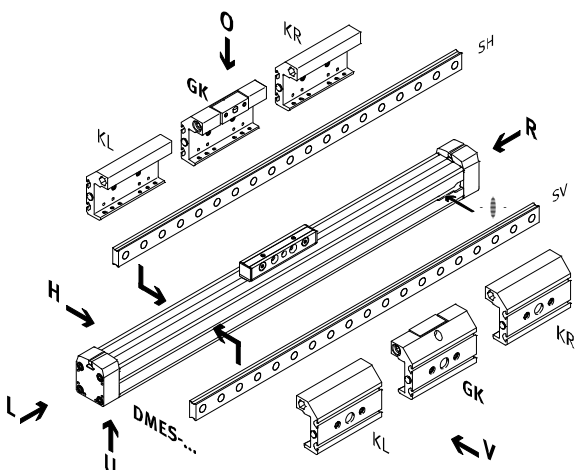

- Note
The insertion point for the proximity sensor is located on the right-hand side of the positioning axis.

O top
U underneath
V front
H rear
R right
L left

Order code

Options

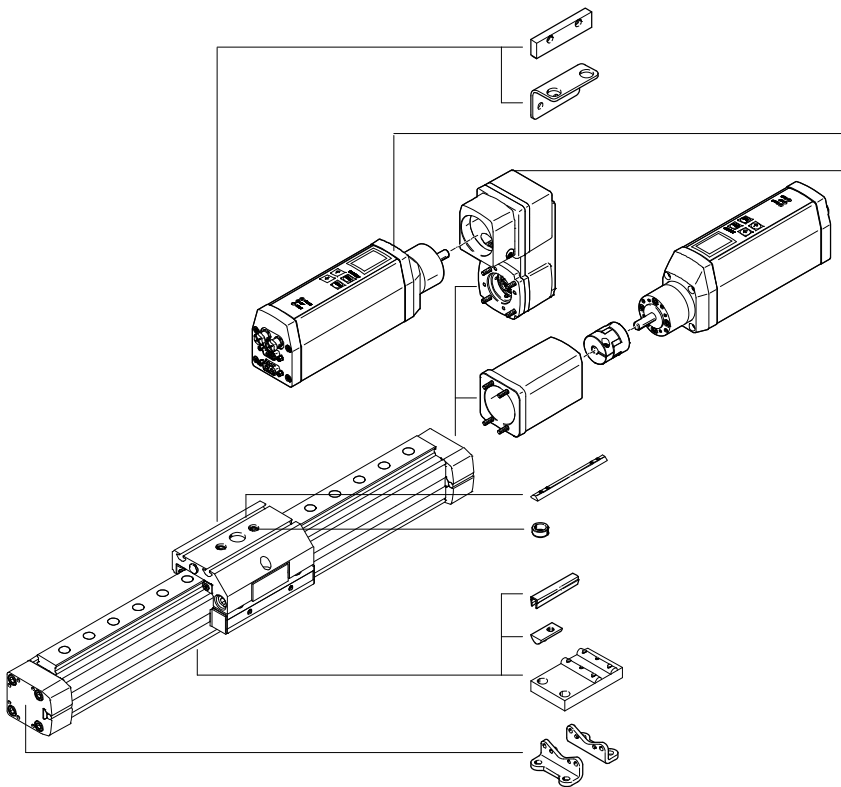

- L
- T
- Motor unit
- Parallel kit
- Motor unit
- Axial kit
- X
- Z
- B/S
- Y
- M
- F

Positioning axes DMES-GF/-KF, with guide

Ordering data – Modular products



M Mandatory data			O Options					
Module No.	Function	Stroke	Guide		Slide attachment position		Motor unit	Accessories
	Size		Slide		Additional slide			Accessories supplied loose
533699	DMES 18	50 ... 1,800	GF	GK	SV	KL	AX	...S, ...B, ...Y, ...X, ...M, ...F, ...Z, ...T, L
533700	25		KF	GV	SH	KR	U	
533701	40			GA				
533702	63							
Order example								
533701	DMES	- 40	- 800	- KF	- GV	- SV	- KL	- : ZUB - 2X2M20Z
MTR-DCI-...S-VCSC-E...-...IO								

Ordering table								
Size	18	25	40	63	Condi- tions	Code	Enter code	
M Module No.	533699	533700	533701	533702				
Function	Positioning axis with slide					DMES		DMES
Size	18	25	40	63		- ...		
Stroke [mm]	50 ... 400	50 ... 700	50 ... 1,200	50 ... 1,800		- ...		
O Guide	Plain-bearing guide				1	-GF		
	Recirculating ball bearing guide				1	-KF		
Slide	Standard slide				2	-GK		
	Extended slide				2	-GV		
	Protected version				2	-GA		
Slide attachment position	Slide at front				2	-SV		
	Slide at rear				2	-SH		
Additional slide	Additional slide, standard, at left				3	-KL		
	Additional slide, standard, at right				3	-KR		
Motor unit	Axial kit and motor unit (enclosed separately)				4	-AX		
	Parallel kit and motor unit (enclosed separately)				4	-U		
Accessories	Supplied separately					:ZUB-		:ZUB-
Slot cover	Sensor slot	1 ... 10				...S		
	Mounting slot	-	1 ... 10			...B		
Slot nut	Mounting slot	1 ... 10				...Y		
	Slide	-	1 ... 10		2	...X		
Central support	1 ... 10					...M		
Foot mounting	1 ... 10					...F		
Centring sleeve (pack of 10)	10 ... 90				2	...Z		
Mounting bracket for inductive proximity sensors	1 ... 5				5	...T		
Switching lug	1				5	L		

1 GF, KF Only with slide GK, GV or GA and with slide attachment position SV or SH.

2 GK, GV, GA, SV, SH, X, Z Only with guide GF or KF

3 KL, KR Only with guide KF (recirculating ball bearing guide) and with slide GK or GV

4 AX, U Order processing for intelligent motor unit MTR-DCI → LEERER MERKER

5 T, L Only with slide GK or GV

Transfer order code

	DMES	-		-		-		-		-		-		:	ZUB	-	
MTR-DCI-...S-VCSC-E...-...IO																	

Positioning axes DMES

Accessories – Motor units MTR-DCI



M Mandatory data										
Module No.	Motor unit		Flange/size		Nominal voltage		Measuring system		Parameterisation interface	
Order example	Motor type		Torque class		Plug design		Gearing unit		Electrical connection technology	
	MTR	DCI	32 42 52 62	S	VC VD	SC	E	G7 G14 G22	R2 H2	IO CO PB DN
	533 742	MTR	- DCI	- 42	S	- VC	SC	- E	G7	- R2

Ordering table											
Size	32	42	52	62	Condi- tions	Code	Enter code				
M] Module No.	533 736				533 754						
Motor unit	Motor unit						MTR	MTR			
Motor type	DC servo motor with integrated position controller						-DCI	-DCI			
Flange/size	32	42	52	62	-...	S	S				
Torque class	Standard torque class						S	S			
Nominal voltage	M] 24 DC				-	-VC					
	M] -				48 DC	-VD					
Plug design	Straight plug						SC	SC			
Measuring system	Encoder						-E	-E			
Gearing unit	Integrated planetary gearing i = 6.75						G7				
	Integrated planetary gearing i = 13.73						G14				
					Integrated planetary gearing i = 22.21		G22				
Parameterisation interface	RS232 interface						-R2				
	RS232 interface + control panel						-H2				
Electrical connection technology	I/O interface						IO				
	CANopen						CO				
	Profibus DP						PB				
	DeviceNet						DN				

Transfer order code



	MTR	-	DCI		S		SC	-	E		-		-	
--	------------	---	------------	--	----------	--	-----------	---	----------	--	---	--	---	--

PROFIBUS®, DeviceNet®, CANopen® is a registered trademark of its respective trademark holder in certain countries.

Positioning axes DMES

Accessories

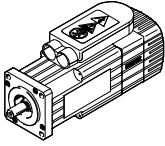
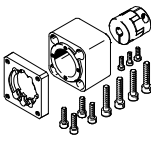
FESTO

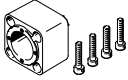
Permissible axis/motor combinations with axial kit – Without gear unit					Technical data → Internet: eamm-a
Motor unit	Axial kit	Axial kit consisting of:			
		Motor flange	Coupling	Coupling housing	
					
Type	Part No. Type	Part No. Type	Part No. Type	Part No. Type	
DMES-18					
With servo motor					
EMMS-AS-40-...	550961 EAMM-A-E20-40A	552163 EAMF-A-28B-40A	540751 EAMC-B-15-22-5-6	170374 EAMK-A-E20-28B	
EMMS-AS-55-...	550963 EAMM-A-E20-55A	529946 EAMF-A-28A/B-55A	529953 EAMC-B-15-22-5-9	170374 EAMK-A-E20-28B	
With stepper motor					
EMMS-ST-42-...	550962 EAMM-A-E20-42A	552164 EAMF-A-28B-42A	530085 EAMC-B-15-22-5-5	170374 EAMK-A-E20-28B	
With motor unit					
MTR-DCI-32S-...	556991 EAMM-A-E20-32B	–	533707 EAMC-15-20-5-6	533703 EAMK-A-E20-32B	
DMES-25					
With servo motor					
EMMS-AS-40-...	550964 EAMM-A-E32-40A	550985 EAMF-A-44A/B-40A	123040 EAMC-30-35-6-6	124631 EAMK-A-E32-44A	
EMMS-AS-55-...	550965 EAMM-A-E32-55A	529942 EAMF-A-44A/B-55A	530941 EAMC-30-35-6-9	124631 EAMK-A-E32-44A	
With stepper motor					
EMMS-ST-57-...	550966 EAMM-A-E32-57A	530081 EAMF-A-44A/B-57A	530087 EAMC-30-35-6-6.35	124631 EAMK-A-E32-44A	
With motor unit					
MTR-DCI-42S-...G7	556992 EAMM-A-E32-42B	–	533708 EAMC-30-32-6-8	533704 EAMK-A-E32-42B	
MTR-DCI-42S-...G14	556993 EAMM-A-E32-42C	–	533708 EAMC-30-32-6-8	538578 EAMK-A-E32-42C	

-  - Note



At ambient temperatures below room temperature, the frictional torques increase in the case of the DMES-...-GF (plain-bearing guide). Depending on the combination of motor/motor unit and positioning axis, it may not be possible to reach the maximum feed force of the axis.

The following tool is available for sizing:
PositioningDrives
sizing software
→ www.festo.com

Positioning axes DMES

Accessories

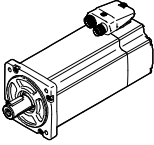
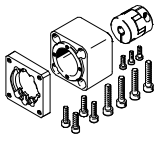
FESTO

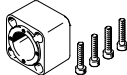
Permissible axis/motor combinations with axial kit – Without gear unit				Technical data → Internet: eamm-a
Motor/motor unit	Axial kit	Axial kit consisting of:		
		Motor flange	Coupling	Coupling housing
				
Type	Part No. Type	Part No. Type	Part No. Type	Part No. Type
DMES-40				
With servo motor				
EMMS-AS-55-...	550969 EAMM-A-E48-55A	529942 EAMF-A-44A/B-55A	550996 EAMC-30-35-9-12	124632 EAMK-A-E48-44A
EMMS-AS-70-...	557448 EAMM-A-E48-64A-70A	529945 EAMF-A-64A/B-70A	525864 EAMC-40-66-11-12	529940 EAMK-A-E48-64A
EMME-AS-100-...	550973 EAMM-A-E48-100A	529947 EAMF-A-64A/C/D-100A	529952 EAMC-40-66-12-19	529940 EAMK-A-E48-64A
EMMS-AS-100-...	550973 EAMM-A-E48-100A	529947 EAMF-A-64A/C/D-100A	529952 EAMC-40-66-12-19	529940 EAMK-A-E48-64A
With stepper motor				
EMMS-ST-57-...	550970 EAMM-A-E48-57A	530081 EAMF-A-44A/B-57A	550995 EAMC-30-35-6.35-12	124632 EAMK-A-E48-44A
EMMS-ST-87-...	550972 EAMM-A-E48-87A	533140 EAMF-A-64A/B-87A	525864 EAMC-40-66-11-12	529940 EAMK-A-E48-64A
With motor unit				
MTR-DCI-52S-...-G7	556994 EAMM-A-E48-52B	–	533709 EAMC-42-50-12-12	533705 EAMK-A-E48-52B
MTR-DCI-52S-...-G14	556995 EAMM-A-E48-52C	–	533709 EAMC-42-50-12-12	538579 EAMK-A-E48-52C
DMES-63				
With servo motor				
EMMS-AS-70-...	550975 EAMM-A-E72-70A	529945 EAMF-A-64A/B-70A	550999 EAMC-40-66-11-20	529941 EAMK-A-E72-64A
EMME-AS-100-...	550978 EAMM-A-E72-100A	529947 EAMF-A-64A/C/D-100A	132847 EAMC-40-66-19-20	529941 EAMK-A-E72-64A
EMMS-AS-100-...	550978 EAMM-A-E72-100A	529947 EAMF-A-64A/C/D-100A	132847 EAMC-40-66-19-20	529941 EAMK-A-E72-64A
With stepper motor				
EMMS-ST-87-...	550977 EAMM-A-E72-87A	533140 EAMF-A-64A/B-87A	550999 EAMC-40-66-11-20	529941 EAMK-A-E72-64A
With motor unit				
MTR-DCI-62S-...	556996 EAMM-A-E72-62B	–	533710 EAMC-42-50-14-20	533706 EAMK-A-E72-62B

 Note



At ambient temperatures below room temperature, the frictional torques increase in the case of the DMES-...-GF (plain-bearing guide). Depending on the combination of motor/motor unit and positioning axis, it may not be possible to reach the maximum feed force of the axis.

The following tool is available for sizing:
PositioningDrives
sizing software
→ www.festo.com

Positioning axes DMES

Accessories

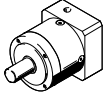
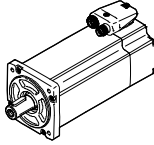
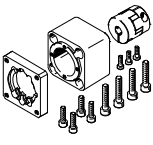
FESTO

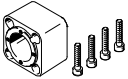
Permissible axis/motor combinations with axial kit – With gear unit						Technical data → Internet: eamm-a
Gear unit	Motor	Axial kit	Axial kit consisting of:			
			Motor flange	Coupling	Coupling housing	
						
Type	Type	Part No. Type	Part No. Type	Part No. Type	Part No. Type	
DMES-40						
With servo motor						
EMGA-40-P-G...-EAS-40	EMME-AS-40-...	550968 EAMM-A-E48-40G	550986 EAMF-A-44A/B-40G	552640 EAMC-30-35-10-12	124632 EAMK-A-E48-44A	
EMGA-40-P-G...-SAS-40	EMMS-AS-40-...	550968 EAMM-A-E48-40G	550986 EAMF-A-44A/B-40G	552640 EAMC-30-35-10-12	124632 EAMK-A-E48-44A	
DMES-63						
With servo motor						
EMGA-60-P-G...-SAS-70	EMMS-AS-70-...	550974 EAMM-A-E72-60G	550987 EAMF-A-64A/B-60G	550999 EAMC-40-66-11-20	529941 EAMK-A-E72-64A	
EMGA-80-P-G...-SAS-70	EMMS-AS-70-...	550976 EAMM-A-E72-80G	533139 EAMF-A-64A/C-80G	123849 EAMC-40-66-20-20	529941 EAMK-A-E72-64A	
EMGA-80-P-G...-EAS-80	EMME-AS-80-...	550976 EAMM-A-E72-80G	533139 EAMF-A-64A/C-80G	123849 EAMC-40-66-20-20	529941 EAMK-A-E72-64A	
EMGA-80-P-G...-SAS-100	EMME-AS-100-...	550976 EAMM-A-E72-80G	533139 EAMF-A-64A/C-80G	123849 EAMC-40-66-20-20	529941 EAMK-A-E72-64A	
EMGA-80-P-G...-SAS-100	EMMS-AS-100-...	550976 EAMM-A-E72-80G	533139 EAMF-A-64A/C-80G	123849 EAMC-40-66-20-20	529941 EAMK-A-E72-64A	
With stepper motor						
EMGA-80-P-G...-SST-87	EMMS-ST-87-...	550976 EAMM-A-E72-80G	533139 EAMF-A-64A/C-80G	123849 EAMC-40-66-20-20	529941 EAMK-A-E72-64A	

 - Note

At ambient temperatures below room temperature, the frictional torques increase in the case of the DMES-...-GF (plain-bearing guide). Depending on the combination of motor/motor unit and positioning axis, it may not be possible to reach the maximum feed force of the axis.

The following tool is available for sizing:
PositioningDrives
sizing software
→ www.festo.com

Positioning axes DMES

Accessories

FESTO

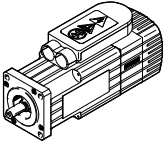
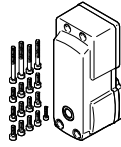
Permissible axis/motor combinations with parallel kit – Without gear unit		Technical data → Internet: eamm-u	
Motor/motor unit	Parallel kit		
			
Type	Part No.	Type	
DMES-18			
With servo motor			
EMMS-AS-40-...	543 226	EAMM-U-E24-40A	
With motor unit			
MTR-DCI-32S-...	543 225	EAMM-U-E24-32B	
DMES-25			
With servo motor			
EMMS-AS-55-...	543 230	EAMM-U-E32-55A	
With motor unit			
MTR-DCI-42S-...-G7	543 228	EAMM-U-E32-42B	
MTR-DCI-42S-...-G14	543 229	EAMM-U-E32-42C	
DMES-40			
With servo motor			
EMMS-AS-70-...	543 234	EAMM-U-E48-70A	
With motor unit			
MTR-DCI-52S-...-G7	543 232	EAMM-U-E48-52B	
MTR-DCI-52S-...-G14	543 233	EAMM-U-E48-52C	

 Note

At ambient temperatures below room temperature, the frictional torques increase in the case of the DMES-...-GF (plain-bearing guide). Depending on the combination of motor/motor unit and positioning axis, it may not be possible to reach the maximum feed force of the axis. The respective no-load driving torque of the kit must be taken into consideration when using parallel kits.

The following tool is available for sizing:
PositioningDrives
sizing software
→ www.festo.com

Positioning axes DMES

Accessories



Foot mounting HP (order code F)

Material:
Galvanised steel
Free of copper, PTFE and silicone



HP-25

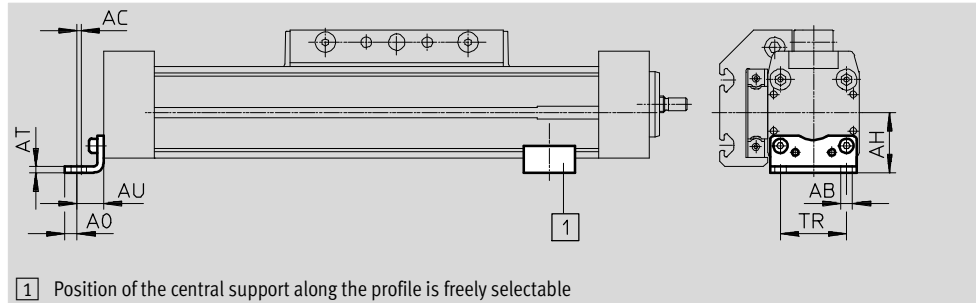

Dimensions and ordering data											
For size	AB ∅	AC	AH	AO	AT	AU	TR	Weight [g]	Part No.	Type	
18	5.5	2	24	4.8	3	13.2	24	59	158 472	HP-18	
25	5.5	2	29.5	6	3	13	32.5	61	150 731	HP-25	
40	6.6	2	46	8.5	5	17.5	45	188	150 733	HP-40	
63	11	3	69	13.5	6	28	75	305	150 735	HP-63	

Central support MUP (order code M)

Material:
Galvanised steel
Free of copper, PTFE and silicone



MUP-40

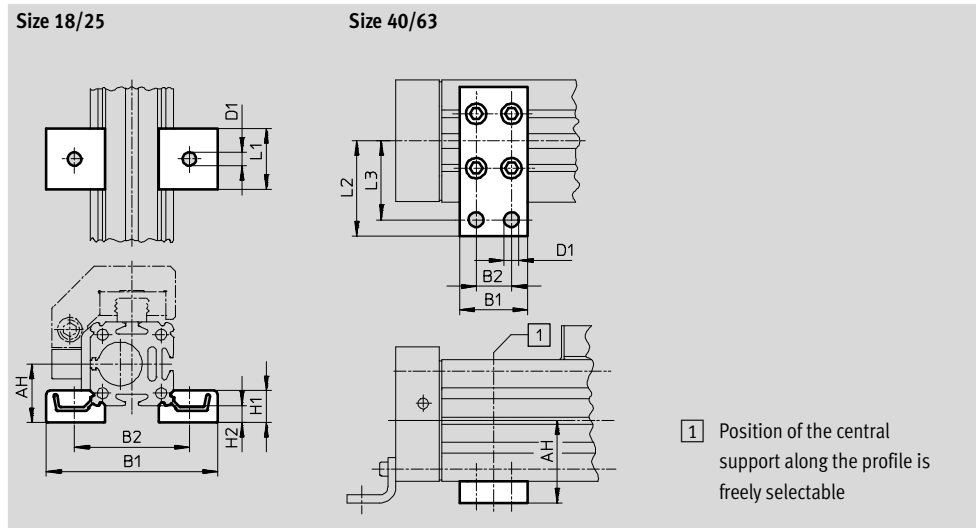

Dimensions and ordering data												
For size	AH	B1	B2	D1 ∅	H1	H2	L1	L2	L3	Weight [g]	Part No.	Type
18	24	70.5	47	5.5	13	7	25	-	-	33	150 736	MUP-18/25
25	29.5	81	58	5.5	13	7	25	-	-	33	150 736	MUP-18/25
40	46	35	22	6.6	-	-	-	47	40	126	150 738	MUP-40
63	69	50	26	11	-	-	-	77	65	340	150 800	MUP-63

Positioning axes DMES

Accessories



Sensor bracket HWS

for inductive proximity sensors
(order code T)

Material:
Galvanised steel



Switch lug SF

(order code L)

Material:
Galvanised steel



Size 18/25

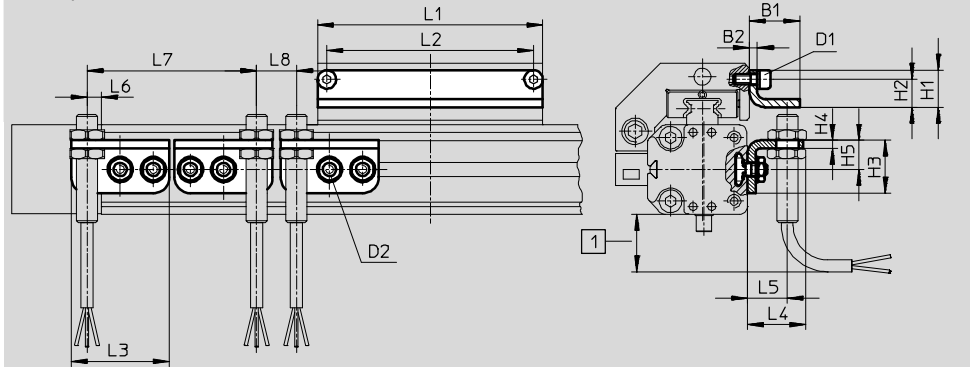

Size 40/63

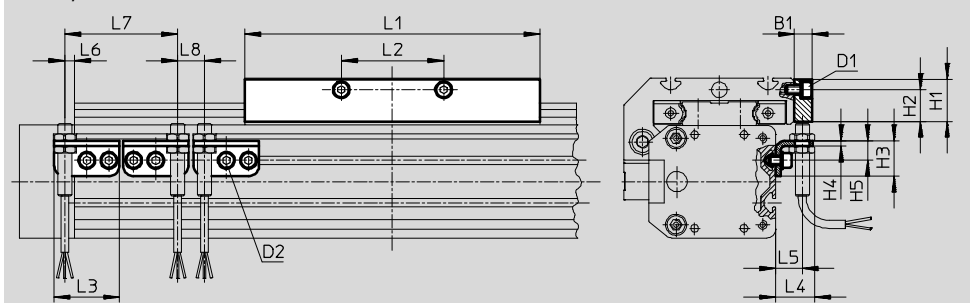

1 Protruding sensor cable, ensure sufficient installation space

Dimensions and ordering data





For size	D1	D2	B1	B2	H1	H2	H3	H4	H5	L1	L2	L3	L4	L5
18	M4	M5	19	3	14	10.5	20	3	11	85	78	37	22.5	15
25	M5	M5	27	3	20.5	15.3	20	3	11	105	88	37	34.5	27
40	M5	M5	10	-	24	18	20	3	11	167	58	37	22.5	15
63	M8	M5	10	-	35	25	20	3	11	230	72	37	22.5	15

For size	L6 max.	L7 min.	L8 min.	Weight [g]	Part No.	Type
18	5.5	64	15	34	188 968	HWS-18/25-M8
				59	188 964	SF-18
25	5.5	64	15	34	188 968	HWS-18/25-M8
				75	188 965	SF-25
40	5.5	64	15	37	188 969	HWS-40-M8
				328	188 966	SF-40
63	5.5	64	15	45	188 970	HWS-63-M8
				630	188 967	SF-63

Positioning axes DMES

Accessories

FESTO

Ordering data – Inductive proximity sensors M8						Technical data → Internet: sien	
	Electrical connection		Switching output	LED	Cable length [m]	Part No.	Type
	Cable	Plug M8					
N/O contact							
	3-wire	–	PNP	■	2.5	150 386	SIEN-M8B-PS-K-L
	–	3-pin	PNP	■	–	150 387	SIEN-M8B-PS-S-L
N/C contact							
	3-wire	–	PNP	■	2.5	150 390	SIEN-M8B-PO-K-L
	–	3-pin	PNP	■	–	150 391	SIEN-M8B-PO-S-L

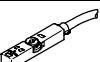



Ordering data – Proximity sensors for T-slot, magneto-resistive					Technical data → Internet: smt		
	Type of mounting	Switching output	Electrical connection	Cable length [m]	Part No.	Type	
N/O contact							
	Insertable in the slot lengthwise, flush with the cylinder profile, short design	PNP	Plug M8x1, 3-pin	0.3	574334	SMT-8M-A-PS-24V-E-0,3-M8D	
			Cable, 3-wire	2.5	574335	SMT-8M-A-PS-24V-E-2,5-OE	

Ordering data – Connecting cable				Technical data → Internet: km8			
	Assembly	Connection	Cable length [m]	Part No.	Type		
Straight socket							
	Union nut M8, both ends	3-pin	0.5	175 488	KM8-M8-GSGD-0,5		
			1	175 489	KM8-M8-GSGD-1		
			2.5	165 610	KM8-M8-GSGD-2,5		
			5	165 611	KM8-M8-GSGD-5		

Positioning axes DMES

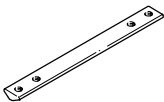
Accessories



Ordering data				Technical data → Internet: mounting attachment		
	For size	Comment	Order code	Part No.	Type	PU ¹⁾
Slot nut NST						
	18/25	For mounting slot	Y	526 091	NST-HMV-M4	10
	40			150 914	NST-5-M5	1
	63			150 915	NST-8-M6	1
Slot nut NSTL						
	25	For slide	X	158 410	NSTL-25	1
	40			158 412	NSTL-40	1
	63			158 414	NSTL-63	1
Centring pin ZBS/centring sleeve ZBH						
	18	For slide	Z	150 928	ZBS-5	10
	25/40/63			150 927	ZBH-9	10
Slot cover ABP						
	40	For mounting slot every 0.5 m	B	151 681	ABP-5	2
	63			151 682	ABP-8	2
Slot cover ABP-S						
	18/25/40/63	For sensor slot every 0.5 m	S	151 680	ABP-5-S	2

1) Packaging unit