

Linear drive units DGO



# Linear drive units DGO

Features

FESTO



## General information

- Double-acting
- Magnetically coupled without mechanical connections
- Piston chamber and slide are pressure tight
- Pressure tight and leak-free system
- Dirt and dust cannot enter
- Space-saving installation with long strokes
- For contactless position sensing
- With adjustable end-position cushioning at both ends (not for piston  $\varnothing$  of 12 mm)

## The technology in detail

Motion is transmitted via the force locking of the magnetic coupling on the moveable outer slide.

This means that there is no advancing piston rod; the installation space required is less than for conventional pneumatic cylinders.

The cylinder chamber is hermetically sealed against the outer slide as there is no mechanical connection. This prevents any leakage loss.

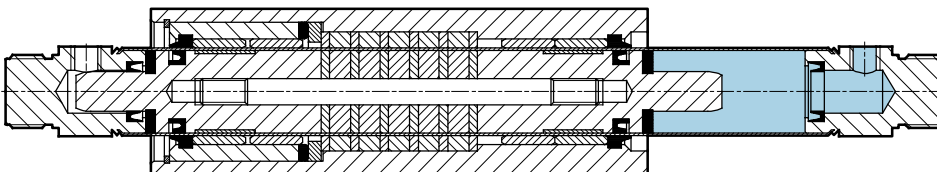

# Linear drive units DGO

Peripherals overview

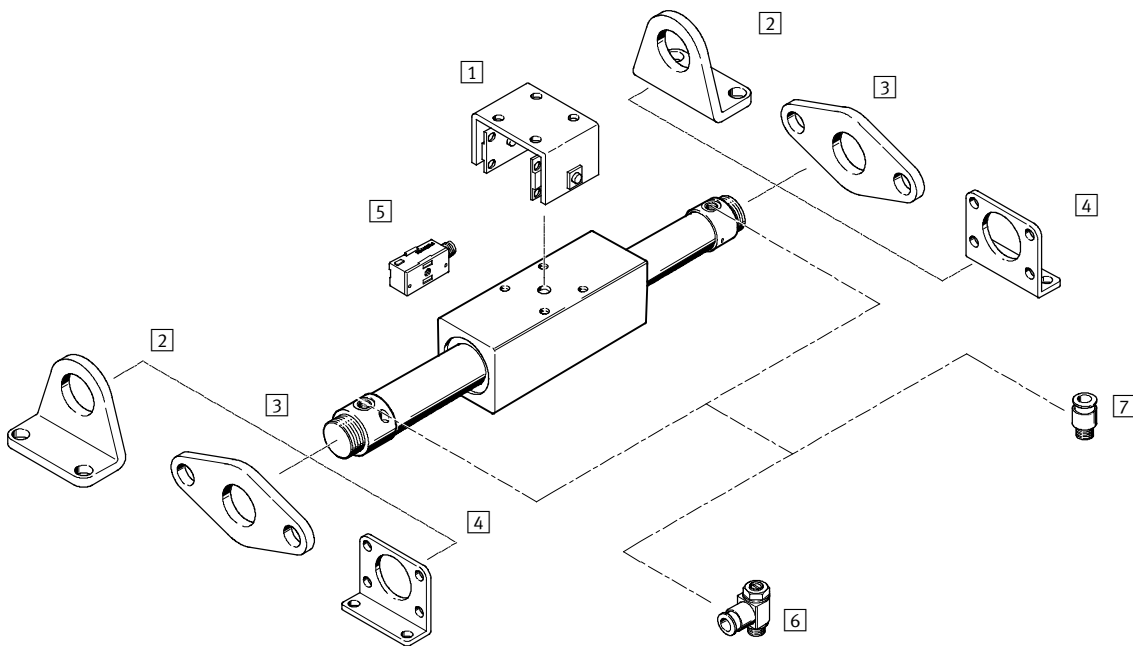

## Mounting options

With hexagonal nuts (included in scope of delivery)

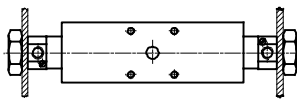

## With mounting attachments

Foot mounting HBN

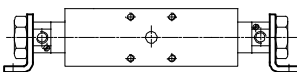

Flange mounting

FBN

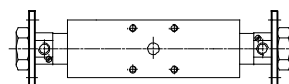
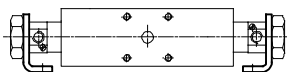

## Mounting attachments and accessories

	Brief description	→ Page/Internet
1 Moment compensator FKG	To compensate misalignments and eliminate tilting moments	10
2 Foot mounting HBN	On end caps for piston $\varnothing$ 12 ... 25 mm	10
3 Flange mounting FBN	On end caps for piston $\varnothing$ 12 ... 25 mm	11
4 Flange mounting FBN	On end caps for piston $\varnothing$ 32 ... 40 mm	11
5 Proximity sensors SMEO-/SMTO-/SMPO-1	For contactless position sensing, mountable externally via a mounting kit	12
6 One-way flow control valve GRLA	To regulate speed	12
7 Push-in fitting QS	For connecting compressed air tubing with standard external diameters	quick star

# Linear drive units DGO

Type codes

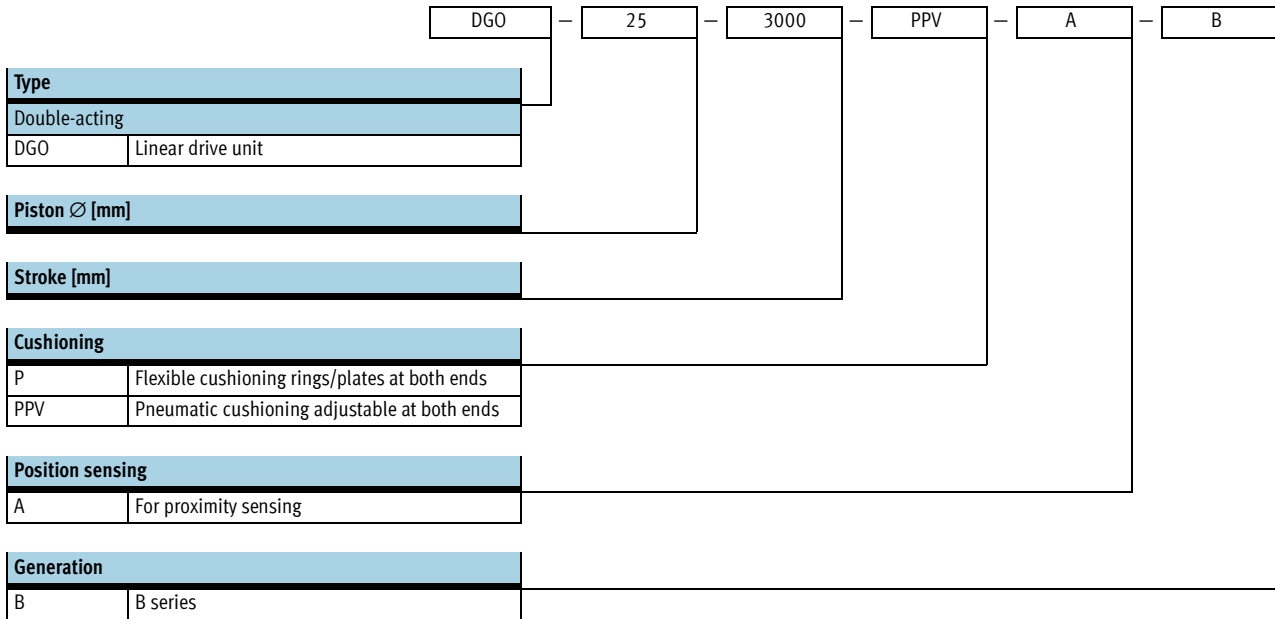

# Linear drive units DGO

Technical data

Function

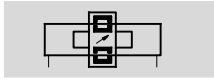

-  $\varnothing$  - Diameter  
12 ... 40 mm

- | - Stroke length  
10 ... 4,000 mm

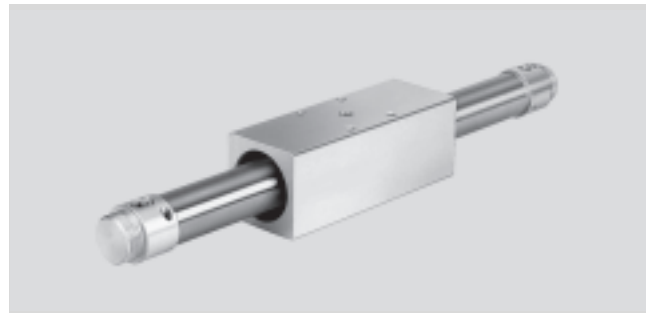

General technical data						
Piston $\varnothing$	12	16	20	25	32	40
Stroke [mm]	10 ... 1,200	10 ... 2,500	10 ... 3,000	10 ... 3,500		10 ... 4,000
Pneumatic connection	M5		G1/8		G1/4	
Operating medium	Compressed air in accordance with ISO 8573-1:2010 [7:-:-]					
Note on operating/pilot medium	Operation with lubricated medium possible (in which case lubricated operation will always be required)					
Design	Rodless					
Driver principle	Force-locking (magnetic)					
Cushioning	Flexible cushioning rings/plates at both ends		Pneumatic cushioning adjustable at both ends			
Cushioning length [mm]	-	14	17	19	20	23
Position sensing	For proximity sensing					
Type of mounting	With hexagonal nuts					
	With accessories					
Fitting position	Any					

Operating and environmental conditions						
Piston $\varnothing$	12	16	20	25	32	40
Operating pressure [bar]	2 ... 7	1.7 ... 7	1.6 ... 7	1.5 ... 7	1.4 ... 7	1.3 ... 7
Temperature range <sup>1)</sup> [°C]	-20 ... +60					

1) Note operating range of proximity sensors

Forces [N]						
Piston $\varnothing$	12	16	20	25	32	40
Theoretical force at 6 bar	68	121	188	295	483	754
Breakaway force of the magnetic coupling	100	160	270	400	680	1,050

Weights [g]						
Piston $\varnothing$	12	16	20	25	32	40
Product weight with 0 mm stroke	320	620	1,000	1,340	2,400	3,920
Additional weight per 10 mm stroke	2	3	4	4.8	6	8

# Linear drive units DGO

Technical data

## Materials

Sectional view

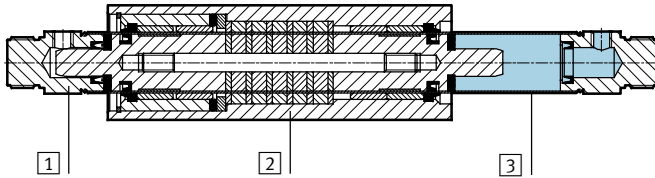

## Linear drive unit

1	End cap	Anodised aluminium
2	Outer slide	Anodised aluminium
3	Cylinder barrel	High-alloy steel
-	Seals	Nitrile rubber, polyurethane

## Permissible axial force F dependent on lever arm A

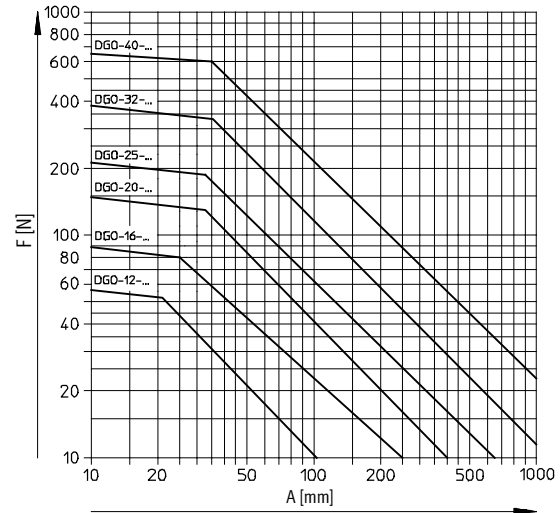
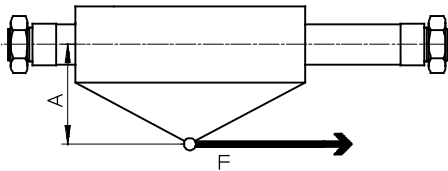

## Permissible lateral force $F_q$ dependent on stroke length L

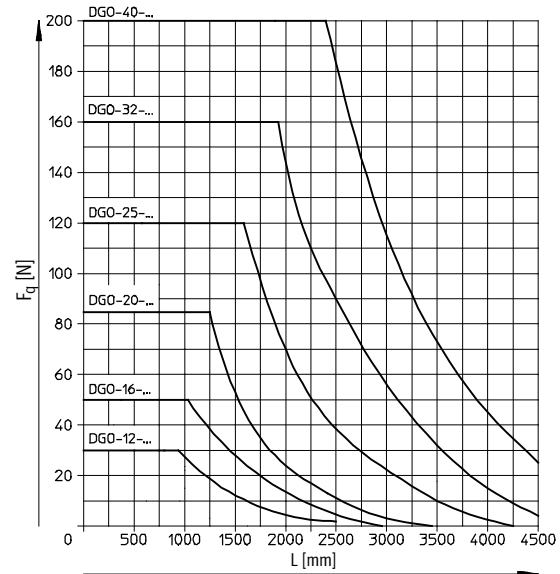
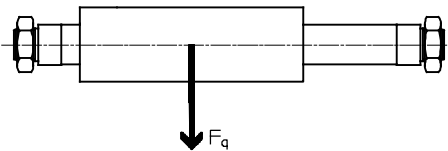

# Linear drive units DGO

Technical data

## Max. piston speed $v$ dependent on the moving mass $m$

If the operating conditions are outside the permissible range, the moving mass must be externally cushioned using suitable equipment (shock absorbers or stops).

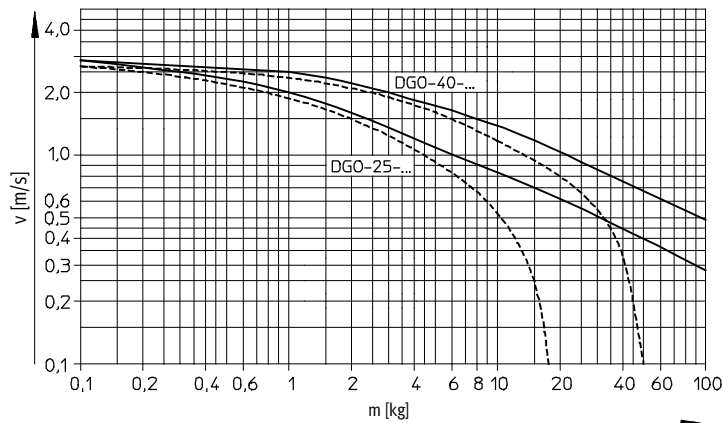
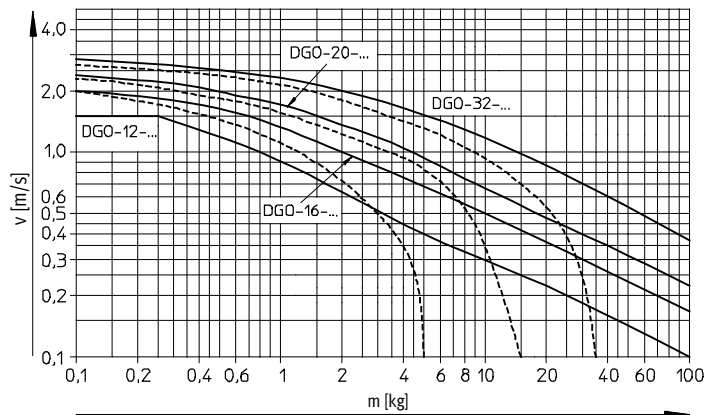

— Horizontal mounting position  
 - - - - - Vertical mounting position

## Contactless position sensing

Mounting the proximity sensors SMEO-/SMT0-/SMPO-1

The proximity sensors are fitted by the user near the linear drive unit (e.g. on a  $\varnothing 6$  mm rod). Contactless position sensing is only possible in the area shown. Too small a distance  $A$  can cause multiple switching.

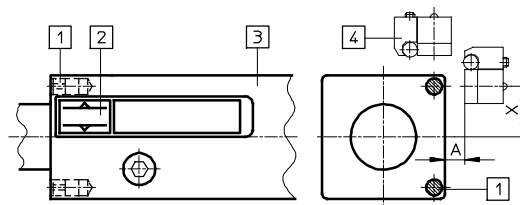

- 1 Switching magnet for proximity sensor
- 2 Switching range
- 3 Outer slide 360° rotatable
- 4 Proximity sensor with mounting kit SMB-1

## Switching distances, switching travel and hysteresis [mm]

Proximity sensors	A	X						Switching travel	Hysteresis
		DGO-12-...	DGO-18-...	DGO-20-...	DGO-25-...	DGO-32-...	DGO-40-...		
SMEO-1, SMT0-1	6.0 ... 8.0	10 ... 11	13 ... 14	16 ... 17	20 ... 21	25 ... 26	32 ... 33	7.5 ... 13	1.0 ... 4.5
SMPO-1-H-B	5.0 ... 6.0							7.0 ... 15	0.4 ... 2.5

# Linear drive units DGO

Technical data

FESTO

## Dimensions

Download CAD data → [www.festo.com](http://www.festo.com)

Piston Ø12 mm

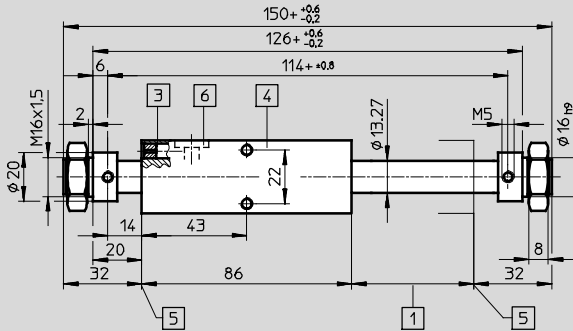

- 1 Stroke length
  - 3 Switching magnet for proximity sensor
  - 4 Outer slide 360° rotatable
  - 5 End-position
  - 6 Lubrication nipple
  - 7 Mounting kit for proximity sensor
- + = plus stroke length

Piston Ø16... 25 mm

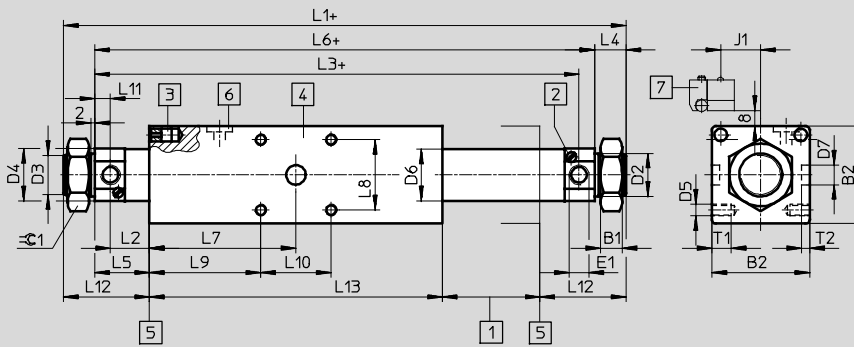

- 1 Stroke length
  - 2 Regulating screw for adjustable end-position cushioning
  - 3 Switching magnet for proximity sensor
  - 4 Outer slide 360° rotatable
  - 5 End-position
  - 6 Lubrication nipple
  - 7 Mounting kit for proximity sensor
- + = plus stroke length

Piston Ø32... 40 mm

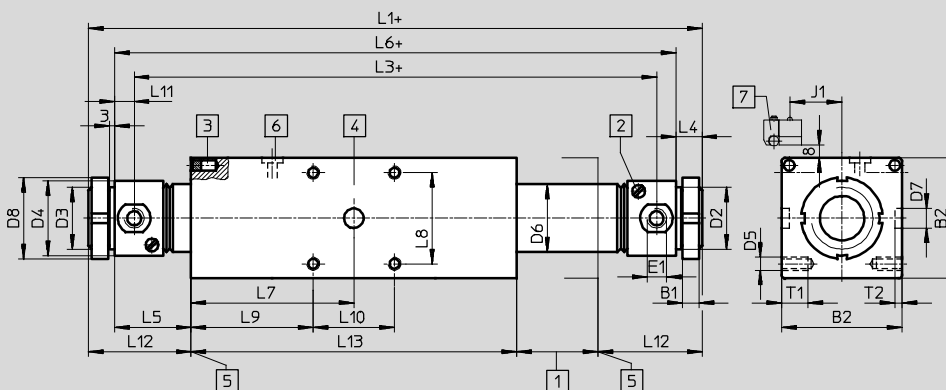

- 1 Stroke length
  - 2 Regulating screw for adjustable end-position cushioning
  - 3 Switching magnet for proximity sensor
  - 4 Outer slide 360° rotatable
  - 5 End-position
  - 6 Lubrication nipple
  - 7 Mounting kit for proximity sensor
- + = plus stroke length



# Linear drive units DGO

Technical data

Dimensions									
∅	B1	B2	D2	D3	D4	D5	D6	D7	D8
[mm]			∅ h9		∅		∅	∅ h8	∅
16	8	36	16	M16x1.5	20	M5	17.5	8	–
20	11	42	22	M22x1.5	27	M5	21.3	8	–
25	11	50	22	M22x1.5	27	M6	26.5	10	–
32	8	60	30	M30x1.5	38	M6	33.6	10	42
40	10	74	38	M38x1.5	46	M8	42.6	12	50

∅	E1	J1	L1	L2	L3	L4	L5	L6	L7
[mm]									
16	M5	13.5	205 +1/-0.5	12	149 +1/-0.5	12	28	181 ±0.6	62.5
20	G1/8	16.5	217 +0.8/-0.6	16.5	169 +1/-0.8	16	24.5	185 +0.8/-0.6	67.5
25	G1/8 <sup>1)</sup>	20.5	238 +1.3/-0.7	20	190 +1.5/-0.9	16	28	206 +1.3/-0.7	75
32	G1/8	25.5	270 +0.8/-0.6	23.6	218 +0.8/-0.6	16	33.6	238 +0.8/-0.6	85
40	G1/4	32	327 +1.3/-0.7	35	271 +1.5/-0.9	16	47	295 +1.3/-0.7	100

∅	L8	L9	L10	L11	L12	L13	T1	T2	≈G1
[mm]									
16	26	49.5	26	16	40	125	8	4	24
20	32	51.5	32	8	40.5	135	10	3	32
25	36	57	36	8	44	150	10	4	32
32	48	61	48	10	49.5	170	12.5	4	–
40	56	75	50	12	63	200	16	4.5	–

1) Max. screw-in depth 7 mm. Use screws supplied by Festo: → [www.festo.com](http://www.festo.com)

Ordering data			
∅	Stroke	Part No.	Type
[mm]	[mm]		
12	10 ... 1,200	15 221	DGO-12-...-P-A-B
16	10 ... 2,500	15 222	DGO-16-...-PPV-A-B
20	10 ... 3,000	15 223	DGO-20-...-PPV-A-B
25	10 ... 3,500	15 224	DGO-25-...-PPV-A-B
32	10 ... 3,500	15 225	DGO-32-...-PPV-A-B
40	10 ... 4,000	15 226	DGO-40-...-PPV-A-B

# Linear drive units DGO

Accessories



## Moment compensator FKG

for piston  $\varnothing$  16 ... 40 mm  
Maximum permissible misalignment of parallel guide in longitudinal axis of cylinder = 1 mm.

Scope of delivery: 1 moment compensator and 8 mounting screws

Material:  
Galvanised steel

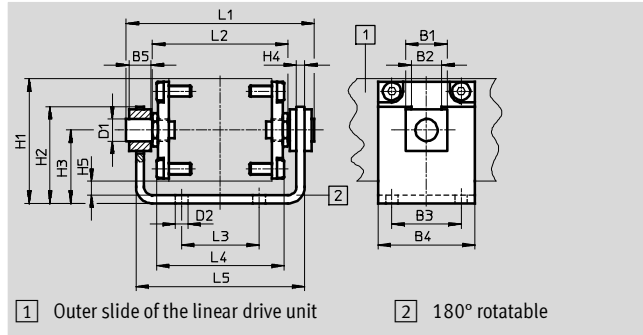
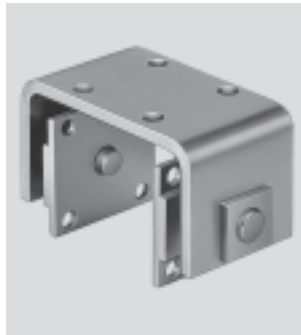

Dimensions and ordering data																					
For $\varnothing$	B1	B2	B3	B4	B5	D1 $\varnothing$	D2 $\varnothing$	H1	H2	H3	H4	H5	L1	L2	L3	L4	L5	CRC <sup>1)</sup>	Weight [g]	Part No.	Type
16	18	14	26	40	8	10	5.5	47	40	29	4	7	74	54	26	49	68	2	257	15 233	FKG-16-B
20	18	14	32	42	8	10	5.5	53	43	32	4	7	82	62	32	57	76	2	302	33 339	FKG-20-B
25	22	16	36	50	12	12	6.6	63	50	38	5	8	98	70	36	64	89	2	511	15 234	FKG-25-B
32	22	16	48	60	12	12	6.6	73	55	43	5	8	108	80	48	74	99	2	677	33 340	FKG-32-B
40	30	22	50	70	16	16	9	90	70	53	6	10	134	98	56	92	122	2	1,277	15 235	FKG-40-B

1) Corrosion resistance class 2 according to Festo standard 940 070  
Components requiring moderate corrosion resistance. Externally visible parts with primarily decorative surface requirements which are in direct contact with a surrounding industrial atmosphere or media such as cooling or lubricating agents.

## Foot mounting HBN

for piston  $\varnothing$  12 ... 25 mm

Material:  
Galvanised steel  
Free of copper, PTFE and silicone

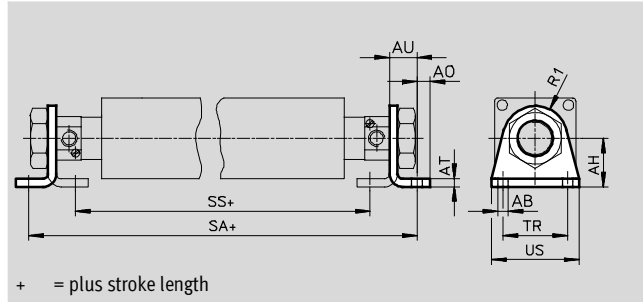
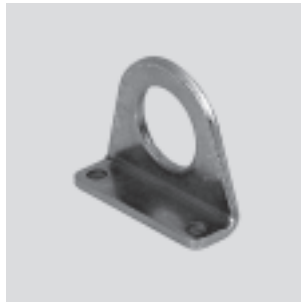

Dimensions and ordering data														
For $\varnothing$	AB $\varnothing$	AH	AO	AT	AU	R1	SA	SS	TR	US	CRC <sup>1)</sup>	Weight [g]	Part No.	Type
12	5.5	20	6	4	14	13	153	105	32	42	2	40	5 125	HBN-12/16x1
16	5.5	27	6	4	14	13	209	161	32	42	2	50	6 062	HBN-12/16x1-A
20	6.6	30	8	5	17	20	219	161	40	54	2	100	6 064	HBN-20/25x1-A
25	6.6	30	8	5	17	20	240	182	40	54	2	100	6 064	HBN-20/25x1-A

1) Corrosion resistance class 2 according to Festo standard 940 070  
Components requiring moderate corrosion resistance. Externally visible parts with primarily decorative surface requirements which are in direct contact with a surrounding industrial atmosphere or media such as cooling or lubricating agents.

# Linear drive units DGO

Accessories

**Flange mounting FBN**  
for piston  $\varnothing$  12 ... 25 mm

Material:  
Galvanised steel  
Free of copper, PTFE and silicone

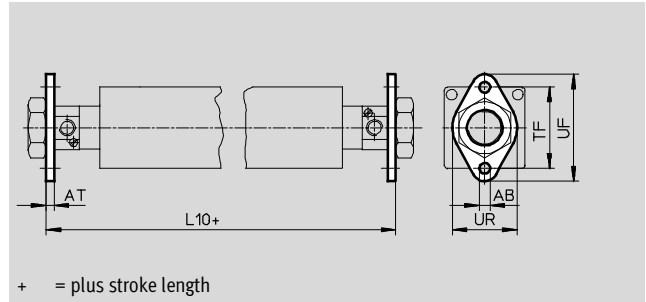

Dimensions and ordering data												
For $\varnothing$	AB $\varnothing$	AT	L10	TF	UF	UR	US	CRC <sup>1)</sup>	Weight [g]	Part No.	Type	
12	5.5	4	133	40	53	30	42	2	26	5 130	FBN-12/16	
16	5.5	4	189	40	53	30	42	2	26	5 130	FBN-12/16	
20	6.6	5	189	50	66	40	54	2	52	5 131	FBN-20/25	
25	6.6	5	216	50	66	40	54	2	52	5 131	FBN-20/25	

1) Corrosion resistance class 2 according to Festo standard 940 070  
Components requiring moderate corrosion resistance. Externally visible parts with primarily decorative surface requirements which are in direct contact with a surrounding industrial atmosphere or media such as cooling or lubricating agents.

**Flange mounting FBN**  
for piston  $\varnothing$  32 ... 40 mm

Material:  
Galvanised steel  
Free of copper, PTFE and silicone

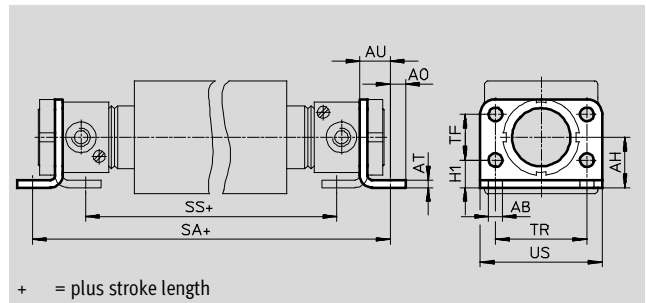

Dimensions and ordering data															
For $\varnothing$	AB $\varnothing$	AH	AO	AT	AU	H1	SA	SS	TF	TR	US	CRC <sup>1)</sup>	Weight [g]	Part No.	Type
32	7	28	7	4	14	14	266	218	28	52	66	2	102	195 855	FBN-32
40	9	33	10	5	19	18	335	265	30	60	80	2	190	195 856	FBN-40

1) Corrosion resistance class 2 according to Festo standard 940 070  
Components requiring moderate corrosion resistance. Externally visible parts with primarily decorative surface requirements which are in direct contact with a surrounding industrial atmosphere or media such as cooling or lubricating agents.

# Linear drive units DGO

Accessories



**FESTO**

Ordering data – Rectangular proximity sensors, magneto-resistive						Technical data → Internet: smto	
	Mounting	Switch output	Electrical connection		Cable length [m]	Part No.	Type
			Cable	M8 plug			
NO contact							
	With accessories	PNP	3-wire	–	2.5	151 683	SMTO-1-PS-K-LED-24-C
			–	3-pin	–	151 685	SMTO-1-PS-S-LED-24-C
		NPN	3-wire	–	2.5	151 684	SMTO-1-NS-K-LED-24-C
			–	3-pin	–	151 686	SMTO-1-NS-S-LED-24-C

Ordering data – Rectangular proximity sensors, magnetic reed						Technical data → Internet: smeo	
	Mounting	Electrical connection		Cable length [m]	Part No.	Type	
		Cable	M8 plug				
NO contact							
	With accessories	3-wire	–	2.5	30 459	SMEO-1-LED-24-B	
		3-wire	–	5.0	151 672	SMEO-1-LED-24-K5-B	
		–	3-pin	–	150 848	SMEO-1-S-LED-24-B	

Ordering data – Rectangular proximity sensors, pneumatic					Technical data → Internet: smpo	
	Mounting	Pneumatic connection		Part No.	Type	
3/2-way valve, normally closed						
	With accessories	Barbed fitting for 3 mm tubing ID		31 008	SMPO-1-H-B	

Ordering data – Mounting kit				Technical data → Internet: smb	
	Mounting			Part No.	Type
	For cylinder with tie rod $\varnothing$ 6 mm or DUO rail mounting profile			11 886	SMB-1

Ordering data – Connecting cables					Technical data → Internet: nebu	
	Electrical connection, left	Electrical connection, right	Cable length [m]	Part No.	Type	
	Straight socket, M8x1, 3-pin	Cable, open end, 3-wire	2.5	541 333	NEBU-M8G3-K-2.5-LE3	
			5	541 334	NEBU-M8G3-K-5-LE3	
	Angled socket, M8x1, 3-pin	Cable, open end, 3-wire	2.5	541 338	NEBU-M8W3-K-2.5-LE3	
			5	541 341	NEBU-M8W3-K-5-LE3	

Ordering data – One-way flow control valves				Technical data → Internet: grla	
	Connection		Material	Part No.	Type
	Thread	For tubing OD			
	M5	3	Metal design	193 137	GRLA-M5-QS-3-D
		4		193 138	GRLA-M5-QS-4-D
	G $\frac{1}{8}$	4		193 143	GRLA- $\frac{1}{8}$ -QS-4-D
		6		193 144	GRLA- $\frac{1}{8}$ -QS-6-D
	G $\frac{1}{4}$	6		193 146	GRLA- $\frac{1}{4}$ -QS-6-D
		8		193 147	GRLA- $\frac{1}{4}$ -QS-8-D