

Passive guide axes DGC-FA, without drive



Passive guide axes DGC-FA, without drive

Key features

At a glance

- Driveless linear guide units with guide and freely movable slide
- The passive guide axis is designed to support force and torque capacity in multi-axis applications
- Higher torsional resistance
- Reduced vibrations with dynamic loads
- Drive axis and passive guide axis can be placed adjacent to or above one another

System product for handling and assembly technology

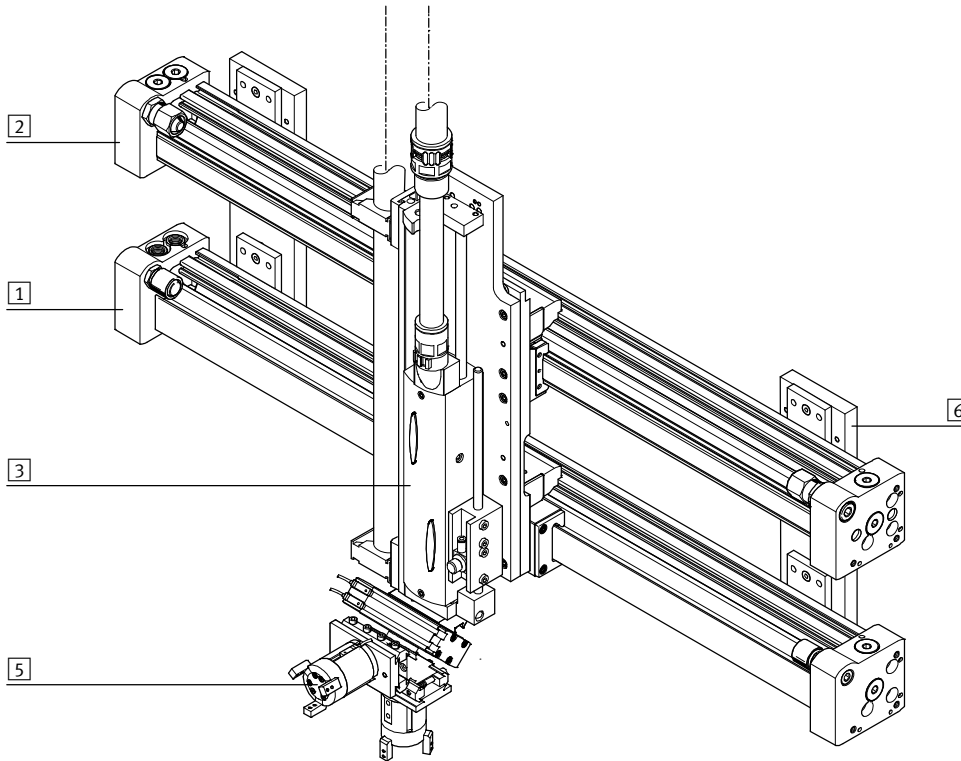

System components and accessories

Type/Order code	Description	→ Page/Internet
1 Axes	Wide range of combinations possible within handling and assembly technology	axis
2 Passive guide axes	For supporting force and torque capacity in multi-axis applications	passive guide axis
3 Drives	Wide range of combinations possible within handling and assembly technology	drive
5 Grippers	Wide range of variations possible within handling and assembly technology	gripper
6 Adapters	For drive/drive and drive/gripper connections	adapter kit
- Motors	Servo and stepper motors, with or without gear unit	motor

Passive guide axes DGC-FA, without drive

Key features

Guide axes and the corresponding drives

Passive guide axis DGC-FA



- Can be combined with:
 - Linear drive DGC-KF
- For size 8 ... 63
- Load capacity to max. 6890 N or 380 Nm

Passive guide axis EGC-FA



- Can be combined with:
 - Toothed belt axis EGC-TB
 - Spindle axis EGC-BS
- For size 70 ... 185
- Load capacity to max. 15200 N or 1820 Nm

Passive guide axis FDG-ZR-RF



- Can be combined with:
 - Toothed belt axis DGE-ZR-RF
- For size 25 ... 63
- Load capacity to max. 1500 N or 600 Nm

Passive guide axis FDG-P/-ZR/-SP



- Can be combined with:
 - Linear drive DGPL
 - Toothed belt axis DGE-ZR-KF
 - Spindle axis DGE-SP-KF
- For size 18 ... 63
- Load capacity to max. 14050 N or 1820 Nm

Options

Central lubrication – C

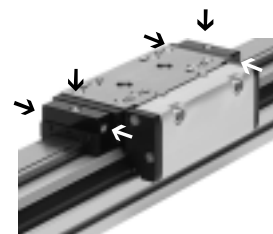

The lubrication adapter enables the guide of the passive guide axis DGC-FA to be permanently lubricated in applications in humid or wet ambient conditions using semi or fully automatic relubrication devices. The adapters are suitable for oils and greases.

- For piston \varnothing 25, 32, 40, 63 mm
- Connections:
 - On both sides of the slide
 - In three places (front, top, rear) on each side

Technical data → 13

Clamping unit – 1H-PN



- 1-channel design, for holding loads
 - Reliable holding is guaranteed since the forces act directly on the slide
 - A limited number of emergency braking operations are permissible with the sizes 40 and 50
- For piston \varnothing 25, 32, 40, 50 mm

Technical data → 10

Passive guide axes DGC-FA, without drive

Peripherals overview



-  - Note
 1) End stops or shock absorbers must not be removed.

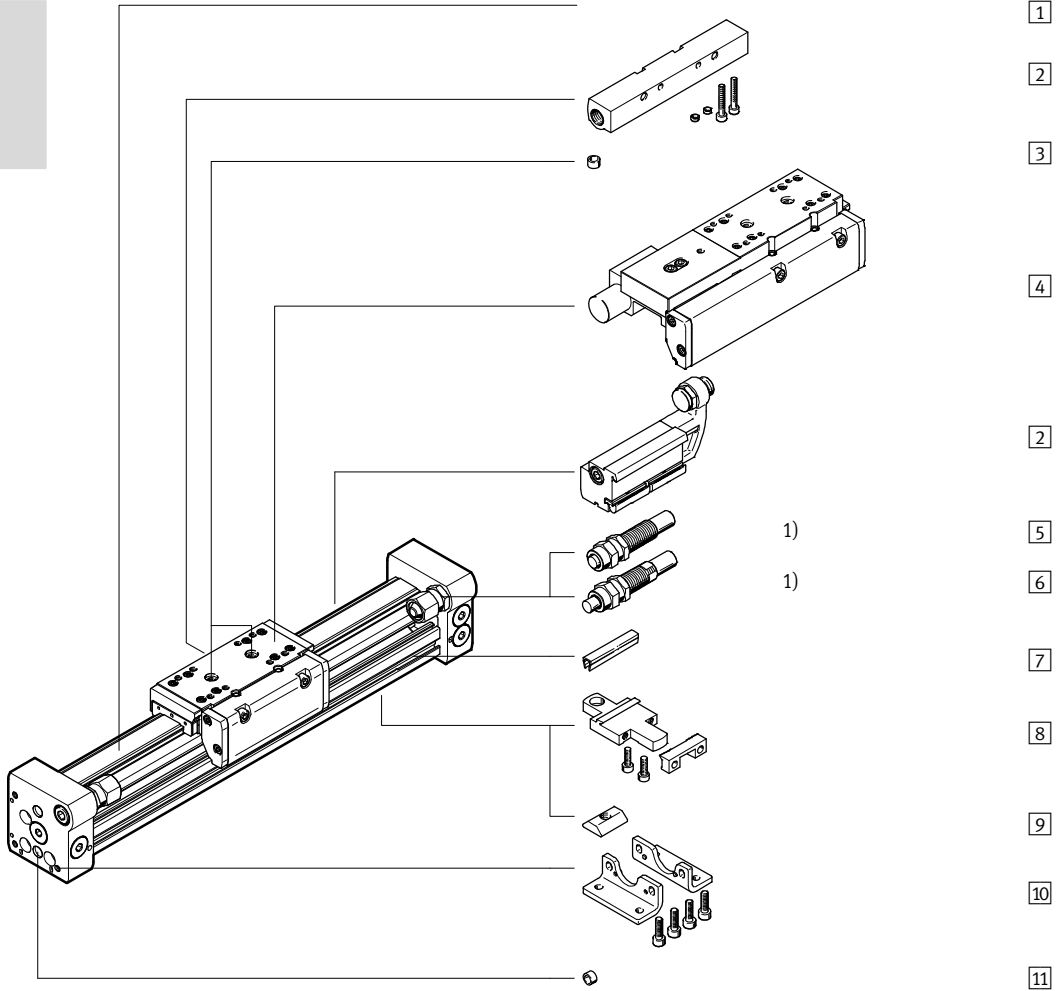

Passive guide axes DGC-FA, without drive

Peripherals overview

Variants and accessories			
	Type/Order code	Description	→ Page/Internet
1	Passive guide axis DGC-FA	Passive guide axis without accessories	6
2	Mechanical end-position limiter YWZ	For variable end-position adjustment, e.g. for format adjustments	30
3	Centring pin/sleeve ¹⁾ ZBS/ZBH	For centring loads and attachments on the slide	32
4	Clamping unit 1H-PN	For holding loads	10
-	Cushioning P	Non-adjustable, flexible cushioning. Only used for low speeds	27
5	Shock absorber YSR	Self-adjusting hydraulic shock absorber with spring return and linear cushioning characteristics	27
6	Shock absorber YSRW	Self-adjusting hydraulic shock absorber with spring return and progressive cushioning characteristics	27
7	Slot cover L	For protecting against ingress of dirt and securing proximity sensor cables	32
8	Profile mounting M	Simple and precise mounting option via dovetail connection	29
9	Slot nut B	For mounting attachments	32
10	Foot mounting F	For mounting on end cap	28
11	Centring pin/sleeve ¹⁾ ZBS/ZBH	For centring the drive DGC without foot mountings (user-specific)	32

1) Included in the scope of delivery of the axis

Passive guide axes DGC-FA, without drive

Type codes

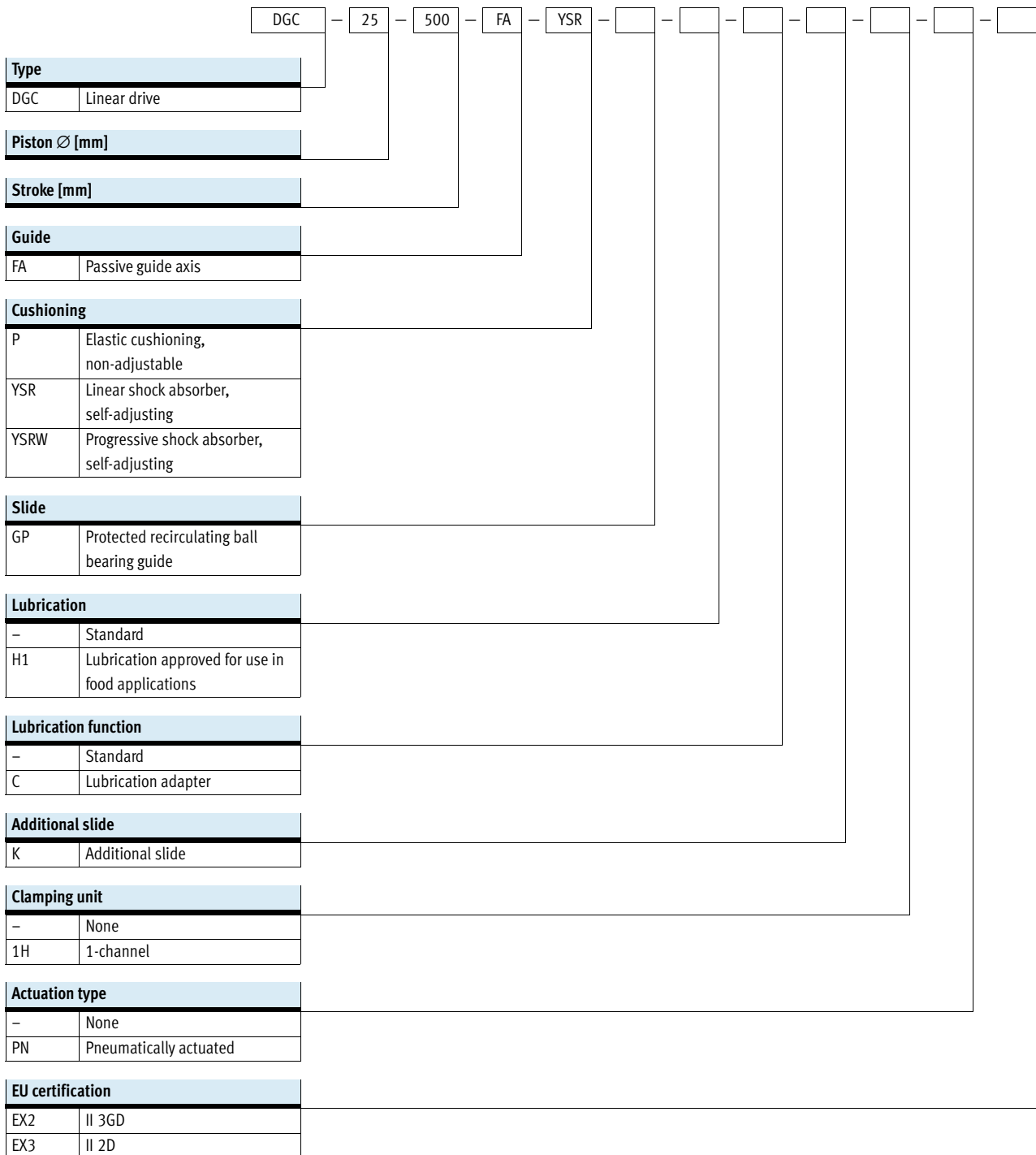

Passive guide axes DGC-FA, without drive

Type codes

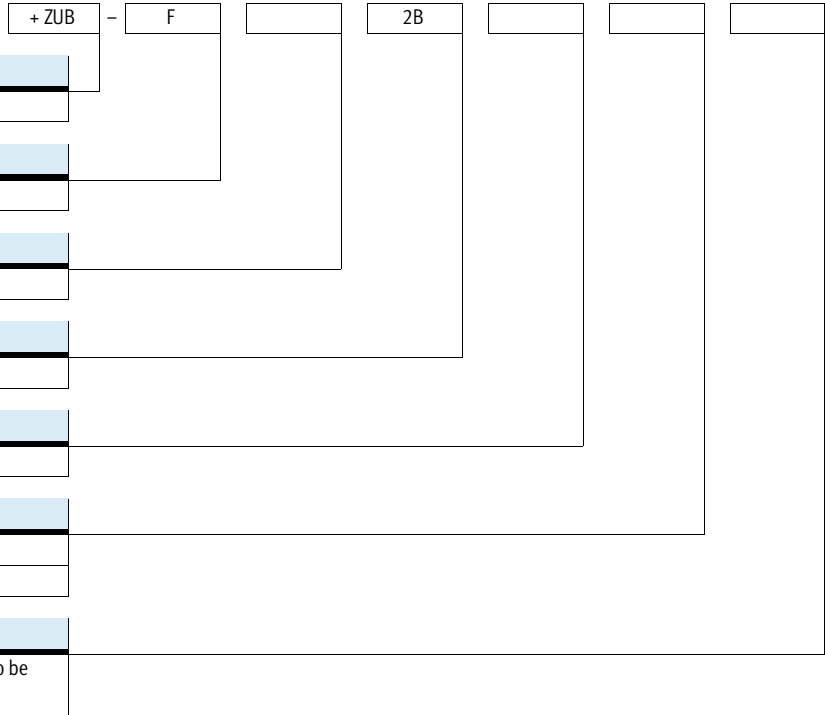

Accessories

ZUB	Accessories supplied loose
-----	----------------------------

Foot mounting

F	Foot mounting
---	---------------

Profile mounting

...M	Profile mounting
------	------------------

Slot nut

...B	For mounting slot
------	-------------------

Slot cover

...L	For sensor slot
------	-----------------

Mechanical end position limiter

YWZ1	Variable end position, at one end
YWZ2	Variable end position, at both ends

User manual

0	Express waiver – no operating instructions to be included
---	---



Passive guide axes DGC-FA, without drive

FESTO

Technical data

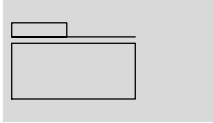
Function



-  - Diameter
8 ... 63 mm
-  - Stroke length
1 ... 8500 mm

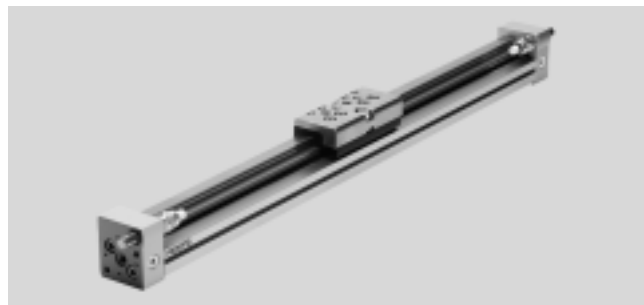

General technical data								
Piston \varnothing	8	12	18	25	32	40	50	63
Stroke [mm]	1 ... 1300		1 ... 1900		1 ... 3000		1 ... 8500	
Guide	External recirculating ball bearing guide							
Mounting position	Any							
Cushioning \rightarrow 11								
DGC-...-P	Non-adjustable at both ends							
DGC-...-YSR...	Self-adjusting at both ends							
Type of mounting	Profile mounting							
	Foot mounting							
	Direct mounting							
Max. speed [m/s]	1	1.2	3					
Repetition accuracy [mm]	0.02 (with shock absorber YSR/YSRW)							

Operating and environmental conditions	
Ambient temperature [°C]	-10 ... +60
Corrosion resistance class CRC ¹⁾	1

- 1) Corrosion resistance class CRC 1 to Festo standard FN 940070
Low corrosion stress. For dry indoor applications or transport and storage protection. Also applies to parts behind covers, in the non-visible interior area, and parts which are covered in the application (e.g. drive trunnions).

ATEX ¹⁾		
Size	8	12 ... 63
Explosion-proof temperature rating	+5°C \leq Ta \leq +60°C	
CE marking (see declaration of conformity)	As per EU Explosion Protection Directive (ATEX)	
EX2 certification		
ATEX category for gas	II 3G	
Explosion ignition protection type for gas	c T4 X	
ATEX category for dust	II 3D	
Explosion ignition protection type for dust	c T120°C X	
EX3 certification		
ATEX category for gas	II 2G	
Explosion ignition protection type for gas	c T4 X	

- 1) Note the ATEX certification of the accessories.

Passive guide axes DGC-FA, without drive

Technical data

Weight [g]								
Piston Ø	8	12	18	25	32	40	50	63
DGC-...								
Basic weight with 0 mm stroke	225	391	975	2113	2837	6996	13342	22220
Additional weight per 10 mm stroke	11	16	31	49	74	117	153	236
Moving load	77	149	331	732	1146	2330	4511	8225
DGC-...-1H-PN – With clamping unit								
Basic weight with 0 mm stroke	–	–	–	3134	4272	12009	19394	–
Additional weight per 10 mm stroke	–	–	–	49	74	117	153	–
Moving load	–	–	–	1405	2059	5494	8411	–

Adjustable end-position range d [mm]

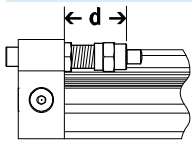

Piston Ø	8	12	18	25	32	40	50	63
Cushioning								
DGC-...-P/PPV	11.3 ... 16.3	12.7 ... 17.7	13.8 ... 15.8	21.1 ... 25.1	25.2 ... 30.2	28.7 ... 33.7	28.7 ... 33.7	38.8 ... 43.8
DGC-...-P/PPV-GP	–	–	16.9 ... 18.9	23.6 ... 27.6	25.2 ... 30.2	34.7 ... 39.7	–	–
DGC-...-YSR/YSRW	12.8 ... 22.8	14 ... 24	14.5 ... 34.5	22.5 ... 47.5	27.3 ... 52.3	31 ... 56	31 ... 56	41 ... 76

Materials

Sectional view

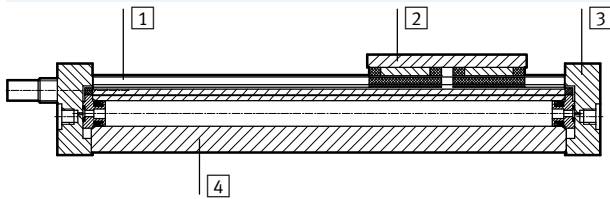

Passive guide axes		
1	Guide rail	High-alloy steel
2	Slide	High-alloy steel
3	End cap	Anodised aluminium
4	Cylinder barrel	Anodised aluminium
–	Sealing band	Polyurethane
Note on materials		RoHS-compliant

Passive guide axes DGC-FA, without drive

Technical data

FESTO

Characteristic load values

The indicated forces and torques refer to the centre of the slide surface.

These values must not be exceeded during dynamic operation. Special attention must be paid to the cushioning phase.

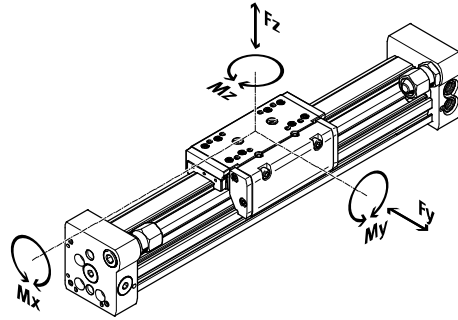

If the drive is simultaneously subjected to several of the indicated forces and torques, the following equation must be satisfied in addition to the indicated maximum loads:

$$\frac{F_y}{F_{y_{max}}} + \frac{F_z}{F_{z_{max}}} + \frac{M_x}{M_{x_{max}}} + \frac{M_y}{M_{y_{max}}} + \frac{M_z}{M_{z_{max}}} \leq 1$$

Permissible forces and torques

Piston Ø		8	12	18	25	32	40	50	63
F _y _{max.}	[N]	300	650	1850	3050	3310	6890	6890	15200
F _z _{max.}	[N]	300	650	1850	3050	3310	6890	6890	15200
M _x _{max.}	[Nm]	1.7	3.5	16	36	54	144	144	529
M _y _{max.}	[Nm]	4.5	10	51	97	150	380	634	1157
M _z _{max.}	[Nm]	4.5	10	51	97	150	380	634	1157

Technical data – Clamping unit

Size		25	32	40	50
Pneumatic connection		M5	M5	M5	M5
Clamping type		Clamping via spring force, released via compressed air			
Static holding force	[N]	320	500	1200	1200
Max. number of emergency braking operations ¹⁾ at reference energy	[Nm]	–	–	750 35	750 35
Number of clamping operations under nominal load	[million switching cycles]	0.45	0.55	0.05	0.05

1) Emergency braking refers to braking the effective load if the drive axis loses power.

Operating and environmental conditions – Clamping unit

Operating medium		Compressed air according to ISO 8573-1:2010 [7:4:4]
Operating pressure		
Clamping unit opened	[bar]	4.5 ... 8
Clamping unit closed	[bar]	Pressureless
Ambient temperature	[°C]	–10 ... +60

Passive guide axes DGC-FA, without drive

Technical data

Maximum permissible piston speed v as a function of effective load m and distance r_{max} from centre of gravity of load

Piston \varnothing 8/12 with P cushioning

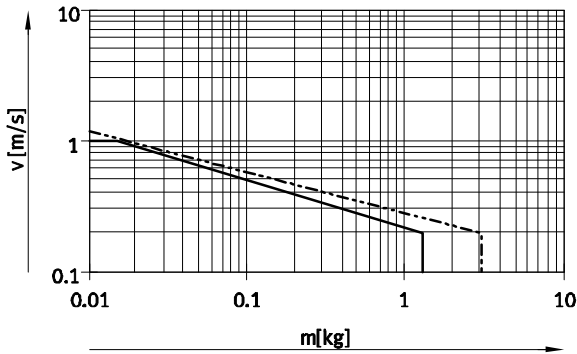

Piston \varnothing 8 ... 40 with YSR cushioning

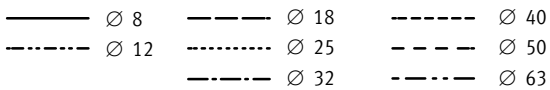
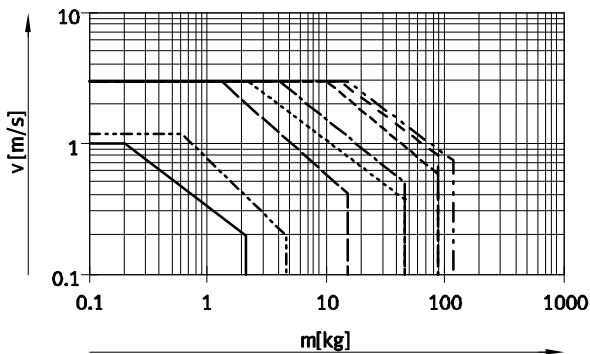

Piston \varnothing 8 ... 40 with YSRW cushioning

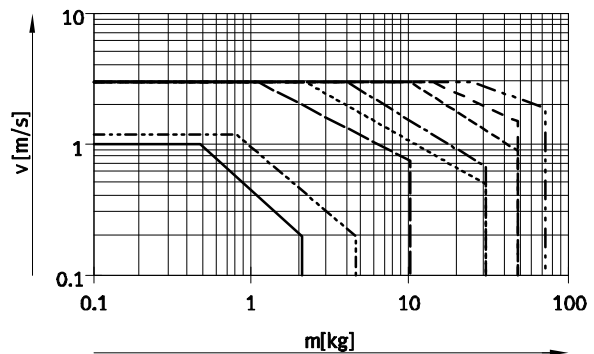

 Note
This data represents the maximum values that can be achieved. Values fluctuate in practice relative to the position of the effective load and mounting position.

Operating range of cushioning

The end-position cushioning must be adjusted to ensure jerk-free operation. If the operating conditions are outside the permissible range, the

load to be moved must be cushioned using suitable equipment (shock absorbers, stops, etc.), preferably at the centre of gravity of the load.

 Note
To avoid distortion in the slide, the bearing surfaces of the attachments must maintain a flatness of 0.01 mm.

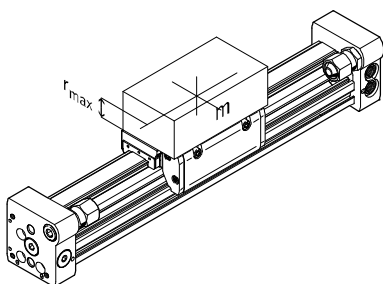

The specifications apply to a horizontal mounting position:

Piston \varnothing	8	12	18	25	32	40	50	63
Distance r_{max} [mm]	25	35	35	50	50	50	50	50

Passive guide axes DGC-FA, without drive

Technical data



Number of profile mountings MUC as a function of force due to weight F and support span l

In order to limit deflection in the case of large strokes, the guide axis may need to be supported. The following

graphs help to determine the maximum permissible support span

as a function of mounting position, force due to weight and normal force.

Horizontal mounting position

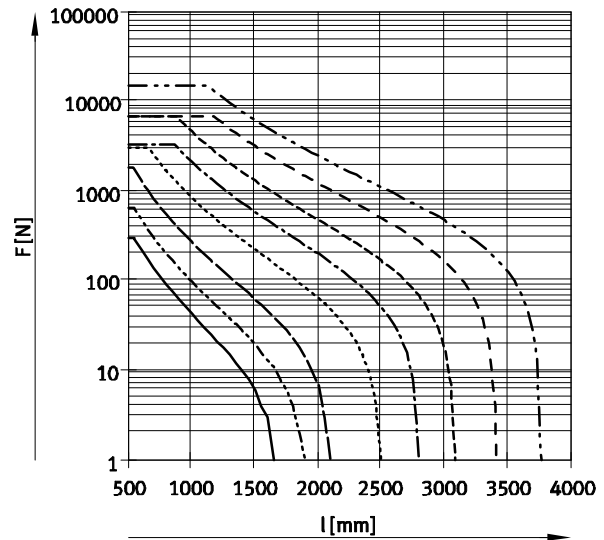
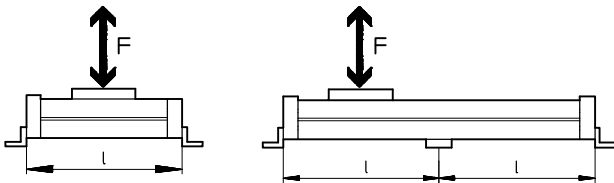

Vertical mounting position

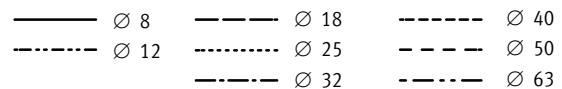
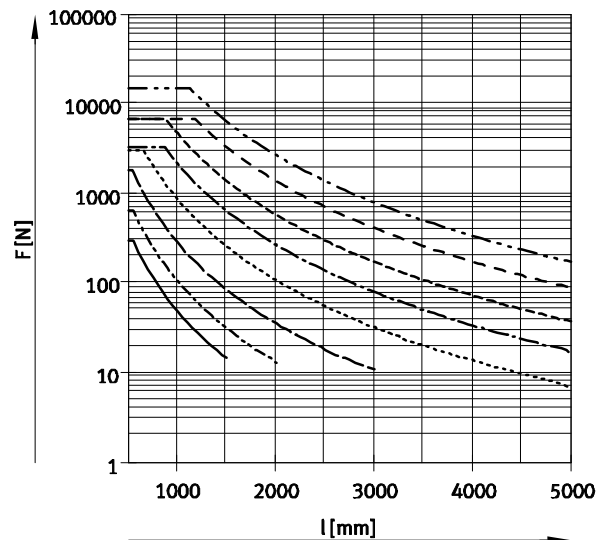
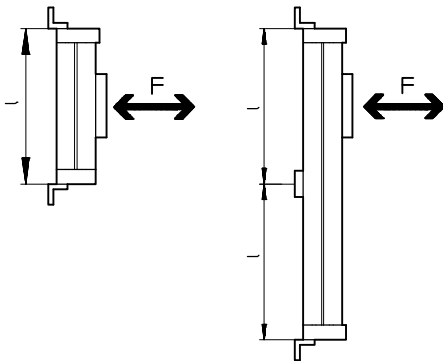

Example:

The guide axis DGC-25-1500 is subjected to a force of 300 N in the horizontal mounting position.

The axis has an overall length of:

$$\begin{aligned} l &= \text{stroke length} + L1 \\ &= 1500 \text{ mm} + 200 \text{ mm} \\ &= 1700 \text{ mm} \end{aligned}$$

According to the graph, the max. support span for the axis DGC-25 with a force of 300 N is 1300 mm.

In this example, profile mountings are required as the max. support span (1300 mm) is smaller than the overall length of the axis (1700 mm).

Passive guide axes DGC-FA, without drive

Technical data

Central lubrication

The lubrication adapter enables the guide of the passive guide axis DGC-FA to be permanently lubricated in applications in humid or wet ambient conditions using semi or fully automatic relubrication devices.

- For piston \varnothing 25, 32, 40, 63
- The modules are suitable for oils and greases
- The dimensions of the passive guide axis DGC-FA are the same with and without central lubrication modules
- Both lubrication adapters must be connected
- There are three connection options on each side
- Can be used in combination with:
 - Additional slide K
- Cannot be used in combination with:
 - Protected recirculating ball bearing guide GP

Slide dimensions
→ 22

Order code C in the modular product system → 27

Connection options

Only the connection at the rear or on the top can be used in combination with shock absorbers in the end caps.

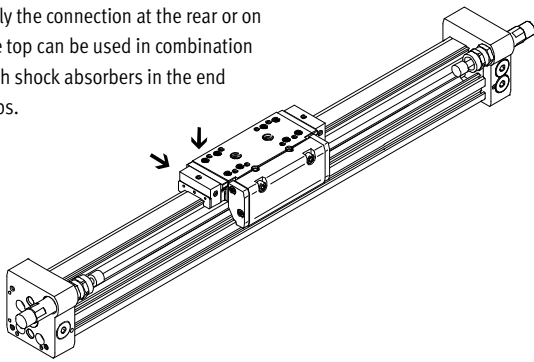

Only the connection on the front or top can be used in combination with shock absorber retainer DADP.

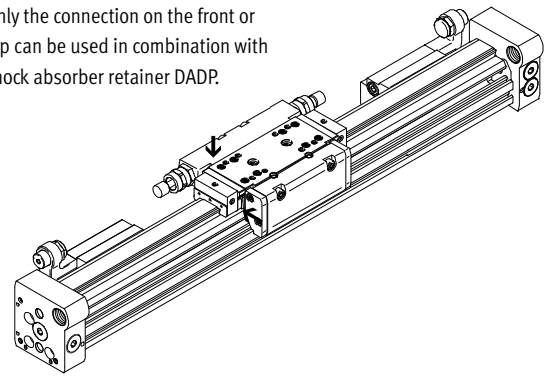

Connection option for customer design

The drawing opposite shows the connection option on the top lubrication interface using a customer design.

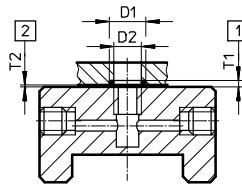

- D1 8^{+0.2} mm
- D2 6 mm
- T1 0.6_{-0.05} mm
- T2 0.1^{+0.2} mm
- O-ring \varnothing 6x1 mm (DIN3771)

- 1 Slot depth for O-ring
- 2 Required air gap

Additional dimensions → 22

Structure of a central lubrication system

A central lubrication system requires various additional components. The illustration shows different options (using a hand pump, pneumatic container pump or electric container pump) required as a minimum for designing a central lubrication system. Festo does not sell these additional components, however they can be obtained from the following companies:

- Lincoln
- Bielomatik
- SKF (Vogel)

Festo recommends these companies because they can supply all the necessary components.

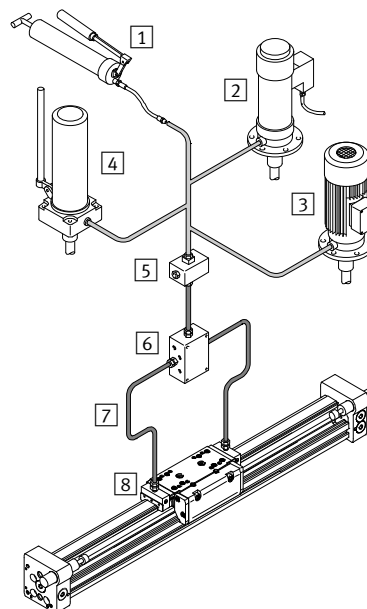

- 1 Hand pump
- 2 Pneumatic container pump
- 3 Electric container pump
- 4 Manually operated container pump
- 5 Nipple block
- 6 Distributor block
- 7 Tubing or piping
- 8 Fittings

Passive guide axes DGC-FA, without drive

Technical data

FESTO

Dimensions

Download CAD data → www.festo.com

∅ 8 and 12

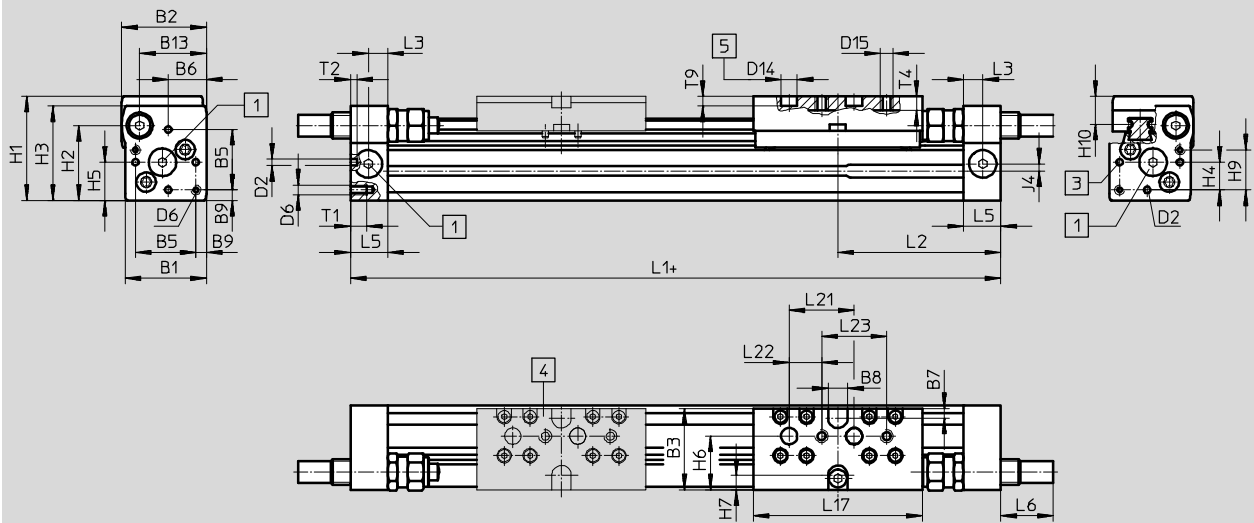

+ = plus stroke length

- 1 The ports on the end caps are sealed with blanking plugs
- 3 Mounting hole for foot mounting or centring pin
- 4 Additional slide K
- 5 Hole for centring pin ZBS

Passive guide axes DGC-FA, without drive

Technical data

∅ [mm]	B1	B2	B3	B5	B6	B7	B8 ±0.05	B9 ±0.1	B13	D2 ∅ H8
8	25	26	25	18.6	11.7	3	6	3.2	20.5	2
12	30.2	31	31	20.6	13.5	3	8	4.8	25	2

∅ [mm]	D6	D14 ∅ H7	D15	H1	H2	H3	H4	H5	H6	H7
8	M3	5	M4	32	23	29	8.5	11.7	16.5	4.5
12	M4	5	M4	37.5	28.5	34.5	8.7	13.5	20.5	5

∅ [mm]	H9	H10	J4	L1	L2	L3	L5	L6		
								P	YSR	YSRW
8	12.3	8.7	2.2	100	50.1	6	11.5	0	16	16.2
12	14.7	9.8	3	125	62.1	8	16	0	11.3	12.3

∅ [mm]	L17	L21 ±0.03	L22 ±0.1	L23 ±0.1	T1	T2	T4	T9 ±0.2	Stroke tolerance
8	52	20	10	20	5	2	4.3	3	0 ... 1.7
12	65	20	10	20	6	2	5	3	

Profile barrel

∅ 8

∅ 12

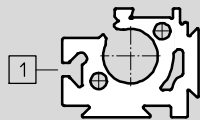
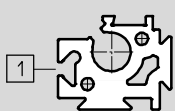

1 Sensor slot for proximity sensor

Passive guide axes DGC-FA, without drive

Technical data

FESTO

Dimensions

Download CAD data → www.festo.com

Ø 18 ... 40

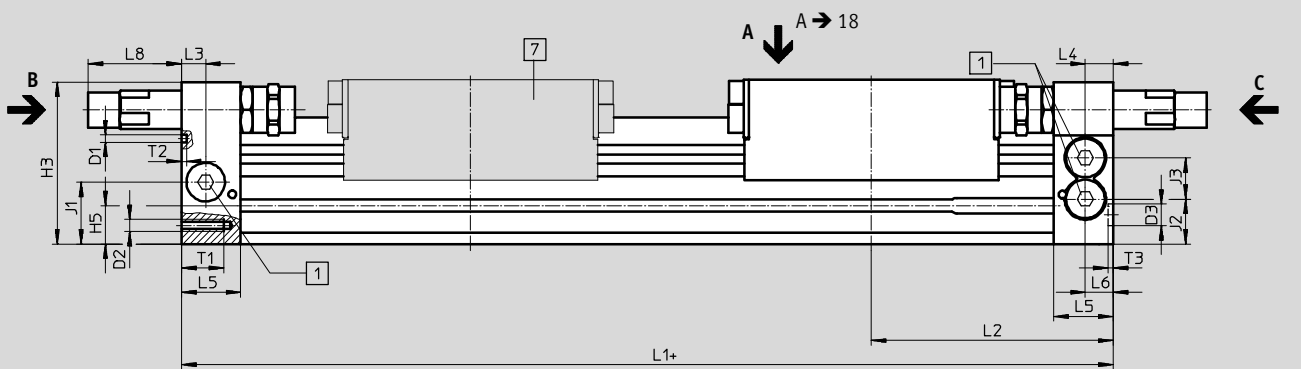

View C

Ø 18 ... 40

View B

Ø 18

Ø 25 ... 40

Ø 18 ... 40

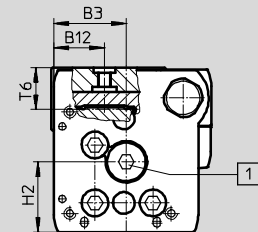
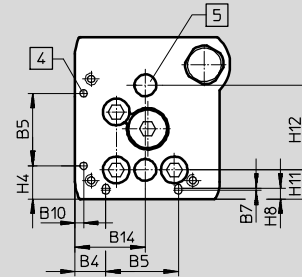
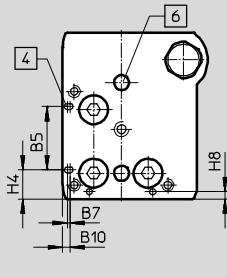
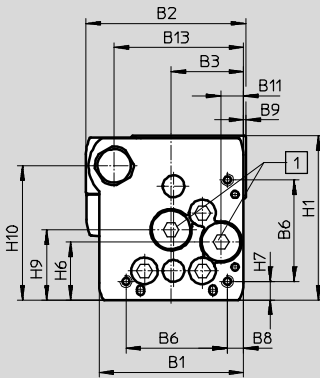

Ø 50/63

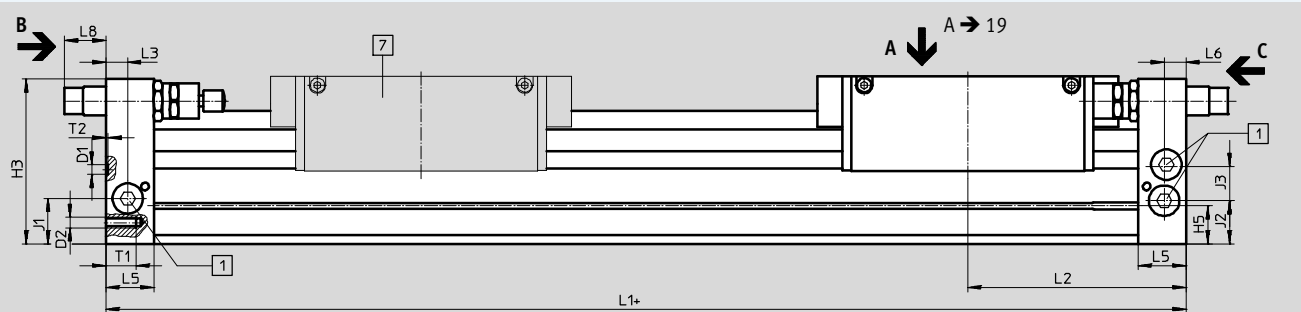

View C

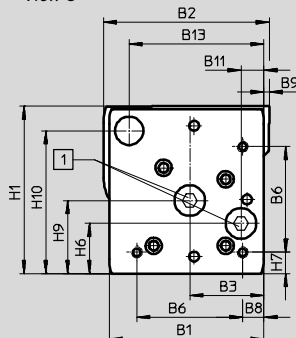

View B

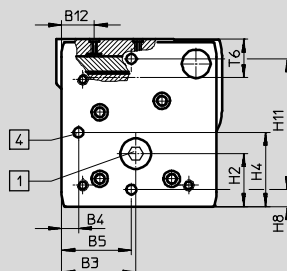

+ = plus stroke length

- 1 The ports on the end caps are sealed with blanking plugs
- 4 Mounting hole for foot mounting HPC
- 5 Hole for centring sleeve ZBH
- 6 Hole for centring pin ZBS
- 7 Additional slide

Passive guide axes DGC-FA, without drive

Technical data

∅ [mm]	B1	B2	B3	B4	B5	B6	B7	B8	B9	B10	B11	B12
18	44.5	49.9	19.5±0.05	8.8±0.1	21±0.05	31	0.8	3.8±0.1	1	2.4	5.5	15.5
25	59.8	66	30±0.05	12.65±0.1	30±0.05	42	1	6.65±0.1	1	3.5	9.3	21
32	73	79	38.5±0.05	5.7±0.1	63.1±0.05	57.5	–	8.5±0.1	1.5	14	14.9	18
40	91	98.5	45±0.05	17.2±0.1	55±0.05	65	–	12.2±0.1	2	8	16.5	24.8
50	113	126.5	60	8±0.2	52.8	81.6	–	12	0	–	21	24
63	142	149	68	15.5±0.2	68	97	–	19.5	5	–	21	30

∅ [mm]	B13	B14	D1 ∅	D2	D3 ∅ H7	H1	H2	H3	H4 ±0.2	H5	H6
18	39	19.5	2±0.05	M4	5	56.3	23.1	55	9.6±0.2	13.4	20
25	53	29	3±0.05	M5	9	68	29	67	13.65±0.2	15.8	24
32	65	38.5	3±0.05	M6	9	78.5	30	77	5.7±0.2	17	27.7
40	80.5	45	4±0.05	M6	9	99.5	41.5	97.5	17.2±0.2	25	36.5
50	97	–	9 ^{H7}	M8	–	124.5	38.5	122.5	52.8	29.3	36
63	123.5	–	9 ^{H7}	M10	–	153.5	48.5	151	68	34.8	46

∅ [mm]	H7	H8	H9	H10	H11 ±0.15	H12 ±0.05	J1	J2	J3	L1	
										KF	KF-GP
18	4.6	2.4	25.2	46	8.5±0.15	30	20	16.5	11	150	157
25	7.65	4.5	29	55.5	12±0.15	35	26.1	18.6	17	200	205
32	8.5	14	35.2	63.8	11.45±0.15	50	30	22	18.5	250	250
40	12.2	8	44	81.5	15±0.15	60	35	26	26	300	312
50	12	8	53	104.5	100±0.05	–	30.5	30.5	28	350	–
63	19.5	15.5	67	131	120±0.05	–	41.5	39.5	31.5	400	–

∅ [mm]	L2		L3	L4	L5	L6	L8		T1	T2	T3 +0.2	T6	Stroke tolerance
	KF	KF-GP					YSR	YSRW					
18	74.5	78	5.7	5.8	15	5.5	29.9	32.4	9	2	3.1	15	0 ... 2.5
25	100	102.5	10.5	10.6	24.5	10.6	35.6	38.6	17.5	2	2.1	17.3	
32	124.8	124.8	14.5	14.5	30.5	14.5	19.5	28	15	2	2.1	20	
40	150	156	14.6	14.6	33.5	14.6	38.5	43.5	20	3	2.1	25.7	
50	175	–	17	–	41	17	31	36.3	24	2.1 ^{+0.2}	–	28.75	
63	200	–	20	–	44	20	38.3	48.3	27.5	2.1 ^{+0.2}	–	36.1	

Passive guide axes DGC-FA, without drive

Technical data

FESTO

Dimensions

Download CAD data → www.festo.com

Slide

Ø 18

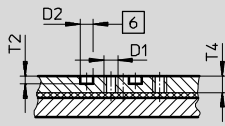

View A

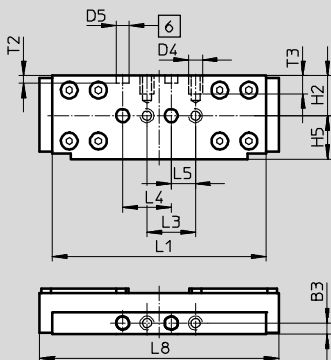

Ø 25

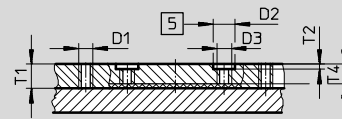

View A

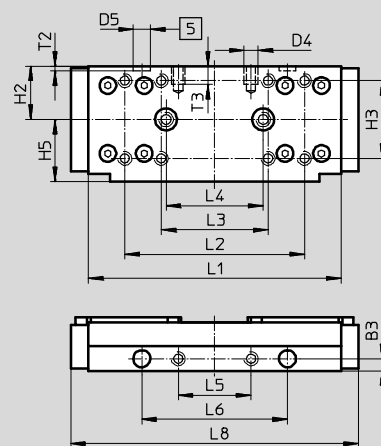

Ø 32

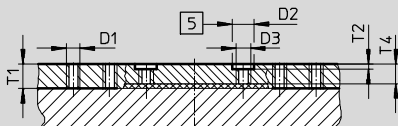

View A

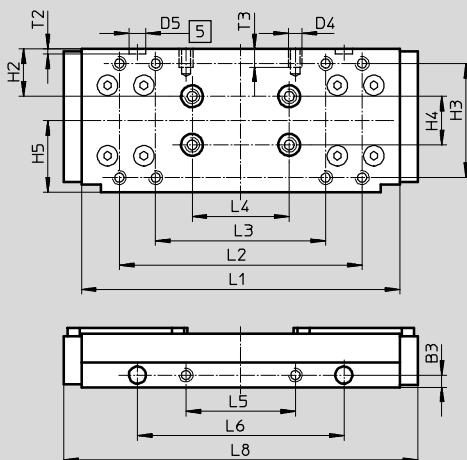

Ø 40

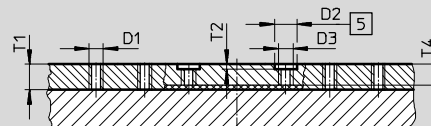

View A

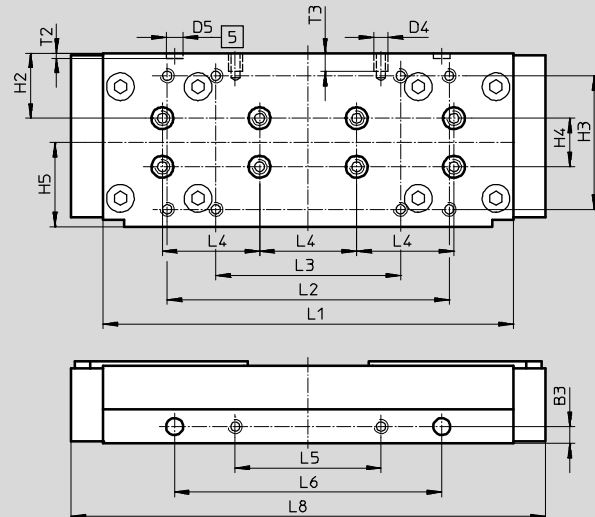

5 Hole for centring sleeve ZBH

6 Hole for centring pin ZBS

Passive guide axes DGC-FA, without drive

Technical data

Dimensions

Download CAD data → www.festo.com

Slide

Ø 50

Ø 63

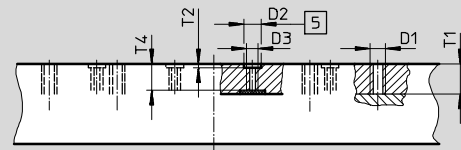
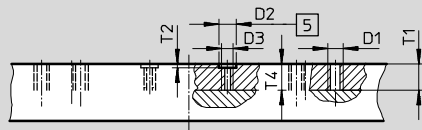

View A

View A

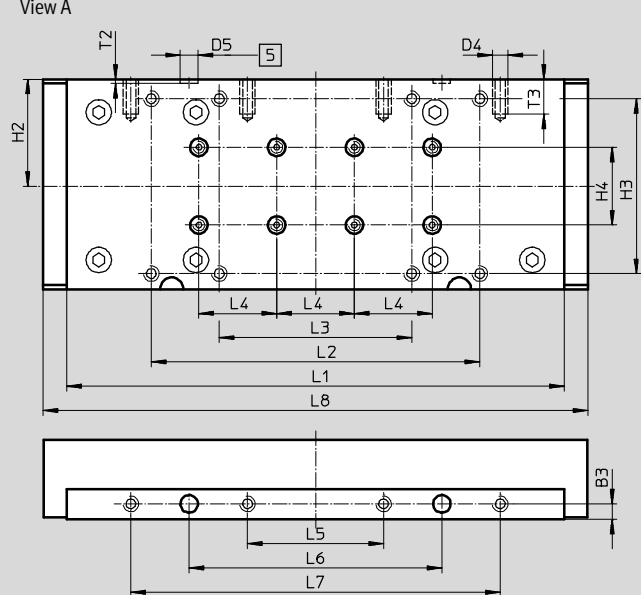
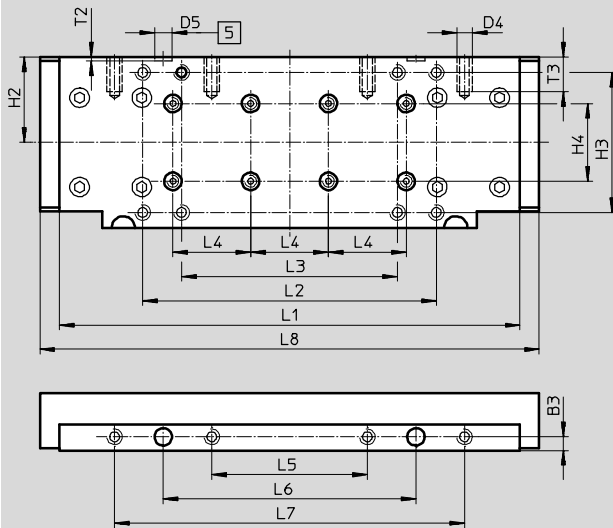

- 5 Hole for centring sleeve ZBH
- 6 Hole for centring pin ZBS

Ø	B3	D1	D2	D3	D4	D5	H2	H3	H4	H5	L1
[mm]	±0.05		Ø H7			Ø H7			±0.03	±0.1	
18	4.5	M5	5	-	M5	5	16.5	-	-	18	88±0.1
25	5	M5	9	M6	M5	7	22	32±0.2	-	25.5	104±0.2
32	5	M5	9	M6	M5	7	19.5	47±0.2	20	29.5	131±0.2
40	7	M5	9	M6	M6	7	26.8	55±0.2	20	34.7	169±0.2
50	7	M8	9	M6	M8	9	44	72±0.3	40	-	237±0.1
63	8	M8	9	M6	M8	9	55	90±0.3	40	-	256±0.1

Ø	L2	L3	L4	L5	L6	L7	L8	T1	T2	T3	T4
[mm]	±0.2		±0.03	±0.1	±0.05	±0.1					
18	-	20±0.1	20	10	-	-	99	-	3.1±0.1	7.5	6.7
25	74	44±0.2	40	30	60	-	118.5	10	2.1±0.2	7.5	8
32	100	70±0.2	40	45	85	-	145.7	10	2.1±0.2	7.5	8
40	116	76±0.2	40	60	110	-	195.4	10.5	2.1±0.2	7.5	8.5
50	151	111±0.2	40	80	130	180	256.8	13.5	2.1±0.2	18	13.5
63	169	99±0.2	40	70	130	190	280	15.5	2.1±0.2	18	13.6

Passive guide axes DGC-FA, without drive

Technical data

FESTO

Dimensions

Download CAD data → www.festo.com

Slide, variant GP – Protected recirculating ball bearing guide

Ø 18

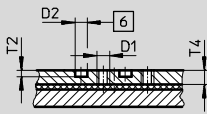

View A

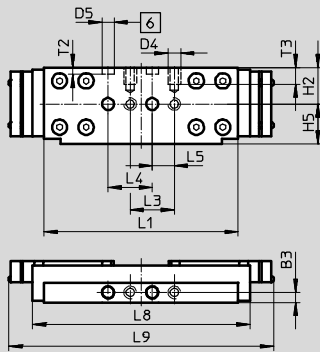

Ø 25

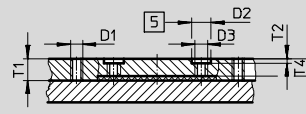

View A

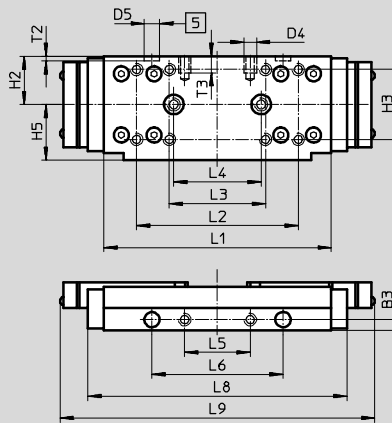

Ø 32

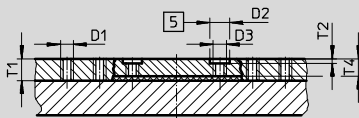

View A

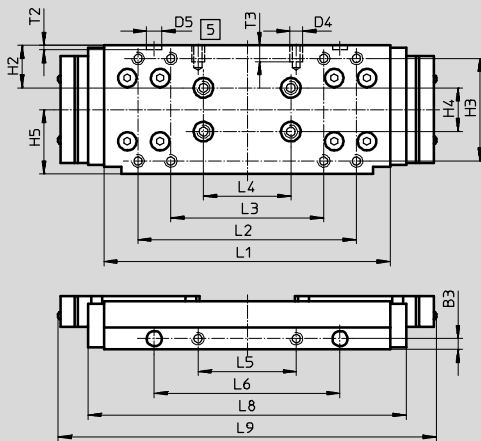

Ø 40

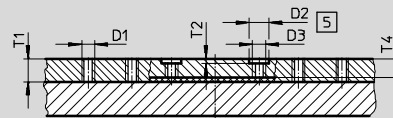

View A

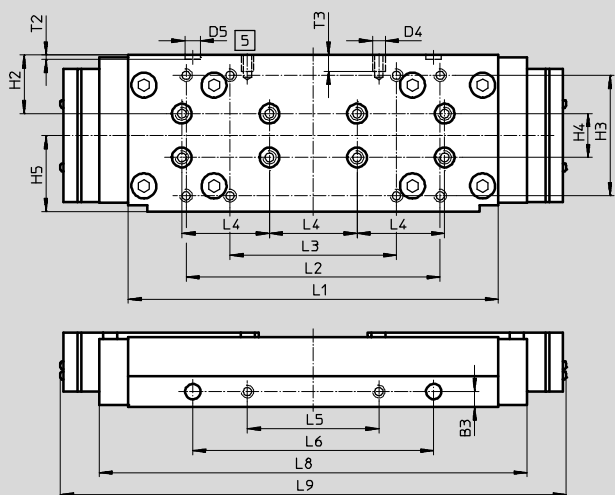

5 Hole for centring sleeve ZBH

6 Hole for centring pin ZBS

Passive guide axes DGC-FA, without drive

FESTO

Technical data

∅ [mm]	B3 ±0.05	D1	D2 ∅ H7	D3	D4	D5 ∅ H7	H2	H3
18	4.5	M5	5	–	M5	5	16.5	–
25	5	M5	9	M6	M5	7	22	32±0.2
32	5	M5	9	M6	M5	7	19.5	47±0.2
40	7	M5	9	M6	M6	7	26.8	55±0.2
50	7	M8	9	M6	M8	9	44	72±0.3
63	8	M8	9	M6	M8	9	55	90±0.3

∅ [mm]	H4 ±0.03	H5 ±0.1	L1	L2 ±0.2	L3	L4 ±0.03	L5 ±0.1	L6 ±0.05
18	–	18	88±0.1	–	20±0.1	20	10	–
25	–	25.5	104±0.2	74	44±0.2	40	30	60
32	20	29.5	131±0.2	100	70±0.2	40	45	85
40	20	34.7	169±0.2	116	76±0.2	40	60	110
50	40	–	237±0.1	151	111±0.2	40	80	130
63	40	–	256±0.1	169	99±0.2	40	70	130

∅ [mm]	L7 ±0.1	L8	L9	T1	T2	T3	T4
18	–	99	120	–	3.1±0.1	7.5	6.7
25	–	118.5	144	10	2.1±0.2	7.5	8
32	–	145.7	173	10	2.1±0.2	7.5	8
40	–	195.4	231	10.5	2.1±0.2	7.5	8.5
50	180	256.8	–	13.5	2.1±0.2	18	13.5
63	190	280	–	15.5	2.1±0.2	18	13.6

Passive guide axes DGC-FA, without drive

Technical data

FESTO

Dimensions

Download CAD data → www.festo.com

Slide, variant C – Lubrication adapter

Ø 25

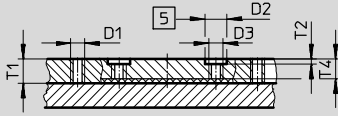

View A

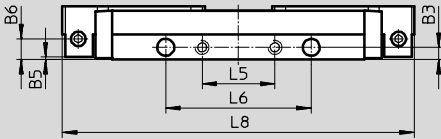
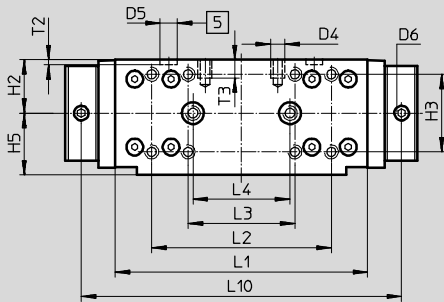

Ø 32

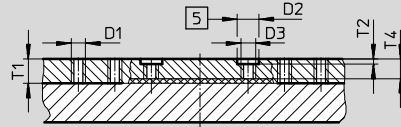

View A

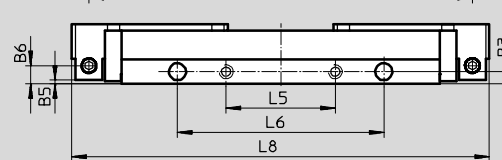
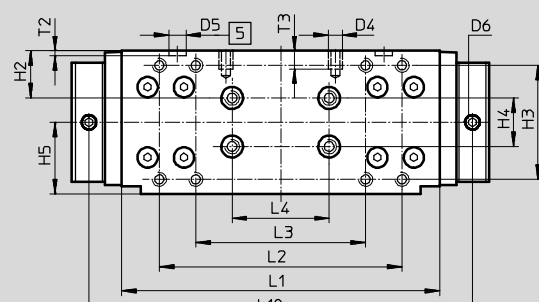

Ø 40

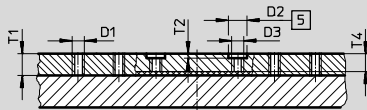

View A

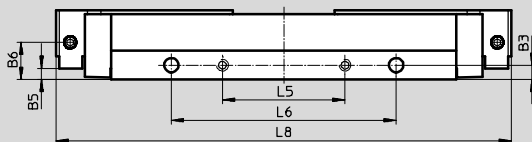
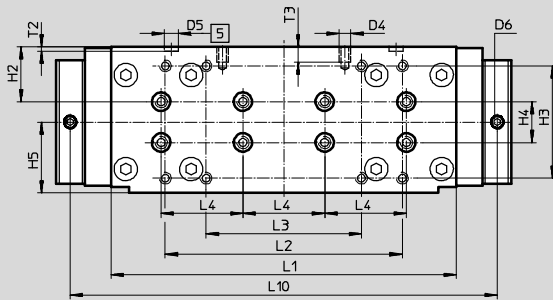

Ø 63

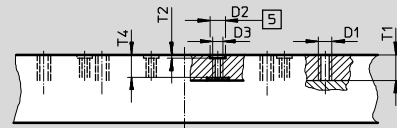

View A

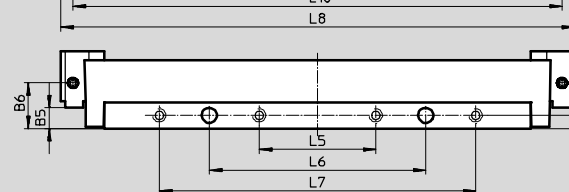
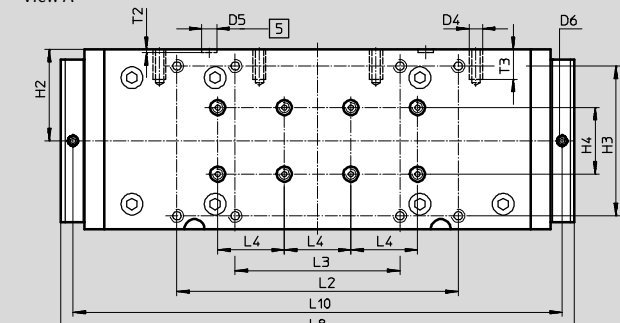

5 Hole for centring sleeve ZBH

Passive guide axes DGC-FA, without drive

Technical data

∅	B3	B5	B6	D1	D2	D3	D4	D5	D6	H2	H3	H4	H5
[mm]	±0.05	±0.05			∅ H7			∅ H7				±0.03	±0.1
25	5	1	8.5	M5	9	M6	M5	7	M6x1	22	32±0.2	-	25.5
32	5	1.5	7.5	M5	9	M6	M5	7	M6x1	19.5	47±0.2	20	29.5
40	7	18.2	18.2	M5	9	M6	M6	7	M6x1	26.8	55±0.2	20	34.7
63	8	12.5	27.5	M8	9	M6	M8	9	M6x1	55	90±0.3	40	-

∅	L1	L2	L3	L4	L5	L6	L7	L8	L10	T1	T2	T3	T4
[mm]		±0.2	±0.2	±0.03	±0.1	±0.05	±0.1				±0.2		
25	104±0.2	74	44	40	30	60	-	145	132	10	2.1	7.5	8
32	131±0.2	100	70	40	45	85	-	172	158	10	2.1	7.5	8
40	169±0.2	116	76	40	60	110	-	223	209	10.5	2.1	7.5	8.5
63	256±0.1	169	99	40	70	130	190	308.4	293.8	15.5	2.1	18	13.6

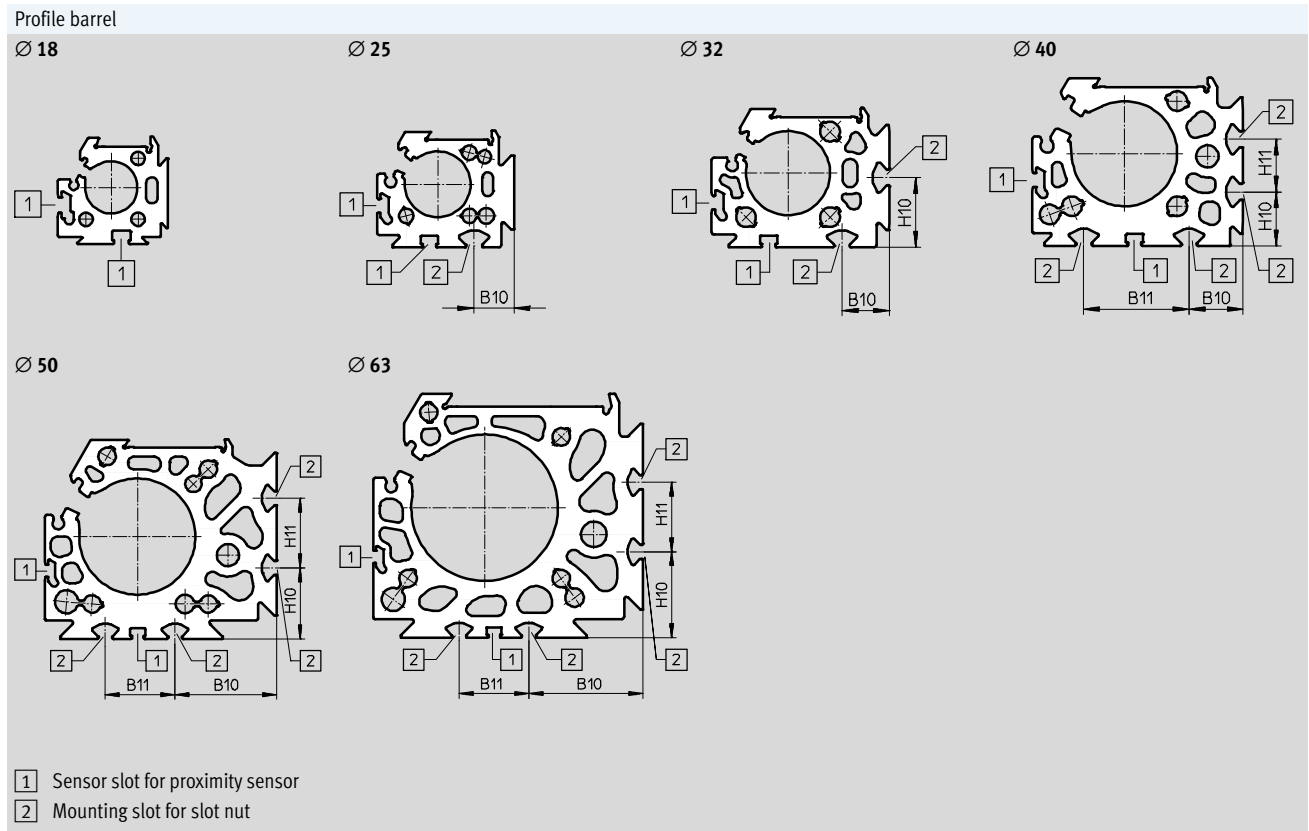

∅	B10	B11	H10	H11
[mm]				
25	15.23	-	-	-
32	18	-	26.5	-
40	20.5	40	20.5	20
50	43.8	30	30.5	30
63	49	30	37	30

Passive guide axes DGC-FA, without drive

Technical data

FESTO

Dimensions

Download CAD data → www.festo.com

1H – With clamping unit

Size 25/32

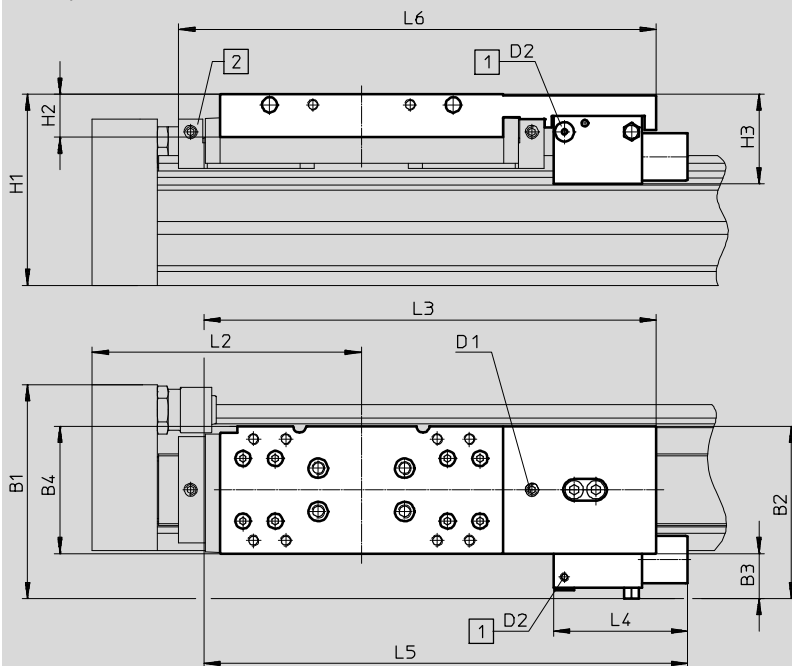

- Note

Total length L1 with stroke = 0 mm

→ 16

1 Supply port

2 Lubrication adapter

Type	B1	B2	B3	B4	H1	H2	H3	D1	D2	L2	L3	L4	L5	L6
DGC-25-...-1H-PN	83.6	64.9	17.6	47.5	79	21	39.5	M6	M5	100	182.3	63	198	-
DGC-25-...-C-1H-PN														193.8
DGC-32-...-1H-PN	99.9	79.9	20.9	59	88.5	20	41.5	M6	M5	124.8	209.4	62	223.9	-
DGC-32-...-C-1H-PN														221

Passive guide axes DGC-FA, without drive

Technical data

Dimensions

Download CAD data → www.festo.com

1H – With clamping unit

Size 40/50

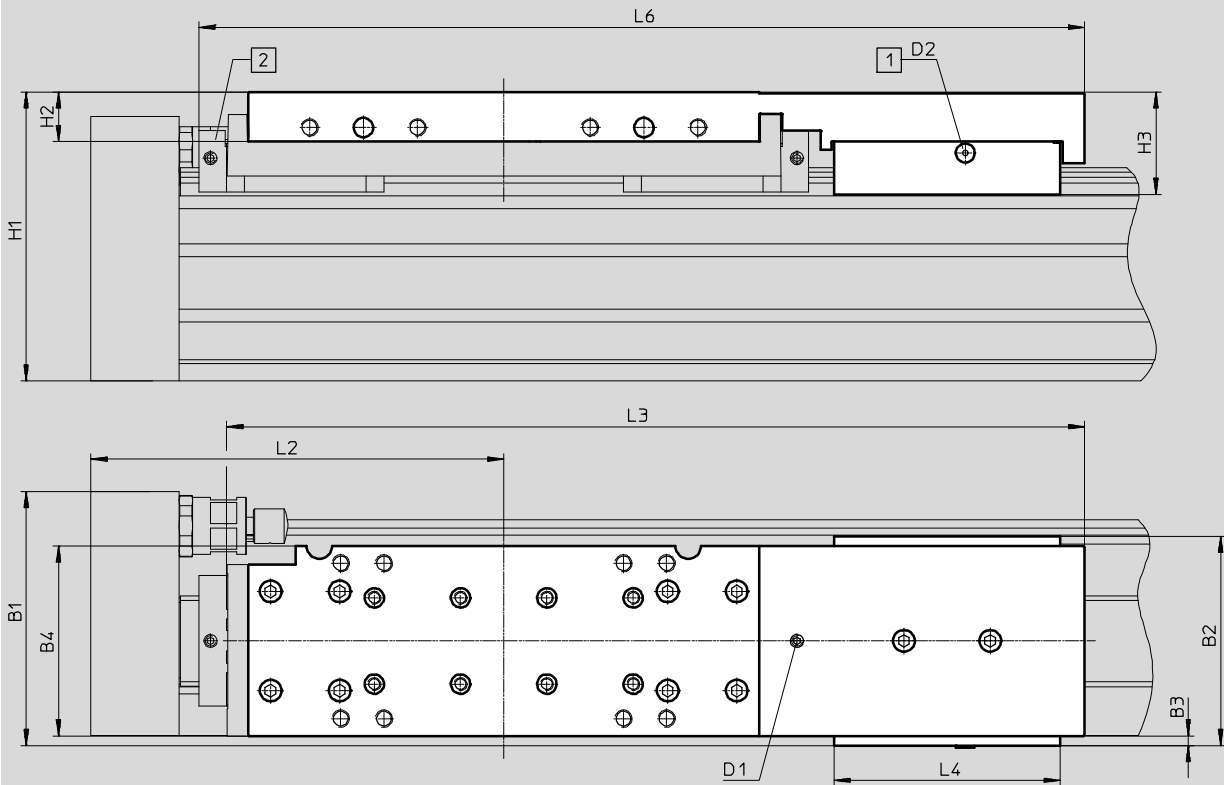

- Note

Total length L1 with stroke = 0 mm

→ 16

1 Supply port

2 Lubrication adapter

Type	B1	B2	B3	B4	H1	H2	H3	D1	D2	L2	L3	L4	L6
DGC-40-...-1H-PN	109.9	97	11.7	69.4	113.5	28	48.9	M6	M5	150	331.2	105	-
DGC-40-...-C-1H-PN													345.7
DGC-50-...-1H-PN	117.8	97	4.5	88	134	23	47.4	M6	M5	175	397.6	105	-
DGC-50-...-C-1H-PN													412.1

Passive guide axes DGC-FA, without drive

Ordering data – Modular products

Order code

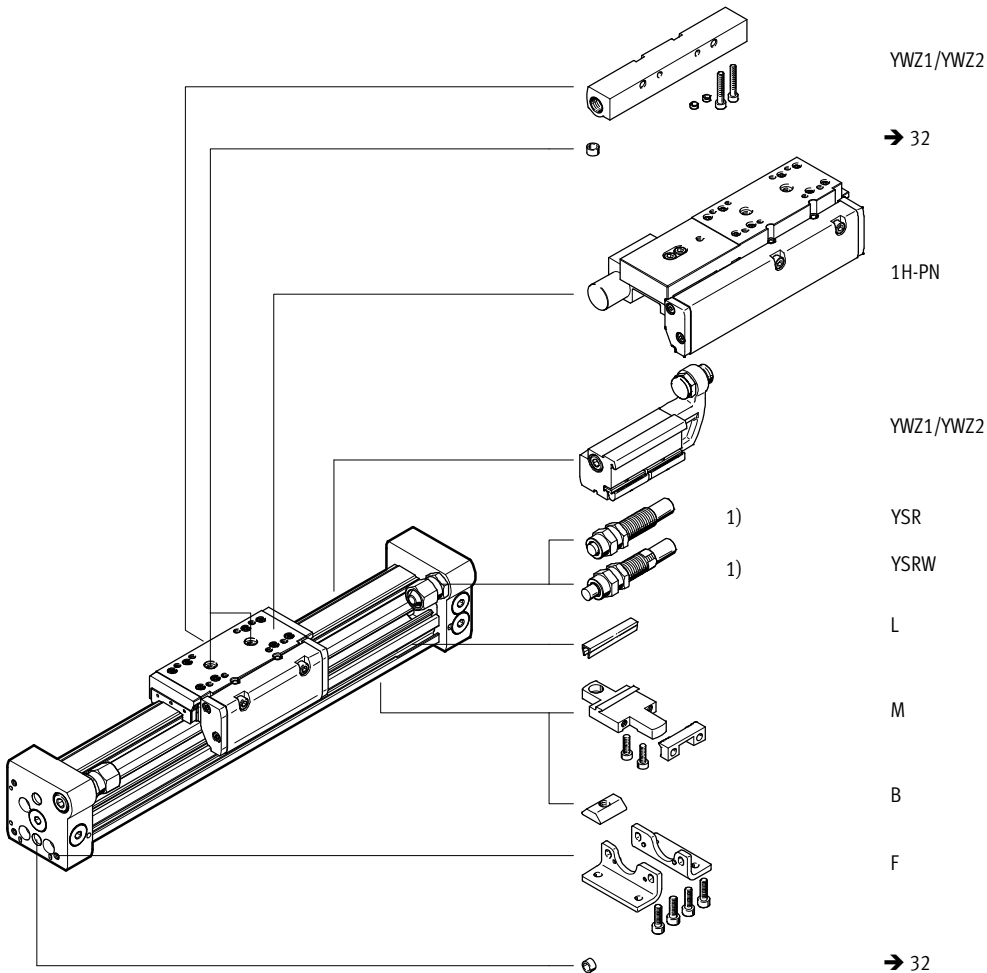

Effective stroke reduction when ordering an additional slide K

For a linear drive DGC with additional slide, the effective stroke is reduced by the length of the additional slide and the distance between both slides.

Given:
 DGC-12-500-...
 L = 20 mm
 L17 = 65 mm

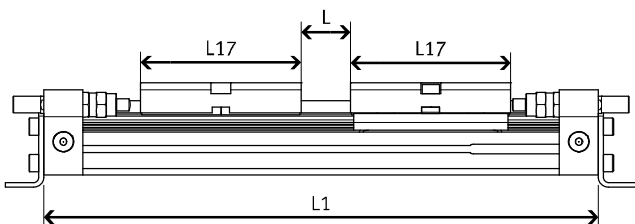

∅ [mm]	8	12	18	25	32	40	50	63
L17	52	65	99	118.5	145.7	195.4	256.8	280

The effective stroke is reduced to
 415 mm = 500 mm – 20 mm – 65 mm

Passive guide axes DGC-FA, without drive

Ordering data – Modular products

Ordering table												
Size	8	12	18	25	32	40	50	63	Condi- tions	Code	Enter code	
M Module No.	530906	530907	532446	532447	532448	532449	532450	532451				
Function	Linear drive									DGC	DGC	
Piston Ø [mm]	8	12	18	25	32	40	50	63		-...		
Stroke [mm]	1 ... 1300	1 ... 1900	1 ... 3000	1 ... 5000					[1]	-...		
Guide	Passive guide axis									-FA	-FA	
Cushioning	Elastic cushioning rings/pads at both ends									-P		
	Shock absorber, self-adjusting									-YSR		
	Shock absorber, self-adjusting, progressive									-YSRW		
O Slide	-	-	Protected recirculating ball bearing guide			-	-		[2]	-GP		
Lubrication	-		Standard									
	-		Lubrication approved for use in food applications						[3]	-H1		
Lubrication function	Standard											
	-	-	-	Lubrication adapter			-	Lubrica- tion adapter	[4]	-C		
Additional slide	1 ... 2								[5]	-...K		
Clamping unit	-		-		None			-				
	-		-		1-channel			-	[6]	-1H		
Actuation type	-		-		None			-				
	-		-		Pneumatic			-	[6]	-PN		
EU certification	II 3GD								[7]	-EX2		
	II 2G								[7]	-EX3		
Accessories	Enclosed separately (can be retrofitted)										ZUB-	ZUB-
Foot mounting	1										F	
Profile mounting	1 ... 9										...M	
Slot nut for mounting slot	-	-	-	1 ... 9						...B		
Slot cover for sensor slot	-	-	1 ... 9								...L	
Mechanical end-position limiter	-		Variable end position, at one end							YWZ1		
	-		Variable end position, at both ends						[8]	YWZ2		
Manual	Express waiver – no operating instructions to be included (already available)									[8]	-O	

- [1] **Stroke** Size 25, 32, 40: strokes up to 8,500 mm on request
- [2] **GP** Not with cushioning YSR and YSRW
Not with additional slide K
- [3] **H1** Not with protected version GP, cushioning YSR, YSRW or clamping unit 1H
- [4] **C** Not with slide GP
- [5] **K** For a linear drive DGC with additional slide, the effective stroke is reduced by the length of the additional slide and the distance between both slides
Not with cushioning P
- [6] **1H, PN** Not with intermediate position Z1, Z2, Z3; end-position limiter YWZ1, YWZ2; protected version GP; additional slide KL, KR or lubrication H1
Only with cushioning YSRW
1H only with PN
- [7] **EX2, EX3** Not with protected version GP, lubrication adapter C, additional slide K, clamping unit 1H-PN
- [8] **YWZ1, YWZ2** Only with cushioning YSR or YSRW

- M** Mandatory data
- O** Options

Transfer order code

Passive guide axes DGC-FA, without drive

Accessories



Foot mounting HPC
(order code: F)

Material:
Galvanised steel

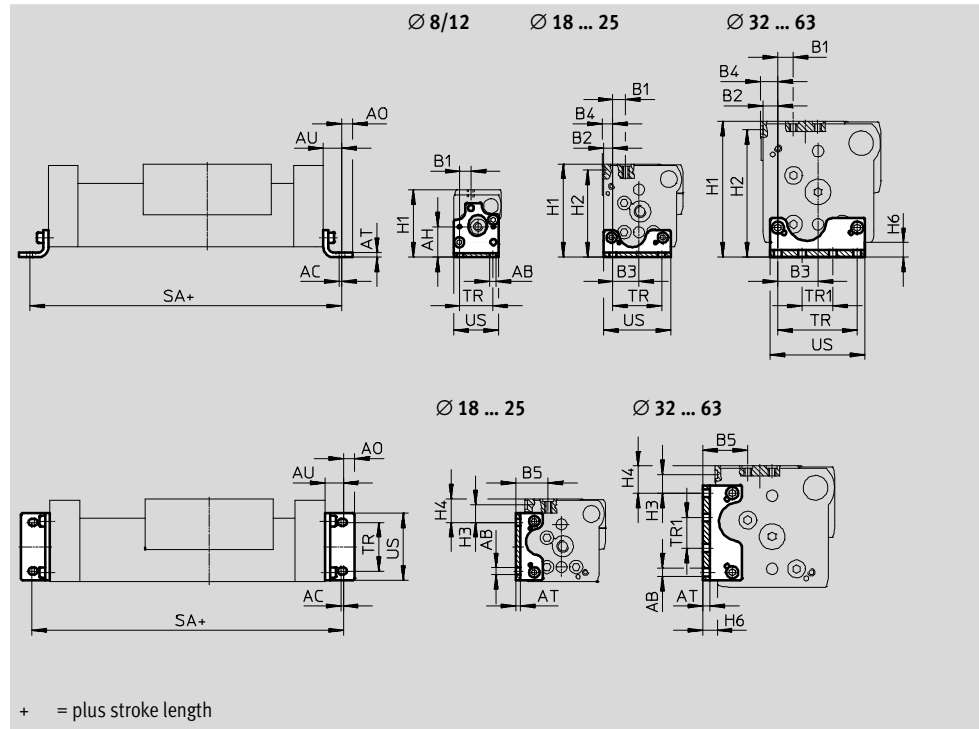

Dimensions and ordering data

For Ø	AB Ø	AC	AH	AO	AT	AU	B1	B2	B3	B4	B5	H1
[mm]												
8	3.4	1.5	16.7	3	2	9	6	-	-	-	-	37
12	4.5	2	18.5	4.5	2	11.5	5.4	-	-	-	-	42.5
18	5.5	2	-	6.75	3	13.25	11.2	4.3	15.2	5.3	23.2	64
25	5.5	2	-	9	4	15	13.35	7.65	21.35	8.65	29.5	76.5
32	6.6	2	-	10	5	19	11.5	9	29.5	10.5	27	87.5
40	6.6	2	-	10	6	20	12.6	12.2	32.8	14.2	36.8	111.5
50	9	3	-	11	8	25	12.5	11.5	48.5	11.5	41	141.5
63	11	3	-	13.5	8	28	17.5	12.5	55.5	17.5	49	172.5

For Ø	H2	H3	H4	H6	SA	TR	TR1	US	Weight	Part No.	Type ¹⁾
[mm]					-0.2	±0.1	±0.1		[g]		
8	-	-	-	5	118	18	-	24.4	26	526385	HPC-8
12	-	-	-	5	148	20	-	29.6	38	526388	HPC-12
18	59.5	16.7	21.5	7.7	176	30	-	38.6	58	533667	HPC-18
25	71.5	14.35	19.35	8.5	230	40	-	55	131	533668	HPC-25
32	82.5	8	13	9	288	56.5	19.5	68	239	533669	HPC-32
40	104.5	15.3	22.3	12	340	65	25	78	348	533670	HPC-40
50	134.5	23.4	30.4	17	400	82.6	47.4	102	754	545236	HPC-50
63	164.5	22	30	19	456	111	39	133	1245	545237	HPC-63

1) Suitable for ATEX areas

Passive guide axes DGC-FA, without drive

Accessories

Profile mounting MUC
(order code: M)

Material:
High-alloy steel

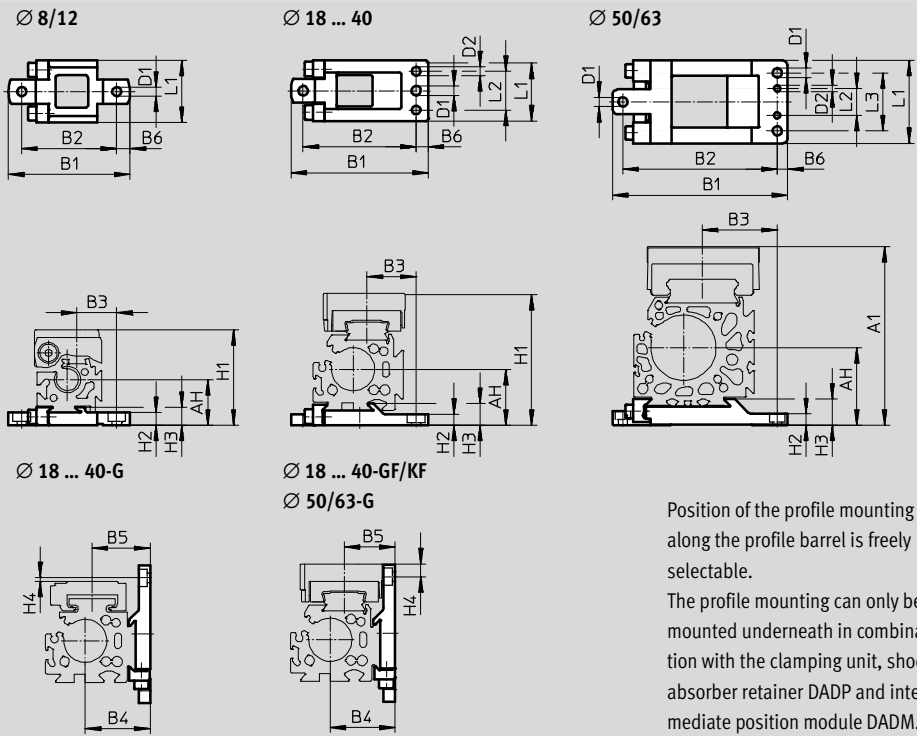

Position of the profile mounting along the profile barrel is freely selectable.
The profile mounting can only be mounted underneath in combination with the clamping unit, shock absorber retainer DADP and intermediate position module DADM.

Dimensions and ordering data									
For \varnothing	AH	B1	B2	B3	B4	B5	B6	D1	D2
[mm]			± 0.2					\varnothing	\varnothing
8	17.7	47	36.7	15.35	-	-	5.1	3.5	-
12	18.5	52.5	42.2	16.5	-	-	5.1	3.5	-
18	27.2	67.8	56	28.7	27.2	28.7	5.7	5.5	5
25	32.5	79.5	65.5	28.5	37.5	29.5	7	5.5	5
32	37.5	94	80	35	47.5	37	7	5.5	5
40	47	110.5	96	43	57	46.8	7	6.5	6
50	61	145	125	56	77	61	7	9	6
63	75	169	149	72.5	87	69	10	9	6

For \varnothing	H1	H2	H3	H4	L1	L2	L3	Weight	Part No.	Type ¹⁾
[mm]								[g]		
8	37	5	7	-	24	-	-	28	526384	MUC-8
12	42.5	4.5	7	-	24	-	-	32	526387	MUC-12
18	64	5.7	9.9	6.4	33	20.5	-	78	531752	MUC-18
25	76.5	6.5	12.5	7.43	35	22.5	-	113	531753	MUC-25
32	87.5	6.5	13	4	45	30	-	174	531754	MUC-32
40	111.5	8.5	16	11.3	60	44	-	346	531755	MUC-40
50	159	11	23.5	9.2	80	26	56	874	531756	MUC-50
63	172.5	11	23.5	15	80	26	56	1080	531757	MUC-63

1) Suitable for ATEX areas

Passive guide axes DGC-FA, without drive

Accessories



Shock absorber retainer DADP
Stop KYC
 (order code: YWZ1 or YWZ2)

Materials: Stop
 Housing: Anodised aluminium
 Stop bracket: Stainless steel casting
 Bracket: High-alloy steel
 Free of copper and PTFE

Materials: Shock absorber retainer
 Housing: Anodised aluminium
 Free of copper and PTFE

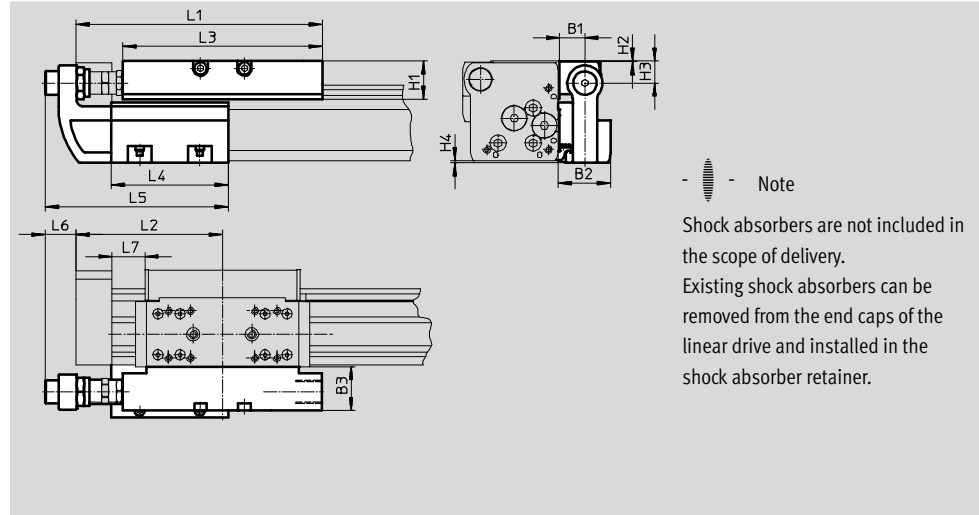

Dimensions							
For \varnothing	B1	B2	B3	H1	H2	H3	H4
[mm]							
18	16	34.5	29	20.7	0.2	12.5	0.7
25	16.5	35	30	25.5	0.5	15	1.4
32	16.5	35	30	25.5	0.5	15	1.7
40	16	35.7	35	37	0.5	21.5	2
50	25	50	41	40.5	0.5	24	0
63	25	50	40	51.5	1.5	33	0

For \varnothing	L1	L2	L3	L4	L5	L6	L7
[mm]							min.
18	128	74.5	107	80	118.5	23.5	14.5
25	168	100	136	80	125	20.5	22.5
32	206.8	124.8	164	120	165	14.5	27.3
40	255	150	210	156	220.5	31	31
50	301	175	252	170	238	27	31
63	328	200	256	200	268	24	41

Passive guide axes DGC-FA, without drive

Accessories

FESTO

Technical data and ordering data

Precision adjustment

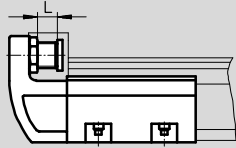

-  - Note

The stop KYC can be used in both directions.

Installation example

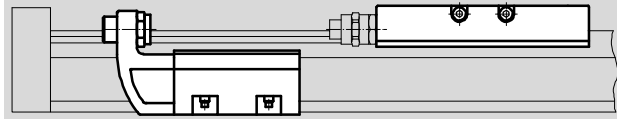

-  - Note

The end stop can be mounted at any position within the stroke.

For Ø [mm]	Precision adjustment L [mm]	Ambient temperature [°C]	CRC ¹⁾	Weight [g]	Part No.	Type ²⁾
Shock absorber retainer						
18	10	-10 ... +80	2	130	541729	DADP-DGC-18-KF
25	10			180	541730	DADP-DGC-25-KF
32	10			215	541731	DADP-DGC-32-KF
40	15			460	541732	DADP-DGC-40-KF
50	15			890	545244	DADP-DGC-50
63	15			1080	545245	DADP-DGC-63
Stop						
18	10	-10 ... +80	2	400	541691	KYC-18
25	10			560	541692	KYC-25
32	10			790	541693	KYC-32
40	15			1525	541694	KYC-40
50	15			2270	545242	KYC-50
63	15			2950	545243	KYC-63

1) Corrosion resistance class CRC 2 to Festo standard FN 940070



Moderate corrosion stress. Indoor applications in which condensation may occur. External visible parts with primarily decorative requirements for the surface and which are in direct contact with the ambient atmosphere typical for industrial applications.

2) Suitable for ATEX areas

Passive guide axes DGC-FA, without drive

FESTO

Accessories

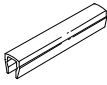
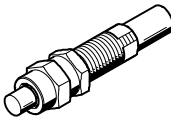
Ordering data						
	For Ø	Remarks	Order code	Part No.	Type	PU ¹⁾
Slot nut NST ²⁾ Technical data → Internet: hmbn						
	25 ... 40	For mounting slot	B	547264	HMBN-5-1M5	10
	50, 63			186566	HMBN-5-2M5	
Centring pin/sleeve ZBS/ZBH ²⁾ Technical data → Internet: zbs, zbh						
	8 ... 18	For slide	-	150928	ZBS-5	10
	25 ... 63			150927	ZBH-9	
	8, 12	For end cap	-	525273	ZBS-2	
	18			150928	ZBS-5	
	25 ... 63			150927	ZBH-9	
Slot cover ABP-S ²⁾ Technical data → Internet: abp						
	18 ... 63	For sensor slot every 0.5 m	L	151680	ABP-5-S	2
Shock absorber ²⁾ Technical data → Internet: ysrw						
	18	For DGC-FA with recirculating ball bearing guide	YSRW	540347	YSRW-DGC-18-KF	1
	25			540349	YSRW-DGC-25-KF	
	32			540351	YSRW-DGC-32-KF	
	40, 50			1232870	YSRW-DGC-40/50-B	
	63			543069	YSRW-DGC-63-GF/KF	

1) Packaging unit

2) Suitable for ATEX areas