

Guided drives DFME-LAS, electric

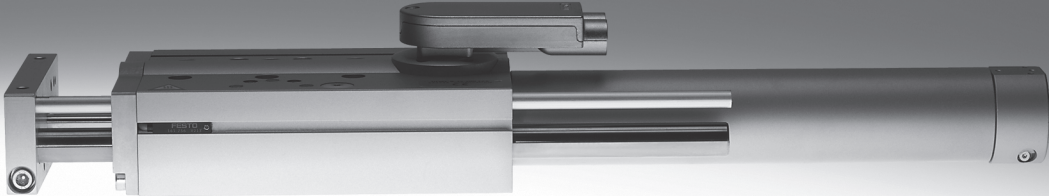

Guided drives DFME-LAS, electric

Key features



At a glance		
Characteristics		Range of applications
<ul style="list-style-type: none"> The guided drive consists of a freely positionable linear motor, integrated displacement encoder with magnetic strip and reference switch Enables positioning with very high dynamic response. Accelerations of up to 80 m/s² are possible without load Mechanical interfaces are largely compatible with the guided drive DFM-B 	<ul style="list-style-type: none"> Together with the motor controller SFC-LACI and the associated cables, it is a quickly commissioned positioning system for small loads 	<ul style="list-style-type: none"> Positioning of small loads such as: <ul style="list-style-type: none"> – placing small parts into and removing small parts from magazines, – sorting parts quickly, – for equipping and assembly processes

Everything from a single source

Guided drive
DFME-LAS
→ 3

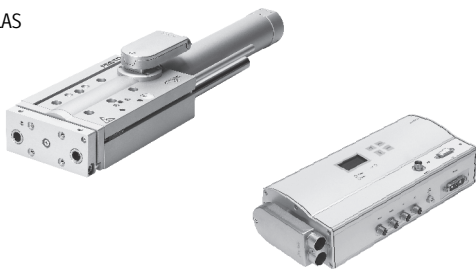

Motor controller
SFC-LACI
→ Internet: sfc-laci

The guided drive DFME-LAS and motor controller SFC-LACI form one unit.

- Thanks to protection class IP54, the SFC can be mounted close to the DFME, either:
 - via central supports or
 - via H-rail
 - Just two cables are required between the guided drive DFME and motor controller SFC (motor and encoder cable)
 - The motor controller SFC is available with or without control panel
 - Up to 31 positioning records
- Parameterisation via:
- Control panel:
 - suitable for simple position sequences

Parameterisation via:

- FCT (Festo Configuration Tool) configuration package:
 - via RS 232 interface
 - Windows-based PC user interface, Festo Configuration Tool
- Easy actuation via:
 - I/O interface
 - Profibus
 - CANopen, incl. “interpolated position mode”
 - DeviceNet



Mounting options

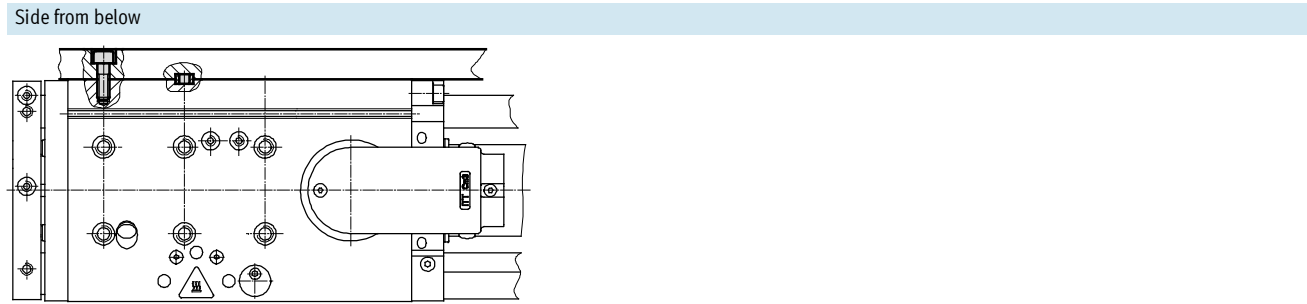
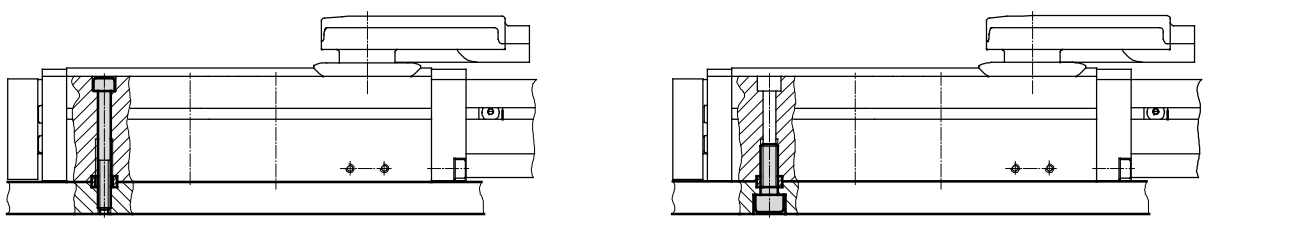

PROFIBUS®, DeviceNet®, CANopen® is a registered trademark of its respective trademark holder in certain countries.

Guided drives DFME-LAS, electric

Type codes

		DFME	-	32	-	100	-	LAS	-	T	-	H	-	KF	-	S1
Type																
DFME	Guided drive															
Size																
Stroke [mm]																
Drive type/motor technology																
LAS	Linear motor, AC synchronous															
Cable outlet																
T	At the top															
S	At the side															
Cable outlet direction																
H	To the rear															
F	To the front															
L	To the left															
R	To the right															
Guide																
KF	Recirculating ball bearing guide															
Protection class for electrics																
S1	IP65															

Cable outlet direction

With cable outlet at top

With cable outlet at side

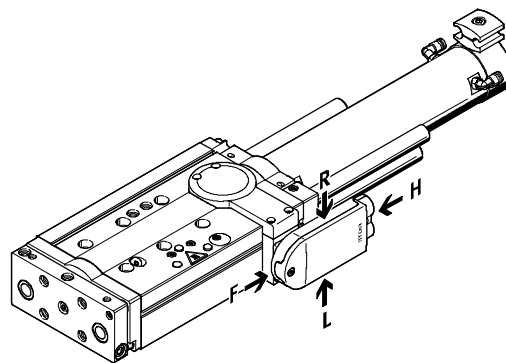
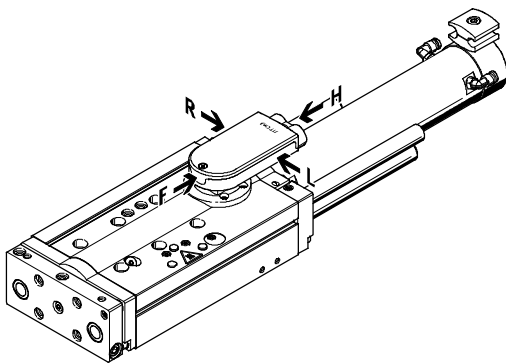

Instructions for use

The guided drive with linear motor is not designed for the following sample applications:

- Magnetic field

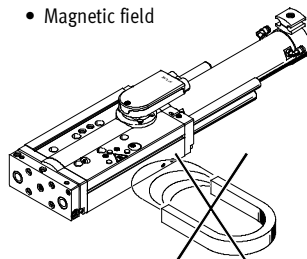

- Welding application

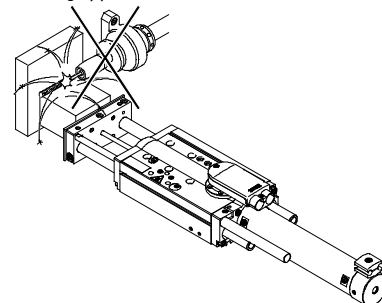

Guided drives DFME-LAS, electric

Peripherals overview

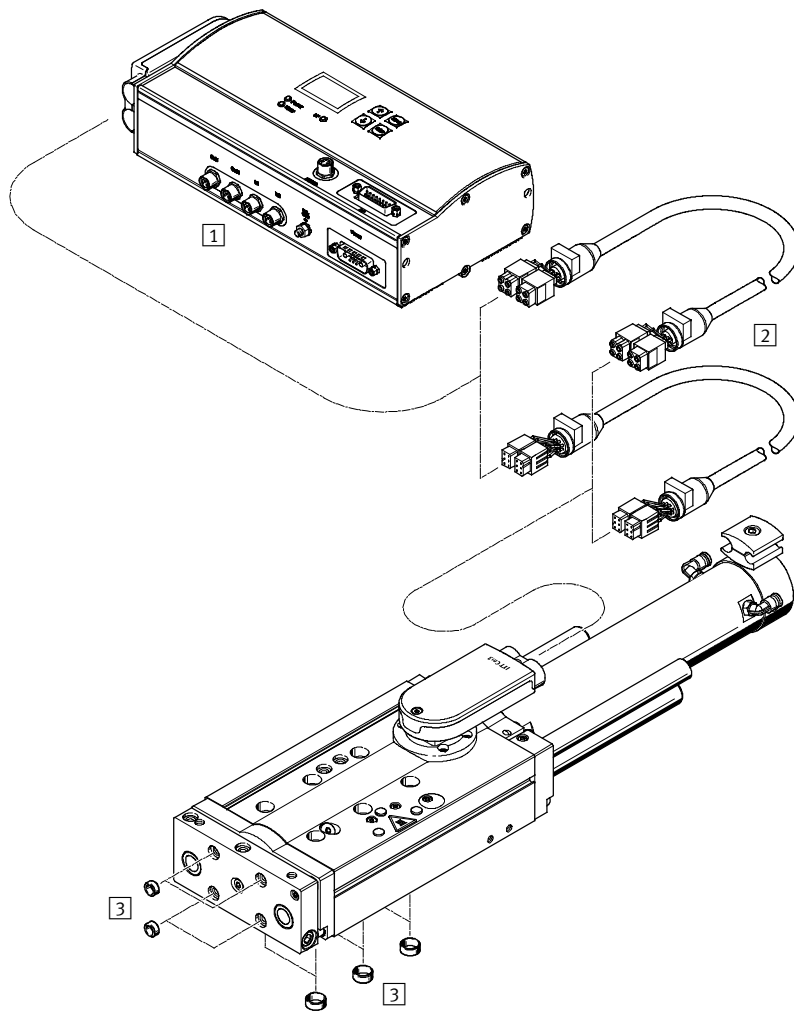

Accessories		
	Brief description	→ Page/Internet
1	Motor controller SFC-LACI	For parameterising and positioning the guided drives sfc-laci
2	Motor/encoder cable NEBM	For connecting the motor and controller sfc-laci
3	Centring sleeve ZBH	For centring loads and attachment components 16

Guided drives DFME-LAS, electric

Technical data

Function

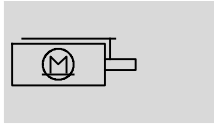

Size
32, 40

Stroke length
100 ... 400 mm

Note
All values are based on a standard temperature of 23 °C. Dynamic response and accuracy are dependent on the mounting (rigidity) and temperature stresses (heat concentration).

www.festo.com

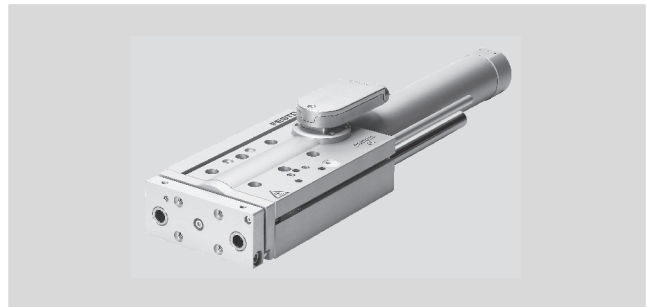

General technical data								
Size	32				40			
Stroke [mm]	100	200	320	100	200	320	400	
Mechanical								
Design	Guided drive Electric linear direct drive							
Guide	Recirculating ball bearing guide							
Drive unit operating mode	Yoke							
Type of mounting	Via female thread and centring sleeve Via through-hole and centring sleeve							
Mounting position	Horizontal							
Stroke reserve [mm]	3.5							
Continuous feed force ¹⁾ [N]	36	29	29	53	40	49	49	
Peak feed force ¹⁾ [N]	94	141	141	183	202	202	202	
Max. effective load ²⁾ [kg]	2	6	4	3.4	6	6	6	
Max. speed [m/s]	2	3	3	2	3	3	3	
Repetition accuracy [mm]	±0.015							
Electric								
Type of motor	Linear AC servo motor							
Displacement encoder	Relative measurement, magnetic, incremental, contactless							
Peak motor current [A]	5.9	16.2	16.2	7.7	22.4	22.4	22.4	
Nominal motor current [A]	2.2	3.3	3.3	2.2	4.4	5.4	5.4	
Rated motor output [W]	108	87	87	159	120	147	147	
Homing	Integrated reference sensor							

1) Disregarding friction

2) Limited by motor power. The values specified here are recommended values

Operating and environmental conditions		
Ambient temperature [°C]	0 ... +40	
Max. motor temperature [°C]	70 (warning at 70 °C, shut-off at 75 °C)	
Standard temperature ¹⁾ [°C]	23	
Temperature monitoring	Shuts off if motor overheats	
Protection class (mechanical system)	IP40	
Protection class (electrical connection)	IP40 (with DFME-...-S1; IP65)	
CE marking (see declaration of conformity)	To EU EMC Directive	

1) Unless otherwise stated, all values are based on standard temperature

Guided drives DFME-LAS, electric

Technical data

Weight [g]								
Size	32				40			
Stroke [mm]	100	200	320	100	200	320	400	
Product weight	4,100	4,900	5,600	6,300	7,000	8,200	8,600	
Moving load	1,030	1,280	1,500	1,620	2,060	2,290	2,520	

Materials

Sectional view

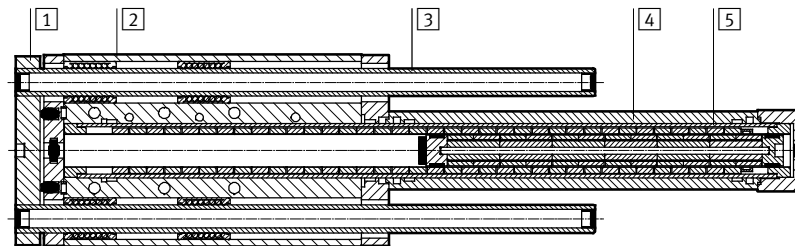

Guided drive	
1 Yoke plate	Anodised wrought aluminium alloy
2 Housing	Anodised wrought aluminium alloy
3 Guide rod	Tempered steel (surface hardened)
4 Cooling tube	Anodised wrought aluminium alloy
5 Piston rod	High-alloy stainless steel
- Terminal strip	Die-cast zinc
- Screws	Steel
- Note on materials	Contains PWIS (paint-wetting impairment substances) RoHS-compliant

Stroke reserve and cushioning length

1 Working stroke:
The recommended, available operating range
L12 Stroke reserve:
The distance from the end positions of the working stroke to the buffers
L10, L11 Cushioning length:
The distance from the buffer surface to the mechanical end position

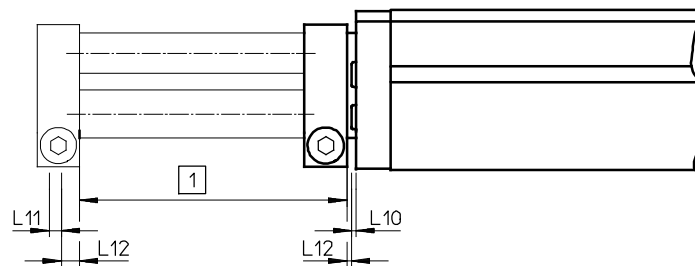

Size	[mm]	Retracted		Advanced	
		L12	L10	L12	L11
32	[mm]	1.75	1.5	1.75	2
40	[mm]	1.75	1.5	1.75	2

Guided drives DFME-LAS, electric

Technical data

Dynamic characteristic load values

Torques are indicated with reference to the centre of the yoke plate. These values must not be exceeded during dynamic operation. Special attention must be paid to the cushioning phase.

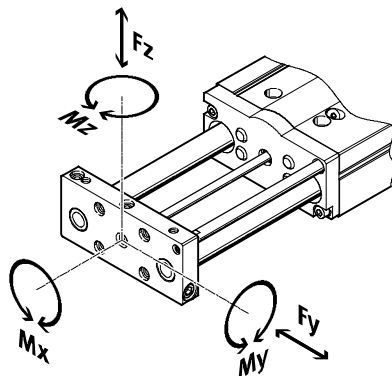

If the drive is simultaneously subjected to several of the indicated forces and torques, the following equation must be satisfied in addition to the indicated maximum loads:

$$\frac{|F_y|}{F_{y_{max}}} + \frac{|F_z|}{F_{z_{max}}} + \frac{|M_x|}{M_{x_{max}}} + \frac{|M_y|}{M_{y_{max}}} + \frac{|M_z|}{M_{z_{max}}} \leq 1$$

Permissible forces and torques							
Size	32			40			
Stroke [mm]	100	200	320	100	200	320	400
F _{ymax} , F _{zmax} [N]	20	60	40	34	60	60	60
M _{xmax} [Nm]	5	4	3	6.3	5.3	4.3	3.3
M _{ymax} [Nm]	2	12	12	3.4	12	19	24
M _{zmax} [Nm]	2	12	12	3.4	12	19	24

- Note

PositioningDrives
sizing software
→ www.festo.com

Piston rod displacement f, with fully advanced piston rod, as a function of stroke l

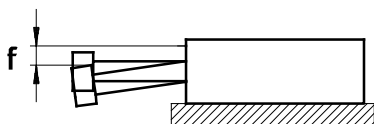

- 2 kg
- - - 4 kg
- · - 6 kg

DFME-32

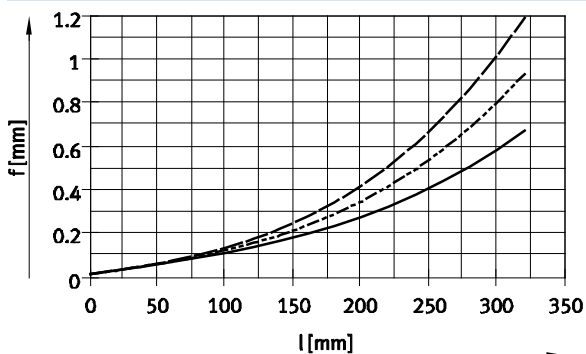

DFME-40

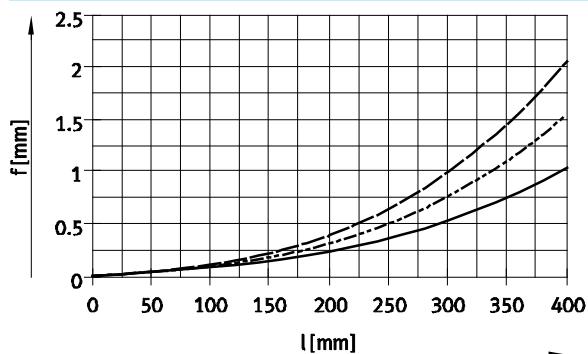

Guided drives DFME-LAS, electric

Technical data



Positioning time t as a function of stroke l , effective load M and duty cycle ED

DFME-32-100

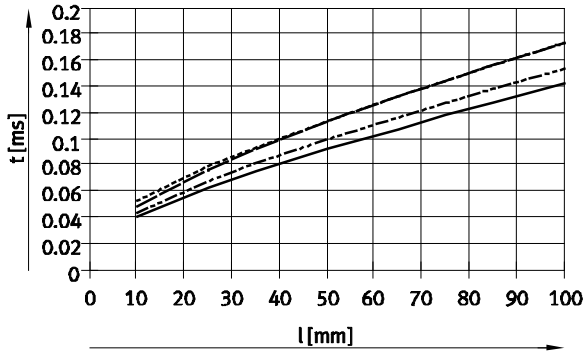

- M 0.5 kg, ED 25% to 50%
- - - M 1.0 kg, ED 25% to 50%
- M 2.0 kg, ED 25%
- - - M 2.0 kg, ED 50%

DFME-32-200

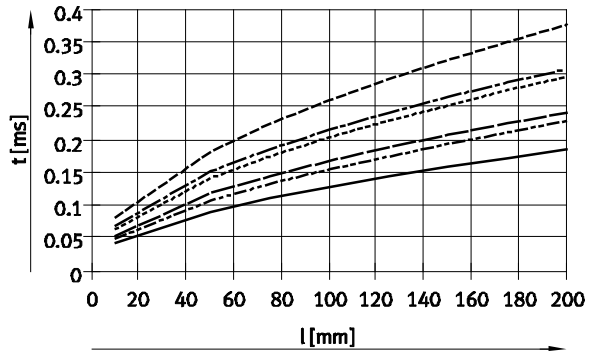

- M 1.0 kg, ED 25%
- - - M 1.0 kg, ED 50%
- M 3.0 kg, ED 25%
- - - M 3.0 kg, ED 50%
- M 6.0 kg, ED 25%
- - - M 6.0 kg, ED 50%

DFME-32-320

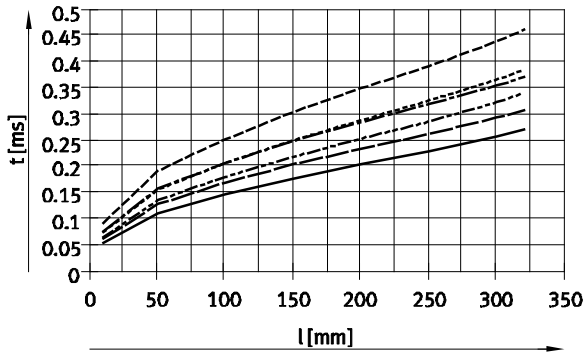

- M 1.0 kg, ED 25%
- - - M 1.0 kg, ED 50%
- M 2.0 kg, ED 25%
- - - M 2.0 kg, ED 50%
- M 4.0 kg, ED 25%
- - - M 4.0 kg, ED 50%

Guided drives DFME-LAS, electric

Technical data

FESTO

Positioning time t as a function of stroke l , effective load M and duty cycle ED

DFME-40-100

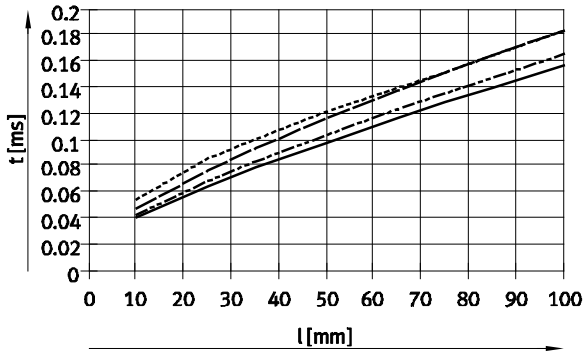

- M 1.0 kg, ED 25% to 50%
- - - M 1.7 kg, ED 25% to 50%
- M 3.4 kg, ED 25%
- - - M 3.4 kg, ED 50%

DFME-40-200

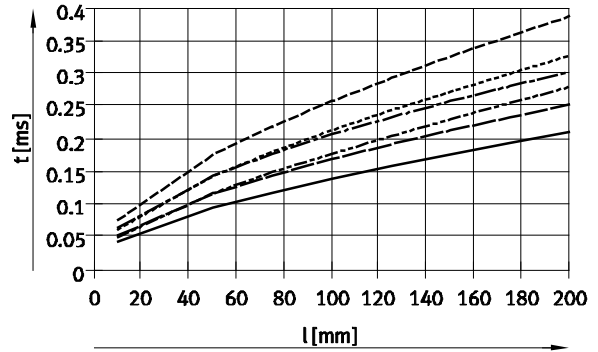

- M 1.0 kg, ED 25%
- - - M 1.0 kg, ED 50%
- M 3.0 kg, ED 25%
- - - M 3.0 kg, ED 50%
- - - M 6.0 kg, ED 25%
- - - M 6.0 kg, ED 50%

DFME-40-320

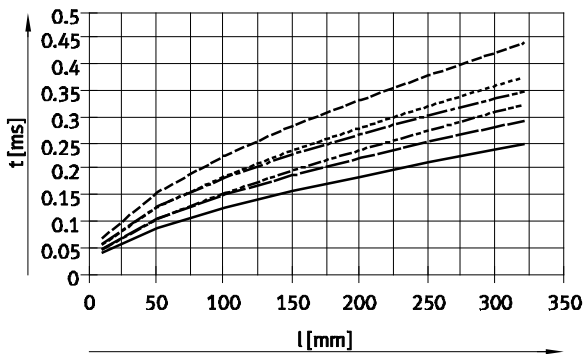

- M 1.0 kg, ED 25%
- - - M 1.0 kg, ED 50%
- M 3.0 kg, ED 25%
- - - M 3.0 kg, ED 50%
- - - M 6.0 kg, ED 25%
- - - M 6.0 kg, ED 50%

DFME-40-400

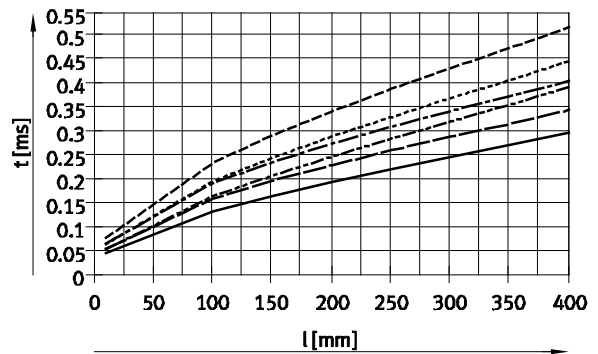

- M 1.0 kg, ED 25%
- - - M 1.0 kg, ED 50%
- M 3.0 kg, ED 25%
- - - M 3.0 kg, ED 50%
- - - M 6.0 kg, ED 25%
- - - M 6.0 kg, ED 50%

Guided drives DFME-LAS, electric

Technical data



Feed force F as a function of stroke l

The graphs are based on practical values with friction taken into account.

Peak feed force
———

Continuous feed force at ambient temperature:
 - - - - - from 23 °C
 ——— from 30 °C
 ······ from 40 °C

DFME-32-100

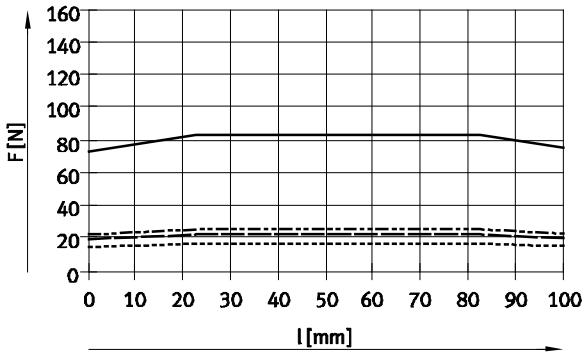

DFME-32-200

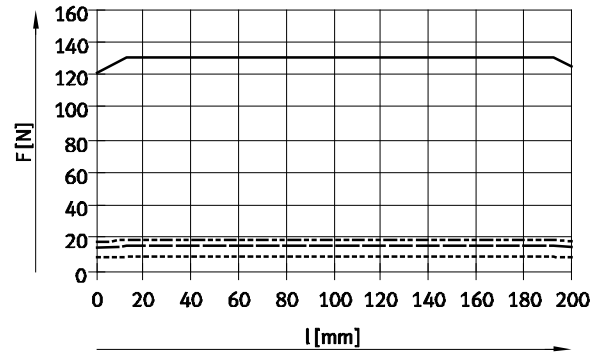

DFME-32-320

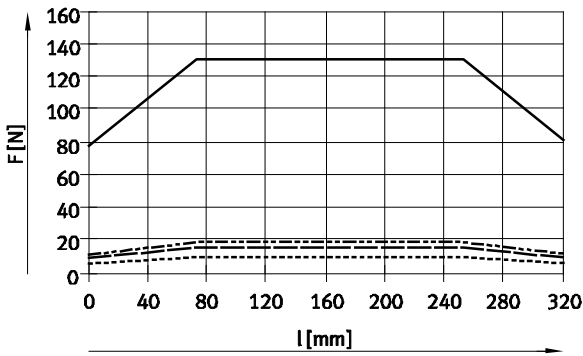

DFME-40-100

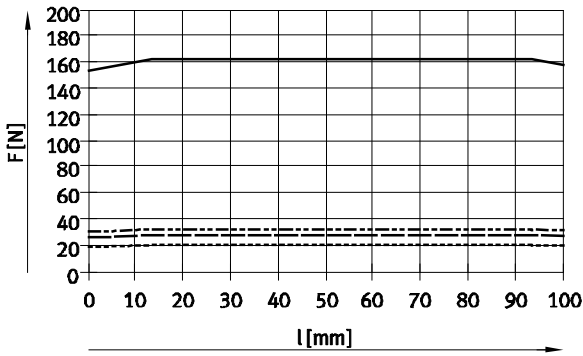

DFME-40-200

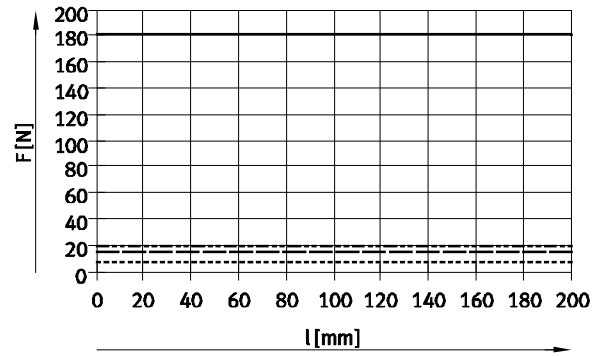

DFME-40-320

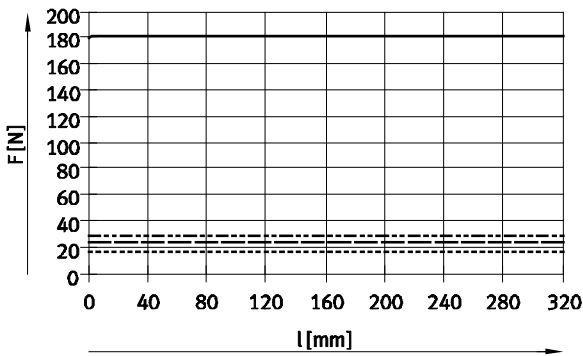

DFME-40-400

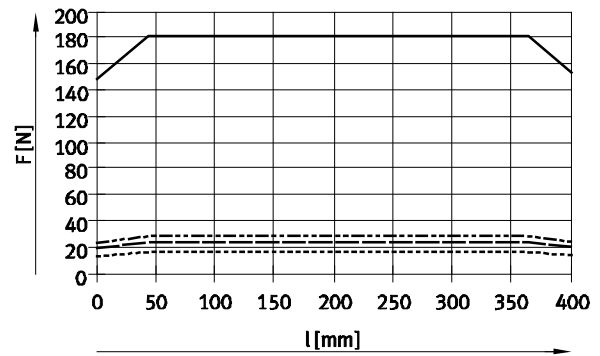

Guided drives DFME-LAS, electric

Technical data

Feed force F as a function of speed v

The graphs are based on practical values under the following conditions:

- Stroke centre of the electric cylinder
- Friction taken into account
- Standard temperature of 23 °C
- Max. motor temperature of 70 °C

Peak feed force
 Continuous feed force

DFME-32-100

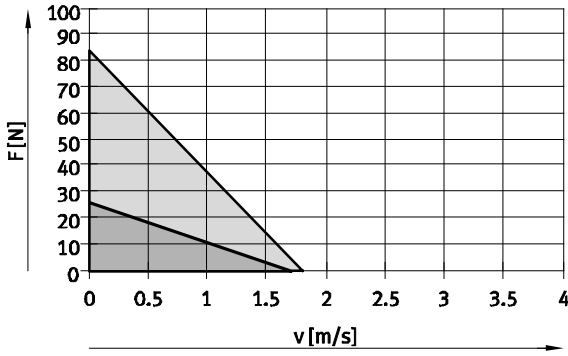

DFME-32-200

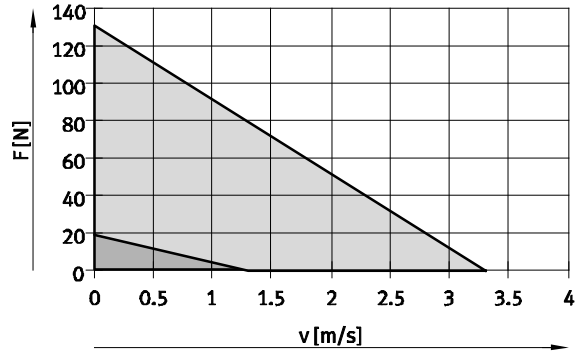

DFME-32-320

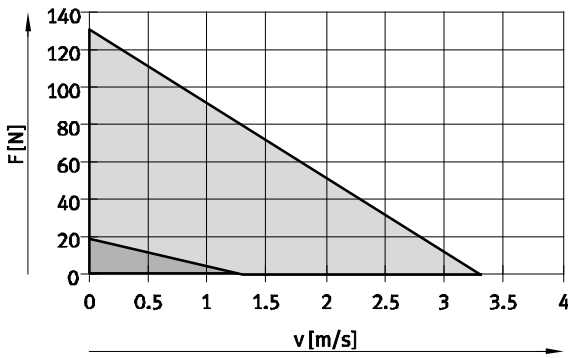

DFME-40-100

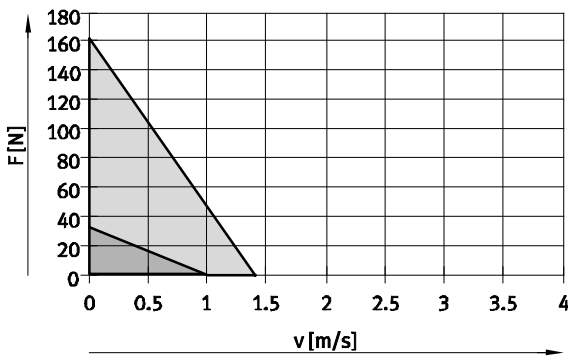

DFME-40-200

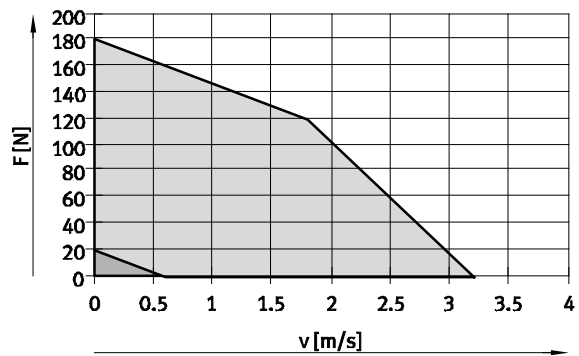

DFME-40-320

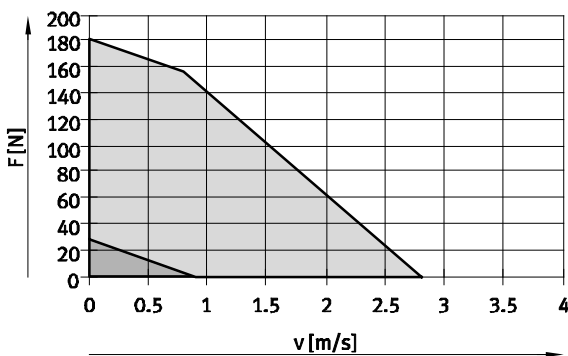

DFME-40-400

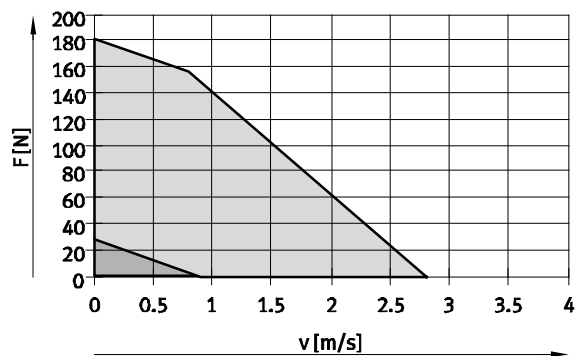

Guided drives DFME-LAS, electric

Technical data

FESTO

Dimensions

Download CAD data → www.festo.com

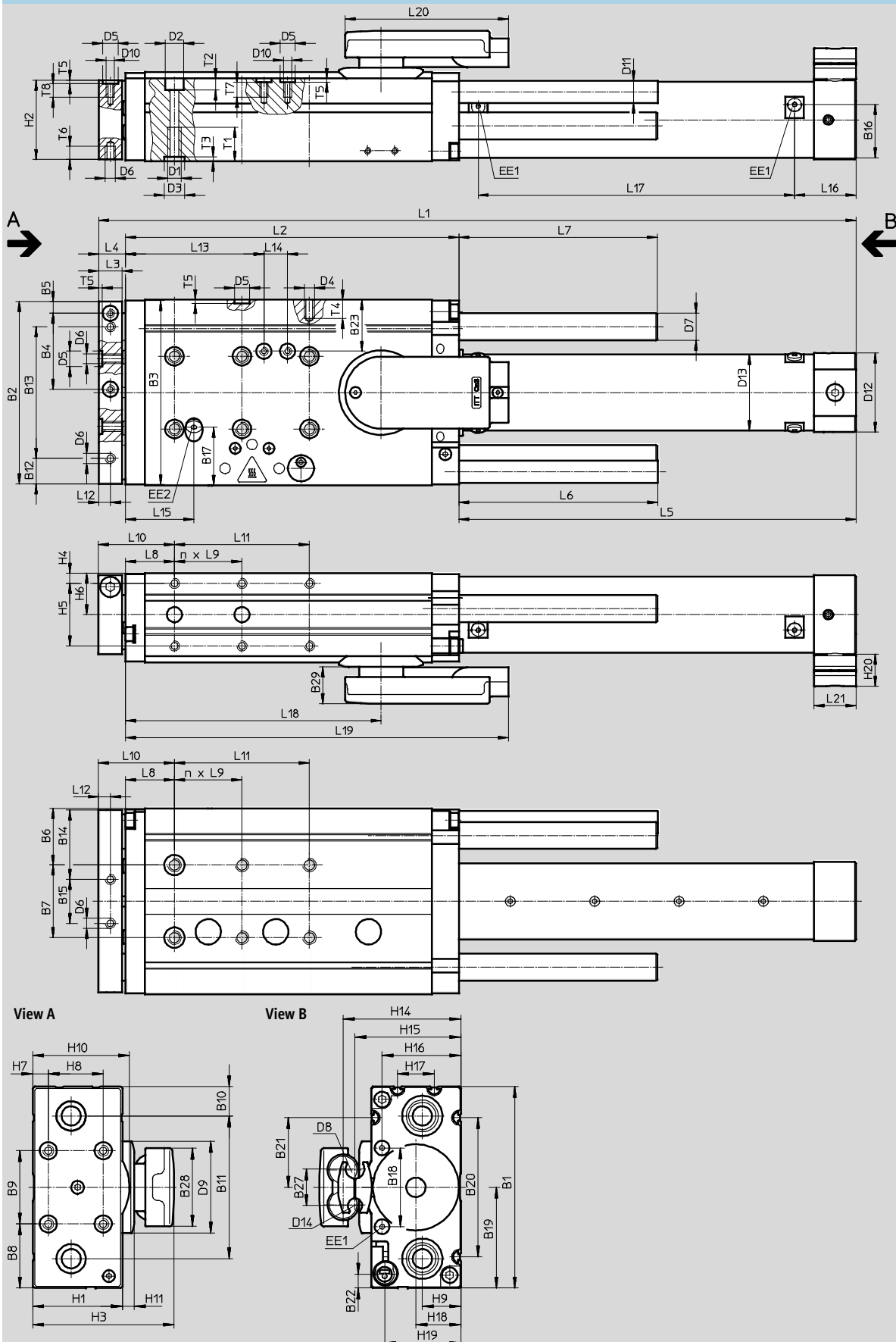

Guided drives DFME-LAS, electric



Technical data

Size	B1	B2	B3	B4 ¹⁾	B5	B6	B7 ¹⁾	B8	B9 ¹⁾	B10	B11	B12
32	110	108	109	45	7	33.5	43	35	40	16	78	15
40	120	118	119	46	6.5	34.5	51	35	50	16	88	15

Size	B13	B14	B15 ¹⁾	B16	B17	B18	B19	B20	B21	B22	B23	B27
32	78	41	26	31.6	34.5	43	55	76	38	8	30.5	20
40	88	41	36	33	36.6	45	60	76	39	8	30.5	20

Size	B28	B29	D1	D2 ∅	D3 ∅ H7	D4	D5 ∅ H7	D6	D7 ∅	D8 ∅	D9 ∅	D10
32	42.6	21.8	M8	11	12	M6	9	M6	16	10.5	50	M5
40	42.6	21.8	M8	11	12	M8	9	M6	16	10.5	50	M5

Size	D11 ∅	D12 ∅	D13 ∅	D14 ∅	EE1	EE2	H1	H2	H3	H4	H5 ¹⁾	H6
32	13.3	47	45	8	M5	M7	49	47	77.3	6	37	24.5
40	13.3	52	50.5	8	M5	M7	54	52	82.8	6	42	27

Size	H7	H8 ¹⁾	H9	H10	H11	H14	H15	H16	H17	H18	H19	H20
32	8.5	30	21	52.9	6.5	64.3	57.9	43	20	24.5	41.6	19
40	10	30	26	59.5	8	70.8	62.7	48.5	20	27	46	19

Size	L2	L3	L4	L8	L9 ¹⁾	L10	L11 ¹⁾	L12	L13	L14 ¹⁾	L15	L16
			-1.75			-1.75						
32	197.5	14	16	29	40	45	80	7	82	14	40.5	36.5
40	227.5	14	16	29	40	45	120	7	85	11.5	42.7	38.5

Size	L18	L19	L20	L21	n	T1	T2	T3	T4	T5	T6	T7	T8
								+0.1		+0.1			
32	151.5	227	96.8	25	1	20	6.8	2.6	11	2.1	8	9	8
40	181.5	257	96.8	25	2	20	6.8	2.6	16	2.1	12	9	10

Size	Stroke [mm]	L1	L5	L6	L7	L17
		-1.75				
32	100	349	135.5	18	17.7	87.5
	200	449	235.5	118	117.7	187.5
	320	569	355.5	238	237.7	307.5
40	100	423.5	180	18	16.7	127.8
	200	523.5	280	118	116.7	227.8
	320	643.5	400	238	236.7	347.8
	400	723.5	480	318	316.7	427.8

1) Tolerance for centring hole ± 0.02 mm
Tolerance for threaded hole ± 0.1 mm

Guided drives DFME-LAS, electric

Technical data



Dimensions

Download CAD data → www.festo.com

DFME-...S – Cable outlet at side

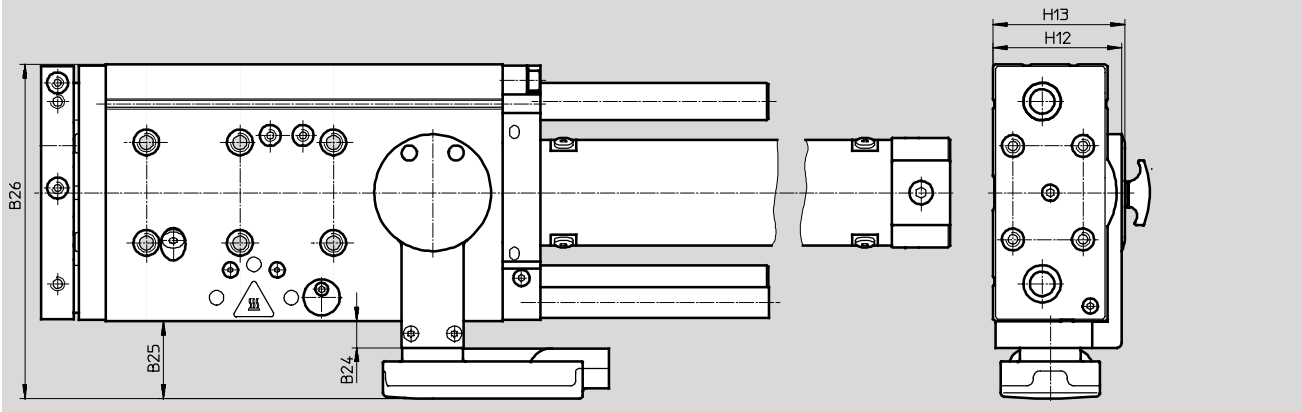

Size	B24	B25	B26	H12	H13
32	11.3	33	143	55	56.5
40	11.3	33	153	61.5	63

Guided drives DFME-LAS, electric

Ordering data – Modular products

Ordering table					
Size	32	40	Condi- tions	Code	Enter code
M Module No.	562828	562829			
Function	Guided drive			DFME	DFME
Size	32	40		-...	
Stroke [mm]	100	100		-...	
	200	200			
	320	320			
	-	400			
Drive type	Linear motor			-L	-L
Motor technology	AC synchronous			AS	AS
Cable outlet	At the top			-T	
	At the side			-S	
Cable outlet direction	To the rear			-H	
	To the front			-F	
	To the left			-L	
	To the right			-R	
Guide	Recirculating ball bearing guide			-KF	-KF
O Protection class for electrics	IP65			-S1	

Transfer order code

Guided drives DFME-LAS, electric

Accessories



Centring sleeve ZBH

Material:
High-alloy steel

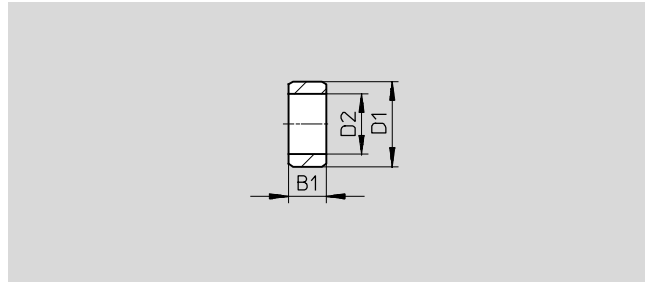

Dimensions and ordering data							
B1	D1	D2	CRC ¹⁾	Weight	Part No.	Type	PU ²⁾
-0.2	∅ h7	∅		[g]			
4	9	6.4	2	1	150927	ZBH-9	10
5	12	10.3	2	1	189653	ZBH-12	10

- 1) Corrosion resistance class 2 according to Festo standard 940 070
Components subject to moderate corrosion stress. Externally visible parts with primarily decorative surface requirements which are in direct contact with a normal industrial environment or media such as coolants or lubricating agents
- 2) Packaging unit quantity