

Linear/swivel clamp CLR

FESTO



Linear/swivel clamp CLR

Key features

Functional description

The linear/swivel clamp CLR is used for all types of clamping. Through the combination of the linear and swivel motion of the piston rod, it is possible to insert and remove workpieces even beyond the clamping range. It is

possible to choose between versions swivelling to the right or to the left, while the CLR also boasts a linear stroke with diameters of 40 and larger.

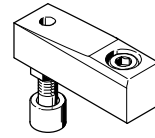

Clamping finger:
Can be ordered as an accessory

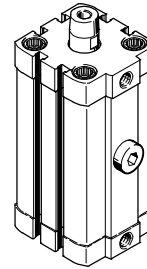

Optimal range

- Uncomplicated mechanical system
- Sturdy design
- Long service life
- Low purchasing, assembly and maintenance costs
- New: CLR with dust and welding spatter protection

Flexible

- Swivel direction can be adjusted subsequently
- Compact dimensions for tight installation spaces

Easy to install

- The port pattern corresponds to ISO 21287, meaning that foot and flange mountings from the standard accessories range can be used
- Female threads in the bearing and end caps enable easy assembly of the cylinder either directly or using mounting accessories

Practical

- Clamping finger including plug-on rubber cap to protect sensitive surfaces available as accessory
- Clamping finger can be freely adjusted across a full 360°
- Can be repaired using set of wearing parts
- Corresponding accessories such as tubing, flow control valves and push-in fittings

Swivel direction



Swivel motion to the right

View from above of the piston rod side with the piston rod retracted. Clockwise swivel direction.



Swivel motion to the left

View from above of the piston rod side with the piston rod retracted. Anticlockwise swivel direction.

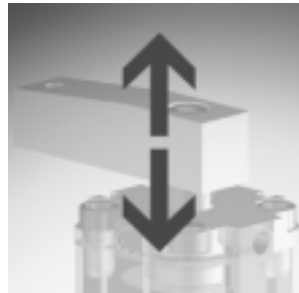

Straight

Linear/swivel clamp CLR

Peripherals overview

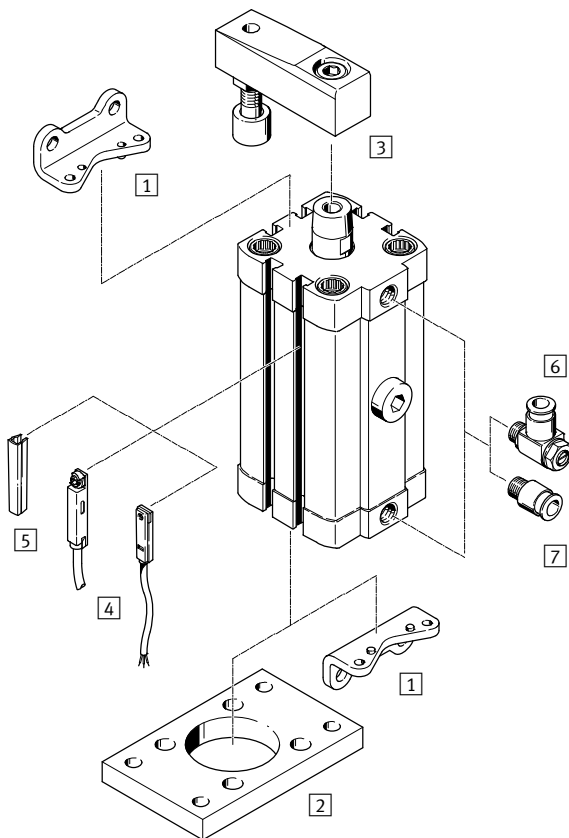

Mounting components and accessories		
	Brief description	→ Page/Internet
1	Foot mounting HNA	For bearing or end caps 14
2	Flange mounting FNC	For end caps 15
3	Clamping finger CLR-...-FS	Comprising clamping finger, mounting screw, tightening bolt, lock nut and dust cap 15
4	Proximity sensor SME/SMT	Can be integrated in the cylinder profile barrel 17
5	Slot cover ABP-5-S	For protecting the sensor cable and keeping dirt out of the sensor slots 17
6	One-way flow control valve GRLA	For speed regulation 16
7	Push-in fitting QS	For connecting compressed air tubing with standard O.D. quick star

Linear/swivel clamp CLR

Type codes

FESTO

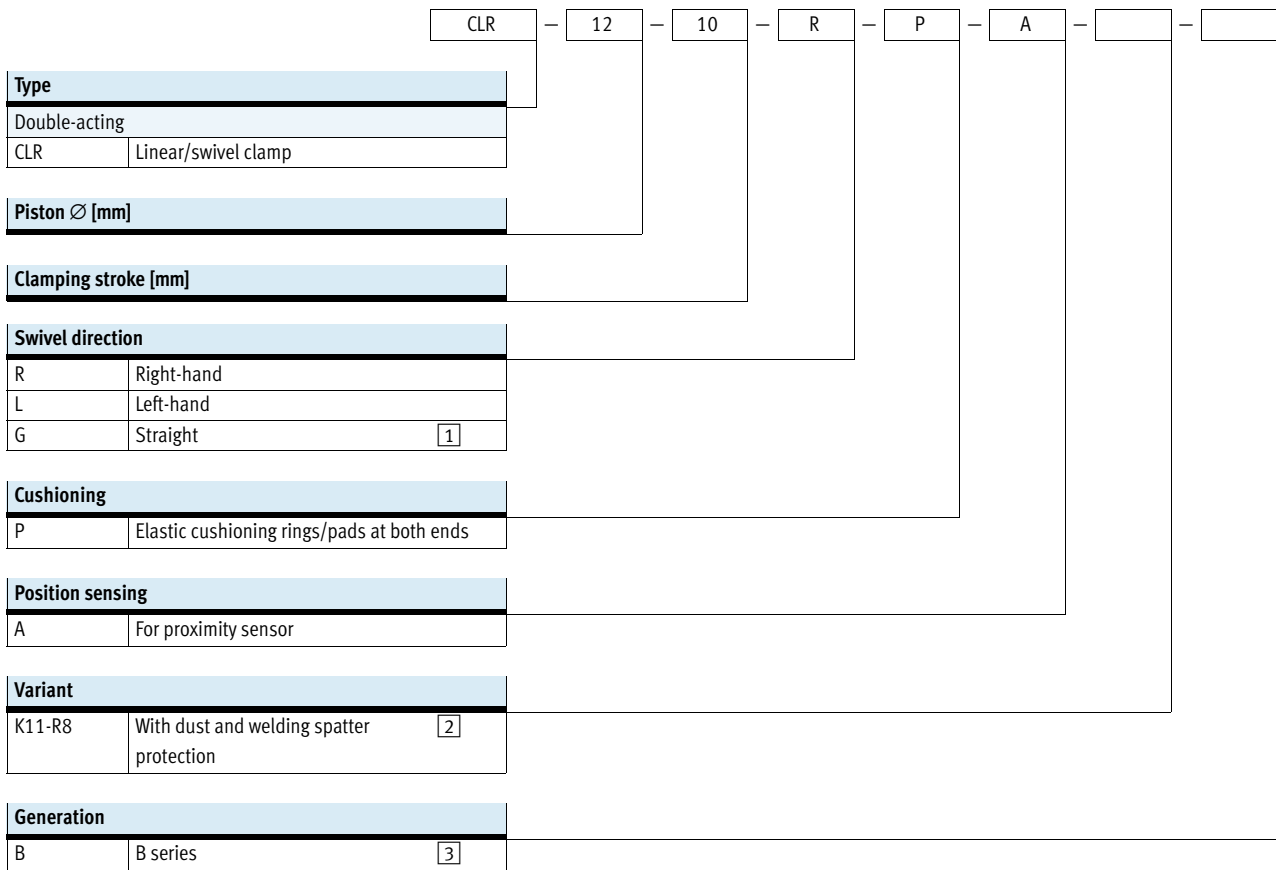

1 Only with piston Ø 40 ... 63 mm

2 Only with piston Ø 25 ... 63 mm

3 Only with piston Ø 32 mm

Linear/swivel clamp CLR

Technical data

Function

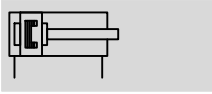

- - Diameter
12 ... 63 mm
- - Clamping stroke
10, 20, 50 mm
- - www.festo.com



General technical data																		
Piston Ø	12	16	20	25	32	40	50	63										
Pneumatic connection	M5	M5	M5	M5	G1/8	G1/8	G1/8	G1/8										
Piston rod thread	M3	M4	M6	M6	M8	M8	M10	M10										
Operating medium	Compressed air to ISO 8573-1:2010 [7:4:4]																	
Note on operating/pilot medium	Lubricated operation possible (in which case lubricated operation will always be required)																	
Design	Piston																	
	Piston rod																	
	Cylinder barrel																	
Cushioning	Elastic cushioning rings/pads at both ends																	
Position sensing	For proximity sensor																	
Type of mounting	With through-hole																	
	With female thread																	
	Via accessories																	
Mounting position	Any																	
Clamping range	≥ 2 mm before the end position is reached																	
Clamping stroke ¹⁾	[mm]	10	20	10	20	10	20	10	20	10	20	10	20	20	50	20	50	
Total stroke ²⁾	[mm]	19	29	20	30	22	32	23	33	28	38	28	38	41	71	43	73	
Swivel direction		Right, left											Right, left, straight					
Swivel angle	[°]	90 ±4			90 ±3				90 ±2									

1) The clamping stroke corresponds to the linear stroke used for clamping
 2) The total stroke comprises the clamping stroke and the swivel stroke

Operating and environmental conditions	
Operating pressure	[bar] 2 ... 10
Ambient temperature ¹⁾	[°C] -10 ... +80
Corrosion resistance class CRC ²⁾	2

1) Note operating range of proximity sensors
 2) Corrosion resistance class 2 according to Festo standard 940 070
 Components subject to moderate corrosion stress. Externally visible parts with primarily decorative surface requirements which are in direct contact with a normal industrial environment or media such as coolants or lubricating agents.

Linear/swivel clamp CLR

Technical data

FESTO

Forces [N] without clamping finger								
Piston Ø	12	16	20	25	32	40	50	63
Theoretical clamping force at 6 bar	51	90	121	227	362	633	990	1,682

Forces [N] with clamping finger CLR-...-FS, 5 mm before end of stroke									
Piston Ø	12	16	20	25	32	40	50	63	
Effective clamping force at	2 bar	12	17	35	63	111	176	271	441
	4 bar	23	36	73	127	216	355	508	823
	6 bar	34	53	109	188	313	536	716	1,386

Materials

Sectional view

Basic design

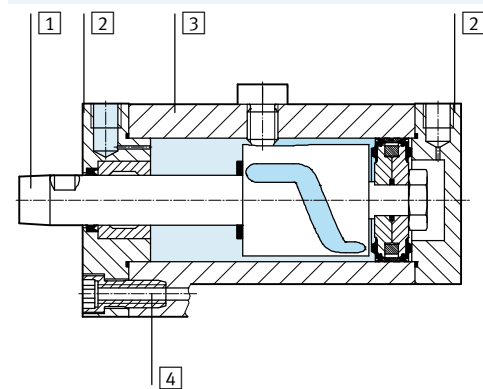

K11-R8 With dust and welding spatter protection

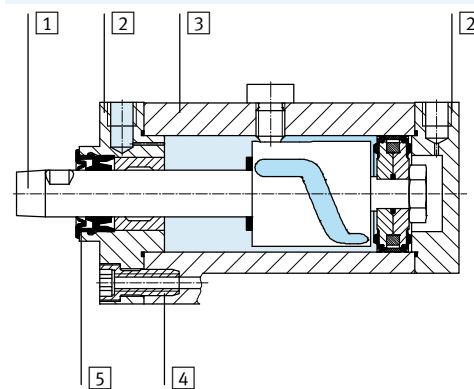

Linear/swivel clamp	Basic design	K11-R8
1 Piston rod	High-alloy stainless steel	Surface-treated high-alloy stainless steel
2 Bearing and end caps	Coated wrought aluminium alloy	
3 Cylinder barrel	Smooth anodised wrought aluminium alloy	
4 Flange screws	Galvanised steel	
5 Hard scraper	-	Polyphenylene sulphide, flame-retardant
- Seals	Nitrile rubber, polyurethane	

Weight [g]									
Piston Ø	12	16	20	25	32	40	50	63	
Basic design									
Product weight at stroke	10 mm	135	160	335	395	685	880	-	-
	20 mm	160	190	385	455	765	985	1,650	2,100
	50 mm	-	-	-	-	-	-	2,115	2,635
Variant K11-R8									
Product weight at stroke	10 mm	-	-	-	410	700	895	-	-
	20 mm	-	-	-	470	785	1,010	1,690	2,100
	50 mm	-	-	-	-	-	-	2,155	2,625

Linear/swivel clamp CLR

Technical data

Maximum permissible mass moment of inertia J_0

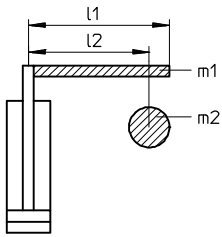

- m_1 = mass of the clamping finger
- l_1 = length of the clamping finger
- m_2 = mass of the screw
- l_2 = centre distance between screw and piston rod

Note
 The permissible mass moment of inertia at the piston rod depends on the cylinder's speed. The moment can easily be calculated using this formula. The software program "mass moments of inertia", available on the electronic catalogue, can also be used for calculation purposes.

Maximum permissible mass moment of inertia:

$$J_0 = \frac{m_1 \times l_1^2}{3} + m_2 \times l_2^2$$

Mass moment of inertia J as a function of the time t required for a single stroke

Ø 12

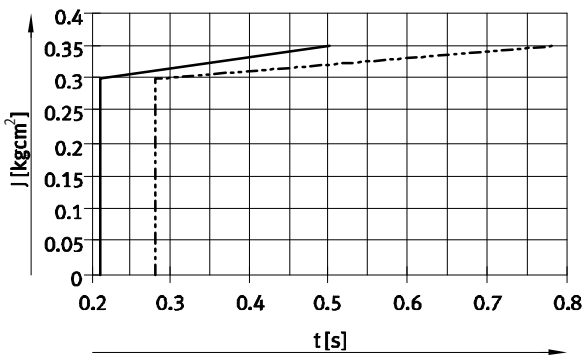

- 10 mm stroke
- - - 20 mm stroke

Ø 16

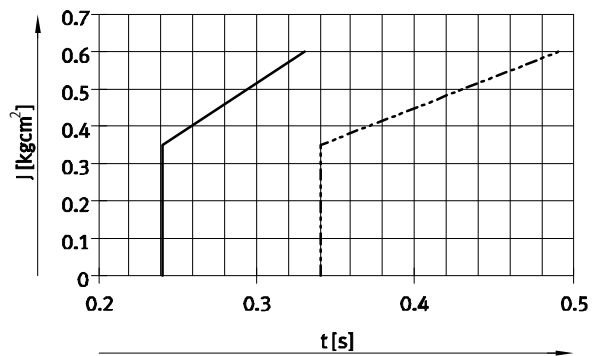

Ø 20

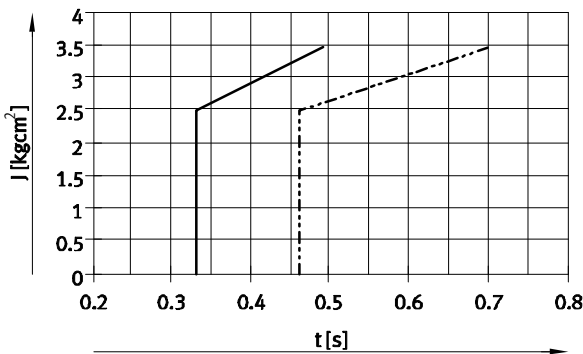

- 10 mm stroke
- - - 20 mm stroke

Ø 25

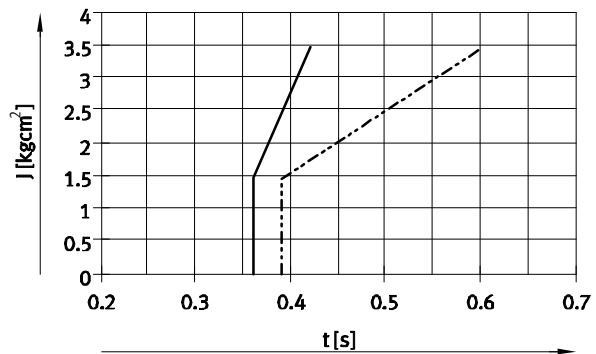

Linear/swivel clamp CLR

Technical data

Maximum permissible mass moment of inertia J_0

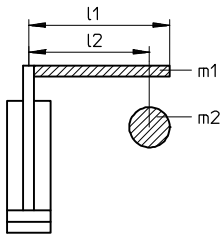

- m_1 = mass of the clamping finger
- l_1 = length of the clamping finger
- m_2 = mass of the screw
- l_2 = centre distance between screw and piston rod

Note

The permissible mass moment of inertia at the piston rod depends on the cylinder's speed. The moment can easily be calculated using this

formula. The software program "mass moments of inertia", available on the electronic catalogue, can also be used for calculation purposes.

Maximum permissible mass moment of inertia:

$$J_0 = \frac{m_1 \times l_1^2}{3} + m_2 \times l_2^2$$

Mass moment of inertia J as a function of the time t required for a single stroke

Ø 32

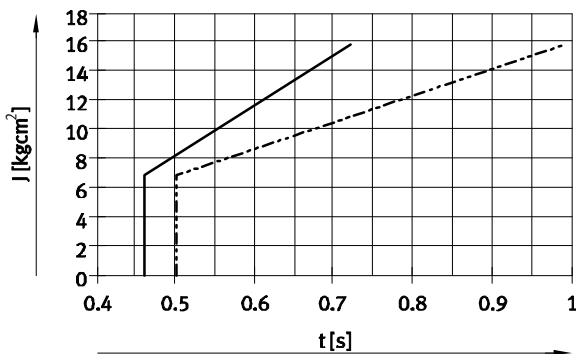

- 10 mm stroke
- - - 20 mm stroke

Ø 40

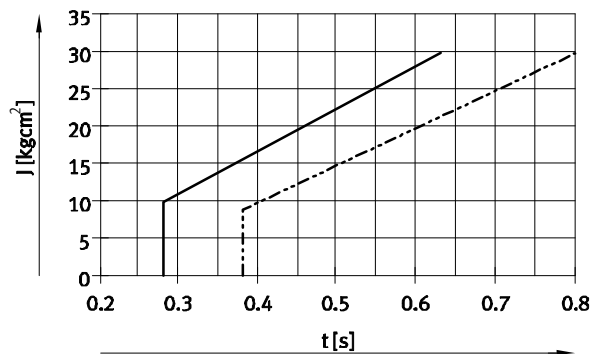

Ø 50

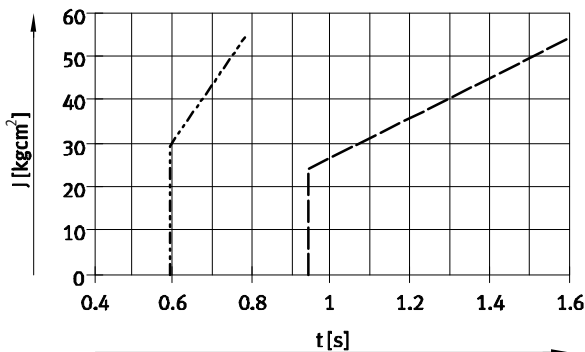

- - - 20 mm stroke
- 50 mm stroke

Ø 63

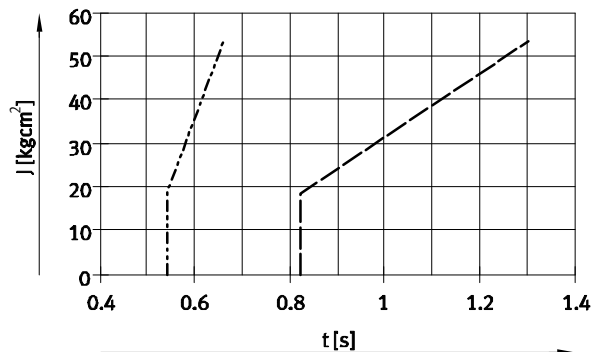

Linear/swivel clamp CLR

Technical data

Assembling a clamping finger

Step 1

- Place the clamping finger on the cone of the piston rod
- Screw the mounting screw into the threaded hole of the piston rod until the clamping finger can still just be turned

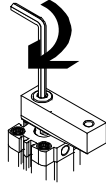

Step 2

- Hold the piston rod in place at the spanner flat using a spanner
- Turn the clamping finger with a second spanner until the alignment corresponds to the application

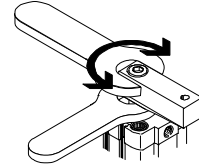

Step 3

- Tighten the mounting screw using the tightening torque below

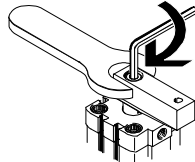

Tightening torques [Nm]

Piston \varnothing	12	16	20	25	32	40	50	63
Max. tightening torque clamping finger screw	1.2	3	12	12	24	24	47	47

Note

No calculations are required when using the Festo clamping finger. The accessory is matched to the cylinder and can be operated without flow control at the maximum permissible

pressure. When manufacturing the clamping finger in-house, the following values must be checked and calculations performed.

Maximum permissible clamping arm length l as a function of the operating pressure p

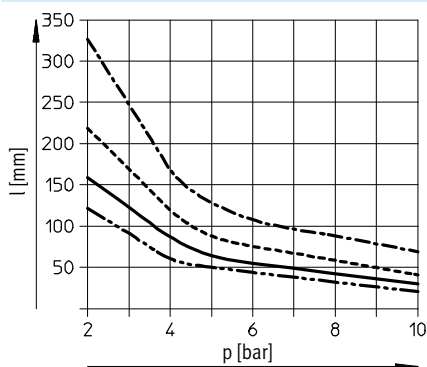

\varnothing 12/16
 \varnothing 20/25
 \varnothing 32/40
 \varnothing 50/63

Linear/swivel clamp CLR

Technical data

FESTO

Dimensions

Download CAD data → www.festo.com

Basic design Ø 12 ... 63

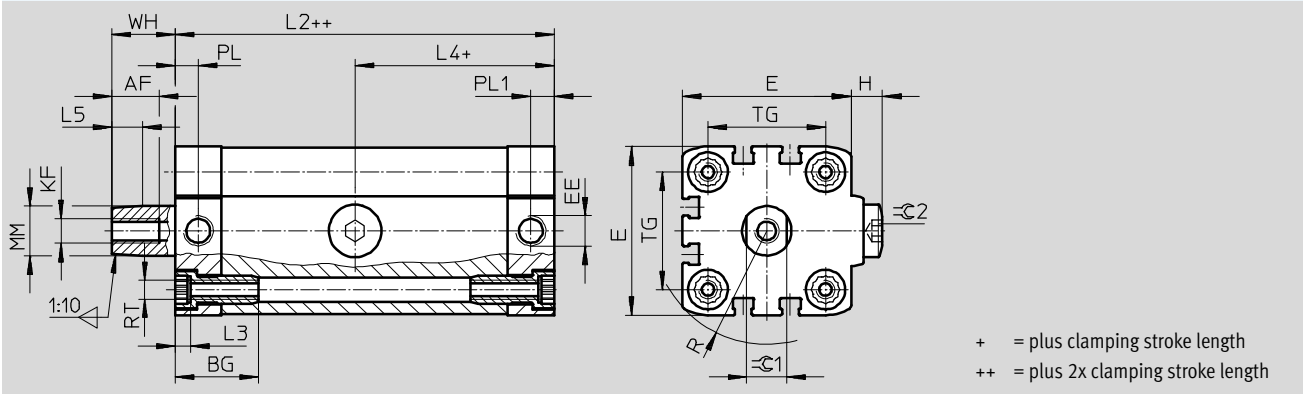

Variant K11-R8 Ø 25 ... 63

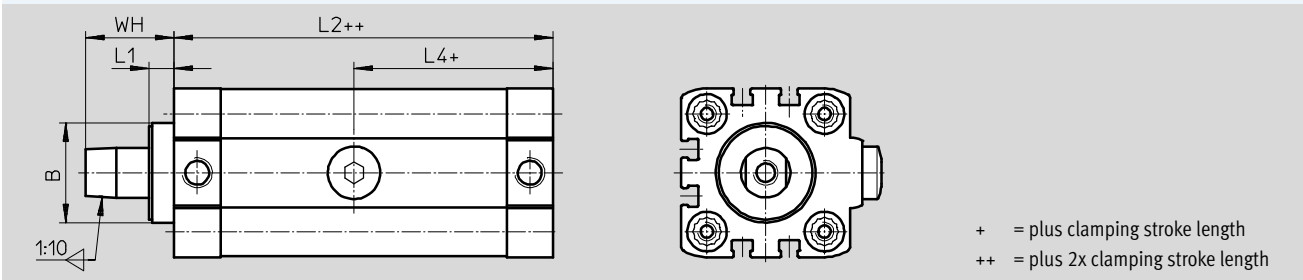

Ø	AF	BG	B	E	EE	H	KF	L1	L2	L3	L4
[mm]											
12	10	17	-	27.5	M5	3.25	M3	-	60.6	3.5	21.8
16	12			29			M4		62.5		23.5
20	15	19.5	28.4	35.5		4.75	M6	8.1	79.5	4.6	43.8
25			39.5	82.5					46.55		
32		26	32.2	47	8.9	M8	101		53.05		
40	27	38.2	54.5	10.15	102.5		54.3				
50			65.5	12.7	117.9	58.8					
63			75.5	14.2	124.9	62.75					

Ø	L5	MM Ø	PL	PL1	R	RT	TG	WH		⊕C1	⊕C2
[mm]									K11-R8		
12	4.9	6	6	15.1	18.2	M4	16	10.9	-	5	3
16		8	6.5	15	19.3		18			7	
20	7.4	12	6	6	23.7	M5	22	16.4	24.5	10	5
25							26.3				
32	9.9	16	7.5	7.5	31.5	M6	32.5	20.4	28.5	13	6
40							36.7				
50	10.3	20			44.3	M8	46.5	20.8		17	8
63							51.5				

Linear/swivel clamp CLR

Technical data

FESTO

Ordering data – Swivel direction right				
Type	Piston Ø [mm]	Stroke [mm]	Part No.	Type
	12	10	535431	CLR-12-10-R-P-A
		20	535433	CLR-12-20-R-P-A
	16	10	535435	CLR-16-10-R-P-A
		20	535437	CLR-16-20-R-P-A
	20	10	535439	CLR-20-10-R-P-A
		20	535441	CLR-20-20-R-P-A
	25	10	535443	CLR-25-10-R-P-A
		20	535445	CLR-25-20-R-P-A
	32	10	543177	CLR-32-10-R-P-A-B
		20	543179	CLR-32-20-R-P-A-B
	40	10	535453	CLR-40-10-R-P-A
		20	535456	CLR-40-20-R-P-A
	50	20	535459	CLR-50-20-R-P-A
		50	535462	CLR-50-50-R-P-A
	63	20	535465	CLR-63-20-R-P-A
		50	535468	CLR-63-50-R-P-A

Ordering data – Swivel direction right, with dust and welding spatter protection				
Type	Piston Ø [mm]	Stroke [mm]	Part No.	Type
	25	10	535483	CLR-25-10-R-P-A-K11-R8
		20	535485	CLR-25-20-R-P-A-K11-R8
	32	10	535487	CLR-32-10-R-P-A-B-K11-R8
		20	535490	CLR-32-20-R-P-A-B-K11-R8
	40	10	535493	CLR-40-10-R-P-A-K11-R8
		20	535496	CLR-40-20-R-P-A-K11-R8
	50	20	535499	CLR-50-20-R-P-A-K11-R8
		50	535502	CLR-50-50-R-P-A-K11-R8
	63	20	535505	CLR-63-20-R-P-A-K11-R8
		50	535508	CLR-63-50-R-P-A-K11-R8

Linear/swivel clamp CLR

Technical data

Ordering data – Swivel direction left				
Type	Piston Ø [mm]	Stroke [mm]	Part No.	Type
	12	10	535432	CLR-12-10-L-P-A
		20	535434	CLR-12-20-L-P-A
	16	10	535436	CLR-16-10-L-P-A
		20	535438	CLR-16-20-L-P-A
	20	10	535440	CLR-20-10-L-P-A
		20	535442	CLR-20-20-L-P-A
	25	10	535444	CLR-25-10-L-P-A
		20	535446	CLR-25-20-L-P-A
	32	10	543178	CLR-32-10-L-P-A-B
		20	543180	CLR-32-20-L-P-A-B
	40	10	535454	CLR-40-10-L-P-A
		20	535457	CLR-40-20-L-P-A
	50	20	535460	CLR-50-20-L-P-A
		50	535463	CLR-50-50-L-P-A
	63	20	535466	CLR-63-20-L-P-A
		50	535469	CLR-63-50-L-P-A

Ordering data – Swivel direction left, with dust and welding spatter protection				
Type	Piston Ø [mm]	Stroke [mm]	Part No.	Type
	25	10	535484	CLR-25-10-L-P-A-K11-R8
		20	535486	CLR-25-20-L-P-A-K11-R8
	32	10	535488	CLR-32-10-L-P-A-B-K11-R8
		20	535491	CLR-32-20-L-P-A-B-K11-R8
	40	10	535494	CLR-40-10-L-P-A-K11-R8
		20	535497	CLR-40-20-L-P-A-K11-R8
	50	20	535500	CLR-50-20-L-P-A-K11-R8
		50	535503	CLR-50-50-L-P-A-K11-R8
	63	20	535506	CLR-63-20-L-P-A-K11-R8
		50	535509	CLR-63-50-L-P-A-K11-R8

Linear/swivel clamp CLR

Technical data

FESTO

Ordering data – Swivel direction straight				
Type	Piston Ø [mm]	Stroke [mm]	Part No.	Type
	40	10	535455	CLR-40-10-G-P-A
		20	535458	CLR-40-20-G-P-A
	50	20	535461	CLR-50-20-G-P-A
		50	535464	CLR-50-50-G-P-A
	63	20	535467	CLR-63-20-G-P-A
		50	535470	CLR-63-50-G-P-A

Ordering data – Swivel direction straight, with dust and welding spatter protection				
Type	Piston Ø [mm]	Stroke [mm]	Part No.	Type
	40	10	535495	CLR-40-10-G-P-A-K11-R8
		20	535498	CLR-40-20-G-P-A-K11-R8
	50	20	535501	CLR-50-20-G-P-A-K11-R8
		50	535504	CLR-50-50-G-P-A-K11-R8
	63	20	535507	CLR-63-20-G-P-A-K11-R8
		50	535510	CLR-63-50-G-P-A-K11-R8

 Note

The swivel direction can easily be adjusted subsequently.
 E.g.: A CLR-12-10-R-P-A with right-hand swivel can be converted to the left-hand swivel variant CLR-12-10-L-P-A by loosening the guide pin and rotating the slotted guide plate.

Linear/swivel clamp CLR

Accessories



Foot mounting HNA

Materials:

Galvanised steel
Free of copper and PTFE
RoHS-compliant

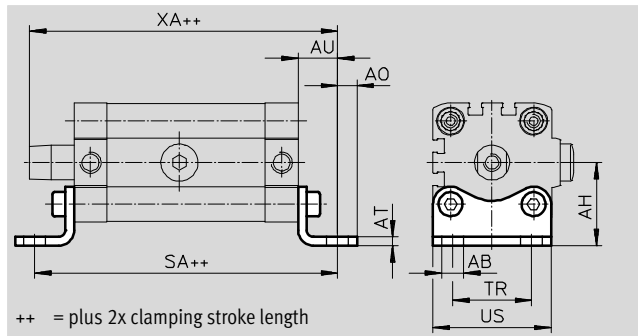

Dimensions and ordering data													
For \varnothing [mm]	AB \varnothing H14	AH	AO	AT	AU	SA	TR	US	XA	CRC ¹⁾	Weight [g]	Part No.	Type
12	5.8	21	5	3	13	86.6	16	26	84.5	1	39	537237	HNA-12
16		22	4.75			88.5	18	27.5	86.4	1	42	537238	HNA-16
20	7	27	6.25	4	16	111.5	22	34.5	111.9	1	84	537239	HNA-20
25		29				114.5	26	38.5	114.9	1	90	537240	HNA-25
32		33.5				133	32	46	137.4	1	123	537241	HNA-32
40	10	38	9	5	21	138.5	36	54	140.9	1	157	537242	HNA-40
50		45	8			159.5	45	64	159.7	1	278	537243	HNA-50
63		50	166.9			50	75	166.7	1	328	537244	HNA-63	

1) Corrosion resistance class 1 according to Festo standard 940 070
Components subject to low corrosion stress. Transport and storage protection. Parts that do not have primarily decorative surface requirements, e.g. in internal areas that are not visible or behind covers.

-  - Note
The foot mounting HNA can only be used for the variant K11-R8 with a diameter of 40 or over.

Linear/swivel clamp CLR

Accessories



Flange mounting FNC

Materials:

Galvanised steel

Free of copper and PTFE

RoHS-compliant

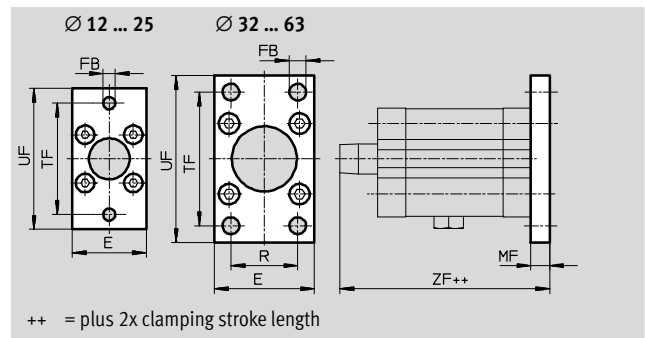

Dimensions and ordering data											
For Ø	E	FB	MF	R	TF	UF	ZF	CRC ¹⁾	Weight	Part No.	Type
[mm]		Ø							[g]		
12	28	5.5	8	-	40	50	79.5	1	79	537245	FNC-12
16	29				43	55	81.4	1	88	537246	FNC-16
20	36				55	70	103.9	1	141	537247	FNC-20
25	40	6.6			60	76	106.9	1	165	537248	FNC-25
32	45	7	10	32	64	80	131.4	1	221	174376	FNC-32
40	54	9		36	72	90	132.9	1	291	174377	FNC-40
50	65	12		45	90	110	150.7	1	536	174378	FNC-50
63	75		50	100	120	157.7	1	679	174379	FNC-63	

1) Corrosion resistance class 1 according to Festo standard 940 070

Components subject to low corrosion stress. Transport and storage protection. Parts that do not have primarily decorative surface requirements, e.g. in internal areas that are not visible or behind covers.

Clamping finger CLR...-FS

Materials: clamping finger:

12 ... 40: anodised aluminium

50 ... 63: high-alloy stainless steel

Mounting screw, tightening bolt, lock

nut: galvanised steel

Dust cap: neoprene

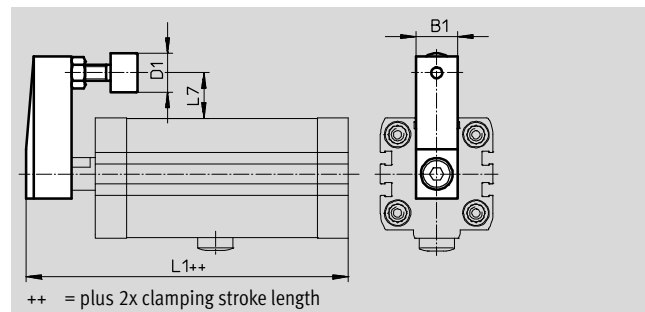





For Ø	B1	D1	L1		L7	Part No.	Type
[mm]		Ø	Basic design	K11-R8			
12	10	11	76.5	-	11.8	535551	CLR-12-FS
16	11		79.4		12.25	535552	CLR-16-FS
20	16		104.4		17.5	535553	CLR-20/25-FS
25		107.4	115.5	15.5	535554	CLR-32/40-FS	
32	20	133.3	141.4	25.75			
40		134.8	142.9	22			
50	25	24	153.2	160.85	32.5	535555	CLR-50/63-FS
63			160.2	167.85	27.5		

Linear/swivel clamp CLR

Accessories

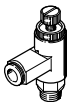
FESTO

Ordering data – One-way flow control valves				Technical data → Internet: grl	
	Connection		Material	Part No.	Type
	Thread	For tubing O.D. [mm]			
For exhaust air					
	M5	3	Metal design	193137	GRLA-M5-QS-3-D
		4		193138	GRLA-M5-QS-4-D
		6		193139	GRLA-M5-QS-6-D
	G1/8	3		193142	GRLA-1/8-QS-3-D
		4		193143	GRLA-1/8-QS-4-D
		6		193144	GRLA-1/8-QS-6-D
		8		193145	GRLA-1/8-QS-8-D
		For exhaust air			
	G1/8	4	Metal design	195597	GRLA-F-1/8-QS-4-D
		6		195598	GRLA-F-1/8-QS-6-D
		8		195599	GRLA-F-1/8-QS-8-D
For exhaust air					
	G1/8	6	Metal design	162965	GRLA-1/8-QS-6-RS-B
		8		162966	GRLA-1/8-QS-8-RS-B
For supply air					
	M5	3	Metal design	193153	GRLZ-M5-QS-3-D
		4		193154	GRLZ-M5-QS-4-D
		6		193155	GRLZ-M5-QS-6-D
	G1/8	3		193156	GRLZ-1/8-QS-3-D
		4		193157	GRLZ-1/8-QS-4-D
		6		193158	GRLZ-1/8-QS-6-D
		8		193159	GRLZ-1/8-QS-8-D

Ordering data – One-way flow control valves				Technical data → Internet: grla	
	Connection		Material	Part No.	Type
	Thread ¹⁾	For tubing I.D. [mm]			
For exhaust air					
	M5	3	Metal design	151161	GRLA-M5-PK-3-B
		4		151162	GRLA-M5-PK-4-B
	G1/8	3		151166	GRLA-1/8-PK-3-B
		4		151167	GRLA-1/8-PK-4-B
		6		151168	GRLA-1/8-PK-6-B



1) Union nut for barbed connector only with screw-in thread G1/8



Ordering data – Tubing			Technical data → Internet: pun	
	Flame-retardant	Material		
	Standard O.D. tubing	For use in the immediate vicinity of welding applications	Polyurethane	PUN-V0



Linear/swivel clamp CLR

Accessories

FESTO

Ordering data – Proximity sensor for T-slot, magneto-resistive						Technical data → Internet: smt
	Type of mounting	Switching output	Electrical connection	Cable length [m]	Part No.	Type
N/O contact						
	Inserted in the slot from above, flush with the cylinder profile, short design	PNP	Cable, 3-wire	2.5	574335	SMT-8M-A-PS-24V-E-2,5-OE
			Plug M8x1, 3-pin	0.3	574334	SMT-8M-A-PS-24V-E-0,3-M8D
			Plug M12x1, 3-pin	0.3	574337	SMT-8M-A-PS-24V-E-0,3-M12
		NPN	Cable, 3-wire	2.5	574338	SMT-8M-A-NS-24V-E-2,5-OE
			Plug M8x1, 3-pin	0.3	574339	SMT-8M-A-NS-24V-E-0,3-M8D
N/C contact						
	Inserted in the slot from above, flush with the cylinder profile, short design	PNP	Cable, 3-wire	7.5	574340	SMT-8M-A-PO-24V-E-7,5-OE

Ordering data – Proximity sensors for T-slot, magnetic reed						Technical data → Internet: sme		
	Type of mounting	Switching output	Electrical connection	Cable length [m]	Part No.	Type		
N/O contact								
	Inserted in the slot from above, flush with the cylinder profile	Contacting	Cable, 3-wire	2.5	543862	SME-8M-DS-24V-K-2,5-OE		
				5.0	543863	SME-8M-DS-24V-K-5,0-OE		
			Plug M8x1, 3-pin	Cable, 2-wire	2.5	543872	SME-8M-ZS-24V-K-2,5-OE	
				Plug M8x1, 3-pin	Cable, 3-wire	0.3	543861	SME-8M-DS-24V-K-0,3-M8D
					Cable, 3-wire	2.5	150855	SME-8-K-LED-24
	Insertable in the slot lengthwise, flush with the cylinder profile	Contacting	Plug M8x1, 3-pin	0.3	150857	SME-8-S-LED-24		
				N/C contact				
	Insertable in the slot lengthwise, flush with the cylinder profile	Contacting	Cable, 3-wire	7.5	160251	SME-8-0-K-LED-24		

Ordering data – Connecting cables					Technical data → Internet: nebu
	Electrical connection, left	Electrical connection, right	Cable length [m]	Part No.	Type
	Straight socket, M8x1, 3-pin	Cable, open end, 3-wire	2.5	541333	NEBU-M8G3-K-2.5-LE3
			5	541334	NEBU-M8G3-K-5-LE3
	Straight socket, M12x1, 5-pin	Cable, open end, 3-wire	2.5	541363	NEBU-M12G5-K-2.5-LE3
			5	541364	NEBU-M12G5-K-5-LE3
	Angled socket, M8x1, 3-pin	Cable, open end, 3-wire	2.5	541338	NEBU-M8W3-K-2.5-LE3
			5	541341	NEBU-M8W3-K-5-LE3
	Angled socket, M12x1, 5-pin	Cable, open end, 3-wire	2.5	541367	NEBU-M12W5-K-2.5-LE3
			5	541370	NEBU-M12W5-K-5-LE3

Ordering data – Slot cover for T-slot					
	Mounting	Length [m]	Part No.	Type	
	Inserted from above	2x 0.5	151680	ABP-5-S	