

Slide units SPZ, twin piston



Slide units SPZ, twin piston

Key features

Multi-axis and drive combinations

The slide unit SPZ can be combined with different drives. An adapter kit is required for mounting between the two drives.

DPZ-/SPZ axis

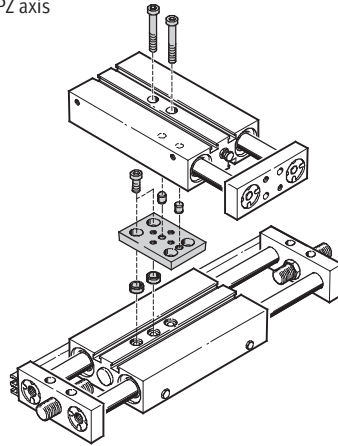

Adapter kits

→ www.festo.com

Shock absorbers for slide operation

- From 30 ... 900 mm/s
- In slide operation, shock absorbers provide highly dynamic but gentle operating characteristics

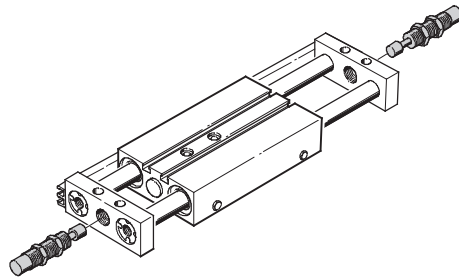

Slide operation SPZ...

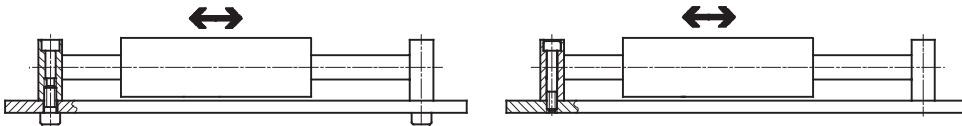

Slide units SPZ, twin piston

Overview and type codes

Function	Version	Piston Ø [mm]	Stroke [mm]	Position sensing A	Plain bearing guide GF	Recirculating ball bearing guide KF
Double-acting		10	10, 25, 40, 50	■	■	■
		16, 20, 25, 32	10, 25, 40, 50, 80, 100			

SPZ – 16 – 100 – P – A – KF

Type

Double-acting	
SPZ	Slide unit

Piston Ø [mm]

Stroke [mm]

Cushioning

P	Flexible cushioning rings/plates at both ends
---	---

Position sensing

A	For proximity sensor
---	----------------------

Guide

	Plain bearing guide
KF	Recirculating ball bearing guide

Slide units SPZ, twin piston

Peripherals overview

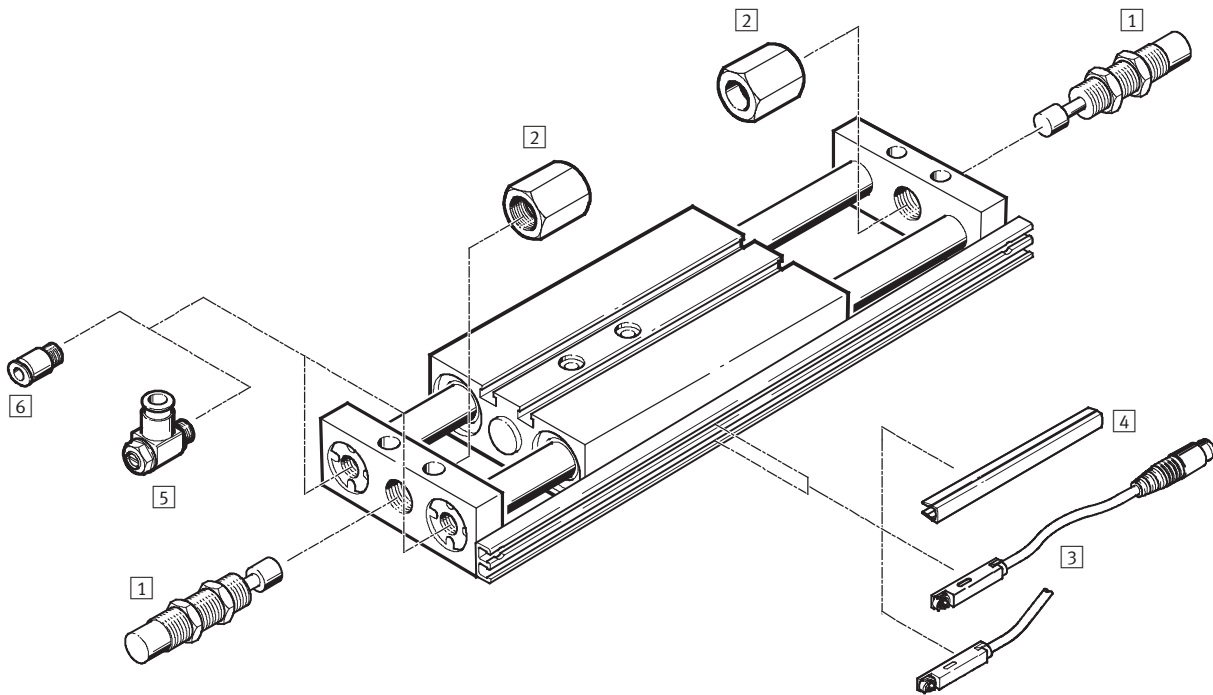

Accessories					
	Brief description	Piston Ø		→ Page/Internet	
		10, 16 mm	20, 25, 32 mm		
1	Shock absorber YSR-C	Hydraulic shock absorber with rapidly increasing cushioning characteristic	■	■	13
2	Stop limiters YSRA	Stroke limiter for shock absorber	■	■	13
3	Proximity sensor SME/SMT-8	Can be integrated in the cylinder profile barrel	Plain bearing guide	Plain bearing guide	14
4	Slot cover ABP-5-S	To protect the sensor cable and keep dirt out of the sensor slots	■	■	14
5	One-way flow control valve GRLA	To regulate speed	■	■	15
6	Push-in fitting QS	For connecting compressed air tubing with standard O.D.	■	■	quick star
-	Centring pin ZBS	2 pieces included in scope of delivery	■	-	15
-	Centring sleeve ZBH	2 pieces included in scope of delivery	-	■	15

Slide units SPZ, twin piston

Technical data

Function

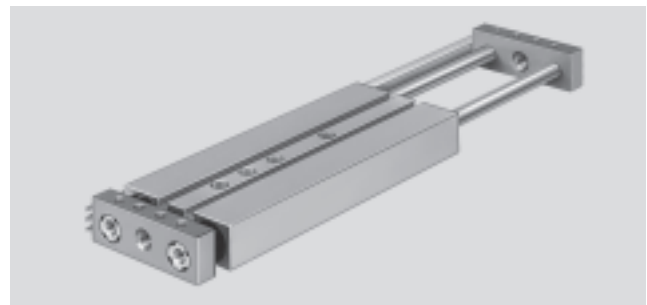
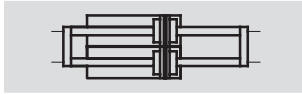

10 ... 32 mm



10 ... 100 mm



www.festo.com

General technical data					
Piston Ø	10	16	20	25	32
Pneumatic connection	M5	M5	M5	M5	G1/8
Operating medium	Compressed air in accordance with ISO 8573-1:2010 [7:4:4]				
Note on operating/pilot medium	Operation with lubricated medium possible (in which case lubricated operation will always be required)				
Operating pressure [bar]	2,5 ... 10	1 ... 10			
Constructional design	Slide				
	Parallel piston rods				
Cushioning	Flexible cushioning rings/plates at both ends				
Position sensing	For proximity sensing				
Type of mounting	Via through-holes				
	With female thread				
	With mounting plate				
Mounting position	Any				
Protection against torsion/guide	Parallel piston rods/with plain-bearing guide or ball bearing guide				

Ambient conditions		
Variant	Plain-bearing guide GF	Recirculating ball bearing guide KF
Ambient temperature ¹⁾ [°C]	-20 ... +80	
Corrosion resistance class CRC ²⁾	2	-
ATEX	Specified types → www.festo.com	

1) Note operating range of proximity sensors.

2) Corrosion resistance class 2 according to Festo standard 940 070

Components requiring moderate corrosion resistance. Externally visible parts with primarily decorative surface requirements which are in direct contact with a surrounding industrial atmosphere or media such as cooling or lubricating agents.

Forces [N]					
Piston Ø	10	16	20	25	32
Theoretical force at 6 bar, advancing	60	180	282	452	724
Theoretical force at 6 bar, retracting	60	180	282	452	724

Slide units SPZ, twin piston

Technical data

Permissible lateral force F_Q as a function of stroke l



Plain-bearing guide GF

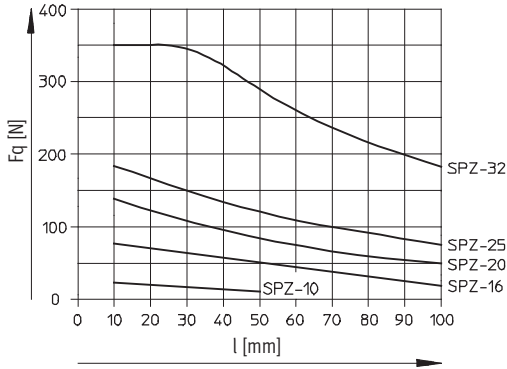

Recirculating ball bearing guide KF

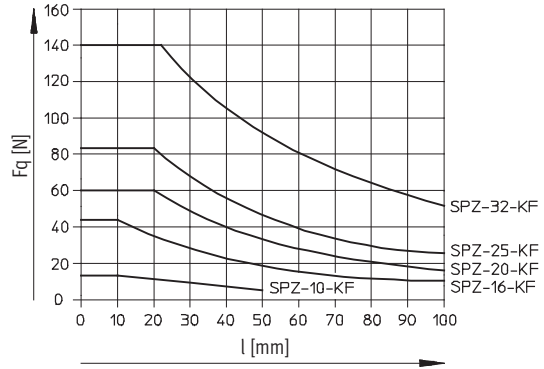

Permissible torque M_L as a function of stroke l

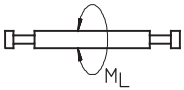

Plain-bearing guide GF

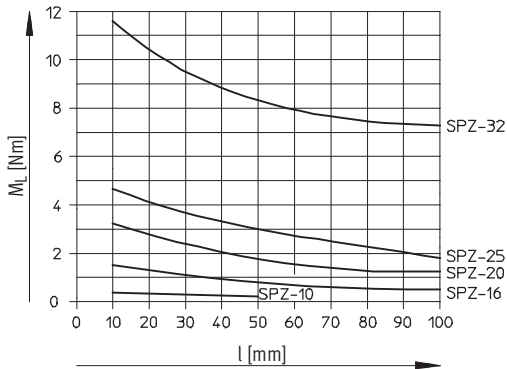

Recirculating ball bearing guide KF

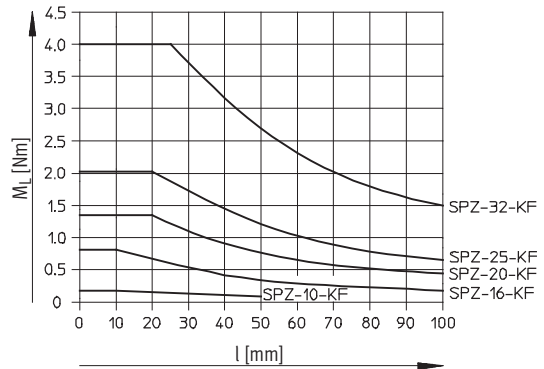

Slide units SPZ, twin piston

Technical data

Materials

Sectional view

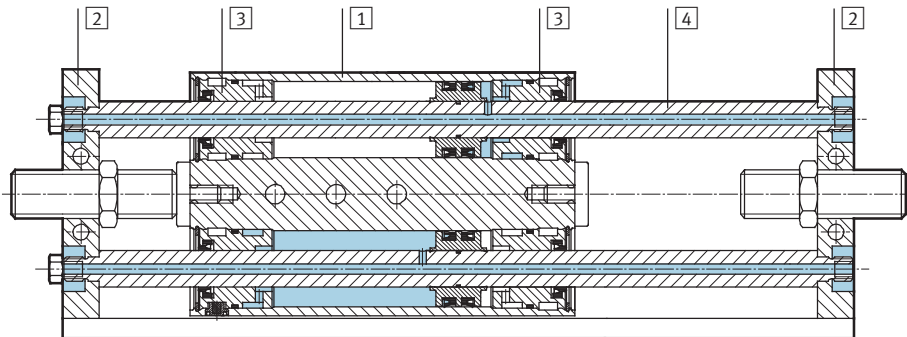

Slide unit

1	Housing		Wrought aluminium alloy
2	Yoke plate		Tool steel
3	Plug cap	GF	Brass
		KF	Wrought aluminium alloy
4	Piston rod	GF	High-alloy stainless steel
		KF	Tempered steel
-	Seals		Polyurethane, nitrile rubber

Slide units SPZ, twin piston

Technical data



Dimensions

Download CAD data → www.festo.com

Piston Ø 10, 16 mm, plain-bearing guide GF

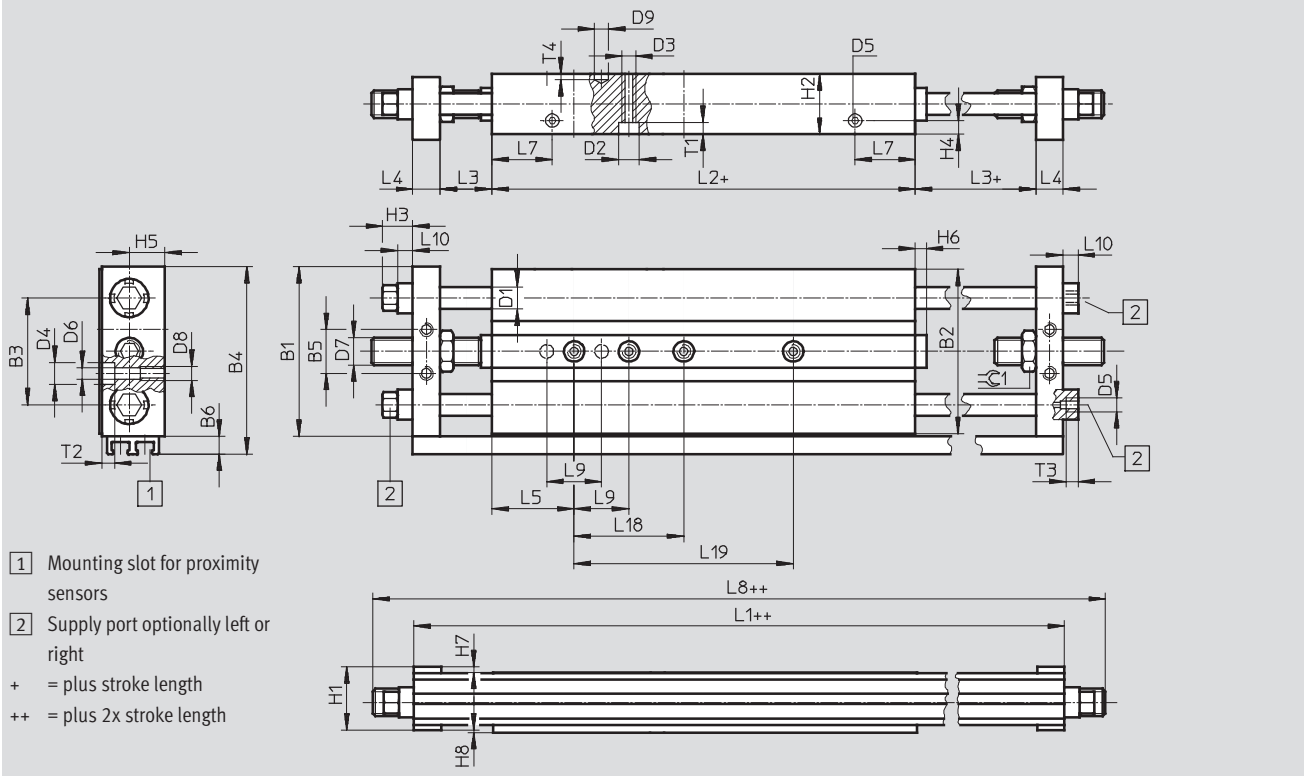

Ø	B1	B2	B3	B4	B5	B6	D1	D2	D3	D4	D5	D6	D7	D8	D9	H1	H2	H3
[mm]							Ø	Ø		Ø		Ø			Ø			
10	52	50	33	58.5	16	6.5	6	7.5	M5	8	M5	4.2	M10x1	M5	5	20	19	10
16	62	60	39	68.5	16	6.5	8	7.5	M5	8	M5	4.2	M10x1	M5	5	23	22	11

Ø	H4	H5	H6	H7	H8	L1	L2	L3	L4	L5	L7	L8	L9 ¹⁾	L10	T1	T2	T3	T4	≈C1
[mm]																			
10	5	11.5	4	2	1	129.6	71.6	19	10	30	23.4	159.6	20	4.5	4.4	3.4	5	2	13
16	5	13	4	2	1	132.6	74.6	19	10	30	22	162.6	20	5.5	4.4	4.6	4.5	2	13

Stroke	L18 ¹⁾	L19 ¹⁾
[mm]	±0.03	±0.03
10	-	-
25	-	-
40	40	-
50	40	-
80	40	80
100	40	80

1) Tolerance for centring hole ±0.03 mm
 Tolerance for thread ±0.2 mm

Slide units SPZ, twin piston

Technical data

Dimensions

Download CAD data → www.festo.com

Piston Ø 10, 16 mm, recirculating ball bearing guide KF

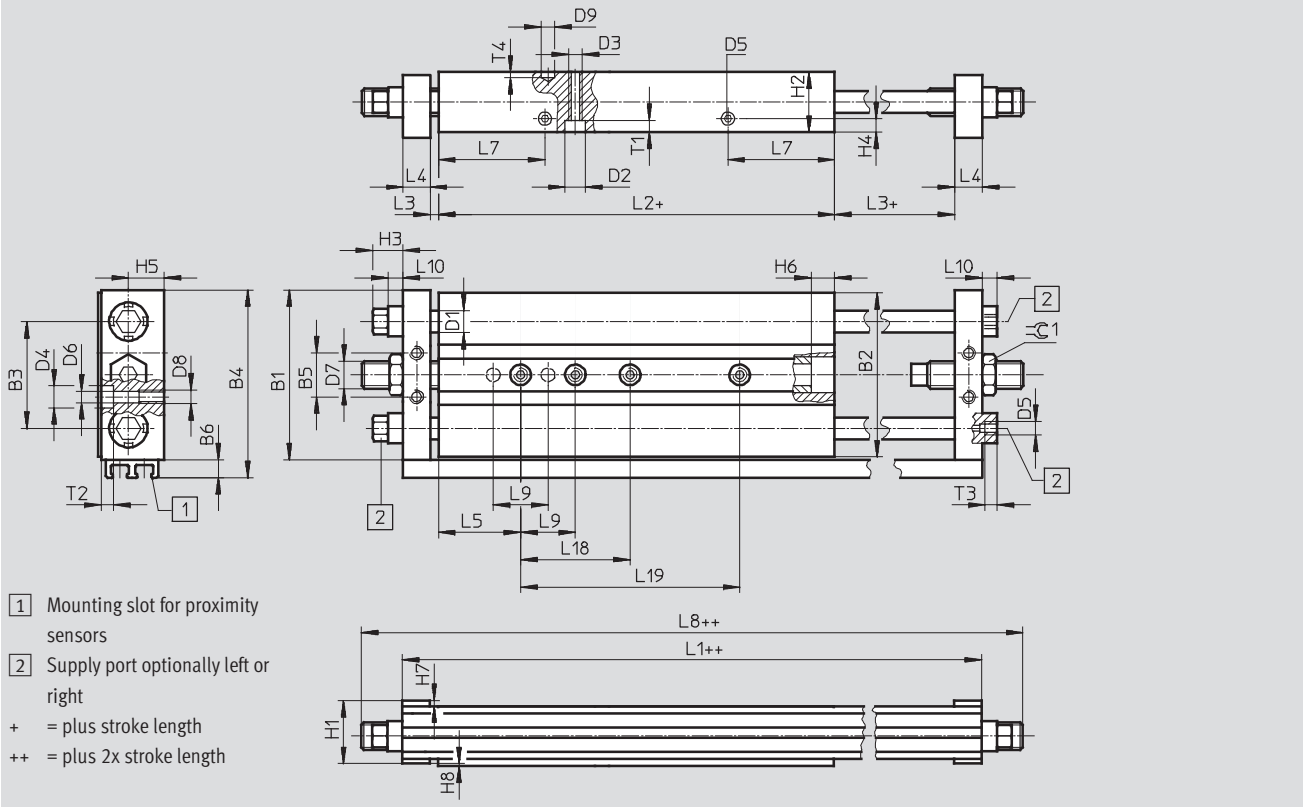

Ø	B1	B2	B3	B4	B5	B6	D1	D2	D3	D4	D5	D6	D7	D8	D9	H1	H2	H3	H4
[mm]							Ø	Ø		Ø		Ø			Ø				
10	52	50	33	58.5	16	6.5	6	7.5	M5	8	M5	4.2	M10x1	M5	5	20	19	10	5
16	62	60	39	68.5	16	6.5	8	7.5	M5	8	M5	4.2	M10x1	M5	5	23	22	11	5

Ø	H5	H6	H7	H8	L1	L2	L3	L4	L5	L7	L8	L9 ¹⁾	L10	T1	T2	T3	T4	≈C1
[mm]																		
10	11.5	7.5	2	1	129.6	107.6	1	10	30	40.7	159.6	20	4.5	4.4	3.4	5	2	13
16	13	7.5	2	1	132.6	106.6	3	10	30	38.9	158.6	20	5.5	4.4	4.6	4.5	2	13

Stroke	L18 ¹⁾	L19 ¹⁾
[mm]	±0.03	±0.03
10	-	-
25	-	-
40	40	-
50	40	-
80	40	80
100	40	80

1) Tolerance for centring hole ±0.03 mm
Tolerance for thread ±0.2 mm

Slide units SPZ, twin piston

Technical data



Dimensions

Download CAD data → www.festo.com

Piston Ø 20, 25, 32 mm, plain-bearing guide GF

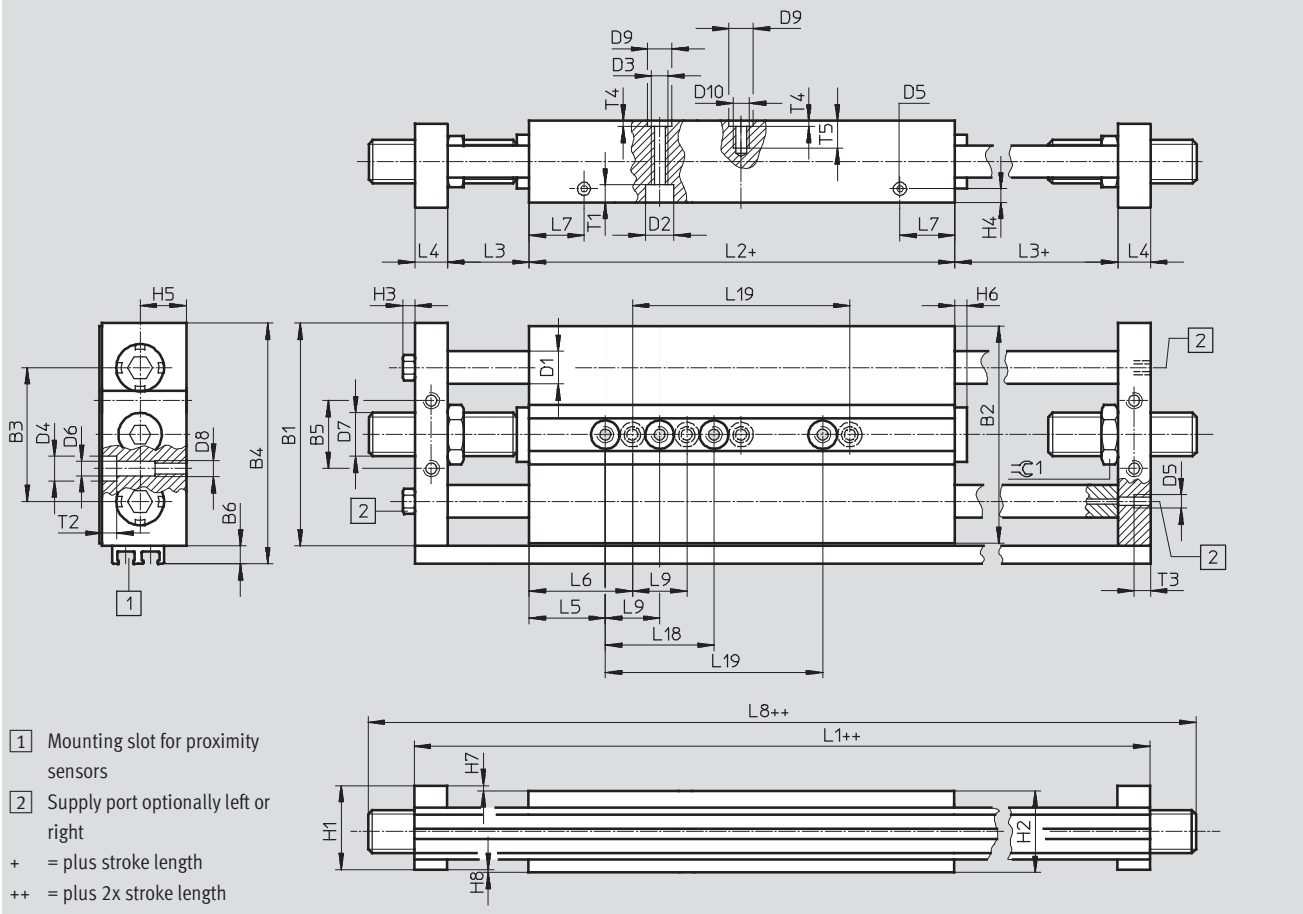

Ø	B1	B2	B3	B4	B5	B6	D1	D2	D3	D4	D5	D6	D7	D8	D9	D10	H1	H2	H3
[mm]							Ø	Ø	Ø	Ø		Ø			Ø H7				
20	74	72	45.6	80.5	23	6.5	10	9	M6	9.5	M5	5.2	M12x1	M6	9	M6	25	24	5
25	82	80	49.2	88.5	25	6.5	12	10.5	6.4	9.5	M5	5.2	M16x1	M6	9	M6	31	30	5
32	100	98	57	106.5	24	6.5	16	10.5	6.4	10.5	G1/8	6.2	M16x1	M8	9	M6	39	38	-

Ø	H4	H5	H6	H7	H8	L1	L2	L3	L4	L5	L6	L7	L8	L9 ¹⁾	T1	T2	T3	T4	T5	≲C1
[mm]																		+0.2		
20	5	14	4	2	1	146.6	76.6	23	12	30	-	22.8	178.6	20	5.4	5	6	2.1	10	15
25	5	17	4.5	2	1	160.6	76.6	30	12	28	38	20.2	194.6	20	6.4	5	6	2.1	10	19
32	7.5	21	4.5	2	1	170.1	80.1	30	15	35	45	25	204.1	20	6.4	6.5	10	2.1	10	19

Stroke	L18 ¹⁾	L19 ¹⁾
[mm]	±0.03	±0.03
10	-	-
25	-	-
40	40	-
50	40	-
80	40	80
100	40	80

1) Tolerance for centring hole ±0.03 mm
 Tolerance for thread ±0.2 mm

Slide units SPZ, twin piston

Technical data

Dimensions

Download CAD data → www.festo.com

Piston Ø 20, 25, 32 mm, recirculating ball bearing guide KF

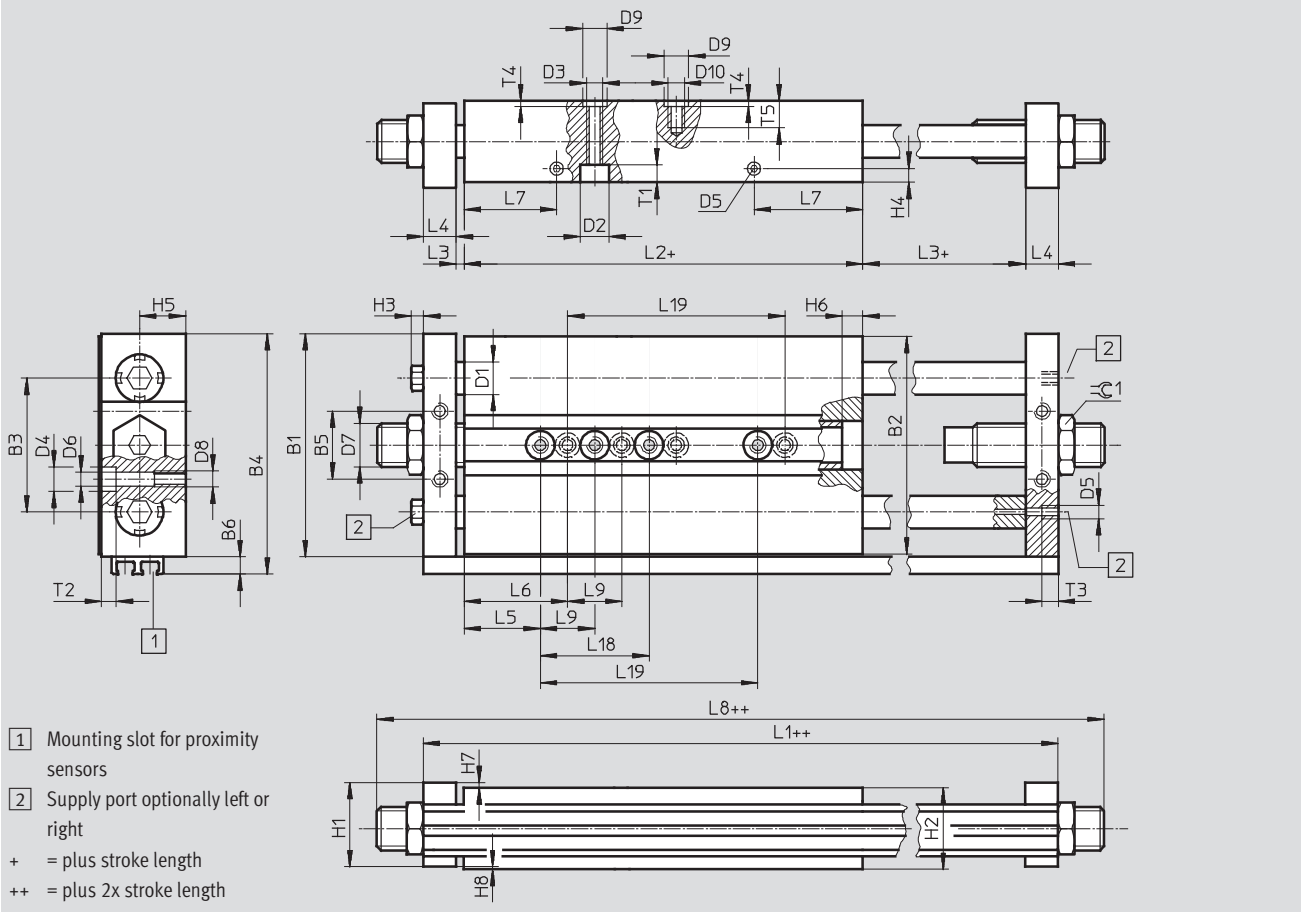

Ø	B1	B2	B3	B4	B5	B6	D1	D2	D3	D4	D5	D6	D7	D8	D9	D10	H1	H2	H3
[mm]							Ø	Ø	Ø	Ø		Ø			Ø H7				
20	74	72	45.6	80.5	23	6.5	10	9	M6	9.5	M5	5.2	M12x1	M6	9	M6	25	24	5
25	82	80	49.2	88.5	25	6.5	12	10.5	6.4	9.5	M5	5.2	M16x1	M6	9	M6	31	30	5
32	100	98	57	106.5	24	6.5	16	10.5	6.4	10.5	G1/8	6.2	M16x1	M8	9	M6	39	38	-

Ø	H4	H5	H6	H7	H8	L1	L2	L3	L4	L5	L6	L7	L8	L9 ¹⁾	T1	T2	T3	T4	T5	⊙C1
[mm]																				
20	5	14	6.5	2	1	146.6	120.6	1	12	30	-	43.4	184.6	20	5.4	5	6	2.1	10	15
25	5	17	7.5	2	1	160.6	130.6	3	12	28	38	40	202.6	20	6.4	5	6	2.1	10	19
32	7.5	21	7.5	2	1	170.1	134.1	3	15	35	45	44.9	206.1	20	6.4	6.5	10	2.1	10	19

Stroke	L18 ¹⁾	L19 ¹⁾
[mm]	±0.03	±0.03
10	-	-
25	-	-
40	40	-
50	40	-
80	40	80
100	40	80

1) Tolerance for centring hole ±0.03 mm
 Tolerance for thread ±0.2 mm

Slide units SPZ, twin piston

Technical data

Ordering data						
Type	Piston Ø [mm]	Stroke [mm]	Plain-bearing guide GF		Recirculating ball bearing guide KF	
			Part No.	Type ¹⁾	Part No.	Type ¹⁾
	10	10	32 714	SPZ-10-10-P-A	162 166	SPZ-10-10-P-A-KF
		25	32 715	SPZ-10-25-P-A	162 167	SPZ-10-25-P-A-KF
		40	32 716	SPZ-10-40-P-A	162 168	SPZ-10-40-P-A-KF
		50	32 717	SPZ-10-50-P-A	162 169	SPZ-10-50-P-A-KF
	16	10	32 719	SPZ-16-10-P-A	162 171	SPZ-16-10-P-A-KF
		25	32 720	SPZ-16-25-P-A	162 172	SPZ-16-25-P-A-KF
		40	32 721	SPZ-16-40-P-A	162 173	SPZ-16-40-P-A-KF
		50	32 722	SPZ-16-50-P-A	162 174	SPZ-16-50-P-A-KF
		80	32 723	SPZ-16-80-P-A	162 175	SPZ-16-80-P-A-KF
		100	32 724	SPZ-16-100-P-A	162 176	SPZ-16-100-P-A-KF
	20	10	32 726	SPZ-20-10-P-A	162 178	SPZ-20-10-P-A-KF
		25	32 727	SPZ-20-25-P-A	162 179	SPZ-20-25-P-A-KF
		40	32 728	SPZ-20-40-P-A	162 180	SPZ-20-40-P-A-KF
		50	32 729	SPZ-20-50-P-A	162 181	SPZ-20-50-P-A-KF
		80	32 730	SPZ-20-80-P-A	162 182	SPZ-20-80-P-A-KF
		100	32 731	SPZ-20-100-P-A	162 183	SPZ-20-100-P-A-KF
	25	10	32 733	SPZ-25-10-P-A	162 185	SPZ-25-10-P-A-KF
		25	32 734	SPZ-25-25-P-A	162 186	SPZ-25-25-P-A-KF
		40	32 735	SPZ-25-40-P-A	162 187	SPZ-25-40-P-A-KF
		50	32 736	SPZ-25-50-P-A	162 188	SPZ-25-50-P-A-KF
		80	32 737	SPZ-25-80-P-A	162 189	SPZ-25-80-P-A-KF
		100	32 738	SPZ-25-100-P-A	162 190	SPZ-25-100-P-A-KF
	32	10	159 721	SPZ-32-10-P-A	162 192	SPZ-32-10-P-A-KF
		25	159 722	SPZ-32-25-P-A	162 193	SPZ-32-25-P-A-KF
		40	159 723	SPZ-32-40-P-A	162 194	SPZ-32-40-P-A-KF
		50	159 724	SPZ-32-50-P-A	162 195	SPZ-32-50-P-A-KF
		80	159 725	SPZ-32-80-P-A	162 196	SPZ-32-80-P-A-KF
		100	159 726	SPZ-32-100-P-A	162 197	SPZ-32-100-P-A-KF

1) 2 centring pins or sleeves are included in the scope of delivery.

Slide units SPZ, twin piston

Accessories

Shock absorber YSR-C

Material:
 YSR-7-5-C, YSR-8-8-C: Nickel-plated brass
 YSR-12-12-C: Galvanised steel
 Free of copper, PTFE and silicone

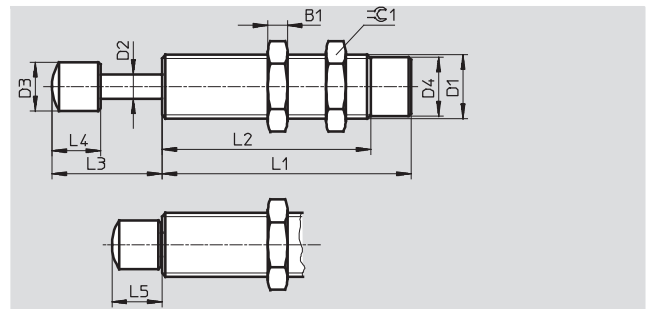

Dimensions and ordering data												Part No.	Type
For \varnothing	B1	D1	D2 \varnothing	D3 \varnothing	D4 \varnothing	L1 ± 0.1	L2 ± 0.3	L3 $+0.7/-0.35$	L4 ± 0.2	L5 $+0.55/-0.25$	\approx		
[mm]													
10, 16	3.5	M10x1	3	6 ± 0.1	8.6 ± 0.05	34	23	12.3	7	7.3	13	160 272	YSR-7-5-C
20	4	M12x1	4	8 ± 0.2	10.4 ± 0.1	46	33	16.3	8	8.3	15	34 571	YSR-8-8-C
25, 32	5	M16x1	6	12 ± 0.2	14.5 ± 0.1	64	51	24.5	12	12.5	19	34 572	YSR-12-12-C

Stop limiter YSRA

for use when shock absorbers are fitted
 (not in the case of recirculating ball bearing guide)

Material:
 Steel

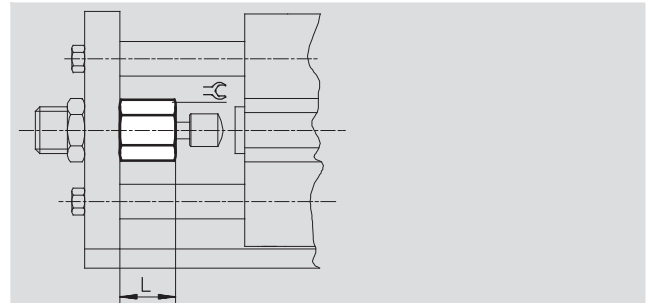



Dimensions and ordering data					
For \varnothing	L	\approx	For shock absorbers	Weight	Part No. Type
[mm]				[g]	
10, 16	15	13	YSR-7-5-C	12	150 932 YSRA-7-C
20	19	15	YSR-8-8-C	28	150 933 YSRA-8-C
25, 32	25.5	19	YSR-12-12-C	48	150 934 YSRA-12-C

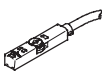
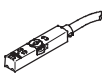

Slide units SPZ, twin piston

Accessories

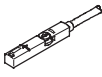
FESTO

Ordering data – Proximity sensors for T-slot, magneto-resistive						Technical data → Internet: smt	
	Type of mounting	Switch output	Electrical connection	Cable length [m]	Part No.	Type	
N/O contact							
	Insertable in the slot from above, flush with cylinder profile, short design	PNP	Cable, 3-wire	2.5	574335	SMT-8M-A-PS-24V-E-2,5-OE	
			Plug M8x1, 3-pin	0.3	574334	SMT-8M-A-PS-24V-E-0,3-M8D	
			Plug M12x1, 3-pin	0.3	574337	SMT-8M-A-PS-24V-E-0,3-M12	
		NPN	Cable, 3-wire	2.5	574338	SMT-8M-A-NS-24V-E-2,5-OE	
			Plug M8x1, 3-pin	0.3	574339	SMT-8M-A-NS-24V-E-0,3-M8D	
N/C contact							
	Insertable in the slot from above, flush with cylinder profile, short design	PNP	Cable, 3-wire	7.5	574340	SMT-8M-A-PO-24V-E-7,5-OE	

Ordering data – Proximity sensors for T-slot, magnetic reed						Technical data → Internet: sme		
	Type of mounting	Switch output	Electrical connection	Cable length [m]	Part No.	Type		
N/O contact								
	Insertable in the slot from above, flush with cylinder profile	Contacting	Cable, 3-wire	2.5	543 862	SME-8M-DS-24V-K-2,5-OE		
				5.0	543 863	SME-8M-DS-24V-K-5,0-OE		
			Plug M8x1, 3-pin	Cable, 2-wire	2.5	543 872	SME-8M-ZS-24V-K-2,5-OE	
				0.3	543 861	SME-8M-DS-24V-K-0,3-M8D		
	Insertable in the slot lengthwise, flush with the cylinder profile	Contacting	Cable, 3-wire	2.5	150 855	SME-8-K-LED-24		
			Plug M8x1, 3-pin	0.3	150 857	SME-8-S-LED-24		
N/C contact								
	Insertable in the slot lengthwise, flush with the cylinder profile	Contacting	Cable, 3-wire	7.5	160 251	SME-8-O-K-LED-24		

Ordering data – Connecting cables					Technical data → Internet: nebu	
	Electrical connection, left	Electrical connection, right	Cable length [m]	Part No.	Type	
	Straight socket, M8x1, 3-pin	Cable, open end, 3-wire	2.5	541 333	NEBU-M8G3-K-2.5-LE3	
			5	541 334	NEBU-M8G3-K-5-LE3	
	Straight socket, M12x1, 5-pin	Cable, open end, 3-wire	2.5	541 363	NEBU-M12G5-K-2.5-LE3	
			5	541 364	NEBU-M12G5-K-5-LE3	
	Angled socket, M8x1, 3-pin	Cable, open end, 3-wire	2.5	541 338	NEBU-M8W3-K-2.5-LE3	
			5	541 341	NEBU-M8W3-K-5-LE3	
	Angled socket, M12x1, 5-pin	Cable, open end, 3-wire	2.5	541 367	NEBU-M12W5-K-2.5-LE3	
			5	541 370	NEBU-M12W5-K-5-LE3	



Ordering data – Slot cover for T-slot					
	Mounting	Length	Part No.	Type	
	Insertable from above	2x 0.5 m	151 680	ABP-5-S	

Slide units SPZ, twin piston

Accessories



Ordering data – One-way flow control valves				Technical data → Internet: grla	
	Connection		Material	Part No.	Type
	Thread	For tubing O.D.			
	M5	3	Metal design	193 137	GRLA-M5-QS-3-D
		4		193 138	GRLA-M5-QS-4-D
		6		193 139	GRLA-M5-QS-6-D
	G $\frac{1}{8}$	3		193 142	GRLA- $\frac{1}{8}$ -QS-3-D
		4		193 143	GRLA- $\frac{1}{8}$ -QS-4-D
		6		193 144	GRLA- $\frac{1}{8}$ -QS-6-D
		8		193 145	GRLA- $\frac{1}{8}$ -QS-8-D

Ordering data – Accessories				Technical data → Internet: zbs	
	For dia. [mm]	Material	Part No.	Type	PE ¹⁾
Centring pin ZBS					
	10, 16	Stainless steel Free of copper, PTFE and silicone	150 928	ZBS-5	10
Centring sleeve ZBH					
	20, 25, 30	Stainless steel Free of copper, PTFE and silicone	150 927	ZBH-9	10

1) Packaging unit quantity

Product Range and Company Overview

A Complete Suite of Automation Services

Our experienced engineers provide complete support at every stage of your development process, including: conceptualization, analysis, engineering, design, assembly, documentation, validation, and production.



Custom Automation Components
Complete custom engineered solutions



Custom Control Cabinets
Comprehensive engineering support and on-site services



Complete Systems
Shipment, stocking and storage services

The Broadest Range of Automation Components

With a comprehensive line of more than 30,000 automation components, Festo is capable of solving the most complex automation requirements.



Electromechanical
Electromechanical actuators, motors, controllers & drives



Pneumatics
Pneumatic linear and rotary actuators, valves, and air supply



PLCs and I/O Devices
PLC's, operator interfaces, sensors and I/O devices

Supporting Advanced Automation... As No One Else Can!

Festo is a leading global manufacturer of pneumatic and electromechanical systems, components and controls for industrial automation, with more than 12,000 employees in 56 national headquarters serving more than 180 countries. For more than 80 years, Festo has continuously elevated the state of manufacturing with innovations and optimized motion control solutions that deliver higher performing, more profitable automated manufacturing and processing equipment. Our dedication to the advancement of automation extends beyond technology to the education and development of current and future automation and robotics designers with simulation tools, teaching programs, and on-site services.

Quality Assurance, ISO 9001 and ISO 14001 Certifications

Festo Corporation is committed to supply all Festo products and services that will meet or exceed our customers' requirements in product quality, delivery, customer service and satisfaction.

To meet this commitment, we strive to ensure a consistent, integrated, and systematic approach to management that will meet or exceed the requirements of the ISO 9001 standard for Quality Management and the ISO 14001 standard for Environmental Management.



© Copyright 2008, Festo Corporation. While every effort is made to ensure that all dimensions and specifications are correct, Festo cannot guarantee that publications are completely free of any error, in particular typing or printing errors. Accordingly, Festo cannot be held responsible for the same. For Liability and Warranty conditions, refer to our "Terms and Conditions of Sale", available from your local Festo office. All rights reserved. No part of this publication may be reproduced, distributed, or transmitted in any form or by any means, electronic, mechanical, photocopying or otherwise, without the prior written permission of Festo. All technical data subject to change according to technical update.



Printed on recycled paper at New Horizon Graphic, Inc., FSC certified as an environmentally friendly printing plant.

Festo North America

Festo Regional Contact Center

5300 Explorer Drive
Mississauga, Ontario L4W 5G4
Canada

USA Customers:

For ordering assistance,

Call: 1.800.99.FESTO (1.800.993.3786)

Fax: 1.800.96.FESTO (1.800.963.3786)

Email: customer.service@us.festo.com

For technical support,

Call: 1.866.GO.FESTO (1.866.463.3786)

Fax: 1.800.96.FESTO (1.800.963.3786)

Email: product.support@us.festo.com

Canadian Customers:

Call: 1.877.GO.FESTO (1.877.463.3786)

Fax: 1.877.FX.FESTO (1.877.393.3786)

Email: festo.canada@ca.festo.com

USA Headquarters

Festo Corporation
395 Moreland Road
P.O. Box 18023
Hauppauge, NY 11788, USA
www.festo.com/us

USA Sales Offices

Appleton

North 922 Tower View Drive, Suite N
Greenville, WI 54942, USA

Boston

120 Presidential Way, Suite 330
Woburn, MA 01801, USA

Chicago

1441 East Business Center Drive
Mt. Prospect, IL 60056, USA

Dallas

1825 Lakeway Drive, Suite 600
Lewisville, TX 75057, USA

Detroit – Automotive Engineering Center

2601 Cambridge Court, Suite 320
Auburn Hills, MI 48326, USA

New York

395 Moreland Road
Hauppauge, NY 11788, USA

Silicon Valley

4935 Southfront Road, Suite F
Livermore, CA 94550, USA

United States



USA Headquarters, East: Festo Corp., 395 Moreland Road, Hauppauge, NY 11788

Phone: 1.631.435.0800; Fax: 1.631.435.8026;

Email: info@festo-usa.com

www.festo.com/us

Canada



Headquarters: Festo Inc., 5300 Explorer Drive, Mississauga, Ontario L4W 5G4

Phone: 1.905.624.9000; Fax: 1.905.624.9001;

Email: festo.canada@ca.festo.com

www.festo.ca

Mexico



Headquarters: Festo Pneumatic, S.A., Av. Ceylán 3, Col. Tequesquahuac,
54020 Tlalneantla, Edo. de México

Phone: 011 52 [55] 53 21 66 00; Fax: 011 52 [55] 53 21 66 65;

Email: festo.mexico@mx.festo.com

www.festo.com/mx

Central USA

Festo Corporation
1441 East Business
Center Drive
Mt. Prospect, IL 60056, USA
Phone: 1.847.759.2600
Fax: 1.847.768.9480



Western USA

Festo Corporation
4935 Southfront Road,
Suite F
Livermore, CA 94550, USA
Phone: 1.925.371.1099
Fax: 1.925.245.1286



Festo Worldwide

Argentina Australia Austria Belarus Belgium Brazil Bulgaria Canada Chile China Colombia Croatia Czech Republic Denmark
Estonia Finland France Germany Great Britain Greece Hong Kong Hungary India Indonesia Iran Ireland Israel Italy Japan Latvia
Lithuania Malaysia Mexico Netherlands New Zealand Norway Peru Philippines Poland Romania Russia Serbia Singapore
Slovakia Slovenia South Africa South Korea Spain Sweden Switzerland Taiwan Thailand Turkey Ukraine United States Venezuela

www.festo.com