

Parallel grippers HGPT-B, heavy-duty



# Parallel grippers HGPT-B, heavy-duty

Key features

## Advantages compared with the parallel gripper HGPT

- Space-optimised:**  
 Choice of shorter housing without gripping force retention or longer housing with gripping force retention
- Increased gripping force/ high-force variant:**  
 Gripping force increased by 30% by means of oval piston. High-force variant also available: half the stroke, twice the force
- Reduced weight:**  
 Systematic use of lighter and higher performance materials
- 4 sensor slots:**  
 Proximity sensors no longer project past the bottom of the housing. Up to four positions can be sensed with the proximity sensors

## At a glance

### General information

Sturdy and precise kinematic system for maximum torque absorption and long service life. The force generated by the linear motion is translated into the gripper jaw movement via a wedge mechanism

with guided motion sequence. This also guarantees synchronous movement of the gripper jaws. The virtually backlash-free plain-bearing guide is realised using ground-in gripper jaws.

### Flexible range of applications

#### A wide range of uses:

- Can be used as either a double-acting or single-acting gripper
- Compression spring for supplementary or retaining gripping forces
- Suitable for external and internal gripping
- Centring either via centring pins or centring sleeves

## The technology in detail

### Gripper closed

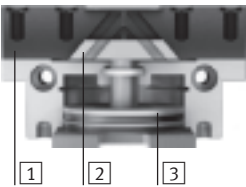

### Gripper open



- Gripper jaw
- Wedge with restricted guidance
- Piston with magnet

## Additional connections

### For sealing air

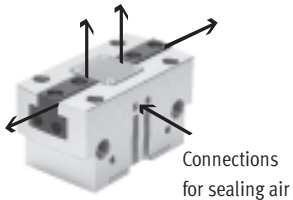

Compressed air flows past the gripper jaw when sealing air (max. 0.5 bar) is connected. This prevents, for example, dust particles from entering the gripper jaw guides.

### For lubrication



The connections can also be used for relubricating the guide.

## Position sensing/force control

### With position transmitter SMAT-8M



Infinite position sensing possible

- Analogue output 0 ... 10 V

### With proportional pressure regulator VPPM



Infinite adjustment of the gripping force possible

- Setpoint input
  - 0 ... 10 V
  - 4 ... 20 mA

### With proximity sensor SMT-8G/-10G



Multiple positions can be sensed:

- Open
- Closed
- Workpiece gripped

# Parallel grippers HGPT-B, heavy-duty

Key features

## Wide range of supply ports

Direct  
From the front

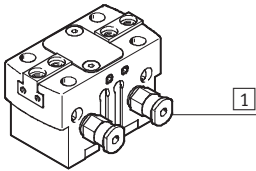

Via adapter plate  
From underneath

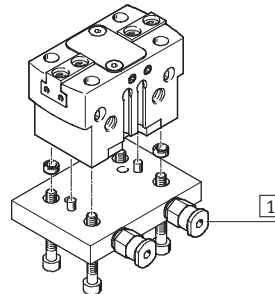

1 Supply ports

## Mounting options

Direct mounting  
From above

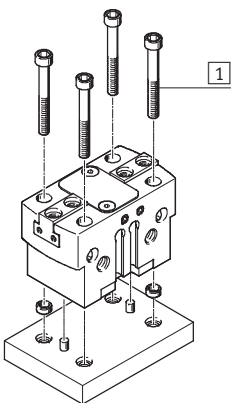

From underneath or from the side

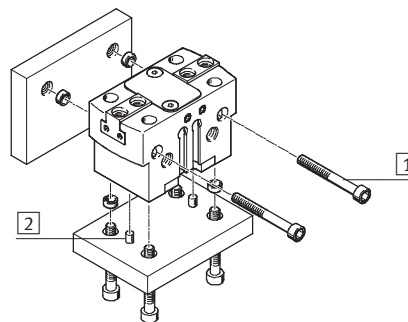

1 Mounting screws  
2 Centring pins, centring sleeves

**Note**  
These grippers are not suitable or are of limited suitability for the following application examples:

Not suitable for:

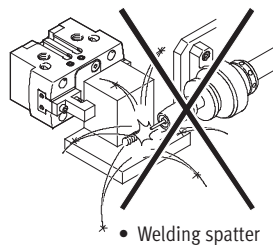

Of limited suitability for:

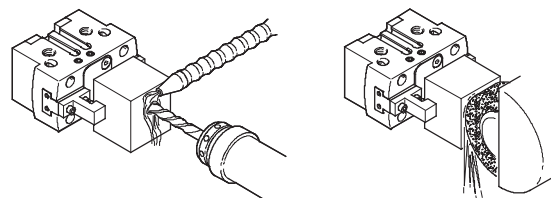

- Machining with sealing air possible
- Aggressive media only possible after consultation with Festo

# Parallel grippers HGPT-B, heavy-duty

Key features

FESTO

System product for handling and assembly technology

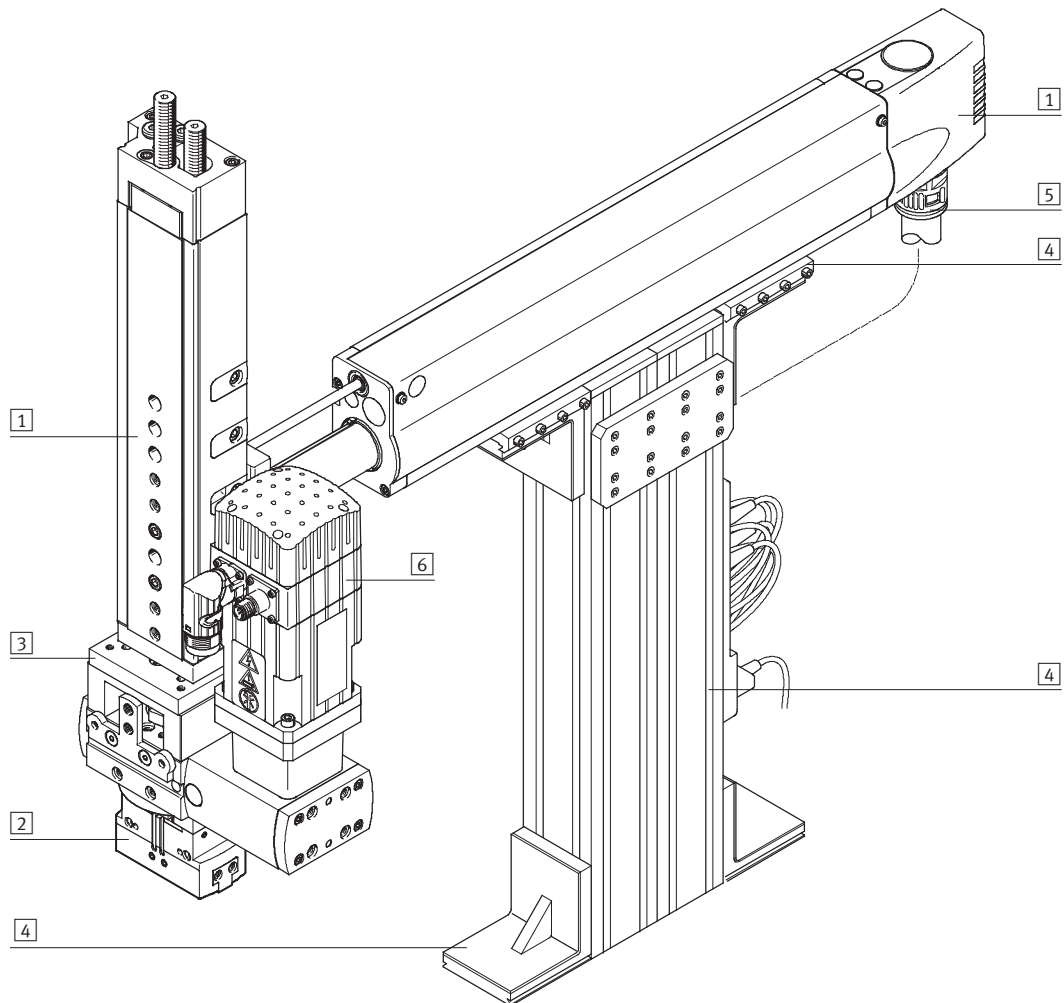

System components and accessories		
	Brief description	→ Page/Internet
1	Drives	Wide range of combinations possible within handling and assembly technology drive
2	Grippers	Wide range of variations possible within handling and assembly technology gripper
3	Adapters	For drive/drive and drive/gripper connections adapter kit
4	Basic components	Profiles and profile connections as well as profile/drive connections basic component
5	Installation components	For a clear, safe layout of electrical cables and tubing installation component
6	Motors	Servo and stepper motors, with or without gearing motor
-	Axes	Wide range of combinations possible within handling and assembly technology axis

# Parallel grippers HGPT-B, heavy-duty

Peripherals overview

FESTO

## Peripherals overview

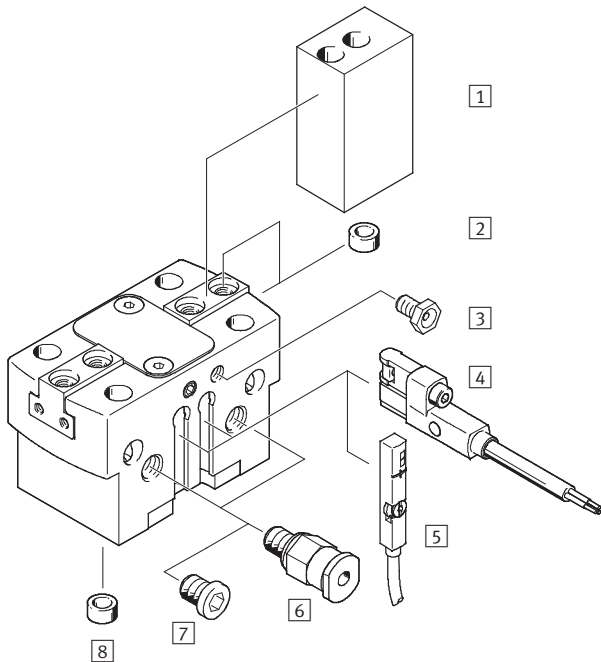

## System product for handling and assembly technology

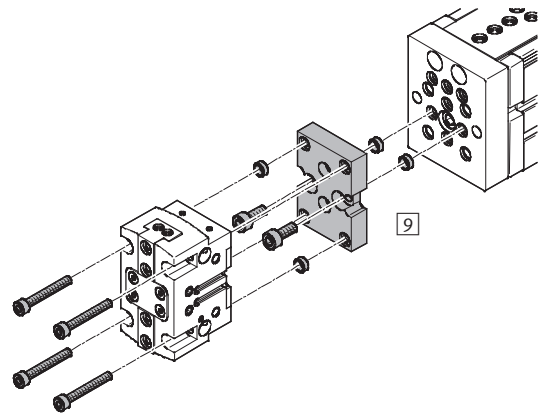

## Proportional pressure regulator VPPM

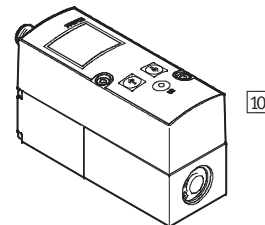

Accessories			
Type	Brief description		→ Page/Internet
1	Gripper jaw blank BUB-HGPT	Blank specially matched to the gripper jaws for custom production of gripper fingers	22
2	Centring sleeve ZBH	<ul style="list-style-type: none"> <li>For centring gripper jaw blanks/gripper fingers on the gripper jaws</li> <li>Centring sleeves are included in the scope of delivery of the gripper</li> </ul>	23
3	Lubrication nipple	Included in the scope of delivery of the gripper	–
4	Proximity sensor SMT-8G/-10G	<ul style="list-style-type: none"> <li>For sensing the piston position</li> <li>The proximity sensor is flush with the housing at the bottom</li> </ul>	23
5	Position transmitter SMAT-8M	<ul style="list-style-type: none"> <li>Continuously senses the position of the piston. It has an analogue output with an output signal that is proportional to the piston position.</li> <li>For size 40 ... 80</li> </ul>	24
6	Push-in fitting QS	For connecting compressed air tubing with standard O.D.	quick star
7	Blanking plug B	For sealing the supply ports when using the lower supply ports	23
8	Centring sleeve ZBH	For centring the gripper during mounting	23
9	Adapter kit HMSV, HAPG	Drive/gripper connections	19
10	Proportional pressure regulator VPPM	For infinite adjustment of the gripping force	vppm

# Parallel grippers HGPT-B, heavy-duty

Type codes

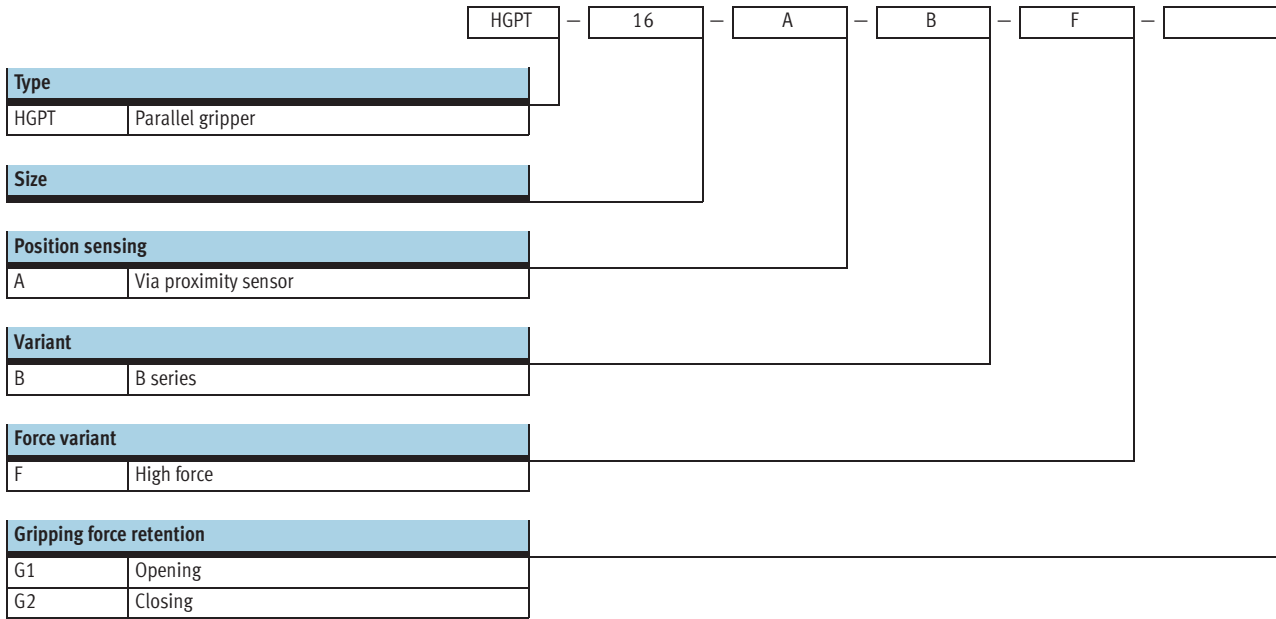

# Parallel grippers HGPT-B, heavy-duty

Technical data

Function  
Double-acting  
HGPT-...

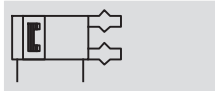

∅ - 16 ... 80 mm



3 ... 50 mm

Function – Variants  
Single-acting or  
with gripping force retention ...

... opening HGPT-...-G1



... closing HGPT-...-G2



General technical data									
Size	16	20	25	35	40	50	63	80	
Design	Wedge mechanism Guided motion sequence								
Mode of operation	Double-acting								
Gripper function	Parallel								
Number of gripper jaws	2								
Max. weight force per external gripper finger <sup>1)</sup> [N]	0.4	0.5	1.1	1.8	3.1	6.4	12.6	18.3	
Stroke per gripper jaw	HGPT-...-A [mm]	3	4	6	8	10	12	16	25
	HGPT-...-A-F [mm]	1.5	2	3	4	5	6	8	12.5
Pneumatic connection	M5	M5	M5	M5	M5	G $\frac{3}{8}$	G $\frac{3}{8}$	G $\frac{1}{4}$	
Pneumatic connection, sealing air	M3	M3	M5	M5	M5	M5	M5	M5	M5
Repetition accuracy <sup>2)</sup> [mm]	±0.01	±0.02		±0.025					
Max. interchangeability [mm]	0.2								
Max. operating frequency [Hz]	3				2				
Rotational symmetry [mm]	< ∅ 0.2								
Position sensing	Via proximity sensor, position transmitter								
Type of mounting	Via through-hole and locating pin/centring sleeve								
	Via female thread and locating pin/centring sleeve								
Mounting position	Any								

1) Valid for unthrottled operation

2) End-position drift under constant conditions of use with 100 consecutive strokes in the direction of movement of the gripper jaws

- † - Note: This product conforms to ISO 1179-1 and to ISO 228-1

Operating and environmental conditions		
Min. operating pressure	HGPT-...-A [bar]	3
	HGPT-...-A-G [bar]	4
Max. operating pressure [bar]	8	
Operating pressure, sealing air [bar]	0 ... 0.5	
Operating medium	Compressed air in accordance with ISO 8573-1:2010 [7:4:4]	
Note on operating/pilot medium	Operation with lubricated medium possible (in which case lubricated operation will always be required)	
Ambient temperature <sup>1)</sup> [°C]	+5 ... +60	
Corrosion resistance class CRC <sup>2)</sup>	2	

1) Note operating range of proximity sensors.

2) Corrosion resistance class 2 according to Festo standard 940 070

Components subject to moderate corrosion stress. Externally visible parts with primarily decorative surface requirements which are in direct contact with a normal industrial environment or media such as coolants or lubricating agents.

# Parallel grippers HGPT-B, heavy-duty

Technical data

Weight [g]								
Size	16	20	25	35	40	50	63	80
HGPT-...-A	85	135	266	490	821	1,400	2,712	4,745
HGPT-...-A-F	85	135	266	490	821	1,400	2,712	4,745
HGPT-...-A-G	100	155	353	567	1,075	1,832	3,562	6,287

## Materials

Sectional view

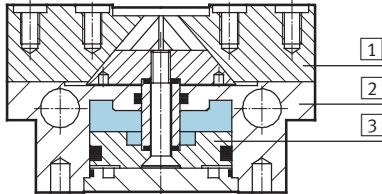

Parallel gripper	
1 Gripper jaw	Hardened steel
2 Housing	Hard anodised wrought aluminium alloy
3 Piston	Hard anodised aluminium
- Seals	Nitrile rubber
- Note on materials	Free of copper, PTFE and silicone
	RoHS-compliant

## Gripping force [N] at 6 bar

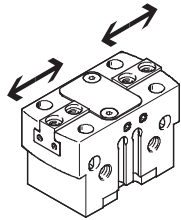

Size		16	20	25	35	40	50	63	80
Gripping force per gripper jaw									
HGPT-...-A	Opening	60	82	133	245	355	570	896	1,613
	Closing	53	77	124	229	331	535	851	1,551
HGPT-...-A-F	Opening	108	172	238	500	723	1,185	1,885	3,275
	Closing	96	161	221	467	674	1,113	1,791	3,150
Total gripping force									
HGPT-...-A	Opening	120	162	266	490	710	1,140	1,792	3,226
	Closing	106	154	248	458	662	1,070	1,702	3,102
HGPT-...-A-F	Opening	216	344	476	1,000	1,446	2,370	3,770	6,550
	Closing	192	322	442	934	1,328	2,226	3,522	6,300



# Parallel grippers HGPT-B, heavy-duty

Technical data

## Characteristic load values at the gripper jaws

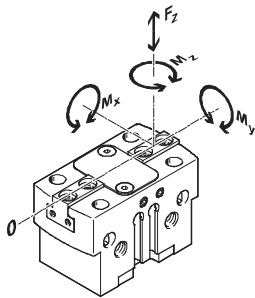

The indicated permissible forces and torques apply to a single gripper jaw. They include the lever arm, additional applied loads due to the workpiece or gripper fingers and acceleration

forces occurring during movement. The zero co-ordinate line (gripper jaw guide) must be taken into consideration for the calculation of torques.

Size		16	20	25	35	40	50	63	80
Max. permissible force $F_z$	[N]	200	700	1,200	1,800	2,500	3,200	5,000	7,000
Max. permissible torque $M_x$	[Nm]	10	15	50	80	100	120	160	180
Max. permissible torque $M_y$	[Nm]	12	15	45	60	90	120	180	220
Max. permissible torque $M_z$	[Nm]	6	8	35	50	75	100	140	170

## Mass moment of inertia [ $\text{kgm}^2 \times 10^{-4}$ ]

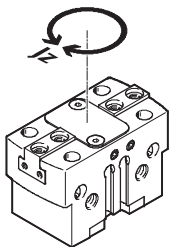

Mass moment of inertia of the parallel gripper in relation to the central axis, without external gripper fingers, without load.

Size		16	20	25	35	40	50	63	80
HGPT...-A		0.141	0.344	0.983	2.807	7.277	19.488	60.903	150.515
HGPT...-A-G		0.163	0.445	1.479	3.974	10.990	29.423	93.034	238.336

## Gripper jaw backlash

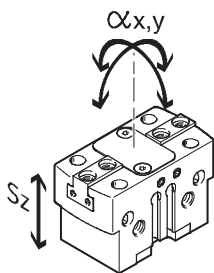

With grippers, backlash occurs between the gripper jaws and the housing due to the plain-bearing guide. The backlash values listed in the table have been calculated based on the traditional accumulative tolerance method.

Size		16	20	25	35	40	50	63	80
Max. gripper jaw backlash $S_z$	[mm]	0.02							
Max. gripper jaw angular backlash $\alpha_x, \alpha_y$	[°]	0.1							

# Parallel grippers HGPT-B, heavy-duty

Technical data



## Opening and closing times [ms] at 6 bar

Without external gripper fingers

With external gripper fingers

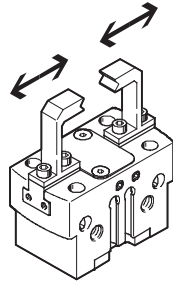
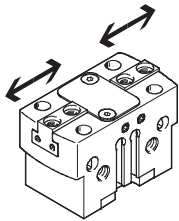

The indicated opening and closing times [ms] have been measured at room temperature at an operating pressure of 6 bar with horizontally mounted gripper without additional

gripper fingers. The grippers must be throttled for greater applied loads. Opening and closing times must then be adjusted accordingly.

Size		16	20	25	35	40	50	63	80	
Without external gripper fingers										
Standard	HGPT-...-A	Opening	9	22	26	36	56	80	150	214
		Closing	11	30	32	67	60	85	156	213
	HGPT-...-A-G1	Opening	13	13	24	37	67	70	146	182
		Closing	31	25	48	114	135	153	328	353
	HGPT-...-A-G2	Opening	22	35	40	69	122	151	294	379
		Closing	15	18	28	87	71	77	185	176
High force	HGPT-...-A-F	Opening	8	28	25	33	60	83	143	212
		Closing	10	31	32	70	64	82	152	211
	HGPT-...-A-F-G1	Opening	19	13	24	35	71	70	145	180
		Closing	30	25	45	115	143	143	315	340
	HGPT-...-A-F-G2	Opening	33	38	36	63	120	137	308	362
		Closing	17	14	28	72	72	80	154	178
With external gripper fingers (as a function of weight force)										
HGPT-...	0.5 N	10	-	-	-	-	-	-	-	
	1 N	15	30	-	-	-	-	-	-	
	2 N	21	42	35	-	-	-	-	-	
	3 N	-	52	42	42	-	-	-	-	
	4 N	-	-	49	49	63	-	-	-	
	5 N	-	-	-	55	71	-	-	-	
	6 N	-	-	-	-	78	-	-	-	
	8 N	-	-	-	-	90	90	-	-	
	10 N	-	-	-	-	-	95	-	-	
	12 N	-	-	-	-	-	100	-	-	
	15 N	-	-	-	-	-	-	164	-	
	18 N	-	-	-	-	-	-	179	-	
	20 N	-	-	-	-	-	-	189	223	
	22 N	-	-	-	-	-	-	-	234	
24 N	-	-	-	-	-	-	-	244		

# Parallel grippers HGPT-B, heavy-duty

Technical data

## Gripping force $F_H$ per gripper jaw as a function of operating pressure and lever arm $x$

The gripping forces as a function of operating pressure and lever arm can be determined from the following graphs.

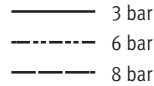
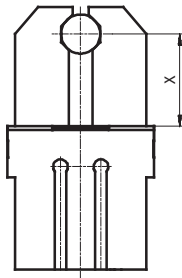

Note  
 Gripper selection sizing software  
 → [www.festo.com](http://www.festo.com)

## External gripping (closing)

Standard

HGPT-16-A

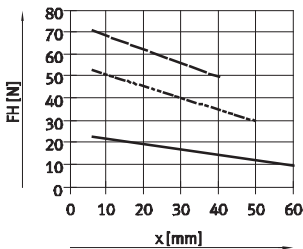

HGPT-20-A

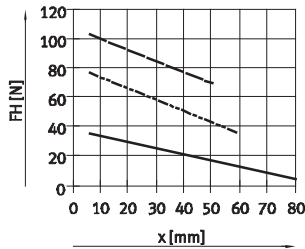

HGPT-25-A

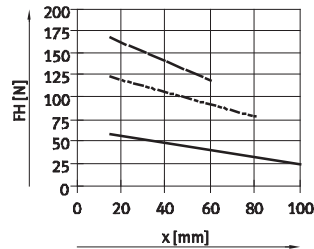

HGPT-35-A

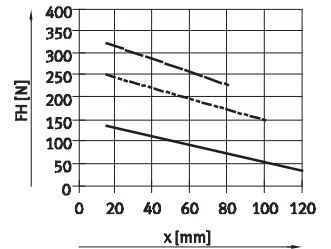

HGPT-40-A

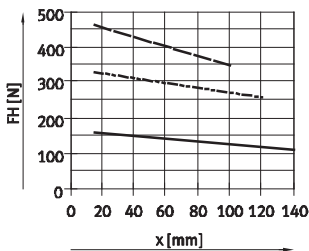

HGPT-50-A

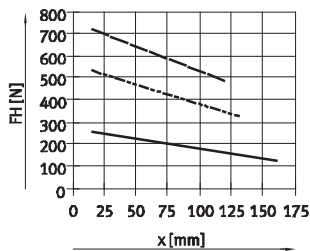

HGPT-63-A

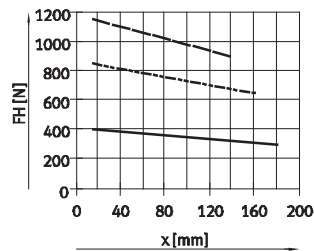

HGPT-80-A

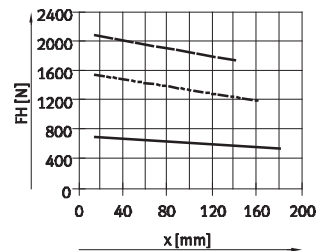

High force

HGPT-16-A-F

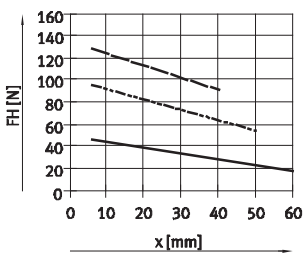

HGPT-20-A-F

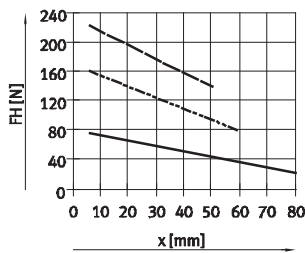

HGPT-25-A-F

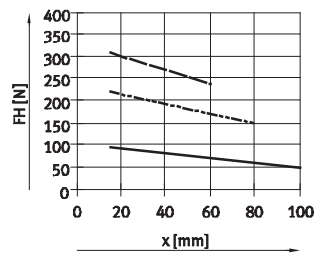

HGPT-35-A-F

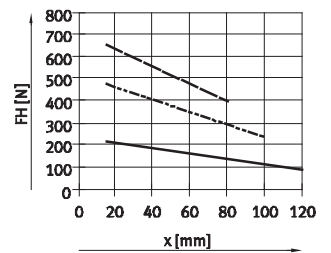

HGPT-40-A-F

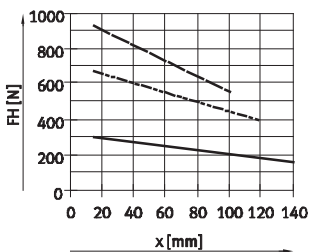

HGPT-50-A-F

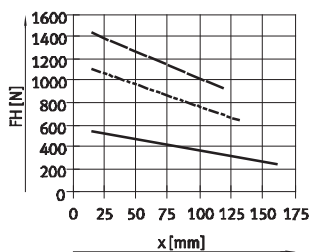

HGPT-63-A-F

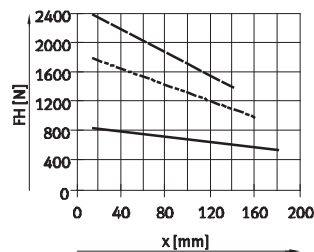

HGPT-80-A-F

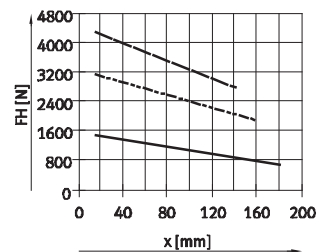

# Parallel grippers HGPT-B, heavy-duty

Technical data

## Gripping force $F_H$ per gripper jaw as a function of operating pressure and lever arm $x$

The gripping forces as a function of operating pressure and lever arm can be determined from the following graphs.

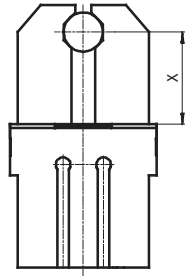

- 3 bar
- - - 6 bar
- · - 8 bar

Note  
Gripper selection  
sizing software  
→ [www.festo.com](http://www.festo.com)

## Internal gripping (opening)

Standard

HGPT-16-A

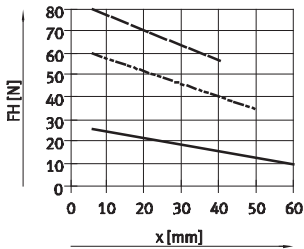

HGPT-20-A

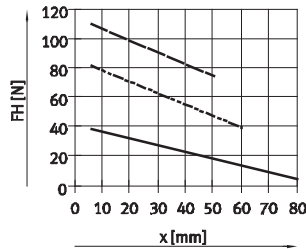

HGPT-25-A

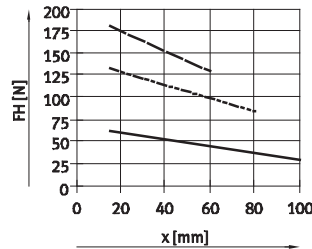

HGPT-35-A

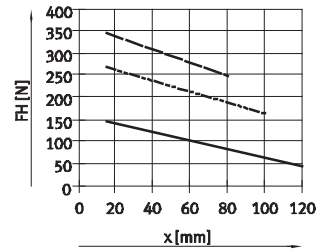

HGPT-40-A

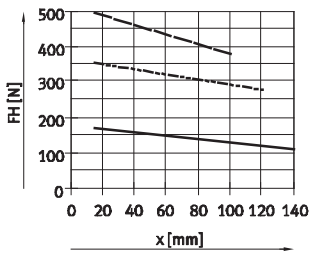

HGPT-50-A

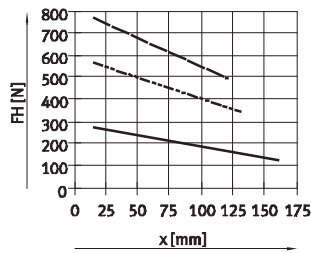

HGPT-63-A

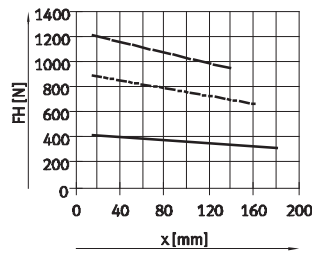

HGPT-80-A

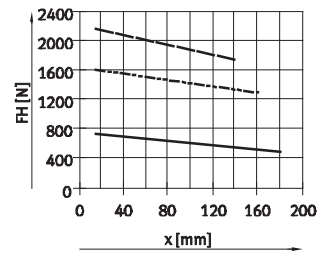

High force

HGPT-16-A-F

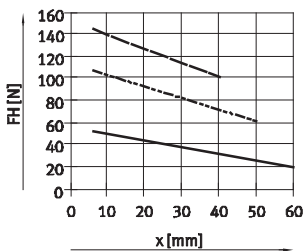

HGPT-20-A-F

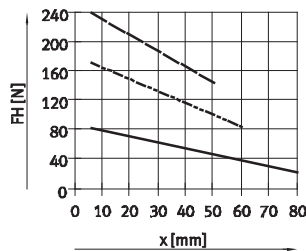

HGPT-25-A-F

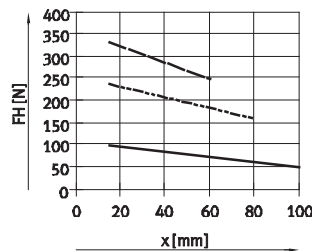

HGPT-35-A-F

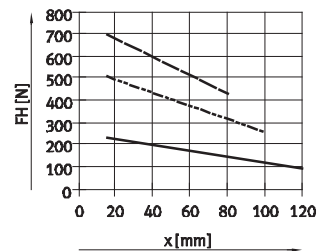

HGPT-40-A-F

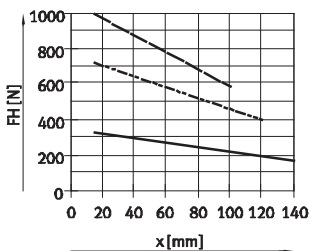

HGPT-50-A-F

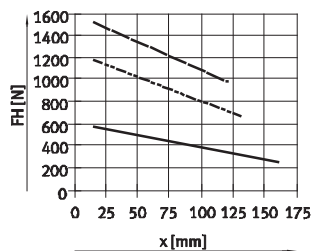

HGPT-63-A-F

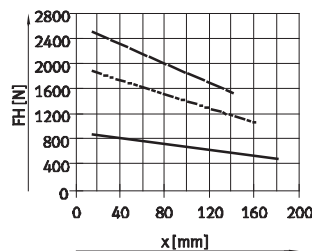

HGPT-80-A-F

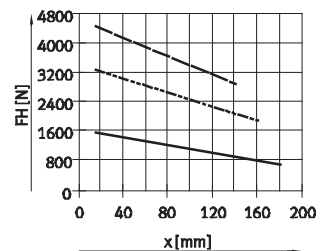

# Parallel grippers HGPT-B, heavy-duty

Technical data

## Gripping force $F_H$ per gripper jaw at 6 bar as a function of lever arm $x$ and eccentricity $a$ and $b$

The following formula must be used to calculate the lever arm  $x$  with eccentric gripping:

$$x = \sqrt{a^2 + b^2}$$

The gripping force  $F_H$  can then be read from the graphs (→ from 11) using the calculated value  $x$ .

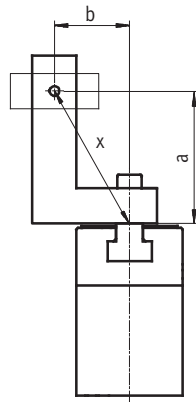

### Calculation example

Given:

Distance  $a = 45$  mm

Distance  $b = 40$  mm

To be calculated:

The gripping force at 6 bar, with an HGPT-25, used as an external gripper

Procedure:

Calculate the lever arm  $x$

$$x = \sqrt{45^2 + 40^2}$$

$x = 60$  mm

The graph (→ 11) gives a value of  $F_H = 89$  N for the gripping force.

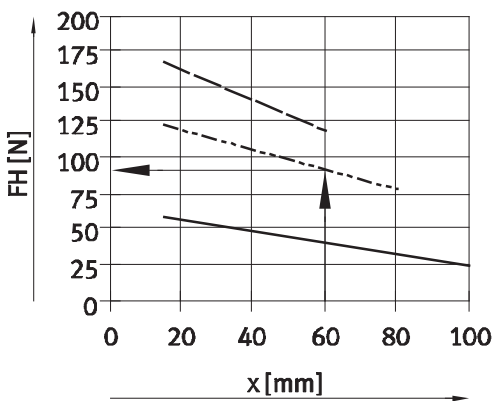

# Parallel grippers HGPT-B, heavy-duty

Technical data

## Spring force $F_f$ as a function of size, gripper jaw stroke $l$

Gripping force retention for HGPT-...-G...

The spring forces  $F_f$  as a function of gripper jaw stroke  $l$  can be determined from the following graph.

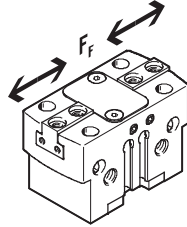

### Standard

HGPT-...-A-G

Size 16 ... 35

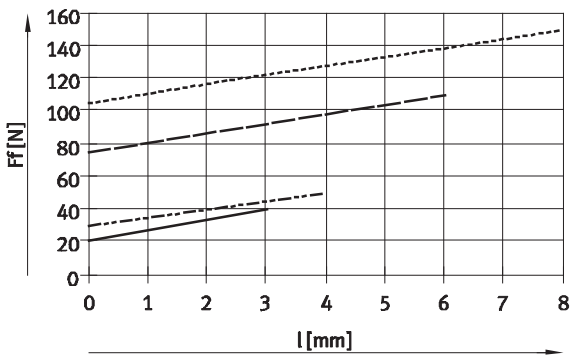

- HGPT-16-A-G
- - - HGPT-20-A-G
- · - HGPT-25-A-G
- · · HGPT-35-A-G

### High force

HGPT-...-A-F-G

Size 16 ... 35

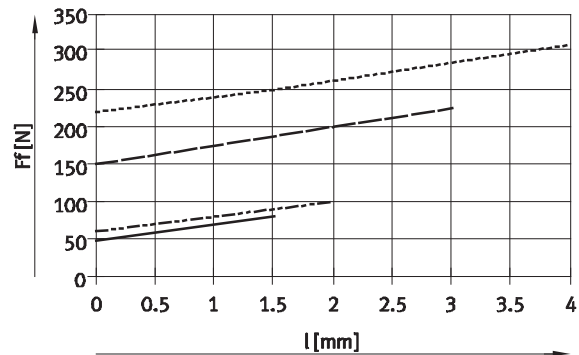

- HGPT-16-A-F-G
- - - HGPT-20-A-F-G
- · - HGPT-25-A-F-G
- · · HGPT-35-A-F-G

### Size 40 ... 80

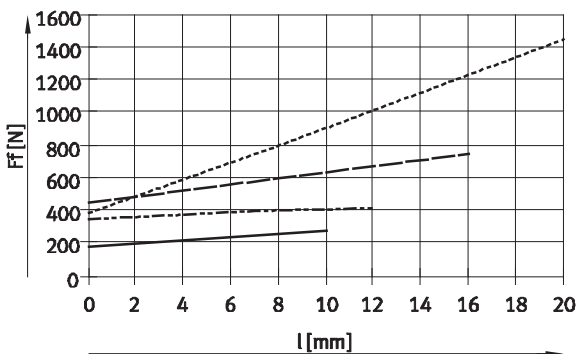

- HGPT-40-A-G
- - - HGPT-50-A-G
- · - HGPT-63-A-G
- · · HGPT-80-A-G

### Size 40 ... 80

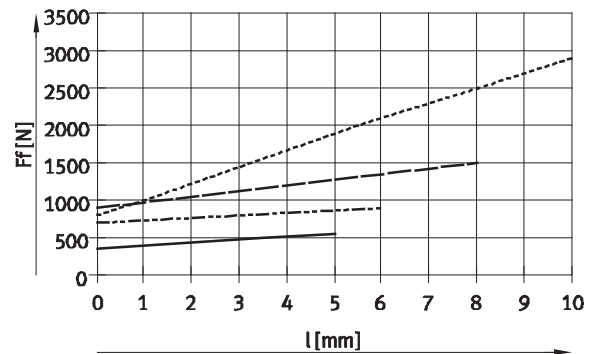

- HGPT-40-A-F-G
- - - HGPT-50-A-F-G
- · - HGPT-63-A-F-G
- · · HGPT-80-A-F-G

# Parallel grippers HGPT-B, heavy-duty

Technical data

FESTO

## Spring force $F_F$ as a function of size, gripper jaw stroke $l$ and lever arm $x$ per gripper finger

The lever arm  $x$  must be taken into consideration when determining the actual spring force  $F_{Ftotal}$ .

The formulae for calculating the spring force are provided in the table below.

### Standard – HGPT-...-A-G

Gripping force retention	Size	$F_{Ftotal} =$
G1	16	$-0.1 * x + 0.7 * F_F$
	20	$-0.05 * x + 0.9 * F_F$
	25	$-0.7 * x + 0.7 * F_F$
	35	$-0.65 * x + 0.7 * F_F$
	40	$-1.05 * x + 0.8 * F_F$
	50	$-0.75 * x + 0.8 * F_F$
	63	$-2 * x + 0.8 * F_F$
	80	$-1.4 * x + 0.6 * F_F$

Gripping force retention	Size	$F_{Ftotal} =$
G2	16	$-0.2 * x + 0.7 * F_F$
	20	$-0.65 * x + 0.9 * F_F$
	25	$-0.55 * x + 0.7 * F_F$
	35	$-0.05 * x + 0.7 * F_F$
	40	$-1.05 * x + 0.8 * F_F$
	50	$-1.4 * x + 0.8 * F_F$
	63	$-1.2 * x + 0.8 * F_F$
	80	$-0.6 * x + 0.6 * F_F$

### High force – HGPT-...-A-F-G

Gripping force retention	Size	$F_{Ftotal} =$
G1	16	$-0.6 * x + 0.6 * F_F$
	20	$-0.7 * x + 0.75 * F_F$
	25	$-0.85 * x + 0.9 * F_F$
	35	$-0.4 * x + 0.55 * F_F$
	40	$-1.9 * x + 0.75 * F_F$
	50	$-2.5 * x + 0.7 * F_F$
	63	$-5.5 * x + 0.7 * F_F$
	80	$-5.65 * x + 0.8 * F_F$

Gripping force retention	Size	$F_{Ftotal} =$
G2	16	$-0.4 * x + 0.6 * F_F$
	20	$-0.95 * x + 0.75 * F_F$
	25	$-0.5 * x + 0.9 * F_F$
	35	$-0.4 * x + 0.55 * F_F$
	40	$-2.3 * x + 0.75 * F_F$
	50	$-1 * x + 0.7 * F_F$
	63	$-1 * x + 0.7 * F_F$
	80	$-0.5 * x + 0.8 * F_F$

## Determination of the actual gripping forces $F_{Gr}$ for HGPT-...-G1 and HGPT-...-G2 as a function of the application

The parallel grippers with integrated spring type HGPT-...-G1 (opening gripping force retention) and HGPT-...-G2 (closing gripping force retention) can be used as:

- single-acting grippers

- grippers with supplementary gripping force and
- grippers with gripping force retention depending on requirements.

In order to calculate available gripping forces  $F_{Gr}$  (per gripper jaw), the gripping force ( $F_H$ ) and spring force ( $F_{Ftotal}$ ) must be combined accordingly.

### Application

Single-acting	Supplementary gripping force	Gripping force retention
<ul style="list-style-type: none"> <li>• Gripping with spring force: <math>F_{Gr} = F_{Ftotal}</math></li> <li>• Gripping with pressure force: <math>F_{Gr} = F_H - F_{Ftotal}</math></li> </ul>	<ul style="list-style-type: none"> <li>• Gripping with pressure and spring force: <math>F_{Gr} = F_H + F_{Ftotal}</math></li> </ul>	<ul style="list-style-type: none"> <li>• Gripping with spring force: <math>F_{Gr} = F_{Ftotal}</math></li> </ul>

# Parallel grippers HGPT-B, heavy-duty

Technical data

FESTO

## Dimensions

Download CAD data → [www.festo.com](http://www.festo.com)

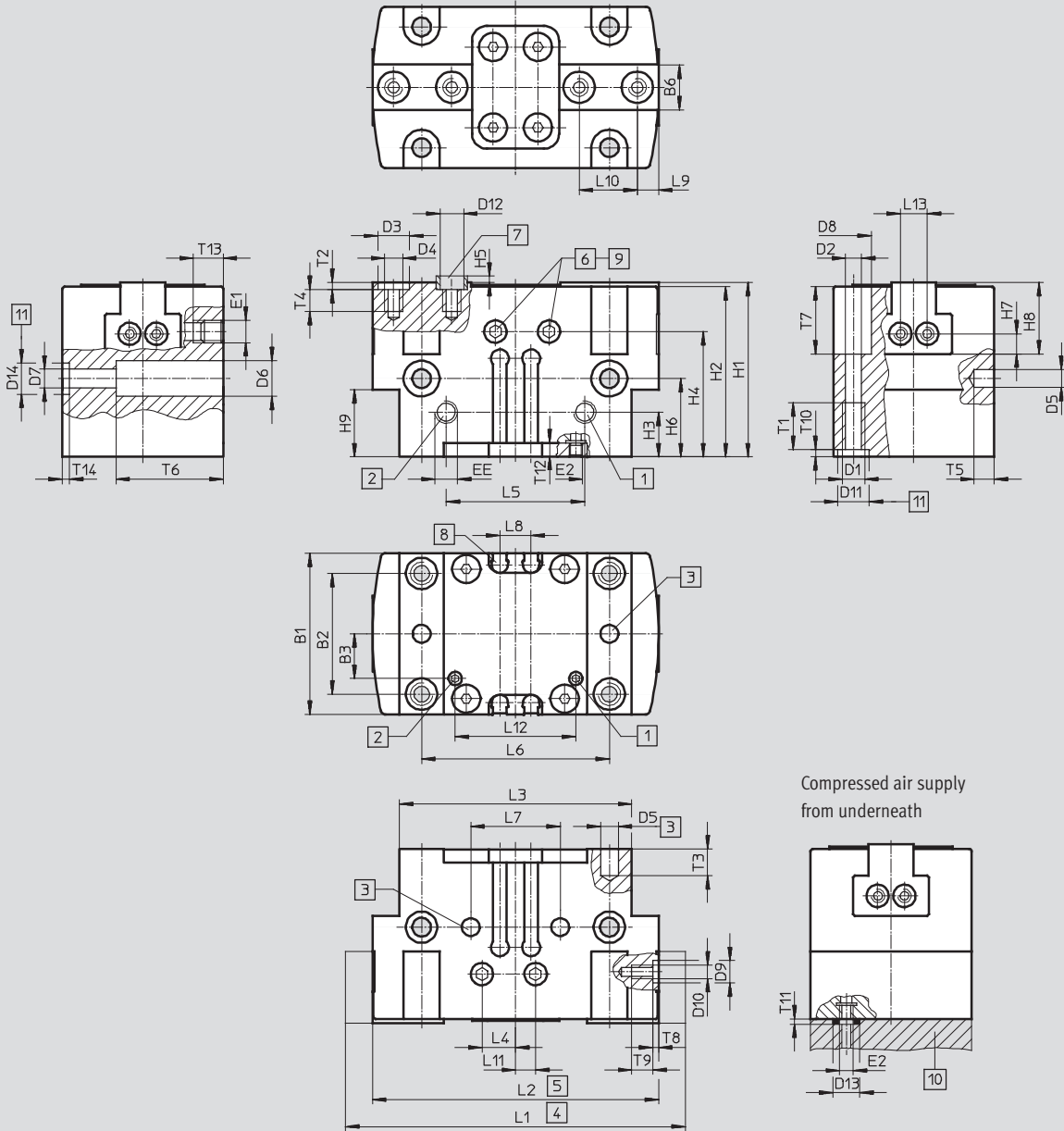

- 1 Supply port opening, either on the side or underneath (bottom port sealed on delivery)
- 2 Supply port closing, either on the side or underneath (bottom port sealed on delivery)

- 3 Hole for dowel pin (not included in the scope of delivery)
- 4 Gripper jaw open
- 5 Gripper jaw closed
- 6 Sealing air port (sealed on delivery)
- 7 Centring sleeves ZBH (4 included in the scope of delivery)

- 8 Slot for proximity sensor
- 9 Lubrication nipple (sealed on delivery)
- 10 O-ring for parallel gripper HGPT-16 ... 40:  $\varnothing$  3x1.5 HGPT-50 ... 80:  $\varnothing$  5x1.5
- 11 Hole for centring sleeve ZBH



# Parallel grippers HGPT-B, heavy-duty

Technical data

Size [mm]	B1 ±0.05	B2 <sup>1)</sup>	B3 ±0.1	B6 -0.05 -0.1	D1	D2 ∅	D3 ∅ H8/h7	D4	D5 ∅ H8	D6 ∅ ±0.1	D7 ∅	D8 ∅ +0.3	D9 ∅ H8	D10	D11 ∅ H8	D12 ∅
16	24	17	4	6	M3	2.6	5	M3	2	4.6	2.6	4.6	-	M2	5	3.2
20 <sup>2)</sup>	28	22	8.7	6.5	M4	3.3	5	M3	3	6	3.2	6	5	M3	5	3.2
25	36	27	11	10	M5	4.2	7	M4	4	8	4.2	8	5	M3	7	5.3
35	42	32	13	12	M5	4.2	9	M5	4	9.2	5.3	8	7	M5	7	6.4
40	50	38	17	14	M6	5.1	9	M6	5	11	6.4	9	7	M5	9	6.4
50	60	45	20	15.5	M8	6.8	9	M6	6	13.5	8.4	11	7	M5	12	6.4
63	72	56	24.5	20	M8	6.8	12	M10	6	13.5	8.4	11	7	M5	12	10.3
80	100	70	39.5	22	M10	8.5	15	M12	8	16.5	10.2	13.5	9	M6	12	12.4

Size [mm]	D13 ∅	D14 ∅ H8/h7	EE	E1	E2	H1		H2		H3		H4		H5 -0.3	H6 <sup>1)</sup>	
						±0.05	-G ±0.05	±0.05	-G ±0.05	±0.1	-G ±0.1		-G			-G
16	6	-	M5	M3	M3	29	37	28	36	12	12	23.7	31.7	1.2	17.5	25.5
20	6	-	M5	M3	M3	31	38	30	37	10	15	23	30	1.2	14.5	21.5
25	6	7	M5	M5	M3	39	57	38	56	10	20	28	46	1.4	17.5	35.5
35	6	7	M5	M5	M3	49	67	48	66	12	30	36	54	1.9	20	38
40	6	9	M5	M5	M3	55	81	54	80	15	36	41	67	1.9	25	51
50	8	12	G½	M5	M5	63	93	62	92	15	30	47	77	1.9	30	60
63	8	12	G½	M5	M5	77	117	76	116	18	26	56	96	2.4	28	68
80	8	12	G¼	M5	M5	91	133	90	132	22	33	65	107	2.9	34	76

Size [mm]	H7 <sup>1)</sup>	H8 -0.02	H9		L1		L2 ±0.5	L3 ±0.1	L4 ±0.5	L5 ±0.1	L6 <sup>1)</sup>	L7 <sup>1)</sup>	L8 +0.1	L9 <sup>1)</sup>	L10 <sup>1)</sup>	L11 ±0.5
			±0.1	-G ±0.1	±0.5	-F ±0.5										
16	2.25	8.5	15	23	50	47	44	36	5.5	20	29	20	6	3	8	1
20	3	12	15	22	64	60	56	44	2.5	24	35	24	6	3.25	12	2.5
25	4.5	16	15	33	76	70	64	52	3.5	31	42	20	7	4.75	13	3.5
35	5.5	19	20	38	96	88	80	64	5.5	40	52	40	7	5.5	16	5.5
40	5.5	22	24	50	120	110	100	80	5.5	49	66	50	10	6.5	20	5.5
50	7.5	25.5	26	56	149	137	125	100	5.5	63	82	60	10	8	24	5.5
63	9	32	32	72	192	176	160	125	5.5	74	100	76	10	9.5	32	5.5
80	11	39	34	77	230	205	180	154	5.5	82	130	100	10	12	40	5.5

Size [mm]	L12 ±0.1	L13 <sup>1)</sup>	T1 min.	T2 +0.1	T3 min.	T4 min.	T5 min.	T6	T7		T8 +0.1	T9	T10 +0.1	T11	T12 min.	T13 min.	T14 +0.1
									+0.2	-G +0.2							
16	22	6	5.5	1.3	4	5	4	15	14	22	-	3	1.3	1.2	3	5.5	-
20	22.6	6	6.5	1.3	5	5.5	4	19	11	11	1.3	6	1.3	1.2	3	5.5	-
25	29	6	8.5	1.6	6	6.5	4.5	24	15	15	1.3	6	1.6	1.2	3	6.7	1.6
35	39	13	8.5	2.1	6	8.5	4.5	16	19	19	1.6	9	1.6	1.2	3	6.5	1.6
40	47.4	13	10.5	2.1	6	10.5	6	33	20	20	1.6	9	2.1	1.2	4	6.5	2.1
50	61	13	12.5	2.1	8	10.5	6	43	23	23	1.6	9	2.6	1.2	4	6.5	2.6
63	75	13	12.5	2.6	8	15.5	7	55	35	35	1.6	9	2.6	1.2	5	6.5	2.6
80	82	20	15	3.1	10	20	10	70	44	44	2.1	10	2.6	1.2	5.5	5	2.6

1) Tolerance for centring hole ±0.02 mm

Tolerance for thread ±0.1 mm

2) Dowel pins [3] must be used when mounted from below.

- | - Note: This product conforms to ISO 1179-1 and to ISO 228-1

# Parallel grippers HGPT-B, heavy-duty



Technical data

Ordering data						
Size [mm]	Double-acting without compression spring		Single-acting or with gripping force retention			
	Part No.	Type	Opening		Closing	
	Part No.	Type	Part No.	Type	Part No.	Type
<b>Standard</b>						
16	560192	HGPT-16-A-B	560193	HGPT-16-A-B-G1	560194	HGPT-16-A-B-G2
20	560198	HGPT-20-A-B	560199	HGPT-20-A-B-G1	560200	HGPT-20-A-B-G2
25	560204	HGPT-25-A-B	560205	HGPT-25-A-B-G1	560206	HGPT-25-A-B-G2
35	560210	HGPT-35-A-B	560211	HGPT-35-A-B-G1	560212	HGPT-35-A-B-G2
40	560216	HGPT-40-A-B	560217	HGPT-40-A-B-G1	560218	HGPT-40-A-B-G2
50	560222	HGPT-50-A-B	560223	HGPT-50-A-B-G1	560224	HGPT-50-A-B-G2
63	560228	HGPT-63-A-B	560229	HGPT-63-A-B-G1	560230	HGPT-63-A-B-G2
80	560234	HGPT-80-A-B	560235	HGPT-80-A-B-G1	560236	HGPT-80-A-B-G2
<b>High force</b>						
16	560195	HGPT-16-A-B-F	560196	HGPT-16-A-B-F-G1	560197	HGPT-16-A-B-F-G2
20	560201	HGPT-20-A-B-F	560202	HGPT-20-A-B-F-G1	560203	HGPT-20-A-B-F-G2
25	560207	HGPT-25-A-B-F	560208	HGPT-25-A-B-F-G1	560209	HGPT-25-A-B-F-G2
35	560213	HGPT-35-A-B-F	560214	HGPT-35-A-B-F-G1	560215	HGPT-35-A-B-F-G2
40	560219	HGPT-40-A-B-F	560220	HGPT-40-A-B-F-G1	560221	HGPT-40-A-B-F-G2
50	560225	HGPT-50-A-B-F	560226	HGPT-50-A-B-F-G1	560227	HGPT-50-A-B-F-G2
63	560231	HGPT-63-A-B-F	560232	HGPT-63-A-B-F-G1	560233	HGPT-63-A-B-F-G2
80	560237	HGPT-80-A-B-F	560238	HGPT-80-A-B-F-G1	560239	HGPT-80-A-B-F-G2

# Parallel grippers HGPT-B, heavy-duty



Accessories

FESTO

**Adapter kit**  
DHAA, HAPG, HMSV

Material:  
Wrought aluminium alloy  
Free of copper and PTFE  
RoHS-compliant

 Note  
The kit includes the individual mounting interface as well as the necessary mounting material.

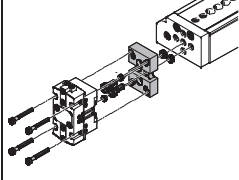
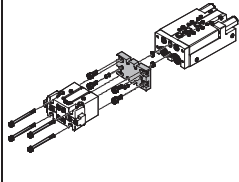
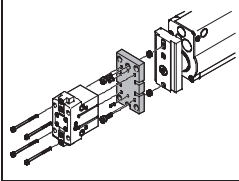
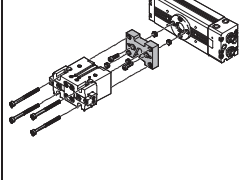
Permissible drive/gripper combinations with adapter kit					Download CAD data → <a href="http://www.festo.com">www.festo.com</a>	
Combination	Drive	Gripper	Mounting option		Adapter kit	
					CRC <sup>1)</sup>	Part No. Type
	DGSL	HGPT-B			DHAA, HAPG	
	8, 10	16, 20	■	■	2	564957 DHAA-G-G6-8-B8-16
	12, 16	16, 20	■	■		564954 DHAA-G-G6-16-B8-16
	12, 16	25	■	■		564952 DHAA-G-G6-16-B8-25
	20, 25	25, 35	■	■		537175 HAPG-79
	20, 25	40	■	■		564951 DHAA-G-G6-20-B8-40
	SLT	HGPT-B			DHAA, HAPG	
	6	16	■	–	2	537168 HAPG-74
	10	16, 20	■	–		564957 DHAA-G-G6-8-B8-16
	16	16, 20	■	–		564954 DHAA-G-G6-16-B8-16
	16	25	■	–		564952 DHAA-G-G6-16-B8-25
	20	25, 35	■	–		537175 HAPG-79
	25	35	■	–		564953 DHAA-G-H2-20-B8-35
	25	40	■	–		564951 DHAA-G-G6-20-B8-40
	HMP	HGPT-B			DHAA, HAPG	
	16	25	–	■	2	537178 HAPG-81
	20, 25	35	–	■		564953 DHAA-G-H2-20-B8-35
	20, 25	40	–	■		537182 HAPG-84
	25, 32	50	–	■		537185 HAPG-86
	32	63	–	■		537187 HAPG-87
	DRQD-...	HGPT-B			DHAA, HAPG	
	12, 16	16	■	■	2	564958 DHAA-G-Q5-12-B8-16
	12, 16	20	■	■		564955 DHAA-G-Q5-16-B8-20
	16, 20	25	■	■		537181 HAPG-SD2-25
	20, 25	35	■	■		537173 HAPG-SD2-23
	25, 32	40	■	■		537184 HAPG-SD2-26
	32, 40	50	■	■		564956 DHAA-G-Q5-32-B8-50
	40, 50	63	■	■		537188 HAPG-SD2-28
	DRQD-E422	HGPT-B			DHAA, HAPG	
	16	16, 20	■	■	2	564959 DHAA-G-Q5-16-B8-16
	16, 20	25	■	■		544642 HAPG-SD2-48
	20	35	■	■		544642 HAPG-SD2-48
	DRQD-E444	HGPT-B			HAPG	
32	50	■	■	2	544643 HAPG-SD2-49	

1) Corrosion resistance class 2 according to Festo standard 940 070  
Components subject to moderate corrosion stress. Externally visible parts with primarily decorative surface requirements which are in direct contact with a normal industrial environment or media such as coolants or lubricating agents.

# Parallel grippers HGPT-B, heavy-duty

Accessories



**Adapter kit**  
DHAA, HAPG, HMSV

Material:  
Wrought aluminium alloy  
Free of copper and PTFE  
RoHS-compliant

 Note  
The kit includes the individual mounting interface as well as the necessary mounting material.

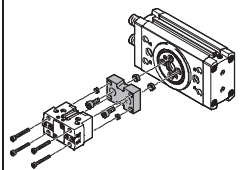
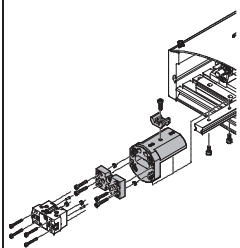
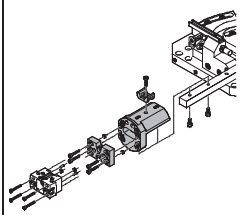
Permissible drive/gripper combinations with adapter kit						Download CAD data → <a href="http://www.festo.com">www.festo.com</a>	
Combination	Drive	Gripper	Mounting option		Adapter kit		
			Size	Size	CRC <sup>1)</sup>	Part No.	Type
<b>DRRD/HGPT-B</b>	DRRD	HGPT-B			DHAA		
	16	16	■	■	2	2091740	DHAA-G-Q11-16-B8-16
	16	20	■	■		2091577	DHAA-G-Q11-16-B8-20
	16	25	■	■		2090543	DHAA-G-Q11-16-B8-25
	20	25	■	■		2088114	DHAA-G-Q11-20-B8-25
	20	35	■	■		2087524	DHAA-G-Q11-20-B8-35
	25	35	■	■		1731604	DHAA-G-Q11-25-B8-35
	25	40	■	■		1731735	DHAA-G-Q11-25-B8-40
	32	40	■	■		2092070	DHAA-G-Q11-32-B8-40
	35	40	■	■		2114241	DHAA-G-Q11-35-B8-40
	32	50	■	■		2118750	DHAA-G-Q11-32-B8-50
	35, 40	50	■	■		2124990	DHAA-G-Q11-35/40-B8-50
	40	63	■	■		2125264	DHAA-G-Q11-40-B8-63
	<b>HSP/HGPT-B</b>	HSP	HGPT-B				DHAA, HAPG
	12	16	■	-	2	564957	DHAA-G-G6-8-B8-16
	16	16, 20	■	-		540881	HAPG-70-B
						564957	DHAA-G-G6-8-B8-16
	25	16, 20	■	-		540882	HAPG-71-B
				564957	DHAA-G-G6-8-B8-16		
				540883	HAPG-72-B		
<b>HSW/HGPT-B</b>	HSW	HGPT-B			DHAA, HAPG		
	12	16	■	-	2	564957	DHAA-G-G6-8-B8-16
	16	16, 20	■	-		540882	HAPG-71-B
						564957	DHAA-G-G6-8-B8-16
				540882	HAPG-71-B		

1) Corrosion resistance class 2 according to Festo standard 940 070  
Components subject to moderate corrosion stress. Externally visible parts with primarily decorative surface requirements which are in direct contact with a normal industrial environment or media such as coolants or lubricating agents.

# Parallel grippers HGPT-B, heavy-duty



Accessories



**Adapter kit**  
DHAA, HAPG, HMSV

Material:  
Wrought aluminium alloy  
Free of copper and PTFE  
RoHS-compliant

 Note  
The kit includes the individual mounting interface as well as the necessary mounting material.

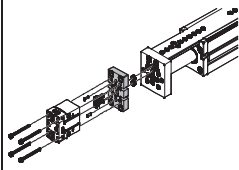
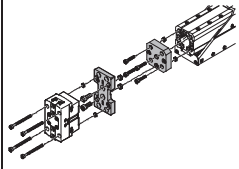
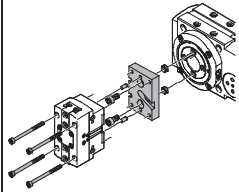
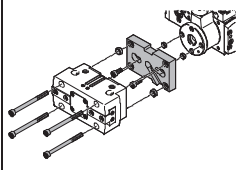
Permissible drive/gripper combinations with adapter kit						Download CAD data → <a href="http://www.festo.com">www.festo.com</a>	
Combination	Drive	Gripper	Mounting option		CRC <sup>1)</sup>	Part No.	Type
							
	EGSL	HGPT-B			2	564952	DHAA-G-G6-16-B8-25
	45, 55	25	■	■		564951	DHAA-G-G6-20-B8-40
	75	40	■	■		537175	HAPG-79
	75	25, 35	■	■			
	EGSA	HGPT-B			2	560017	HMSV-61
	50	16, 20	■	■		564954	DHAA-G-G6-16-B8-16
	50	25	■	■		560017	HMSV-61
	564952	DHAA-G-G6-16-B8-25					
60	25, 35	■	■	560018	HMSV-62		
537175	HAPG-79						
	ERMB	HGPT-B			2	537181	HAPG-SD2-25
	20	25	■	■		537173	HAPG-SD2-23
	20, 25	35	■	■		537184	HAPG-SD2-26
	25, 32	40	■	■		564956	DHAA-G-Q5-32-B8-50
32	50	■	■				
	EHMB	HGPT-B			2	537184	HAPG-SD2-26
	20	40	■	■		564956	DHAA-G-Q5-32-B8-50
	20, 25, 32	50	■	■		537188	HAPG-SD2-28
25, 32	63	■	■				

1) Corrosion resistance class 2 according to Festo standard 940 070  
Components subject to moderate corrosion stress. Externally visible parts with primarily decorative surface requirements which are in direct contact with a normal industrial environment or media such as coolants or lubricating agents.

# Parallel grippers HGPT-B, heavy-duty

Accessories

Gripper jaw blank BUB-HGPT  
(scope of delivery: 2 pieces)

Material:  
Aluminium

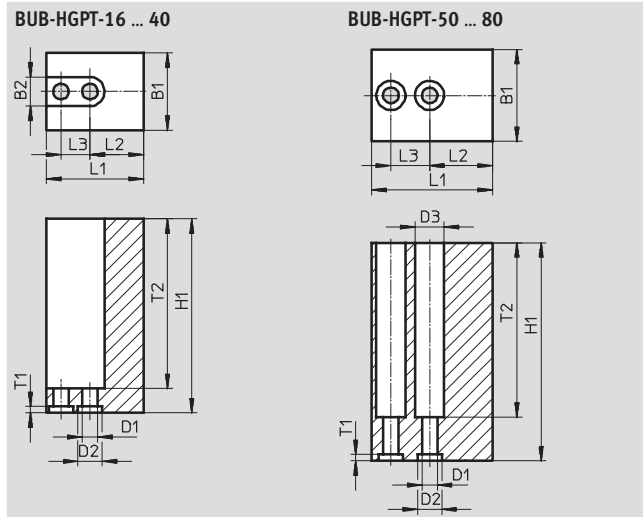

Dimensions and ordering data							
For size	B1	B2	D1	D2	D3	H1	L1
[mm]	±0.05	H13	∅ H13	∅ H8	∅ H13	±0.05	±0.05
16	16	6	3.2	5	-	40	21
20	19	6	3.2	5	-	45	27
25	24	8	4.3	7	-	60	31
35	28	10	5.3	9	-	70	39
40	34	11	6.4	9	-	75	49
50	40	-	6.4	9	11	100	61
63	50	-	10.3	12	17	120	79
80	58	-	12.4	15	20	140	88



For size	L2 <sup>1)</sup>	L3 <sup>1)</sup>	T1	T2	Weight per blank [g]	Part No.	Type
[mm]			+0.1				
16	10	8	1.3	35	29	560244	BUB-HGPT-16-B
20	11.75	12	1.3	36	53	560245	BUB-HGPT-20-B
25	13.25	13	1.6	51	98	560246	BUB-HGPT-25-B
35	17.5	16	2.1	61	161	560247	BUB-HGPT-35-B
40	22.5	20	2.1	66.5	280	560248	BUB-HGPT-40-B
50	29	24	2.1	91	622	560249	BUB-HGPT-50-B
63	37.5	32	2.6	110	1,213	560250	BUB-HGPT-63-B
80	36	40	3.1	125	1,738	560251	BUB-HGPT-80-B

1) Tolerance for centring hole ±0.02 mm  
Tolerance for thread ±0.1 mm

# Parallel grippers HGPT-B, heavy-duty

Accessories

**FESTO**

Ordering data				Technical data → <a href="http://www.festo.com">www.festo.com</a>		
	For size [mm]	Description	Weight [g]	Part No.	Type	PU <sup>1)</sup>
<b>Centring sleeve ZBH</b>				Technical data → <a href="http://Internet:zbh">Internet:zbh</a>		
	16, 20	For centring gripper jaw blanks/gripper fingers on the gripper jaws	1	<b>189652</b>	<b>ZBH-5</b>	10
	25		1	<b>186717</b>	<b>ZBH-7</b>	
	35, 40, 50		1	<b>150927</b>	<b>ZBH-9</b>	
	63		1	<b>189653</b>	<b>ZBH-12</b>	
	80		3	<b>191409</b>	<b>ZBH-15</b>	
	20, 25	For lateral centring of gripper fingers on the gripper jaws	1	<b>189652</b>	<b>ZBH-5</b>	
	35, 40, 50, 63		1	<b>186717</b>	<b>ZBH-7</b>	
	80		1	<b>150927</b>	<b>ZBH-9</b>	
	16, 20	For centring the gripper during mounting	1	<b>189652</b>	<b>ZBH-5</b>	
	25, 35		1	<b>186717</b>	<b>ZBH-7</b>	
	40		1	<b>150927</b>	<b>ZBH-9</b>	
	50, 63, 80		1	<b>189653</b>	<b>ZBH-12</b>	
	<b>Connecting sleeve ZBV</b>				Technical data → <a href="http://Internet:zbv">Internet:zbv</a>	
	–	For compensating different centring diameters	1	<b>571033</b>	<b>ZBV-6-5</b>	1
			1	<b>571034</b>	<b>ZBV-8-7</b>	
			1	<b>560253</b>	<b>ZBV-9-8</b>	
			2	<b>571035</b>	<b>ZBV-12-10</b>	
			2	<b>560255</b>	<b>ZBV-14-12</b>	
<b>Blanking plug B</b>				Technical data → <a href="http://Internet:blankingplug">Internet:blankingplug</a>		
	16, 20	For sealing the supply ports	1	<b>30979</b>	<b>B-M3-S9</b>	10
	25, 35, 40		1	<b>174308</b>	<b>B-M5-B</b>	
	50, 63		5	<b>3568</b>	<b>B-1/8</b>	
	80		15	<b>3569</b>	<b>B-1/4</b>	

1) Packaging unit

<b>Proximity sensors for size 16 ... 35</b>						
Ordering data – Proximity sensors for C-slot, magneto-resistive						Technical data → <a href="http://Internet:smt">Internet: smt</a>
	Type of mounting	Electrical connection, connection direction	Switching output	Cable length [m]	Part No.	Type
<b>N/O contact</b>						
	Insertable in the slot lengthwise	Cable, 3-wire, lateral	PNP	2.5	<b>547862</b>	<b>SMT-10G-PS-24V-E-2,5Q-OE</b>
		Plug M8x1, 3-pin, lateral		0.3	<b>547863</b>	<b>SMT-10G-PS-24V-E-0,3Q-M8D</b>

<b>Proximity sensors for size 40 ... 80</b>						
Ordering data – Proximity sensors for T-slot, magneto-resistive						Technical data → <a href="http://Internet:smt">Internet: smt</a>
	Type of mounting	Electrical connection, connection direction	Switching output	Cable length [m]	Part No.	Type
<b>N/O contact</b>						
	Insertable in the slot lengthwise	Cable, 3-wire, lateral	PNP	2.5	<b>547859</b>	<b>SMT-8G-PS-24V-E-2,5Q-OE</b>
		Plug M8x1, 3-pin, lateral		0.3	<b>547860</b>	<b>SMT-8G-PS-24V-E-0,3Q-M8D</b>

# Parallel grippers HGPT-B, heavy-duty

Accessories

FESTO

## Proximity sensors for size 40 ... 80

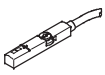
Ordering data – Position transmitters for T-slot					Technical data → Internet: smat	
	Type of mounting	Analogue output [V]	Electrical connection, connection direction	Cable length [m]	Part No.	Type
	Insertable in the slot from above	0 ... 10	Plug M8x1, 3-pin, in-line	0.3	553744	SMAT-8M-U-E-0,3-M8D

 Note

### Mode of operation:

The position transmitter continuously senses the position of the piston. It has an analogue output with an output signal that is proportional to the piston position.



### Measuring range:

Measurement is possible across the entire stroke with the sizes 40 and 50.  
A stroke of 13 mm (with the high-force variant 6.5 mm) can be measured with the sizes 63 and 80.

Two position transmitters are required for sensing longer strokes.

### Projection:

The position transmitter projects past the housing with the sizes 40 and 50.

Ordering data – Connecting cables				Technical data → Internet: nebu	
	Electrical connection, left	Electrical connection, right	Cable length [m]	Part No.	Type
	Straight socket, M8x1, 3-pin	Cable, open end, 3-wire	2.5	541333	NEBU-M8G3-K-2.5-LE3
			5	541334	NEBU-M8G3-K-5-LE3
	Angled socket, M8x1, 3-pin	Cable, open end, 3-wire	2.5	541338	NEBU-M8W3-K-2.5-LE3
			5	541341	NEBU-M8W3-K-5-LE3



# Product Range and Company Overview

## A Complete Suite of Automation Services

Our experienced engineers provide complete support at every stage of your development process, including: conceptualization, analysis, engineering, design, assembly, documentation, validation, and production.



**Custom Automation Components**  
Complete custom engineered solutions



**Custom Control Cabinets**  
Comprehensive engineering support and on-site services



**Complete Systems**  
Shipment, stocking and storage services

## The Broadest Range of Automation Components

With a comprehensive line of more than 30,000 automation components, Festo is capable of solving the most complex automation requirements.



**Electromechanical**  
Electromechanical actuators, motors, controllers & drives



**Pneumatics**  
Pneumatic linear and rotary actuators, valves, and air supply



**PLCs and I/O Devices**  
PLC's, operator interfaces, sensors and I/O devices

## Supporting Advanced Automation... As No One Else Can!

Festo is a leading global manufacturer of pneumatic and electromechanical systems, components and controls for industrial automation, with more than 12,000 employees in 56 national headquarters serving more than 180 countries. For more than 80 years, Festo has continuously elevated the state of manufacturing with innovations and optimized motion control solutions that deliver higher performing, more profitable automated manufacturing and processing equipment. Our dedication to the advancement of automation extends beyond technology to the education and development of current and future automation and robotics designers with simulation tools, teaching programs, and on-site services.

## Quality Assurance, ISO 9001 and ISO 14001 Certifications

Festo Corporation is committed to supply all Festo products and services that will meet or exceed our customers' requirements in product quality, delivery, customer service and satisfaction.

To meet this commitment, we strive to ensure a consistent, integrated, and systematic approach to management that will meet or exceed the requirements of the ISO 9001 standard for Quality Management and the ISO 14001 standard for Environmental Management.



© Copyright 2008, Festo Corporation. While every effort is made to ensure that all dimensions and specifications are correct, Festo cannot guarantee that publications are completely free of any error, in particular typing or printing errors. Accordingly, Festo cannot be held responsible for the same. For Liability and Warranty conditions, refer to our "Terms and Conditions of Sale", available from your local Festo office. All rights reserved. No part of this publication may be reproduced, distributed, or transmitted in any form or by any means, electronic, mechanical, photocopying or otherwise, without the prior written permission of Festo. All technical data subject to change according to technical update.



Printed on recycled paper at New Horizon Graphic, Inc., FSC certified as an environmentally friendly printing plant.

# Festo North America

## Festo Regional Contact Center

5300 Explorer Drive  
Mississauga, Ontario L4W 5G4  
Canada

### USA Customers:

For ordering assistance,

**Call:** 1.800.99.FESTO (1.800.993.3786)

**Fax:** 1.800.96.FESTO (1.800.963.3786)

**Email:** [customer.service@us.festo.com](mailto:customer.service@us.festo.com)

For technical support,

**Call:** 1.866.GO.FESTO (1.866.463.3786)

**Fax:** 1.800.96.FESTO (1.800.963.3786)

**Email:** [product.support@us.festo.com](mailto:product.support@us.festo.com)

### Canadian Customers:

**Call:** 1.877.GO.FESTO (1.877.463.3786)

**Fax:** 1.877.FX.FESTO (1.877.393.3786)

**Email:** [festo.canada@ca.festo.com](mailto:festo.canada@ca.festo.com)

---

## USA Headquarters

Festo Corporation  
395 Moreland Road  
P.O. Box 18023  
Hauppauge, NY 11788, USA  
[www.festo.com/us](http://www.festo.com/us)

---

## USA Sales Offices

### Appleton

North 922 Tower View Drive, Suite N  
Greenville, WI 54942, USA

### Boston

120 Presidential Way, Suite 330  
Woburn, MA 01801, USA

### Chicago

1441 East Business Center Drive  
Mt. Prospect, IL 60056, USA

### Dallas

1825 Lakeway Drive, Suite 600  
Lewisville, TX 75057, USA

### Detroit – Automotive Engineering Center

2601 Cambridge Court, Suite 320  
Auburn Hills, MI 48326, USA

### New York

395 Moreland Road  
Hauppauge, NY 11788, USA

### Silicon Valley

4935 Southfront Road, Suite F  
Livermore, CA 94550, USA

## United States



**USA Headquarters, East:** Festo Corp., 395 Moreland Road, Hauppauge, NY 11788

Phone: 1.631.435.0800; Fax: 1.631.435.8026;

Email: [info@festo-usa.com](mailto:info@festo-usa.com)

[www.festo.com/us](http://www.festo.com/us)

## Canada



**Headquarters:** Festo Inc., 5300 Explorer Drive, Mississauga, Ontario L4W 5G4

Phone: 1.905.624.9000; Fax: 1.905.624.9001;

Email: [festo.canada@ca.festo.com](mailto:festo.canada@ca.festo.com)

[www.festo.ca](http://www.festo.ca)

## Mexico



**Headquarters:** Festo Pneumatic, S.A., Av. Ceylán 3, Col. Tequesquahuac,  
54020 Tlalneantla, Edo. de México

Phone: 011 52 [55] 53 21 66 00; Fax: 011 52 [55] 53 21 66 65;

Email: [festo.mexico@mx.festo.com](mailto:festo.mexico@mx.festo.com)

[www.festo.com/mx](http://www.festo.com/mx)

---

## Central USA

Festo Corporation  
1441 East Business  
Center Drive  
Mt. Prospect, IL 60056, USA  
Phone: 1.847.759.2600  
Fax: 1.847.768.9480



## Western USA

Festo Corporation  
4935 Southfront Road,  
Suite F  
Livermore, CA 94550, USA  
Phone: 1.925.371.1099  
Fax: 1.925.245.1286



---

## Festo Worldwide

Argentina Australia Austria Belarus Belgium Brazil Bulgaria Canada Chile China Colombia Croatia Czech Republic Denmark  
Estonia Finland France Germany Great Britain Greece Hong Kong Hungary India Indonesia Iran Ireland Israel Italy Japan Latvia  
Lithuania Malaysia Mexico Netherlands New Zealand Norway Peru Philippines Poland Romania Russia Serbia Singapore  
Slovakia Slovenia South Africa South Korea Spain Sweden Switzerland Taiwan Thailand Turkey Ukraine United States Venezuela

[www.festo.com](http://www.festo.com)