

Electric cylinders ESBF, with spindle drive



Electric cylinders ESBF, with spindle drive

Key features

At a glance

The electric cylinder ESBF is a mechanical linear drive unit with piston rod. The driving component consists of an electrically actuated spindle that converts the rotary motion of the motor into a linear motion of the piston rod.

The electric cylinder is based on the ISO 15552 standard. The mechanical interfaces are largely compatible with the standard cylinder DSBF.

Options:

- High corrosion protection
- Protection class IP65
- Piston rod extension
- NSF-H1 lubricant
- Wide range of accessories

Complete system consisting of electric cylinder, motor and motor mounting kit

Electric cylinder

→ 4



Motor

→ 23



Note

A range of specially adapted complete solutions is available for the electric cylinder ESBF and the motors.

Motor mounting kit

→ 23

Axial kit

Parallel kit



A range of complete kits is available for both parallel and axial motor mounting.

Electric cylinders ESBF, with spindle drive

Features and type codes

Use in dusty environments with a protective bellows kit EADB

→ 27



The protective bellows kit is a leak-free system. To prevent unwanted media from being drawn in, the supply and exhaust air must be ducted via a pressure compensation hole in the connection part **1**.

The kit protects the piston rod, seal

and bearings against a wide variety of media, for example:

- Dust
- Chippings
- Oil
- Grease
- Fuel

Protection class IP65 (feature S1) allows it to be used in wet environments

→ 21

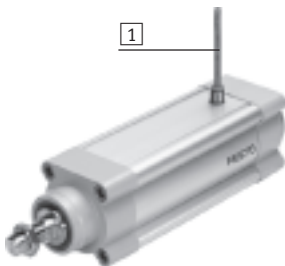

The electric cylinder to IP65 fulfils the specifications to IEC 60 529.

Air is exchanged between the interior of the cylinder and the environment via a pressure compensation hole **1** in the cylinder barrel. This prevents negative pressure or excess pressure in the interior of the cylinder.

It also prevents unwanted media being drawn in.

Type codes

		ESBF	–	BS	–	63	–	100	–	5P	–	F
Type												
ESBF	Electric cylinder											
Drive type												
BS	Ball screw spindle											
Size												
Stroke [mm]												
Spindle pitch [mm]												
Variant												
F	Female thread											
S1	Protection class IP65											
R3	High corrosion protection											
F1	Suitable for use in the food industry ¹⁾											
...E	Piston rod extension											

1) NSF-H1 lubricant for piston rod, screw spindle, etc.
 → declaration of conformity (www.festo.com/net/Support Portal)

Electric cylinders ESBF, with spindle drive

Peripherals overview

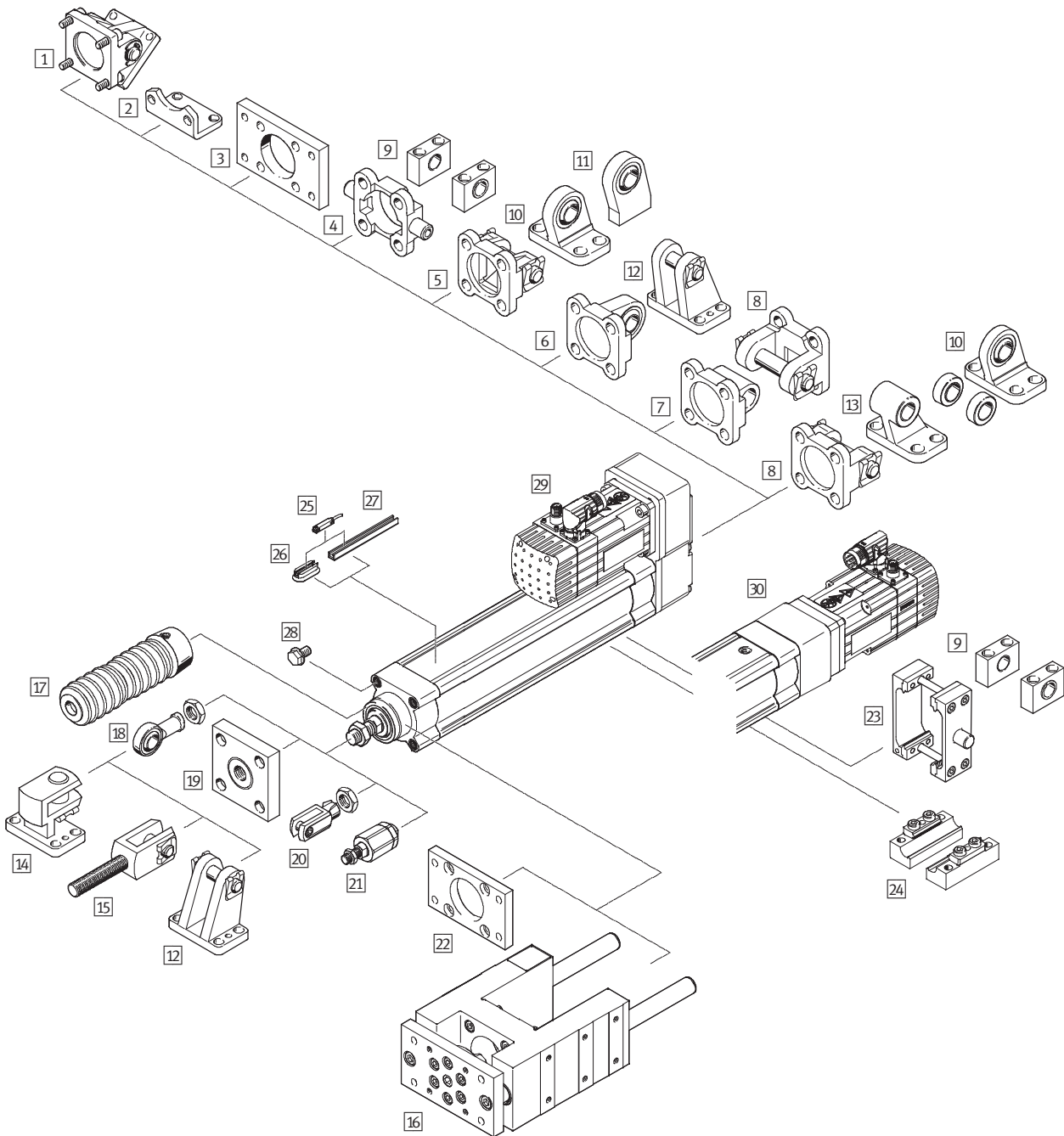

Mounting attachments and accessories			
	Brief description	Suitable for high forces ¹⁾	→ Page/Internet
1	Swivel flange DAMS	■	34
2	Foot mounting HNC/CRHNC	–	29
3	Flange mounting FNC/CRFNG	–	31
4	Trunnion flange ZNCF/CRZNG	–	32
5	Swivel flange SNC	–	35

1) Shows which accessories can be used within the entire force range. For restricted force ranges see the relevant accessory part, from page 29.

Electric cylinders ESBF, with spindle drive

Peripherals overview

Mounting attachments and accessories				
	Brief description	Suitable for high forces ¹⁾	→ Page/Internet	
6	Swivel flange SNCS	With parallel motor mounting	-	36
7	Swivel flange SNCL	With parallel motor mounting	-	36
8	Swivel flange SNCB/SNCB-...-R3	With parallel motor mounting, for spherical bearing	-	38
9	Trunnion support LNZG/CRLNZG	For cylinders with trunnion mounting	-	33
10	Clevis foot LSNG	With parallel motor mounting, with spherical bearing	-	40
11	Clevis foot LSNSG	With parallel motor mounting, weld-on, with spherical bearing	-	40
12	Clevis foot LBG	With parallel motor mounting, for spherical bearing	-	40
13	Clevis foot LNG/CRLNG	With parallel motor mounting	-	40
14	Right-angle clevis foot LQG	For rod eye SGS	-	40
15	Rod clevis SGA	For swivel mounting of cylinders	■	41
16	Guide unit EAGF	- For protecting electric cylinders against rotation at high torque loads - Cannot be used in combination with protective bellows kit EADB	-	41
17	Protective bellows kit EADB	- Protects the cylinder (piston rod, seal and bearings) against a wide range of media and thus prevents premature wear - The kit can only be used in combination with an extended piston rod (...E)	■	25
18	Rod eye SGS/CRSGS	With spherical bearing	■	41
19	Coupling piece KSZ	To compensate for radial deviations	-	41
20	Rod clevis SG/CRSG	Permits a swivelling movement of the cylinder in one plane	■	41
21	Self-aligning rod coupler FK	For compensating radial and angular deviations	-	41
22	Flange mounting EAHH	- On the bearing cap - Cannot be used in combination with protective bellows kit EADB	■	30
23	Trunnion mounting kit ZNCM/DAMT	For mounting anywhere along the cylinder profile barrel. Cannot be mounted in the vicinity of the motor with parallel motor mounting	-	39
24	Profile mounting EAHF-...-P	- For mounting the electric cylinder via the profile - Cannot be mounted in the vicinity of the motor when using the parallel kit EAMM-U with some combinations	■	28
25	Proximity sensor SME/SMT-8	For position sensing. Can be integrated in the sensor slot, which means there is no projection	■	42
26	Mounting kit CRSMB	For proximity sensor with T-slot	■	42
27	Sensor rail SAMH	For proximity sensor with T-slot	■	42
28	Blanking screw DAMD-PS	For covering unused mounting threads	■	43
29	Parallel kit EAMM-U	For parallel motor mounting	■	23
30	Axial kit EAMM-A	For axial motor mounting	■	21

1) Shows which accessories can be used within the entire force range. For restricted force ranges see the relevant accessory part, from page 29.

Electric cylinders ESBF, with spindle drive

Technical data

Function

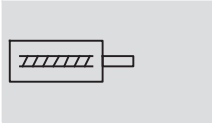

-N- Size
63 ... 100
-T- Stroke length
1 ... 1,500 mm
www.festo.com/en/
Spare_parts_service



General technical data			
Size	63	80	100
Based on standard	ISO 15552		
Design	Electric cylinder with recirculating ball spindle		
Piston rod thread			
Male thread	M16x1.5	M20x1.5	M20x1.5
Female thread	M10	M12	M12
Working stroke [mm]	1 ... 1,200	1 ... 1,500	1 ... 1,500
Protection against rotation/guide	With plain-bearing guide		
Duty cycle [%]	100		
Position sensing	Via proximity sensor		
Type of mounting	Via female thread Via accessories		
Mounting position	Any		

Mechanical data									
Size	63			80			100		
Spindle pitch [mm/rev.]	5	10	25	5	15	32	5	20	40
Spindle diameter [mm]	25			32			40		
Max. force of the cylinder ¹⁾ [kN]	7	7	6	12	12	10	17	17	14.5
Max. driving torque [Nm]	7	13.1	26.5	11.9	33.7	56.6	16.9	63.7	102.6
Max. radial force ²⁾ [N]	700			1,100			1,100		
Max. speed [m/s]	0.27	0.53	1.35	0.21	0.62	1.34	0.16	0.67	1.34
Max. speed [rpm]	3,250	3,220	3,260	2,530	2,515	2,515	2,010	2,010	2,010
Max. acceleration [m/s ²]	5	15	25	5	15	25	5	15	25
Max. angle of rotation at the piston rod [°]	±0.4			±0.5			±0.5		
Reversing backlash ³⁾ [mm]	< 0.03	< 0.03	< 0.04	< 0.03	< 0.03	< 0.04	< 0.03	< 0.03	< 0.04
Repetition accuracy [mm]	±0.015	±0.01							
No-load driving torque ⁴⁾ [Nm]	0.3	0.3	0.4	0.9	1.1	1.3	1.3	1.1	1.5

- 1) The feed force is dependent on the stroke → 8
- 2) At the drive shaft
- 3) In new condition
- 4) At a spindle speed of 200 rpm

Weight [g]			
Size	63	80	100
Basic weight with 0 mm stroke	3,165	7,393	11,123
Additional weight per 10 mm stroke	87	155	193
Moving load with 0 mm stroke	1,831	5,300	8,786
Moving load per 10 mm stroke	52	103	132

Electric cylinders ESBF, with spindle drive

Technical data

Operating and environmental conditions		
Ambient temperature ¹⁾	[°C]	0 ... +50
Storage temperature	[°C]	-25 ... +60
Protection class to IEC 60529		
ESBF-...		IP40
ESBF-...-S1		IP65
Relative air humidity	[%]	0 ... 95 (non-condensing)
Corrosion resistance class CRC ²⁾		
ESBF-...		2
ESBF-...-R3		3
Duty cycle	[%]	100

1) Note operating range of proximity sensors and motors

2) Corrosion resistance class 2 according to Festo standard 940 070

Components subject to moderate corrosion stress. Externally visible parts with primarily decorative surface requirements which are in direct contact with a normal industrial environment or media such as coolants or lubricating agents.

Corrosion resistance class 3 to Festo standard 940 070

Components subject to high corrosion stress. External visible parts in direct contact with industrial atmospheres or media such as solvents and cleaning agents, with a predominantly functional requirement for the surface.

Mass moment of inertia										
Size		63			80			100		
Spindle pitch	[mm/rev.]	5	10	25	5	15	32	5	20	40
J_0 with 0 mm stroke	[kg cm ²]	0.491	0.486	0.650	1.529	1.648	2.119	4.696	5.050	6.170
j_s per metre stroke	[kg cm ² /m]	2.832	2.859	3.053	7.699	7.815	8.277	18.978	19.310	20.372
j_L per kg effective load	[kg cm ² /kg]	0.006	0.025	0.158	0.006	0.057	0.259	0.006	0.101	0.405

The mass moment of inertia J_A of the electric cylinder is calculated as follows:

$$J_A = J_0 + j_s \times \text{working stroke [m]} + j_L \times m_{\text{moving effective load [kg]}}$$

Materials

Sectional view

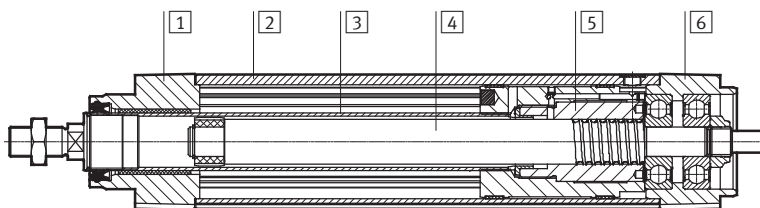

Electric cylinder		
1	Bearing cap	Coated gravity die-cast aluminium
2	Cylinder barrel	Smooth anodised wrought aluminium alloy
3	Piston rod	High-alloy stainless steel
4	Spindle	Rolled steel
5	Spindle nut	Rolled steel
6	Drive cover	Coated die-cast aluminium
-	Note on materials	RoHS-compliant
		Contains PWIS (paint-wetting impairment substances)

Electric cylinders ESBF, with spindle drive

Technical data

Lateral force F_q as a function of stroke length l

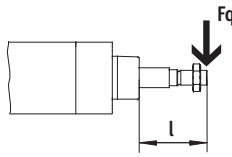
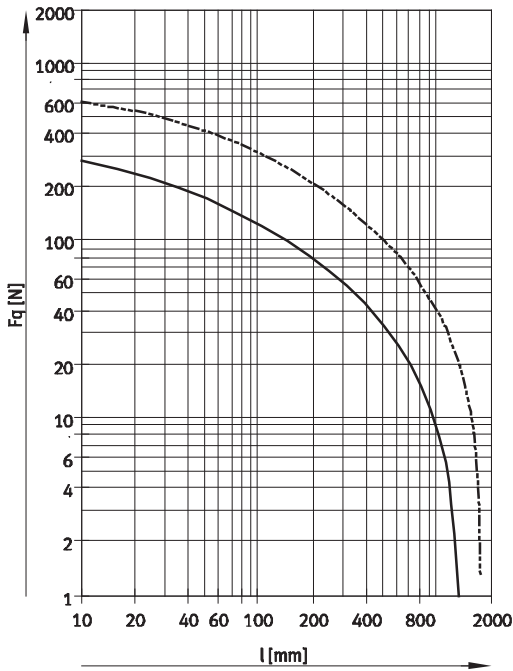

— $\varnothing 63$
 - - - $\varnothing 80/100$

Max. feed force F as a function of stroke length l

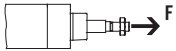

ESBF-BS-63-...

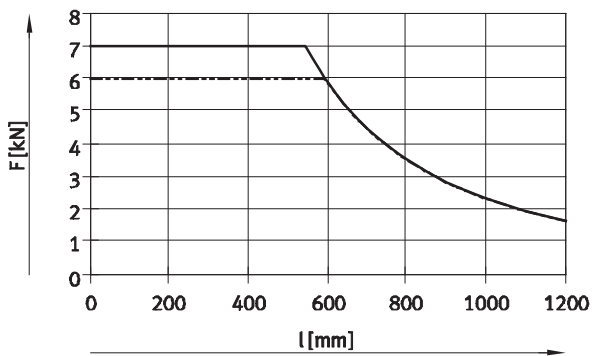

— ESBF-BS-63-...-5P/10P
 - - - ESBF-BS-63-...-25P

ESBF-BS-80-...

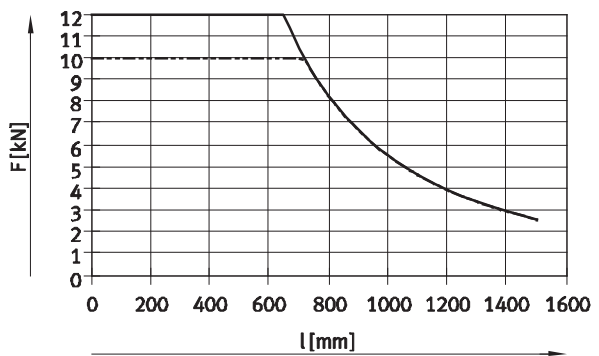

— ESBF-BS-80-...-5P/15P
 - - - ESBF-BS-80-...-32P

ESBF-BS-100-...

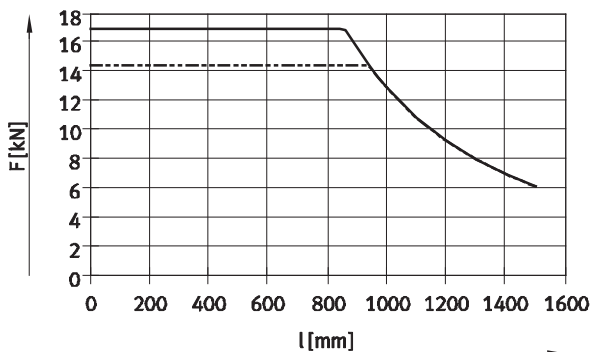

— ESBF-BS-100-...-5P/20P
 - - - ESBF-BS-100-...-40P

Electric cylinders ESBF, with spindle drive

Technical data

Max. feed speed v as a function of stroke length l

ESBF-BS-63-...

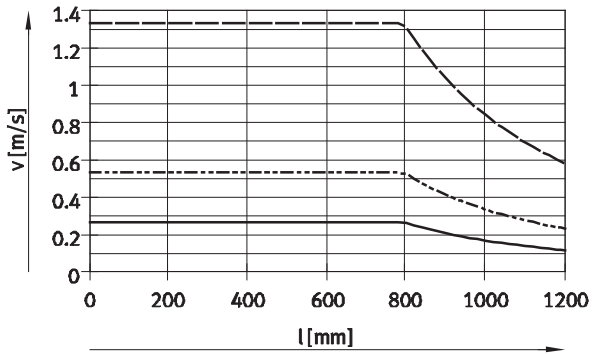

- ESBF-BS-63-...-5P
- - - ESBF-BS-63-...-10P
- · - ESBF-BS-63-...-25P

ESBF-BS-80-...

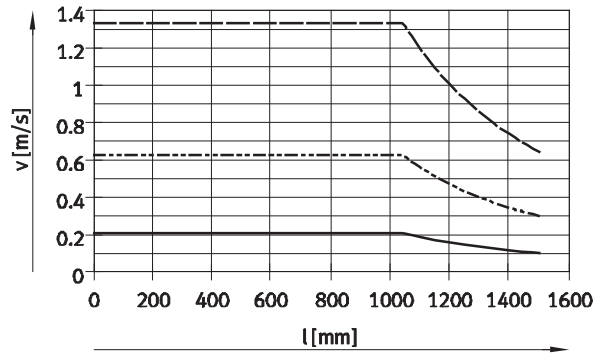

- ESBF-BS-80-...-5P
- - - ESBF-BS-80-...-15P
- · - ESBF-BS-80-...-32P

ESBF-BS-100-...

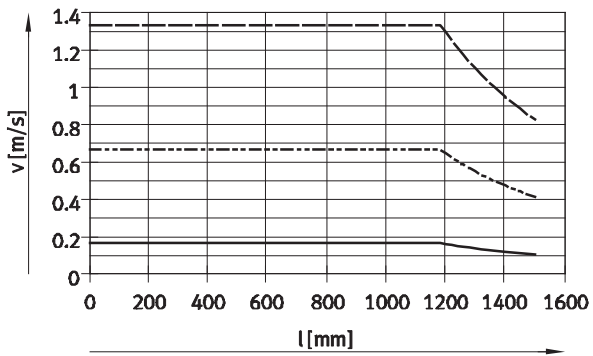

- ESBF-BS-100-...-5P
- - - ESBF-BS-100-...-20P
- · - ESBF-BS-100-...-40P

Electric cylinders ESBF, with spindle drive

Technical data

Axial force F as a function of feed speed v

ESBF-BS-63-...

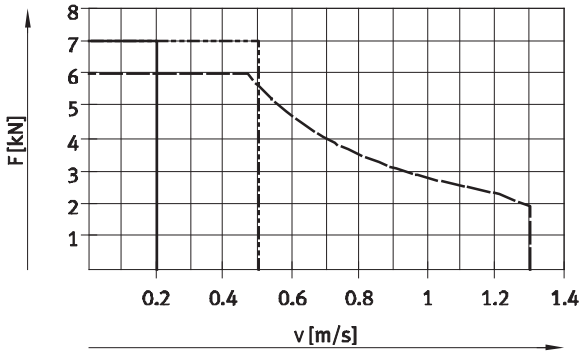

- ESBF-BS-63-...-5P
- - - ESBF-BS-63-...-10P
- · - ESBF-BS-63-...-25P

ESBF-BS-80-...

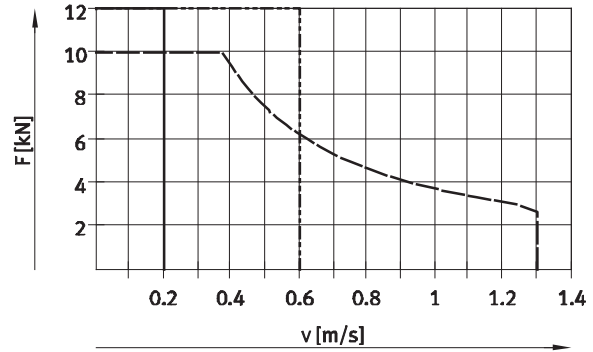

- ESBF-BS-80-...-5P
- - - ESBF-BS-80-...-15P
- · - ESBF-BS-80-...-32P

ESBF-BS-100-...

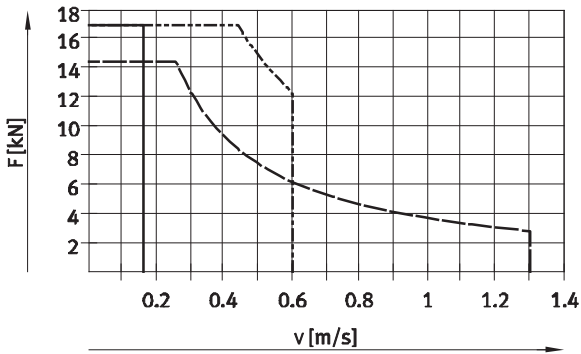

- ESBF-BS-100-...-5P
- - - ESBF-BS-100-...-20P
- · - ESBF-BS-100-...-40P

Electric cylinders ESBF, with spindle drive

Technical data

FESTO

Service life

The service life of the electric cylinder depends considerably on the service life of the recirculating ball spindle.

The service life specifications refer to an operational coefficient of $f_B = 1.0$ (→ table below).

Note

The specifications for running performance are based on experimentally determined and theoretically calculated data.

The running performance attainable in practice can deviate considerably from the specified curves under different parameters.

Mean feed force F as a function of running performance L , with an operational coefficient of 1

$$L_{ist} = \frac{L_0}{f_B^3}$$

L_{ist} = Actual service life

L_0 = Target service life

(→ graph)

f_B = Operational coefficient

Shock load	Operational coefficient f_B	
	For ESBF-...	For ESBF-...-F1 (food industry)
None	1.0	1.4
Lightweight	1.2	1.7
Medium	1.4	2.0
Strong	1.6	2.3

ESBF-BS-63-...

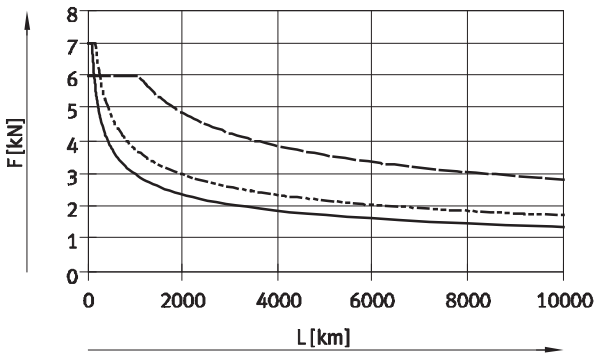

- ESBF-BS-63-...-5P
- - - ESBF-BS-63-...-10P
- · - ESBF-BS-63-...-25P

ESBF-BS-80-...

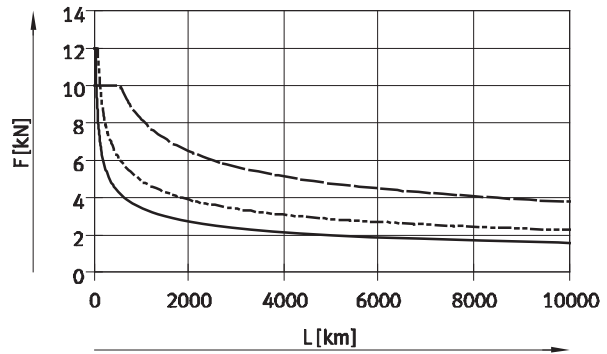

- ESBF-BS-80-...-5P
- - - ESBF-BS-80-...-15P
- · - ESBF-BS-80-...-32P

ESBF-BS-100-...

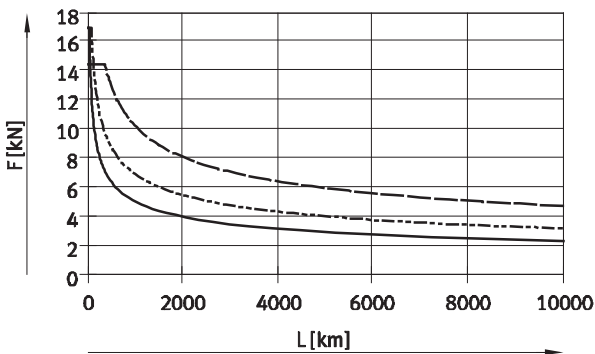

- ESBF-BS-100-...-5P
- - - ESBF-BS-100-...-20P
- · - ESBF-BS-100-...-40P

Electric cylinders ESBF, with spindle drive

Technical data

Friction losses and driving torque

Friction losses

The friction losses comprise the no-load driving torque and the speed-dependent friction losses.

$$M_{\text{reib}} = M_{\text{leerlauf}} + M_{\text{V}}$$

M_{reib} = Friction torque

M_{leerlauf} = No-load driving torque

M_{V} = Speed-dependent friction torque

Driving torque

The driving torque required for the cylinder comprises the friction torque and the effective torque.

$$M_{\text{antrieb}} = M_{\text{reib}} + M_{\text{nutz}}$$

M_{antrieb} = Required driving torque

M_{reib} = Friction torque

M_{nutz} = Effective torque

No-load driving torque¹⁾

Size	63			80			100		
Spindle pitch [mm/rev.]	5	10	25	5	15	32	5	20	40
No-load driving torque [Nm]	0.3	0.3	0.4	0.9	1.1	1.3	1.3	1.1	1.5

1) Corresponds to the required driving torque without load, at a spindle speed of 200 rpm.

Effective torque M_{nutz} as a function of feed force F

ESBF-BS-63-...

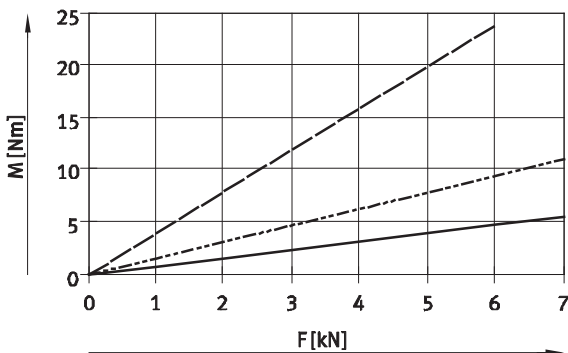

- ESBF-BS-63-...-5P
- - - ESBF-BS-63-...-10P
- · - ESBF-BS-63-...-25P

ESBF-BS-80-...

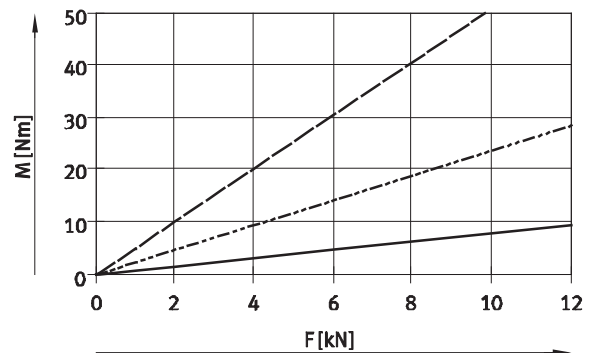

- ESBF-BS-80-...-5P
- - - ESBF-BS-80-...-15P
- · - ESBF-BS-80-...-32P

ESBF-BS-100-...

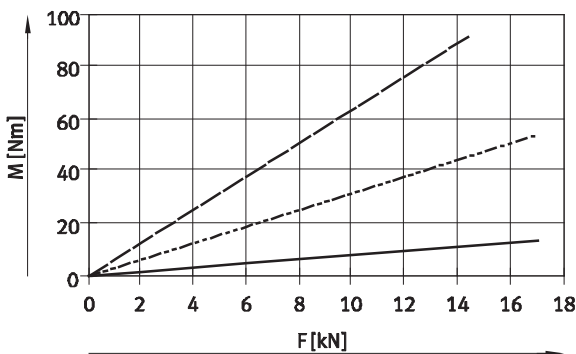

- ESBF-BS-100-...-5P
- - - ESBF-BS-100-...-20P
- · - ESBF-BS-100-...-40P

Electric cylinders ESBF, with spindle drive

Technical data

Friction torque M_f as a function of feed speed v

ESBF-BS-63-...

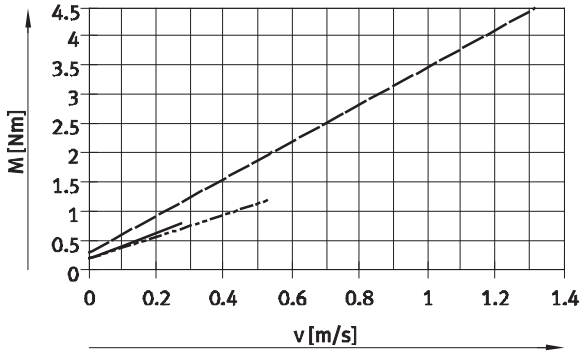

- ESBF-BS-63-...-5P
- - - ESBF-BS-63-...-10P
- · - ESBF-BS-63-...-25P

ESBF-BS-80-...

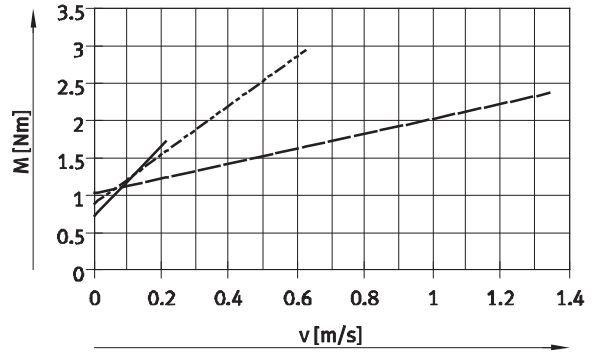

- ESBF-BS-80-...-5P
- - - ESBF-BS-80-...-15P
- · - ESBF-BS-80-...-32P

ESBF-BS-100-...

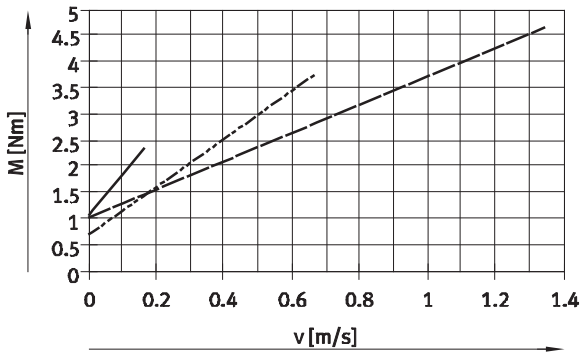

- ESBF-BS-100-...-5P
- - - ESBF-BS-100-...-20P
- · - ESBF-BS-100-...-40P

Electric cylinders ESBF, with spindle drive

Technical data

Dimensions

Download CAD Data → www.festo.com/us/cad

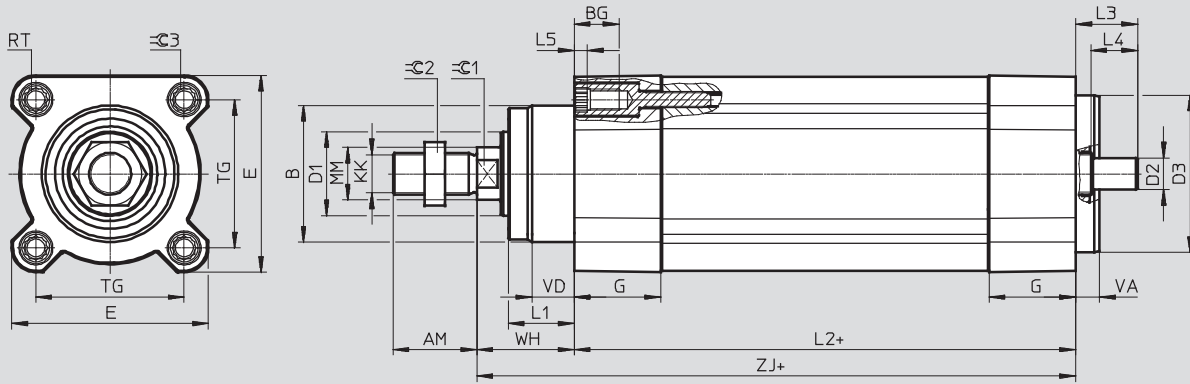

+ = plus stroke length

Size	AM	B	BG	D1	D2	D3	E	G	L1	L2	L3	L4
[mm]	-0.5	∅ d11	min.	∅ h9	∅ h6	∅ f7	+0.5/-0.1	±0.1	-0.5	+0.7/-1.2	±0.5	±0.2
63	32	52	17	32	12	60	75	33	25	171	23.5	17
80	40	60	17	40	19	80	93	39	31	204	33.5	26
100	40	70	17	50	24	100	110	39	34	224	39.5	30

Size	L5	KK	MM	RT	TG	VA	VD	WH	ZJ	∅C1	∅C2	∅C3
[mm]	max.		∅ -0.1		±0.5	±0.2	±0.2	+1.8/-1.7				
63	5	M16x1.5	20	M8	56.5	9	16	37	208	17	24	8
80	25.9	M20x1.5	25	M10	72	10	18	46	250	22	30	6
100	25.9	M20x1.5	25	M10	89	12	20	51	275	22	30	6

Electric cylinders ESBF, with spindle drive

Technical data

Dimensions

Download CAD Data → www.festo.com/us/cad

Variants

...E – Piston rod extension

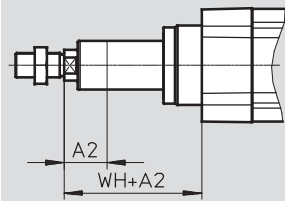

F – Female thread

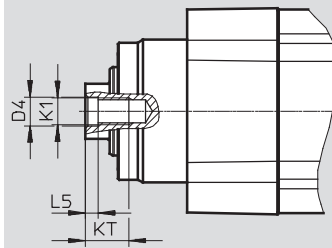

S1 – Protection class IP65/F1 – for the food industry

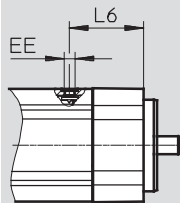

Size	A2	D4	EE	L5	L6	K1	KT	WH
[mm]	max.	∅ +0.1		±0.2			min.	+1.8/-1.7
63	200	10.5	G1/8	4.7	48.5	M10	16	37
80	200	13	G1/8	6.1	57.5	M12	20	46
100	200	13	G1/8	6.1	68.5	M12	20	51

Electric cylinders ESBF, with spindle drive

Technical data

Ordering data – Standard design			
Spindle pitch [m/rev.]	Stroke [mm]	Part No.	Type
ESBF-63			
5	100	574093	ESBF-BS-63-100-5P
	200	1347390	ESBF-BS-63-200-5P
	300	574094	ESBF-BS-63-300-5P
	400	574095	ESBF-BS-63-400-5P
10	100	574096	ESBF-BS-63-100-10P
	200	574097	ESBF-BS-63-200-10P
	300	574098	ESBF-BS-63-300-10P
	400	574099	ESBF-BS-63-400-10P
25	100	574100	ESBF-BS-63-100-25P
	200	574101	ESBF-BS-63-200-25P
	300	574102	ESBF-BS-63-300-25P
	400	574103	ESBF-BS-63-400-25P
ESBF-80			
5	100	574104	ESBF-BS-80-100-5P
	200	1347391	ESBF-BS-80-200-5P
	300	574105	ESBF-BS-80-300-5P
	400	574106	ESBF-BS-80-400-5P
15	100	574107	ESBF-BS-80-100-15P
	200	574108	ESBF-BS-80-200-15P
	300	574109	ESBF-BS-80-300-15P
	400	574110	ESBF-BS-80-400-15P
32	100	574111	ESBF-BS-80-100-32P
	200	574112	ESBF-BS-80-200-32P
	300	574113	ESBF-BS-80-300-32P
	400	574114	ESBF-BS-80-400-32P
ESBF-100			
5	100	574115	ESBF-BS-100-100-5P
	200	1347393	ESBF-BS-100-200-5P
	300	574116	ESBF-BS-100-300-5P
	400	574117	ESBF-BS-100-400-5P
20	100	574118	ESBF-BS-100-100-20P
	200	574119	ESBF-BS-100-200-20P
	300	574120	ESBF-BS-100-300-20P
	400	574121	ESBF-BS-100-400-20P
40	100	574122	ESBF-BS-100-100-40P
	200	574123	ESBF-BS-100-200-40P
	300	574124	ESBF-BS-100-300-40P
	400	574125	ESBF-BS-100-400-40P

Note

 Order variable strokes and variants
via the modular product system

→ 17

Electric cylinders ESBF, with spindle drive

Ordering data – Modular products

Ordering table							
Size	63	80	100	Conditions	Code		Enter code
M Module No.	574090	574091	574092				
Function	Electric cylinder				ESBF		ESBF
Drive type	Ball screw spindle				-BS		-BS
Size	63	80	100		-...		
Stroke [mm]	100				-...		
	200						
	300						
	400						
	1 ... 1,200	1 ... 1,500					
Spindle pitch [mm]	5	5	5		-...P		
	10	-	-				
	-	15	-				
	-	-	20				
	25	-	-				
	-	32	-				
	-	-	40				
	-	-	-				
O Piston rod thread type	Male thread						
	Female thread				-F		
Protection class for electrics	Standard						
	IP65				-S1		
Corrosion protection	Standard						
	High corrosion protection			1	-R3		
Additional features	None						
	Suitable for use in the food industry			2	-F1		
Piston rod extension	None						
	1 ... 200				-...E		

1 R3 Only with S1

2 F1 Only with R3 and S1

NSF-H1 lubricant for piston rod, screw spindle, etc. → declaration of conformity (www.festo.com/net/Support Portal)

Transfer order code

Electric cylinders ESBF, with spindle drive

Accessories

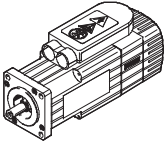
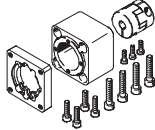
Permissible axis/motor combinations with axial kit		Technical data → Internet: eamm-a	
Motor/motor unit	Axial kit		
			
Type	Part No.	Type	
ESBF-63			
With servo motor			
EMMS-AS-70-...	543161	EAMM-A-D60-70A	
	1679566	EAMM-A-D60B-70A-S1 ¹⁾	
EMMS-AS-100-...	550983	EAMM-A-D60-100A	
	1679518	EAMM-A-D60B-100A-S1 ¹⁾	
With gear unit			
EMGA-60	560283	EAMM-A-D60-60G	
ESBF-80			
With servo motor			
EMMS-AS-100-...	1589665	EAMM-A-D80-100A	
	1600673	EAMM-A-D80B-100A-S1 ¹⁾	
EMMS-AS-140-...	1588299	EAMM-A-D80-140A	
	1600674	EAMM-A-D80B-140A-S1 ¹⁾	
ESBF-100			
With servo motor			
EMMS-AS-140-...	1588349	EAMM-A-D100-140A	
	1600675	EAMM-A-D100B-140A-S1 ¹⁾	

1) With protection class IP65

Note

The following tool is available for sizing:



PositioningDrives
sizing software

→ www.festo.com

Electric cylinders ESBF, with spindle drive

Accessories

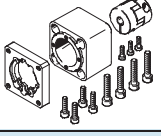
FESTO

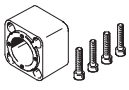
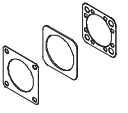
Component parts of the axial kit				
Axial kit	Comprising:			
	Motor flange	Coupling	Coupling housing	Seal set
				
Part No. Type	Part No. Type	Part No. Type	Part No. Type	Part No. Type
ESBF-63				
543161 EAMM-A-D60-70A	529945 EAMF-A-64A/B-70A	543424 EAMC-42-50-11-12	552160 EAMK-A-D60-64B	–
1679566 EAMM-A-D60B-70A-S1				1679570 EADS-F-D60B-70A
550983 EAMM-A-D60-100A	529947 EAMF-A-64A/C/D-100A	551005 EAMC-42-50-12-19	551007 EAMK-A-D60-64C	–
1679518 EAMM-A-D60B-100A-S1				1679522 EADS-F-D60B-100A
560283 EAMM-A-D60-60G	550987 EAMF-A-64A/B-60G	543424 EAMC-42-50-11-12	552160 EAMK-A-D60-64B	–
ESBF-80				
1589665 EAMM-A-D80-100A	1593628 EAMF-A-77A-100A	1485673 EAMC-56-58-19-19	1593627 EAMK-A-D80-77A	–
1600673 EAMM-A-D80B-100A-S1				1593617 EADS-F-D80B-100A
1588299 EAMM-A-D80-140A	1593636 EAMF-A-77A-140A	1485674 EAMC-56-58-19-24	1593627 EAMK-A-D80-77A	–
1600674 EAMM-A-D80B-140A-S1				1593671 EADS-F-D80B-140A
ESBF-100				
1588349 EAMM-A-D100-140A	1593636 EAMF-A-77A-140A	1451407 EAMC-67-62-24-24	1593914 EAMK-A-D100-77A/B	–
1600675 EAMM-A-D100B-140A-S1				1593991 EADS-F-D100B-140A

Electric cylinders ESBF, with spindle drive

Accessories

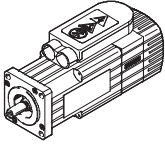
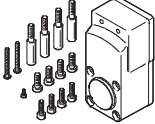
Permissible axis/motor combinations with parallel kit		Technical data → Internet: eamm-u
Motor/motor unit	Parallel kit	
		<ul style="list-style-type: none"> • Space-saving gravity die-cast housing
Type	Part No.	Type
ESBF-63		
With servo motor		
EMMS-AS-70-...	543165	EAMM-U-D60-70A

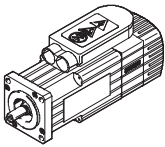
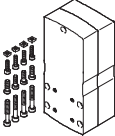
Permissible axis/motor combinations with parallel kit		Technical data → Internet: eamm-u
Motor/motor unit	Parallel kit	
		<ul style="list-style-type: none"> • Increased housing rigidity • More flexible motor mounting possible • Optionally with protection class IP65 • Use in combination with third-party motors on request
Type	Part No.	Type
ESBF-63		
With servo motor		
EMMS-AS-70-...	1212477	EAMM-U-86-D60-70A-102
	1212835	EAMM-U-86-D60-70A-102-S1 ¹⁾
EMMS-AS-100-...	1202436	EAMM-U-110-D60-100A-120
	1203112	EAMM-U-110-D60-100A-120-S1 ¹⁾
With gear unit		
EMGA-60-P-...	1586347	EAMM-U-86-D60-60G-102
	1437163	EAMM-U-86-D60-60G-102-S1 ¹⁾
EMGA-60-P-...	1543240	EAMM-U-110-D60-60G-120
	1436183	EAMM-U-110-D60-60G-120-S1 ¹⁾
EMGA-80-P-...	1532949	EAMM-U-110-D60-80G-120
	1530875	EAMM-U-110-D60-80G-120-S1 ¹⁾

1) With protection class IP65

Note

The clamping component EADT is required to adjust the toothed belt pretension with EAMM-U-110.

The motor and/or axis shaft can optionally be supported with a counter bearing EAMG. More information → eamm-u

Electric cylinders ESBF, with spindle drive

Accessories

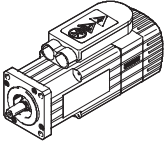
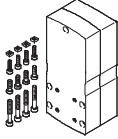
Permissible axis/motor combinations with parallel kit		Technical data → Internet: eamm-u
Motor/motor unit	Parallel kit	
		<ul style="list-style-type: none"> • Increased housing rigidity • More flexible motor mounting possible • Optionally with protection class IP65 • Use in combination with third-party motors on request
Type	Part No.	Type
ESBF-80		
With servo motor		
EMMS-AS-100-...	1465438	EAMM-U-110-D80-100A-120
	1433650	EAMM-U-110-D80-100A-120-S1 ¹⁾
EMMS-AS-140-...	1465530	EAMM-U-145-D80-140A-188
	1433709	EAMM-U-145-D80-140A-188-S1 ¹⁾
With gear unit		
EMGA-80-P-...	1589614	EAMM-U-110-D80-80G-120
	1589706	EAMM-U-110-D80-80G-120-S1 ¹⁾
ESBF-100		
With servo motor		
EMMS-AS-140-...	1465541	EAMM-U-145-D100-140A-188
	1433852	EAMM-U-145-D100-140A-188-S1 ¹⁾

1) With protection class IP65

Note

The clamping component EADT is required to adjust the toothed belt pretension with EAMM-U-110 and EAMM-U-145.

The motor and/or axis shaft can optionally be supported with a counter bearing EAMG.
More information → eamm-u

Electric cylinders ESBF, with spindle drive

Accessories

Protective bellows kit EADB



General technical data		
Type EADB-V2-	63	80
Max. stroke range of cylinder ¹⁾	[mm]	10 ... 500
Type of mounting	Slip-on Via threaded pin	
Mounting position	Any	
Resistance to media	Dust, chippings, oil, grease, fuel (→ Internet: Resistance to media)	
Ambient temperature ²⁾	[°C]	-10 ... +80
Protection class to IEC 60529	IP65	
Corrosion resistance class CRC ³⁾	3	

- 1) In combination with the protective bellows kit EADB
- 2) Note operating range of proximity sensors and cylinder
- 3) Corrosion resistance class 3 according to Festo standard 940 070
Components subject to high corrosion stress. External visible parts in direct contact with industrial atmospheres or media such as solvents and cleaning agents, with a predominantly functional requirement for the surface.

Materials

Sectional view

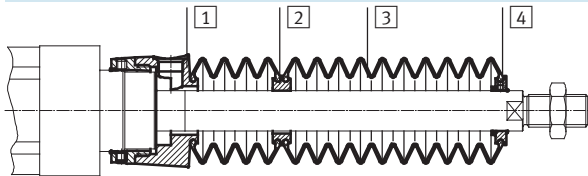

Bellows	
1	Connection Anodised wrought aluminium alloy
2	Adapter Polyamide
3	Bellows Nitrile rubber
4	End piece Anodised wrought aluminium alloy
-	O-ring Nitrile rubber
Note on materials Free of copper and PTFE RoHS-compliant	

Weight [g]		
Type EADB-V2-	63	80
Stroke [mm]		
Product weight		
10 ... 100	203	269
101 ... 200	265	327
201 ... 300	307	365
301 ... 400	370	423
401 ... 500	391	444
Moving load		
10 ... 100	79	72
101 ... 200	142	130
201 ... 300	183	168
301 ... 400	246	226
401 ... 500	267	247

Electric cylinders ESBF, with spindle drive

Accessories

Travel speed v as a function of tubing length l



The bellows kit is a leak-free system. To prevent unwanted media from being drawn in, the supply and exhaust air must be ducted via a pressure compensation hole in the connection part **1**.

The pressure generated in the protective bellows kit by the positioning motion is primarily defined by the travel speed and tubing

length. The recommended tubing length based on the travel speed of the drive can be read from the graph.

For size 63

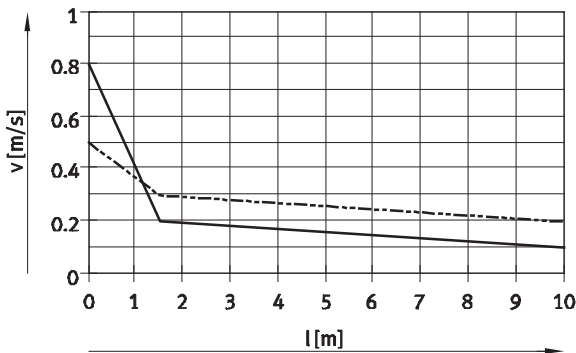

— EADB-V2-63/tubing Ø 12 mm
 - - - EADB-V2-63/tubing Ø 16 mm

For size 80

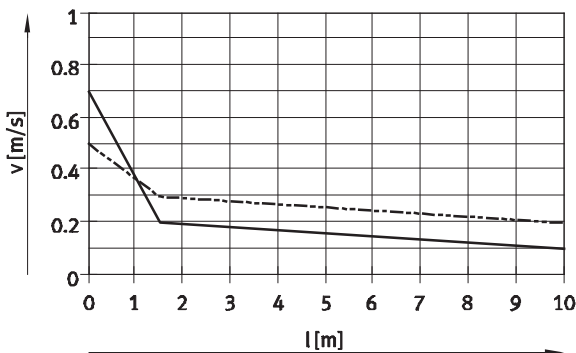

— EADB-V2-80/tubing Ø 12 mm
 - - - EADB-V2-80/tubing Ø 16 mm

Note

The push-in fittings opposite must be used for the pressure compensation hole.

Silencers can be used as an alternative. This reduces the travel speed slightly.

Tubing length and push-in fitting for pressure compensation hole			
Ø [mm]	Tubing O.D. [mm]	Push-in fitting	
		Part No.	Type
63, 80	16	186350	QS-G¼-12
		153261	QSH-16-12
		533848	QS-F-G¼-12
		153261	QSH-16-12

Electric cylinders ESBF, with spindle drive

Accessories

Dimensions

Download CAD Data → www.festo.com/us/cad

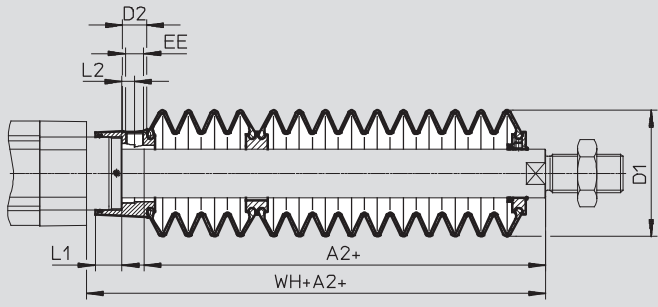

+ = plus stroke length

∅ Stroke [mm]	63						
	A2 ¹⁾	D1 max.	D2	EE	L1	L2	WH+A2
10 ... 100	45	93	17	G¼	18.9	9	82
101 ... 200	70						107
201 ... 300	82						119
301 ... 400	106						143
401 ... 500	119						156

∅ Stroke [mm]	80						
	A2 ¹⁾	D1 max.	D2	EE	L1	L2	WH+A2
10 ... 100	48	93	17	G¼	21.9	12	94
101 ... 200	73						119
201 ... 300	85						131
301 ... 400	109						155
401 ... 500	122						168

1) The dimension corresponds to the E value (piston rod extension) of the cylinder

Ordering data – Protective bellows kit

An extended piston rod (order code ...E) → 17 is absolutely essential if a protective bellows kit is to be used.

The necessary dimensions for ...E as a function of cylinder size and stroke as well as the corresponding protective bellows kit are indicated in the following table:

Order example:

Selected electric cylinder:

ESBF-BS-63-250-5P-...E

The dimension for the corresponding E value (see table):

82 mm

Complete type code for electric cylinder:

ESBF-BS-63-250-5P-82E

The corresponding protective bellows kit:

EADB-V2-63-S201-300

Cylinder data			Protective bellows kit	
∅ [mm]	Stroke [mm]	Dimension for ...E [mm]	Part No.	Type
63	10 ... 100	45	1488361	EADB-V2-63-S10-100
	101 ... 200	70	1488362	EADB-V2-63-S101-200
	201 ... 300	82	1488363	EADB-V2-63-S201-300
	301 ... 400	106	1488364	EADB-V2-63-S301-400
	401 ... 500	119	1488365	EADB-V2-63-S401-500

Cylinder data			Protective bellows kit	
∅ [mm]	Stroke [mm]	Dimension for ...E [mm]	Part No.	Type
80	10 ... 100	48	1489406	EADB-V2-80-S10-100
	101 ... 200	73	1489407	EADB-V2-80-S101-200
	201 ... 300	85	1489408	EADB-V2-80-S201-300
	301 ... 400	109	1489409	EADB-V2-80-S301-400
	401 ... 500	122	1489410	EADB-V2-80-S401-500

Electric cylinders ESBF, with spindle drive

Accessories

FESTO

Profile mounting EAHF

Material:

RoHS-compliant

Plate: Anodised aluminium

Clamping piece: Galvanised steel

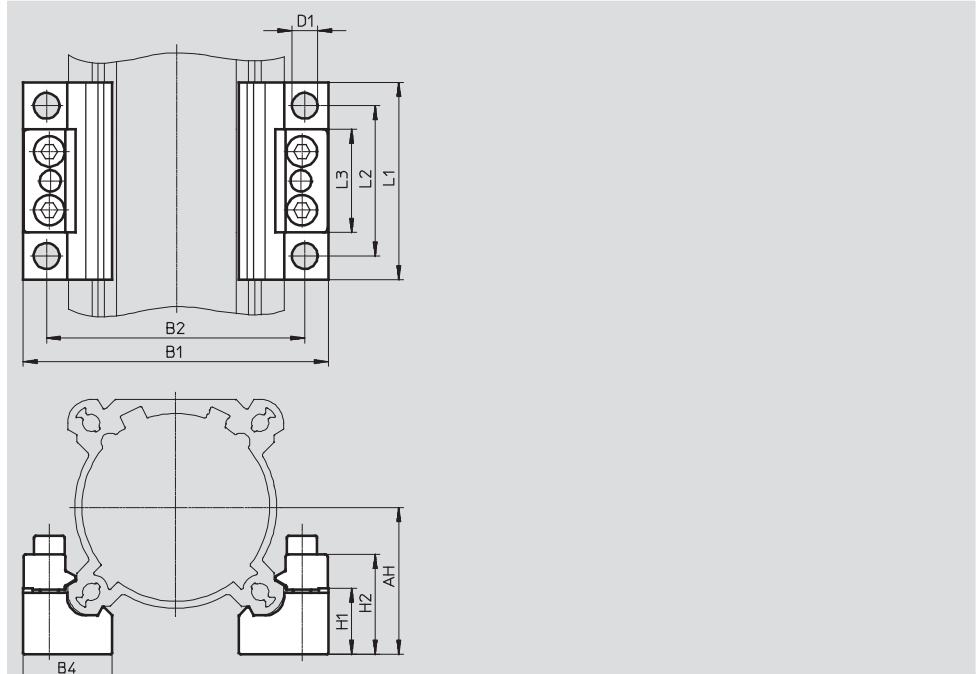
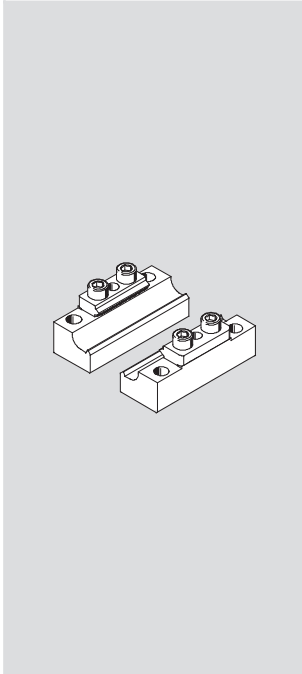

Dimensions and ordering data										
For size	AH	B1	B2	B4	D1	H1	H2	L1	L2	L3
[mm]					∅					
63	50	105	92	30	9	22.8	30.4	80	60	41
80	63	130	110	38	11	28.1	42.5	84	64	44
100	71	147	127	38	11	28.1	42.5	84	64	44

For size	Max. load capacity per pair	CRC ¹⁾	Weight	Part No.	Type
[mm]	[kN]		[g]		
63	3.5	3	740	1547781	EAHF-V2-50/63-P
80, 100	6	3	630	1547780	EAHF-V2-80/100-P

1) Corrosion resistance class 3 according to Festo standard 940 070
 Components subject to high corrosion stress. External visible parts in direct contact with industrial atmospheres or media such as solvents and cleaning agents, with a predominantly functional requirement for the surface.

Electric cylinders ESBF, with spindle drive

Accessories

**Foot mounting HNC/CRHNC,
for parallel motor attachment**

Material:
HNC: Galvanised steel

CRHNC: High-alloy steel
Free of copper and PTFE

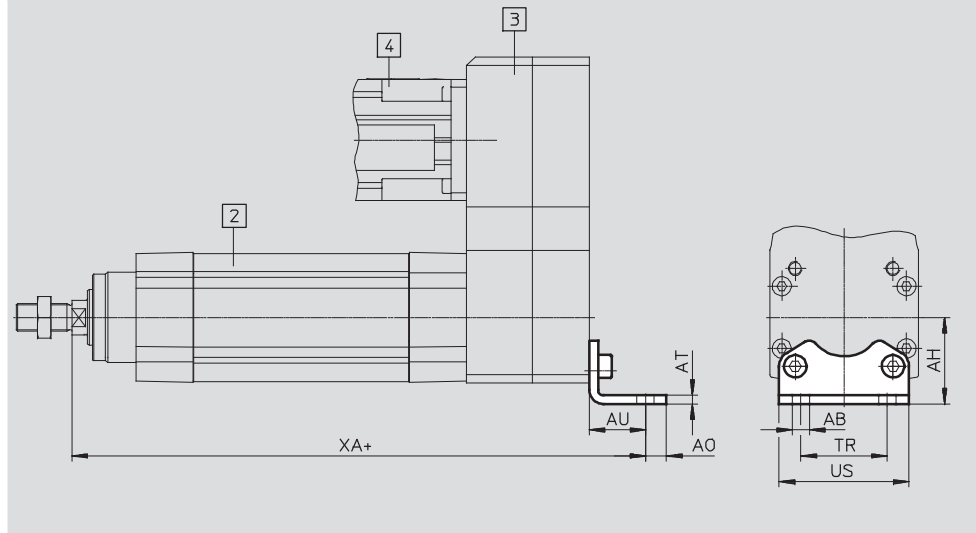

- 2 Electric cylinder ESBF
- 3 Parallel kit EAMM-U
- 4 Motor EMMS-AS
- + = plus stroke length

Note

The foot mounting can only be secured at the rear, on the parallel kit.

Dimensions and ordering data								
For size	AB	AH	AO	AT	AU	TR	US	XA
[mm]	∅							
63	10	50	12.5	5	32	50	75	304
80	12	63	15	6	41	63	93	373
100	14.5	71	17.5	6	41	75	110	415.5

For size	Max. load capacity	Basic design				High corrosion protection			
		CRC ¹⁾	Weight	Part No.	Type	CRC ¹⁾	Weight	Part No.	Type
[mm]	[kN]		[g]				[g]		
63	4	2	436	174372	HNC-63	4	424	176940	CRHNC-63
80	6	2	829	174373	HNC-80	4	809	176941	CRHNC-80
100	9	2	1,009	174374	HNC-100	4	990	176942	CRHNC-100

1) Corrosion resistance class 2 according to Festo standard 940 070
 Components subject to moderate corrosion stress. Externally visible parts with primarily decorative surface requirements which are in direct contact with a normal industrial environment or media such as coolants or lubricating agents.
 Corrosion resistance class 4 according to Festo standard 940 070
 Components subject to very high corrosion stress. Parts used with aggressive media, e.g. in the food or chemical industry. These applications should be supported with special tests with the media if required.

Electric cylinders ESBF, with spindle drive

Accessories

Flange mounting EAHH

Material:
High-alloy stainless steel

RoHS-compliant
Free of copper and PTFE

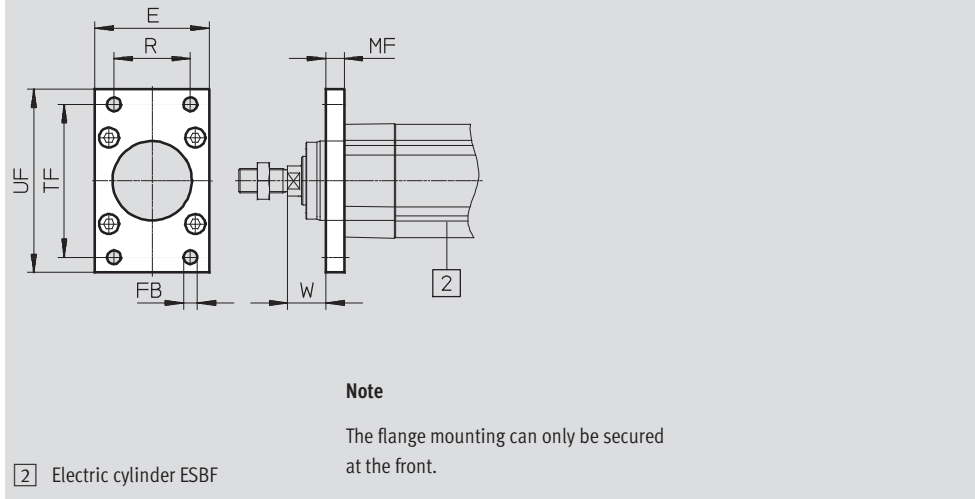

Dimensions and ordering data							
For size	E	FB ∅ H13	MF	R	TF	UF ±1	W
[mm]							
63	75	9	12	50	100	120	25
80	93	12	16	63	126	150	30
100	110	14	16	75	150	175	35

For size	Max. load capacity	High corrosion protection			
		CRC ¹⁾	Weight	Part No.	Type
[mm]	[kN]		[g]		
63	7	3	633	1502305	EAHH-V2-63-R1
80	12	3	1,360	1502306	EAHH-V2-80-R1
100	17	3	1,880	1502307	EAHH-V2-100-R1

1) Corrosion resistance class 3 according to Festo standard 940 070
Components subject to high corrosion stress. External visible parts in direct contact with industrial atmospheres or media such as solvents and cleaning agents, with a predominantly functional requirement for the surface.

Electric cylinders ESBF, with spindle drive

Accessories

Flange mounting FNC/CRFNG

Material:

FNC: Galvanised steel

CRFNG: High-alloy steel

Free of copper and PTFE

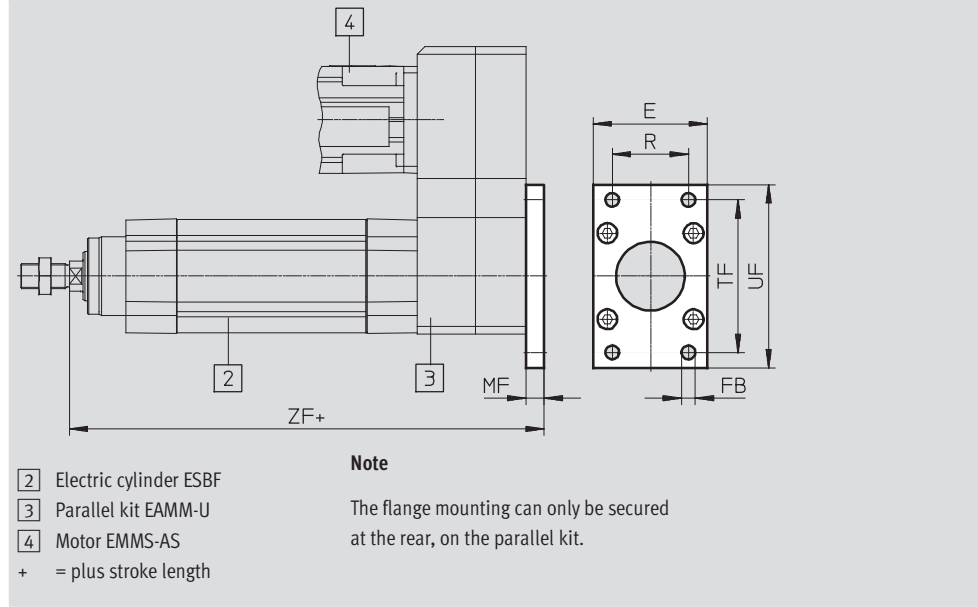

Dimensions and ordering data							
For size	E	FB	MF	R	TF	UF	ZF
[mm]		∅ H13					
63	75	9	12	50	100	120	284
80	93	12	16	63	126	150	348
100	110	14	16	75	150	175	390.5

For size	Max. load capacity	Basic design				High corrosion protection			
		CRC ¹⁾	Weight	Part No.	Type	CRC ¹⁾	Weight	Part No.	Type
[mm]	[kN]		[g]			[g]			
63	7	1	679	174379	FNC-63	4	680	161849	CRFNG-63
80	12	1	1,495	174380	FNC-80	4	1,500	161850	CRFNG-80
100	17	1	2,041	174381	FNC-100	4	2,100	161851	CRFNG-100

1) Corrosion resistance class 1 according to Festo standard 940 070
 Components subject to low corrosion stress. Transport and storage protection. Parts that do not have primarily decorative surface requirements, e.g. in internal areas that are not visible or behind covers.
 Corrosion resistance class 4 according to Festo standard 940 070
 Components subject to very high corrosion stress. Parts used with aggressive media, e.g. in the food or chemical industry. These applications should be supported with special tests with the media if required.

Electric cylinders ESBF, with spindle drive

Accessories

FESTO

Trunnion flange ZNCF/CRZNG

Material:
 ZNCF: Stainless steel casting
 CRZNG: Electropolished stainless steel casting

Free of copper and PTFE

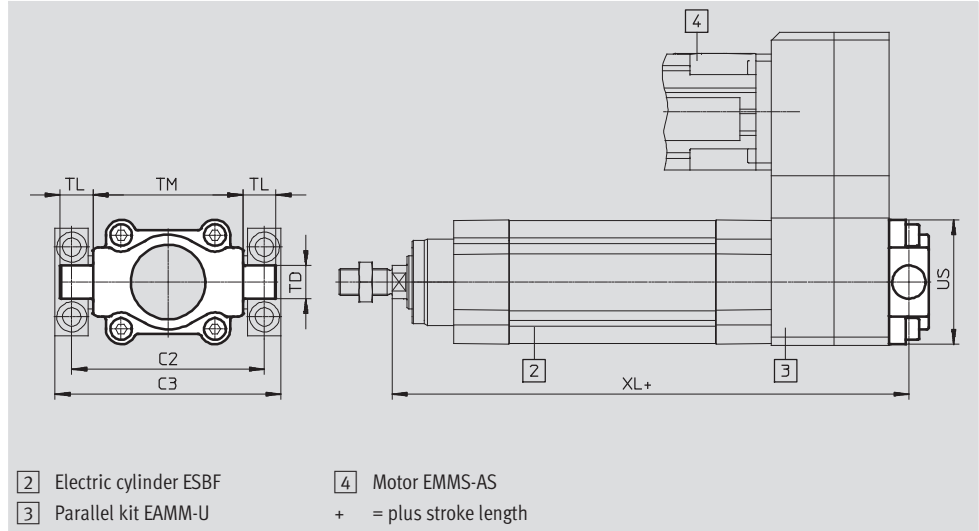

Dimensions and ordering data							
For size	C2	C3	TD	TL	TM	US	XL
[mm]			∅ e9				
63	116	136	20	20	90	75	284
80	136	156	20	19.5	110	93	346
100	164	189	25	24.5	132	110	393.5

For size [mm]	Max. load capacity [kN]	Basic design				High corrosion protection			
		CRC ¹⁾	Weight [g]	Part No.	Type	CRC ¹⁾	Weight [g]	Part No.	Type
63	4	2	687	174414	ZNCF-63	4	687	161855	CRZNG-63
80	6	2	1,296	174415	ZNCF-80	4	1,296	161856	CRZNG-80
100	9	2	2,254	174416	ZNCF-100	4	2,254	161857	CRZNG-100

1) Corrosion resistance class 2 according to Festo standard 940 070
 Components subject to moderate corrosion stress. Externally visible parts with primarily decorative surface requirements which are in direct contact with a normal industrial environment or media such as coolants or lubricating agents.
 Corrosion resistance class 4 according to Festo standard 940 070
 Components subject to very high corrosion stress. Parts used with aggressive media, e.g. in the food or chemical industry. These applications should be supported with special tests with the media if required.

Electric cylinders ESBF, with spindle drive

Accessories

Trunnion support LNZG

Material:
 Trunnion support: Anodised aluminium
 Plain bearing: Plastic
 Free of copper and PTFE

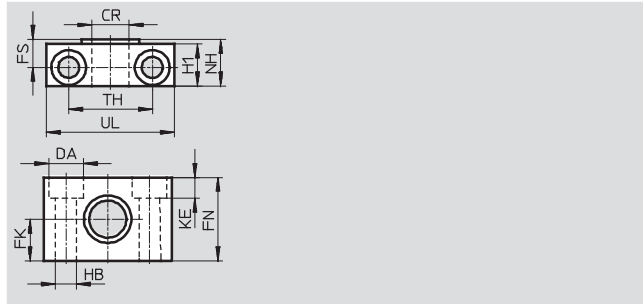

Dimensions and ordering data															
For size	CR	DA	FK	FN	FS	H1	HB	KE	NH	TH	UL	CRC ¹⁾	Weight	Part No.	Type
[mm]	∅	∅	∅				∅			±0.2			[g]		
63, 80	20	18	20	40	13	20	11	11	23	42	65	2	178	32961	LNZG-63/80
100	25	20	25	50	16	24.5	14	13	28.5	50	75	2	306	32962	LNZG-100/125

Trunnion support CRLNZG

Material:
 High-alloy steel
 Free of copper and PTFE

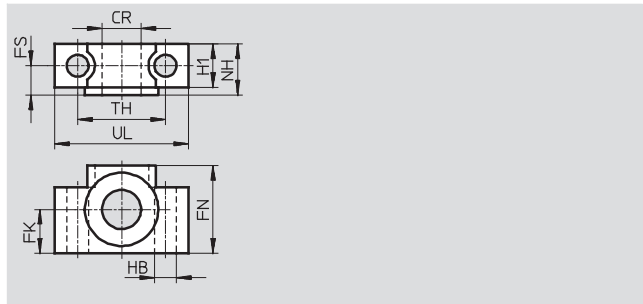
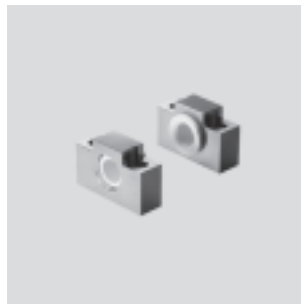

Dimensions and ordering data														
For size	CR	FK	FN	FS	H1	HB	NH	TH	UL	CRC ¹⁾	Weight	Part No.	Type	
[mm]	∅	∅				∅		±0.2			[g]			
63, 80	20	20	40	13	20	11	23	42	65	4	435	161876	CRLNZG-63/80	
100	25	25	50	16	24.5	14	28.5	50	75	4	739	161877	CRLNZG-100/125	

1) Corrosion resistance class 2 according to Festo standard 940 070
 Components subject to moderate corrosion stress. Externally visible parts with primarily decorative surface requirements which are in direct contact with a normal industrial environment or media such as coolants or lubricating agents.
 Corrosion resistance class 4 according to Festo standard 940 070
 Components subject to very high corrosion stress. Parts used with aggressive media, e.g. in the food or chemical industry. These applications should be supported with special tests with the media if required.

Electric cylinders ESBF, with spindle drive

Accessories

FESTO

Swivel flange DAMS

Material:
Aluminium

RoHS-compliant
Free of copper and PTFE

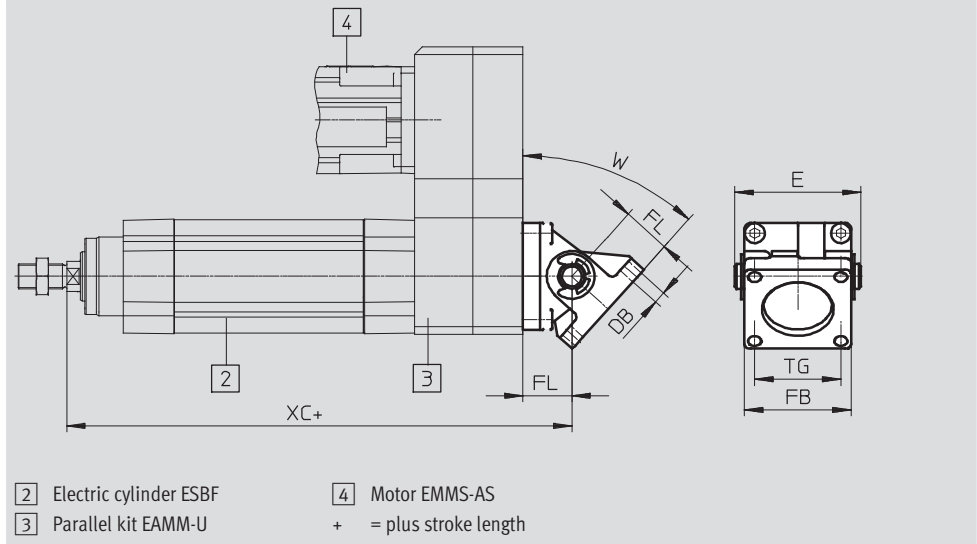

Dimensions and ordering data							
For size	DB	E	FB	FL	TG	UB	XC
[mm]	∅						
63	8.5	83	70	32	56.5	70	240
80	10.5	103	90	36	72	90	286
100	10.5	127	110	41	89	110	316

For size	W max.	Max. load capacity	CRC ¹⁾	Weight	Part No.	Type
[mm]	[°]	[kN]		[g]		
63	42	7	3	657	1555443	DAMS-K-V1-63-V-R3
80	31	12	3	1,240	1556588	DAMS-K-V1-80-V-R3
100	36	17	3	1,940	1560237	DAMS-K-V1-100-V-R3

1) Corrosion resistance class 3 according to Festo standard 940 070
Components subject to high corrosion stress. External visible parts in direct contact with industrial atmospheres or media such as solvents and cleaning agents, with a predominantly functional requirement for the surface.

Electric cylinders ESBF, with spindle drive

Accessories

Swivel flange SNC

Material:
Die-cast aluminium

Free of copper and PTFE

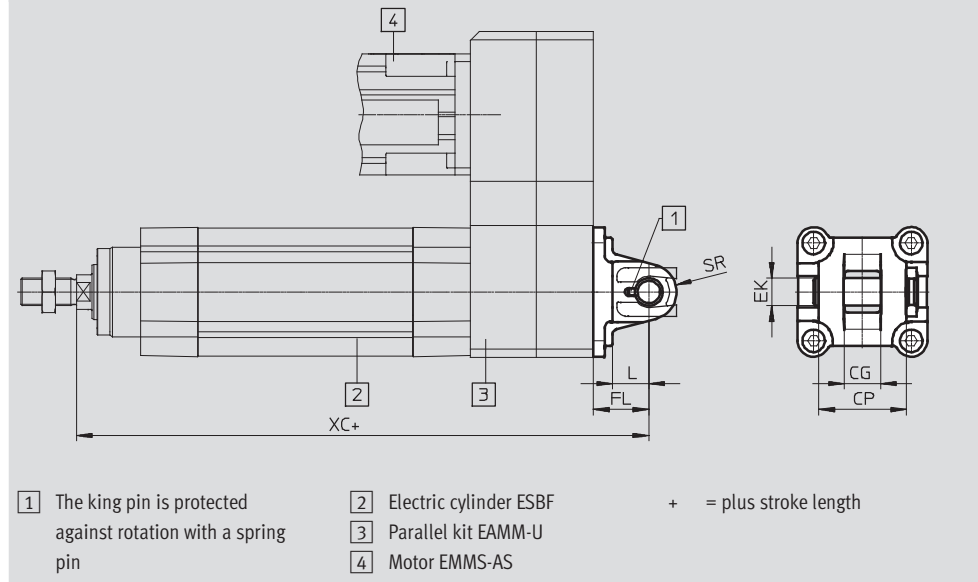

Dimensions and ordering data							
For size	CG	CP	EK	FL	L	SR	XC
[mm]	H14	h14	∅	±0.2			
63	21	51	16	32	21	16	304
80	25	65	20	36	22	16	368
100	25	75	20	41	27	20	415.5

For size	Max. load capacity	CRC ¹⁾	Weight	Part No.	Type
[mm]	[kN]		[g]		
63	4	2	320	174386	SNC-63
80	6	2	625	174387	SNC-80
100	9	2	830	174388	SNC-100

1) Corrosion resistance class 2 according to Festo standard 940 070
Components subject to moderate corrosion stress. Externally visible parts with primarily decorative surface requirements which are in direct contact with a normal industrial environment or media such as coolants or lubricating agents.

Electric cylinders ESBF, with spindle drive

Accessories

Swivel flange SNCS

Material: Free of copper and PTFE
Die-cast aluminium

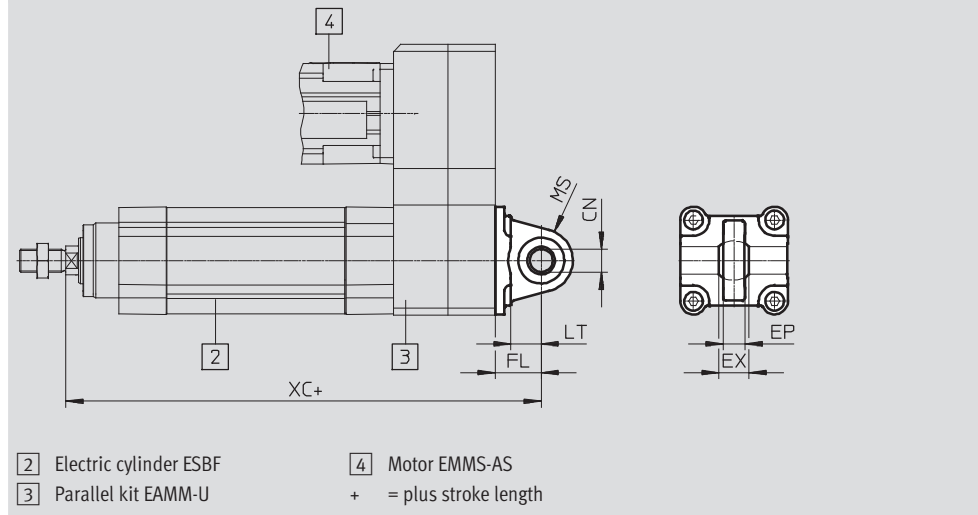
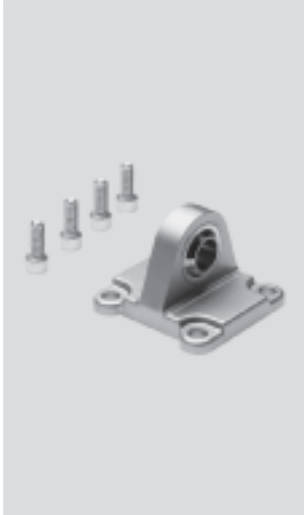

Dimensions and ordering data												
For size	CN	EP	EX	FL	LT	MS	XC	Max. load capacity	CRC ¹⁾	Weight	Part No.	Type
[mm]	∅ H7	+0.2		±0.2				[kN]		[g]		
63	16	15	21	32	21	22	304	4	2	280	174400	SNCS-63
80	20	18	25	36	22	27	368	6	2	540	174401	SNCS-80
100	20	18	25	41	27	29	415.5	9	2	700	174402	SNCS-100

Swivel flange SNCL

Material: Free of copper and PTFE
Die-cast aluminium

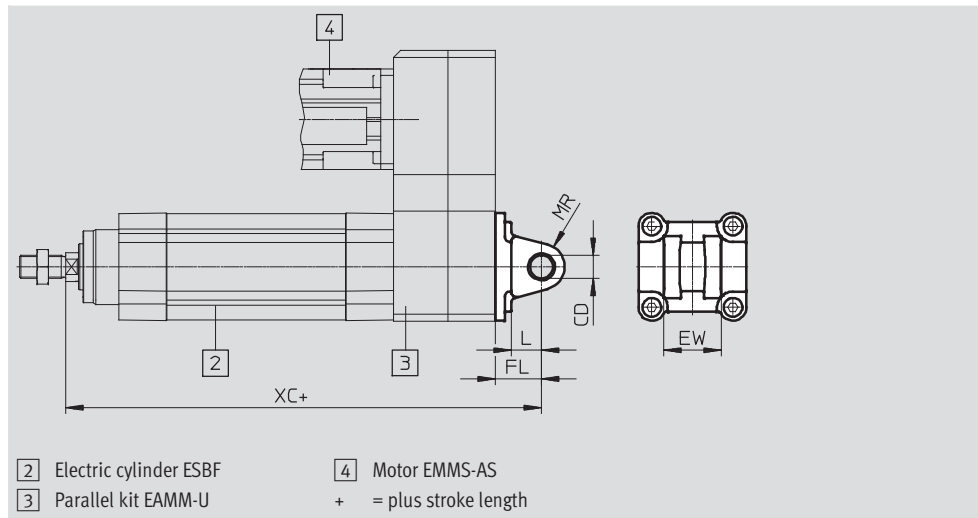

Dimensions and ordering data												
For size	CD	EW	FL	L	MR	XC	Max. load capacity	CRC ¹⁾	Weight	Part No.	Type	
[mm]	∅ H9	h12	±0.2				[kN]		[g]			
63	16	40	32	21	16	304	4	2	250	174407	SNCL-63	
80	16	50	36	22	16	368	6	2	405	174408	SNCL-80	
100	20	60	41	27	20	415.5	9	2	655	174409	SNCL-100	

1) Corrosion resistance class 2 according to Festo standard 940 070
Components subject to moderate corrosion stress. Externally visible parts with primarily decorative surface requirements which are in direct contact with a normal industrial environment or media such as coolants or lubricating agents.

Electric cylinders ESBF, with spindle drive

Accessories

Swivel flange
SNCB/SNCB-...-R3

Material:
SNCB: Die-cast aluminium
SNCB-...-R3: Die-cast aluminium with protective coating, high corrosion protection

Free of copper and PTFE

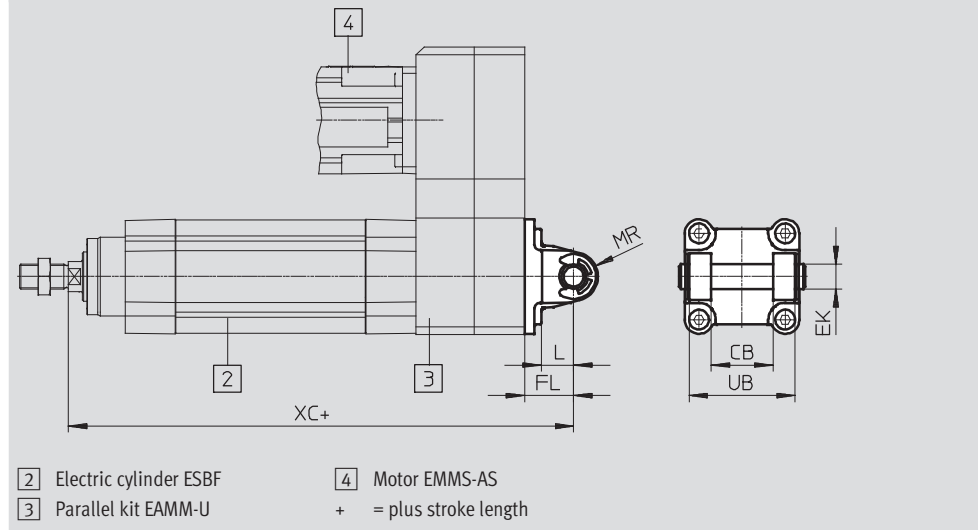

Dimensions and ordering data							
For size	CB	EK	FL	L	MR	UB	XC
[mm]	H14	∅ e8	±0.2			h14	
63	40	16	32	21	16	70	304
80	50	16	36	22	16	90	368
100	60	20	41	27	20	110	415.5

For size	Max. load capacity	Basic design				Variant R3 – High corrosion protection			
		CRC ¹⁾	Weight	Part No.	Type	CRC ¹⁾	Weight	Part No.	Type
[mm]	[kN]		[g]				[g]		
63	4	2	375	174393	SNCB-63	3	371	176947	SNCB-63-R3
80	6	2	636	174394	SNCB-80	3	632	176948	SNCB-80-R3
100	9	2	1,035	174395	SNCB-100	3	986	176949	SNCB-100-R3

1) Corrosion resistance class 2 according to Festo standard 940 070
Components subject to moderate corrosion stress. Externally visible parts with primarily decorative surface requirements which are in direct contact with a normal industrial environment or media such as coolants or lubricating agents.
Corrosion resistance class 3 according to Festo standard 940 070
Components subject to high corrosion stress. Externally visible parts with primarily functional surface requirements which are in direct contact with a normal industrial environment or media such as solvents and cleaning agents.

Electric cylinders ESBF, with spindle drive

Accessories



Trunnion mounting kit ZNCM/DAMT

Material:
Galvanised steel

The mounting kit can be attached at any position along the profile barrel of the cylinder.

The trunnion mounting kit cannot be

mounted in the vicinity of the motor when used in combination with the parallel kit EAMM-U.

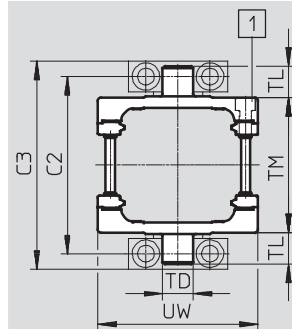

- 1 Max. tightening torque
- 2 Electric cylinder ESBF

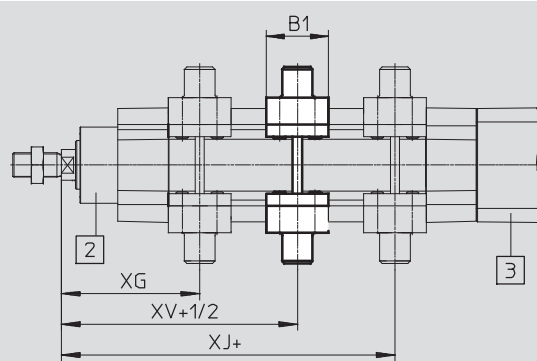



- 3 Axial kit EAMM-A
- + = plus stroke length
- +1/2 = plus stroke length

Dimensions and ordering data								
For size	B1	C2	C3	TD	TL	TM	UW	XG
[mm]				∅ e9				
63	41	116	136	20	20	90	105	90.5
80	44	136	156	20	20	110	130	107
100	48	164	189	25	25	132	145	114

For size	XJ	XV	Max. tightening torque [Nm]	Max. load capacity [kN]	CRC ¹⁾	Weight [g]	Part No.	Type
[mm]								
63	187.5	122.5	18+2	4	1	931	163528	ZNCM-63
80	228	148	28+2	6	1	1,494	163529	DAMT-V1-80-A
100	251	163	28+2	9	1	2,095	163530	DAMT-V-100-A

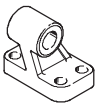
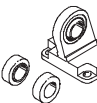
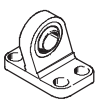

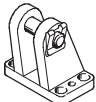
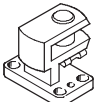

1) Corrosion resistance class 1 according to Festo standard 940 070
Components subject to low corrosion stress. Transport and storage protection. Parts that do not have primarily decorative surface requirements, e.g. in internal areas that are not visible or behind covers.

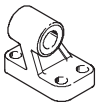

Ordering data – Mounting attachments				Technical data → Internet: clevis foot			
Designation	For size	Part No.	Type	Designation	For size	Part No.	Type
Clevis foot LNG				Clevis foot LSN			
	63	33893	LNG-63		63	5564	LSN-63
	80	33894	LNG-80		80	5565	LSN-80
	100	33895	LNG-100		100	5566	LSN-100
Clevis foot LSNG				Clevis foot LSNSG			
	63	31743	LSNG-63		63	31750	LSNSG-63
	80	31744	LSNG-80		80	31751	LSNSG-80
	100	31745	LSNG-100		100	31752	LSNSG-100
Clevis foot LBG				Right-angle clevis foot LQG			
	63	31764	LBG-63		63	31771	LQG-63
	80	31765	LBG-80		80	31772	LQG-80
	100	31766	LBG-100		100	31773	LQG-100

Electric cylinders ESBF, with spindle drive

Accessories

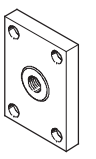
Ordering data – Mounting attachments, corrosion-resistant			Technical data → Internet: clevis foot	
Designation	For size	Part No.	Type	
Clevis foot CRLNG				
	63	161843	CRLNG-63	
	80	161844	CRLNG-80	
	100	161845	CRLNG-100	

Ordering data – Piston rod attachments				Technical data → Internet: piston rod attachment			
Designation	For size	Part No.	Type	Designation	For size	Part No.	Type
Rod eye SGS				Rod clevis SGA			
	63	9263	SGS-M16x1,5		63	10768	SGA-M16x1,5
	80, 100	9264	SGS-M20x1,5		80, 100	10769	SGA-M20x1,5
Rod clevis SG				Self-aligning rod coupler FK			
	63	6146	SG-M16x1,5		63	6142	FK-M16x1,5
	80, 100	6147	SG-M20x1,5		80, 100	6143	FK-M20x1,5
Coupling piece KSZ				Note			
	63	36127	KSZ-M16x1,5	The maximum force of 10 kN must not be exceeded when using the piston-rod attachments.			
	80, 100	36128	KSZ-M20x1,5				

Ordering data – Piston rod attachments, corrosion-resistant				Technical data → Internet: piston rod attachment			
Designation	For size	Part No.	Type	Designation	For size	Part No.	Type
Rod eye CRSGS				Rod clevis CRSG			
	63	195584	CRSGS-M16x1,5		63	13571	CRSG-M16x1,5
	80, 100	195585	CRSGS-M20x1,5		80, 100	13572	CRSG-M20x1,5

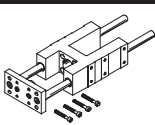
Ordering data – Guide units				Technical data → Internet: eagf			
Designation	Stroke [mm]	Part No.	Type	Designation	Stroke [mm]	Part No.	Type
	For size 63			For size 100			
	10 ... 100	1725842	EAGF-V2-KF-63-100	10 ... 100	1725850	EAGF-V2-KF-100-100	
	10 ... 200	1725843	EAGF-V2-KF-63-200	10 ... 200	1725851	EAGF-V2-KF-100-200	
	10 ... 320	1725844	EAGF-V2-KF-63-300	10 ... 320	1725852	EAGF-V2-KF-100-300	
	10 ... 400	1725845	EAGF-V2-KF-63-400	10 ... 400	1725853	EAGF-V2-KF-100-400	
	For size 80						
	10 ... 100	1725846	EAGF-V2-KF-80-100				
	10 ... 200	1725847	EAGF-V2-KF-80-200				
	10 ... 320	1725848	EAGF-V2-KF-80-300				
	10 ... 400	1725849	EAGF-V2-KF-80-400				

Electric cylinders ESBF, with spindle drive

Accessories

Sensor mounting

The sensor mountings can only be attached within the highlighted area due to the asymmetry of the internal magnets.

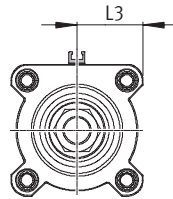
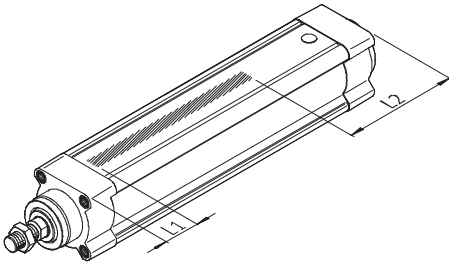

The proximity sensors may not switch reliably if they are mounted outside of this area.

The overall length of the sensor rail SAMH corresponds to the length of the sensing range plus approx. 10 mm adjustment range on either side for the proximity sensors.





Size	L1	L2	L3
63	40	129	37
80	40	156	46
100	46	176	54.5

Ordering data – Sensor mounting for T-slot

	Brief description	Length [mm]	Part No.	Type
Sensor rail				
	For proximity sensor SME/SMT-8	50	1600093	SAMH-N8-SR-50
		100	1600118	SAMH-N8-SR-100
Mounting kit				
	For proximity sensor SME/SMT-8	35	525565	CRSMB-8-32/100



Ordering data – Proximity sensors for T-slot, magneto-resistive

Technical data → Internet: smt

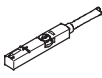

	Type of mounting	Switch output	Electrical connection	Cable length [m]	Part No.	Type
N/O contact						
	Insertable in the slot from above, flush with cylinder profile, short design	PNP	Cable, 3-wire	2.5	574335	SMT-8M-A-PS-24V-E-2,5-OE
			Plug M8x1, 3-pin	0.3	574334	SMT-8M-A-PS-24V-E-0,3-M8D
			Plug M12x1, 3-pin	0.3	574337	SMT-8M-A-PS-24V-E-0,3-M12
		NPN	Cable, 3-wire	2.5	574338	SMT-8M-A-NS-24V-E-2,5-OE
			Plug M8x1, 3-pin	0.3	574339	SMT-8M-A-NS-24V-E-0,3-M8D
N/C contact						
	Insertable in the slot from above, flush with cylinder profile, short design	PNP	Cable, 3-wire	7.5	574340	SMT-8M-A-PO-24V-E-7,5-OE

Electric cylinders ESBF, with spindle drive

Accessories

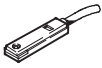
Ordering data – Proximity sensor for T-slot, magnetic reed						Technical data → Internet: sme	
	Type of mounting	Switching output	Electrical connection	Cable length [m]	Part No.	Type	
N/O contact							
	Insertable in the slot from above, flush with the cylinder profile	Contacting	Cable, 3-wire	2.5	543862	SME-8M-DS-24V-K-2,5-OE	
				5.0	543863	SME-8M-DS-24V-K-5,0-OE	
			Cable, 2-wire	2.5	543872	SME-8M-ZS-24V-K-2,5-OE	
				0.3	543861	SME-8M-DS-24V-K-0,3-M8D	
N/C contact							
	Insertable in the slot lengthwise, flush with the cylinder profile	Contacting	Cable, 3-wire	7.5	160251	SME-8-O-K-LED-24	

Ordering data – Proximity sensor, magneto-resistive CRSMT					Technical data → Internet: crsmt	
	Switching output	Electrical connection	Cable length [m]	Part No.	Type	
	N/O contact					
	PNP	3-wire	2.5	525563	CRSMT-8-PS-K2,5-LED-24	
			5.0	525564	CRSMT-8-PS-K5-LED-24	

Ordering data – Connecting cables					Technical data → Internet: nebu	
	Electrical connection, left	Electrical connection, right	Cable length [m]	Part No.	Type	
	Straight socket, M8x1, 3-pin	Cable, open end, 3-wire	2.5	541333	NEBU-M8G3-K-2.5-LE3	
			5	541334	NEBU-M8G3-K-5-LE3	
	Straight socket, M12x1, 5-pin	Cable, open end, 3-wire	2.5	541363	NEBU-M12G5-K-2.5-LE3	
			5	541364	NEBU-M12G5-K-5-LE3	
	Angled socket, M8x1, 3-pin	Cable, open end, 3-wire	2.5	541338	NEBU-M8W3-K-2.5-LE3	
			5	541341	NEBU-M8W3-K-5-LE3	
	Angled socket, M12x1, 5-pin	Cable, open end, 3-wire	2.5	541367	NEBU-M12W5-K-2.5-LE3	
			5	541370	NEBU-M12W5-K-5-LE3	

Ordering data – Plug screws, corrosion-resistant							
	For Ø	Material	CRC ¹⁾	Weight [g]	Part No.	Type	PU ²⁾
	63	High-alloy steel	3	14	650121	DAMD-PS-M8-16-R1	4
	80, 100		3	23	1355026	DAMD-PS-M10-16-R1	

- 1) Corrosion resistance class 3 according to Festo standard 940 070
Components subject to high corrosion stress. Externally visible parts with primarily functional surface requirements which are in direct contact with a normal industrial environment or media such as solvents and cleaning agents.
- 2) Packaging unit

Product Range and Company Overview

A Complete Suite of Automation Services

Our experienced engineers provide complete support at every stage of your development process, including: conceptualization, analysis, engineering, design, assembly, documentation, validation, and production.



Custom Automation Components
Complete custom engineered solutions



Custom Control Cabinets
Comprehensive engineering support and on-site services



Complete Systems
Shipment, stocking and storage services

The Broadest Range of Automation Components

With a comprehensive line of more than 30,000 automation components, Festo is capable of solving the most complex automation requirements.



Electromechanical
Electromechanical actuators, motors, controllers & drives



Pneumatics
Pneumatic linear and rotary actuators, valves, and air supply



PLCs and I/O Devices
PLC's, operator interfaces, sensors and I/O devices

Supporting Advanced Automation... As No One Else Can!

Festo is a leading global manufacturer of pneumatic and electromechanical systems, components and controls for industrial automation, with more than 12,000 employees in 56 national headquarters serving more than 180 countries. For more than 80 years, Festo has continuously elevated the state of manufacturing with innovations and optimized motion control solutions that deliver higher performing, more profitable automated manufacturing and processing equipment. Our dedication to the advancement of automation extends beyond technology to the education and development of current and future automation and robotics designers with simulation tools, teaching programs, and on-site services.

Quality Assurance, ISO 9001 and ISO 14001 Certifications

Festo Corporation is committed to supply all Festo products and services that will meet or exceed our customers' requirements in product quality, delivery, customer service and satisfaction.

To meet this commitment, we strive to ensure a consistent, integrated, and systematic approach to management that will meet or exceed the requirements of the ISO 9001 standard for Quality Management and the ISO 14001 standard for Environmental Management.



© Copyright 2008, Festo Corporation. While every effort is made to ensure that all dimensions and specifications are correct, Festo cannot guarantee that publications are completely free of any error, in particular typing or printing errors. Accordingly, Festo cannot be held responsible for the same. For Liability and Warranty conditions, refer to our "Terms and Conditions of Sale", available from your local Festo office. All rights reserved. No part of this publication may be reproduced, distributed, or transmitted in any form or by any means, electronic, mechanical, photocopying or otherwise, without the prior written permission of Festo. All technical data subject to change according to technical update.



Printed on recycled paper at New Horizon Graphic, Inc., FSC certified as an environmentally friendly printing plant.

Festo North America

Festo Regional Contact Center

5300 Explorer Drive
Mississauga, Ontario L4W 5G4
Canada

USA Customers:

For ordering assistance,

Call: 1.800.99.FESTO (1.800.993.3786)

Fax: 1.800.96.FESTO (1.800.963.3786)

Email: customer.service@us.festo.com

For technical support,

Call: 1.866.GO.FESTO (1.866.463.3786)

Fax: 1.800.96.FESTO (1.800.963.3786)

Email: product.support@us.festo.com

Canadian Customers:

Call: 1.877.GO.FESTO (1.877.463.3786)

Fax: 1.877.FX.FESTO (1.877.393.3786)

Email: festo.canada@ca.festo.com

USA Headquarters

Festo Corporation
395 Moreland Road
P.O. Box 18023
Hauppauge, NY 11788, USA
www.festo.com/us

USA Sales Offices

Appleton

North 922 Tower View Drive, Suite N
Greenville, WI 54942, USA

Boston

120 Presidential Way, Suite 330
Woburn, MA 01801, USA

Chicago

1441 East Business Center Drive
Mt. Prospect, IL 60056, USA

Dallas

1825 Lakeway Drive, Suite 600
Lewisville, TX 75057, USA

Detroit – Automotive Engineering Center

2601 Cambridge Court, Suite 320
Auburn Hills, MI 48326, USA

New York

395 Moreland Road
Hauppauge, NY 11788, USA

Silicon Valley

4935 Southfront Road, Suite F
Livermore, CA 94550, USA

United States



USA Headquarters, East: Festo Corp., 395 Moreland Road, Hauppauge, NY 11788

Phone: 1.631.435.0800; Fax: 1.631.435.8026;

Email: info@festo-usa.com

www.festo.com/us

Canada



Headquarters: Festo Inc., 5300 Explorer Drive, Mississauga, Ontario L4W 5G4

Phone: 1.905.624.9000; Fax: 1.905.624.9001;

Email: festo.canada@ca.festo.com

www.festo.ca

Mexico



Headquarters: Festo Pneumatic, S.A., Av. Ceylán 3, Col. Tequesquahuac,
54020 Tlalneantla, Edo. de México

Phone: 011 52 [55] 53 21 66 00; Fax: 011 52 [55] 53 21 66 65;

Email: festo.mexico@mx.festo.com

www.festo.com/mx

Central USA

Festo Corporation
1441 East Business
Center Drive
Mt. Prospect, IL 60056, USA
Phone: 1.847.759.2600
Fax: 1.847.768.9480



Western USA

Festo Corporation
4935 Southfront Road,
Suite F
Livermore, CA 94550, USA
Phone: 1.925.371.1099
Fax: 1.925.245.1286



Festo Worldwide

Argentina Australia Austria Belarus Belgium Brazil Bulgaria Canada Chile China Colombia Croatia Czech Republic Denmark
Estonia Finland France Germany Great Britain Greece Hong Kong Hungary India Indonesia Iran Ireland Israel Italy Japan Latvia
Lithuania Malaysia Mexico Netherlands New Zealand Norway Peru Philippines Poland Romania Russia Serbia Singapore
Slovakia Slovenia South Africa South Korea Spain Sweden Switzerland Taiwan Thailand Turkey Ukraine United States Venezuela

www.festo.com