

Electric slides EGSK/EGSP

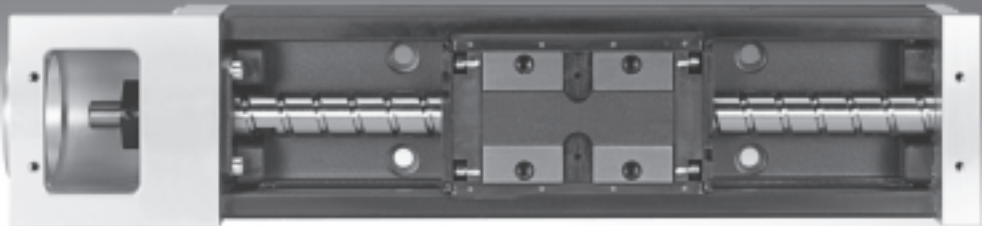

# Electromechanical drives

Selection aid



## Overview of toothed belt and spindle axes

Toothed belt axes	Spindle axes	Coordinate system
<ul style="list-style-type: none"> <li>• Speeds of up to 10 m/s</li> <li>• Acceleration of up to 50 m/s<sup>2</sup></li> <li>• Repetition accuracy of up to +0.08 mm</li> <li>• Strokes of up to 8,500 mm (longer strokes on request)</li> <li>• Flexible motor mounting</li> </ul>	<ul style="list-style-type: none"> <li>• Speeds of up to 2 m/s</li> <li>• Acceleration of up to 20 m/s<sup>2</sup></li> <li>• Repetition accuracy of up to +0.003 mm</li> <li>• Strokes of up to 3,000 mm</li> </ul>	

### Toothed belt axes

Type	$F_x$ [N]	$v$ [m/s]	$M_x$ [Nm]	$M_y$ [Nm]	$M_z$ [Nm]	Properties
------	--------------	--------------	---------------	---------------	---------------	------------

Heavy-duty recirculating ball bearing guide						
EGC-HD-TB						
	450	3	140	275	275	<ul style="list-style-type: none"> <li>• Flat drive unit with rigid, closed profile</li> <li>• Precision, resilient DUO guide rail</li> <li>• Ideal as a basic axis for linear gantries and cantilever axes</li> </ul>
	1,000	5	300	500	500	
	1,800	5	900	1,450	1,450	

Recirculating ball bearing guide						
EGC-TB-KF						
	50	3	3.5	10	10	<ul style="list-style-type: none"> <li>• Rigid, closed profile</li> <li>• Precision, resilient guide rail</li> <li>• Small drive pinions reduce necessary driving torque</li> <li>• Space-saving position sensing</li> </ul>
	100	5	16	132	132	
	350	5	36	228	228	
	800	5	144	680	680	
	2,500	5	529	1,820	1,820	
ELGR-TB						
	50	3	2.5	20	20	<ul style="list-style-type: none"> <li>• Cost-optimised rod guide</li> <li>• Ready-to-install unit</li> <li>• Resilient ball bearings for dynamic operation</li> </ul>
	100	3	5	40	40	
	350	3	15	124	124	

Roller bearing guide						
ELGA-TB-RF						
	350	10	11	40	40	<ul style="list-style-type: none"> <li>• Sturdy roller bearing guide</li> <li>• Guide and toothed belt protected by cover strip</li> <li>• Speeds of up to 10 m/s</li> <li>• Lower weight than axes with guide rails</li> </ul>
	800	10	30	180	180	
	1 300	10	100	640	640	

Plain-bearing guide						
ELGA-TB-G						
	350	5	5	30	10	<ul style="list-style-type: none"> <li>• Guide and toothed belt protected by cover strip</li> <li>• For simple handling tasks</li> <li>• As an actuator for external guides</li> <li>• Insensitive to harsh environmental conditions</li> </ul>
	800	5	10	60	20	
	1,300	5	120	120	40	
ELGR-TB-GF						
	50	1	1	10	10	<ul style="list-style-type: none"> <li>• Cost-optimised rod guide</li> <li>• Ready-to-install unit</li> <li>• Heavy-duty plain bearings for use in harsh environmental conditions</li> </ul>
	100	1	2.5	20	20	
	350	1	1	40	40	

# Electromechanical drives

Selection aid

## Overview of toothed belt and spindle axes

### Toothed belt axes

- Speeds of up to 10 m/s
- Acceleration of up to 50 m/s<sup>2</sup>
- Repetition accuracy of up to +0.08 mm
- Strokes of up to 8,500 mm (longer strokes on request)
- Flexible motor mounting

### Spindle axes

- Speeds of up to 2 m/s
- Acceleration of up to 20 m/s<sup>2</sup>
- Repetition accuracy of up to +0.003 mm
- Strokes of up to 3,000 mm

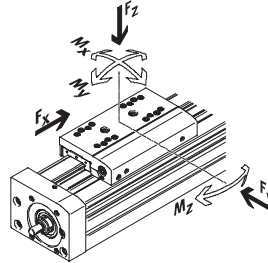

## Spindle axes

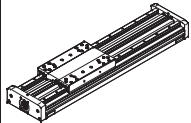
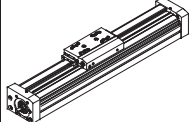
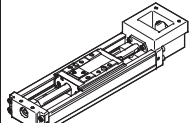
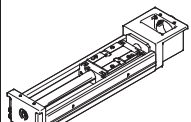
Type	$F_x$ [N]	$v$ [m/s]	$M_x$ [Nm]	$M_y$ [Nm]	$M_z$ [Nm]	Properties
<b>Heavy-duty recirculating ball bearing guide</b>						
<b>EGC-HD-BS</b>						
	300 600 1,300	0.5 1.0 1.5	140 300 900	275 500 1,450	275 500 1,450	<ul style="list-style-type: none"> <li>• Flat drive unit with rigid, closed profile</li> <li>• Precision, resilient DUO guide rail</li> <li>• Ideal as a basic axis for linear gantries and cantilever axes</li> </ul>
<b>Recirculating ball bearing guide</b>						
<b>EGC-BS-KF</b>						
	300 600 1,300 3,000	0.5 1.0 1.5 2.0	16 36 144 529	132 228 680 1,820	132 228 680 1,820	<ul style="list-style-type: none"> <li>• Rigid, closed profile</li> <li>• Precision, resilient guide rail</li> <li>• For extremely high requirements for speed, acceleration and torque resistance</li> <li>• Space-saving position sensing</li> </ul>
<b>EGSK</b>						
	57 133 184 239 392	0.33 1.10 0.83 1.10 1.48	13 28.7 60 79.5 231	3.7 9.2 20.4 26 77.3	3.7 9.2 20.4 26 77.3	<ul style="list-style-type: none"> <li>• Spindle axes with maximum precision, compactness and rigidity</li> <li>• Recirculating ball bearing guide and ball screw without caged ball bearings</li> <li>• Standard designs in stock</li> </ul>
<b>EGSP</b>						
	112 212 466 460	0.6 0.6 2.0 2.0	36.3 81.5 90.3 258	12.5 31.6 32.1 94	12.5 31.6 32.1 94	<ul style="list-style-type: none"> <li>• Spindle axes with maximum precision, compactness and rigidity</li> <li>• Recirculating ball bearing guide with caged ball bearings</li> <li>• Ball screw sizes 33, 46 with caged ball bearings</li> </ul>

# Electric slides EGSK/EGSP

Key features



## At a glance

### Precision embedded in steel

The new generation of electric slide axes EGSK and EGSP impresses with its precision, repetition accuracy, compactness and rigidity.

The two axis series form a complete range with a uniform design, long service life and standardised mounting interfaces. The U-shaped steel housing serves simultaneously as a guide rail. The slide combines

linear guide elements and the spindle nuts of the ball screw in one component, thus avoiding the accumulation of production tolerances.

Both series come in three accuracy classes with the option of an additional slide (series 33 and 46 are also available in a short-slide design).

### Electric slide EGSK

- Recirculating ball bearing guide and ball screw without caged balls
- Standard designs available ex-stock

### Electric slide EGSP

- Recirculating ball bearing guide with caged balls
- Size 33, 46 features a ball screw with caged balls
- Low-maintenance
- Uniform operating behaviour with very low noise levels

## Linear guide with caged balls

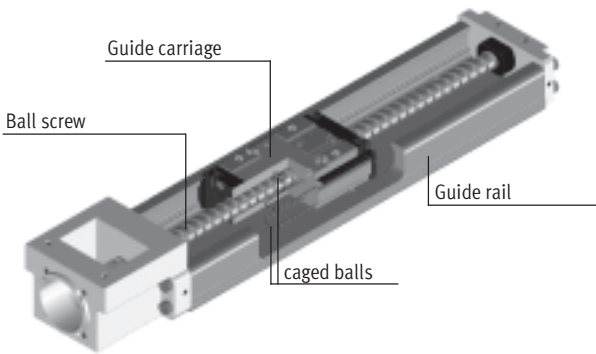

The linear guide features four rows of balls circulating within the guide carriage. In the loaded area, the balls run between the honed grooves of the guide carriage and guide rail until they are returned by means of the reversers in the end plates and the return channels. The very rigid design of the guide carriage enables precision linear movements to be

executed with impressive dynamism. The four rows of balls are arranged at a contact angle of 45°, giving the guide carriage the same basic load ratings in both radial coordinate directions. This type of guide can therefore be used in any mounting position for a wide range of load directions.

## Axis characteristics

The specifications shown in the table are maximum values.

The precise values for each of the variants can be found in the relevant technical data section.

Design	Size	Working stroke [mm]	Speed [m/s]	Repetition accuracy [µm]	Feed force [N]	Guide characteristics				
						Forces and torques				
						F <sub>y</sub> [N]	F <sub>z</sub> [N]	M <sub>x</sub> [Nm]	M <sub>y</sub> [Nm]	M <sub>z</sub> [Nm]
<b>Electric slide EGSK</b>						<b>→ 8</b>				
	15	25 ... 100	0.33	±3	57	1,185	1,185	13	3.7	3.7
	20	25 ... 125	1.10	±3	133	2,204	2,204	28.7	9.2	9.2
	26	50 ... 200	0.83	±3	184	3,528	3,528	60	20.4	20.4
	33	100 ... 630	1.10	±3	239	3,920	3,920	79.5	26	26
	46	200 ... 840	1.48	±3	392	7,809	7,809	231	77.3	77.3
<b>Electric slide EGSP</b>						<b>→ 31</b>				
	20	25 ... 125	0.6	±3	112	2,929	2,929	36.3	12.5	12.5
	26	50 ... 200	0.6	±3	212	5,028	5,028	81.5	31.6	31.6
	33	100 ... 630	2	±3	466	4,559	4,559	90.3	32.1	32.1
	46	200 ... 840	2	±3	460	8,935	8,935	258	94	94

# Electric slides EGSK/EGSP

Key features

FESTO

Complete system comprising electric slide, motor, motor controller and motor mounting kit

Electric slide with recirculating ball bearing guide



## Motor

→ 42



- 1 Servo motor EMMS-AS
- 2 Stepper motor EMMS-ST

### Note

A range of specially matched complete solutions is available for the electric slides EGSK, EGSP and the motors.

## Motor controller

Technical data → Internet: motor controller



- 1 Servo motor controller CMMP-AS, CMMS-AS
- 2 Stepper motor controller CMMS-ST

## Motor mounting kit

→ 42

Axial kit



Kit comprising:

- Motor flange
- Coupling
- Screws

# Electric slides EGSK/EGSP

Peripherals overview

FESTO

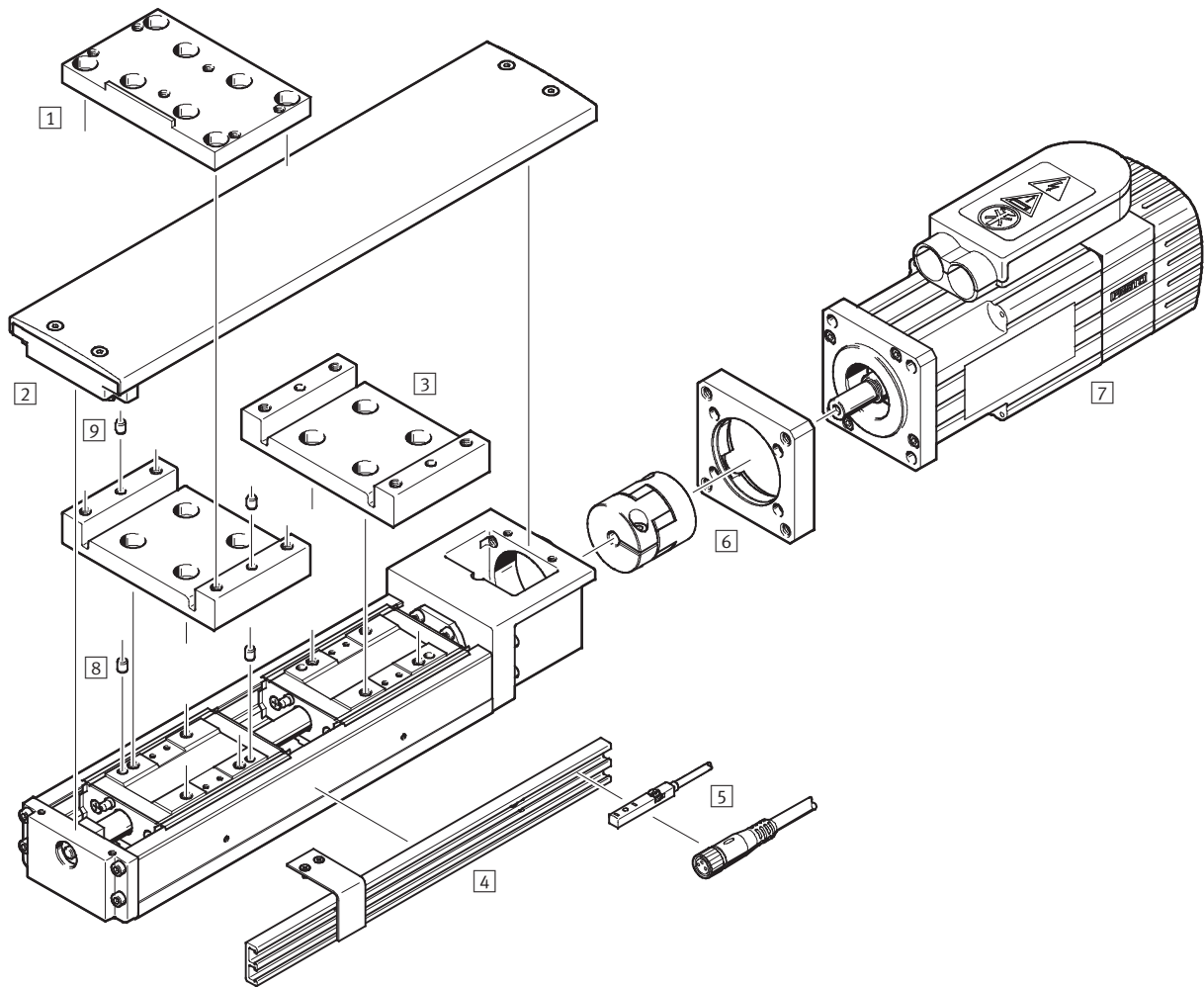

# Electric slides EGSK/EGSP

Peripherals overview

Accessories		
Type	Brief description	➔ Page/Internet
1 Cross connecting kit EHAM-S1	For mounting an assembly axis EGSK/EGSP at right angles on the slide of a basic axis EGSK/EGSP. The assembly axis is one size smaller than the respective basic axis.	54
2 Covering kit EASC-S1	For covering the axis profile that is open at the top. The kit includes a slide adapter EASA-S1.	56
3 Slide adapter EASA-S1	Required to mount the effective load in combination with the covering kit for axis variants with additional slide.	55
4 Sensor strip EAPR-S1-S	<ul style="list-style-type: none"> <li>• For mounting the inductive proximity sensor SIES-8M on the electric slide.</li> <li>• Switching lugs are included in the scope of delivery.</li> </ul>	59
5 Proximity sensor SIES-8M	Inductive proximity sensor, for T-slot.	61
6 Axial kit EAMM-A	For axial motor mounting (comprising: coupling and motor flange).	52
7 Motor EMMS	Motors specially matched to the axis, with or without brake.	52
8 Centring pin ZBS	For centring loads and attachments on the slide.	61
9 Centring pin ZBS	For centring loads and attachments on the slide adapter.	61

# Electric slides EGSK

Type codes

		EGSK	-	20	-	125	-	6P	-	H	-		-	Z
<b>Type</b>														
EGSK	Electric slide													
<b>Size</b>														
<b>Stroke [mm]</b>														
<b>Spindle pitch</b>														
<b>Accuracy</b>														
-	Standard													
H	High accuracy													
P	Precision design													
<b>Slide design</b>														
-	Standard slide													
S	Slide, short													
<b>Additional slide</b>														
-	No additional slide													
Z	Additional slide													



# Electric slides EGSK

Technical data

FESTO

Function

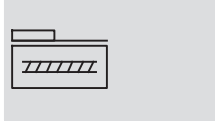

- N- Size  
15 ... 46
- T- Stroke length  
25 ... 840 mm



General technical data													
Size		15 <sup>2)</sup>		20		26		33		46			
Spindle pitch		1	2	1	6	2	6	6	10	10	20		
		Code <sup>1)</sup>											
Constructional design		Electromechanical linear axis with recirculating ball bearing spindle											
Guide		Recirculating ball bearing guide											
Installation position		Any											
Type of mounting for effective load		Female thread											
		Centring sleeve				Locating pin							
Working stroke <sup>3)</sup>	-	[mm]		25 ... 100		25 ... 125		50 ... 200		100 ... 600		200 ... 800	
	S	[mm]		-		-		-		130 ... 630		240 ... 840	
Max. feed force	-/H <sup>4)</sup>	[N]		36	19	69	72	116	116	150	148	264	192
F <sub>x,max</sub>	P <sup>5)</sup>	[N]		57	31	110	133	184	184	239	183	392	343
Max. driving torque	-/H <sup>4)</sup>	[Ncm]		0.6	0.6	1.1	6.9	3.7	11	14	24	42	61
M <sub>Driving,max</sub>	P <sup>5)</sup>	[Ncm]		0.9	1.0	1.8	13	5.9	18	23	29	62	109
No-load torque	-/H	[Ncm]		0.4	0.4	0.5	0.5	1.5	1.5	7	7	10	10
M <sub>No-load</sub>	P	[Ncm]		0.8	0.8	1.2	1.2	4.0	4.0	15	15	17	17
Max. rotational speed <sup>6)</sup>		[1/min]		9,600	9,900	11,400	7,900	8,400	5,900	4,700	4,700	3,100	3,100
Max. speed <sup>6)</sup>	-/H	[m/s]		0.16	0.33	0.19	0.79	0.28	0.59	0.47	0.79	0.52	1.05
	P	[m/s]		0.16	0.33	0.19	1.10	0.28	0.83	0.66	1.10	0.74	1.48
Max. acceleration		[m/s <sup>2</sup> ]		10		10		10		20		20	
Homing		Inductive proximity sensor SIES-8M											

- 1) Variant code → 8
- 2) Size 15 only comes in the accuracy classes H and P
- 3) Maximum travel distance → 17  
In combination with an additional slide, the working stroke is reduced by the length of the additional slide and the distance between the two slides
- 4) Loads are based on a service life specification of  $5 \times 10^8$  rotations
- 5) Loads are based on a service life specification of  $1.25 \times 10^8$  rotations
- 6) Reduced speeds with sizes 33 and 46 with long strokes → 11

Operating and environmental conditions		
Ambient temperature	[°C]	0 ... +40
Relative air humidity	[%]	0 ... 95 (non-condensing)

Weight [kg]											
Size		15		20		26		33		46	
		Code <sup>1)</sup>									
Basic weight with 0 mm stroke <sup>2)</sup>	-	0.16		0.38		0.78		1.38		5.17	
	S	-		-		-		1.28		4.77	
Additional weight per 100 mm stroke	-	0.12		0.27		0.42		0.63		1.27	
Moving load	-	0.04		0.07		0.15		0.31		0.91	
	S	-		-		-		0.17		0.57	
Additional slide Z	-	0.04		0.07		0.15		0.31		0.91	
	S	-		-		-		0.17		0.57	

- 1) Variant code → 8
- 2) Including slide, without additional slide

# Electric slides EGSK

Technical data

FESTO

Accuracy data [µm]			15	20	26	33	46
Size	Stroke	Code <sup>1)</sup>					
Repetition accuracy <sup>2)</sup>		–	–	±10	±10	±10	±10
		H	±4	±5	±5	±5	±5
		P	±3	±3	±3	±3	±3
Operating parallelism	25 ... 340	H	20	25	25	25	35
	400 ... 540	H	–	–	–	35	35
	600 ... 640	H	–	–	–	40	40
	800 ... 840	H	–	–	–	–	50
	25 ... 340	P	10	10	10	10	15
	400 ... 540	P	–	–	–	15	15
Max. reversing play		–	–	20	20	20	20
		H	10	10	10	20	20
		P	2	3	3	3	3

1) Variant code → 8

2) The repetition accuracy that can be achieved with a motor/axis system is also influenced by the angle resolution of the motor and the chosen control parameters. The specified repetition accuracy cannot, therefore, be achieved with all motors.

## Materials

Sectional view

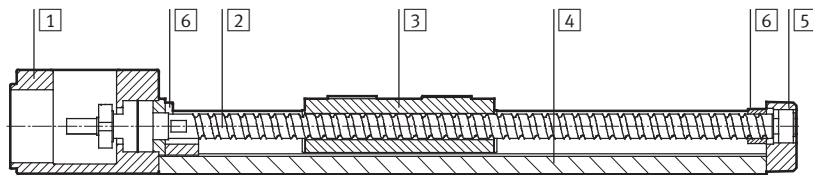

Electric slide	
1 Drive cover	Die-cast aluminium, coated
2 Spindle	Steel
3 Slide	Steel
4 Profile	High-alloy steel
5 End cap	Die-cast aluminium, coated
6 Buffer	Ethylene vinyl acetate copolymer
Note on materials	RoHS-compliant Contains PWIS (paint-wetting impairment substances)

Mass moment of inertia											
Size		15		20		26		33		46	
Spindle pitch		1	2	1	6	2	6	6	10	10	20
	Code <sup>1)</sup>										
J <sub>0</sub>	[kg mm <sup>2</sup> ]	0.030	0.033	0.087	0.143	0.355	0.479	1.15	1.65	8.43	15.3
	S [kg mm <sup>2</sup> ]	–	–	–	–	–	–	0.791	1.07	6.01	10.3
J <sub>S</sub> per 100 mm stroke	[kg mm <sup>2</sup> /100 mm]	0.048		0.099		0.314		0.766		3.877	
J <sub>L</sub> per kg effective load	[kg mm <sup>2</sup> /kg]	0.03	0.10	0.03	0.91	0.10	0.91	0.91	2.53	2.53	10.13
J <sub>W</sub> per additional slide	[kg mm <sup>2</sup> ]	0.001	0.004	0.002	0.058	0.016	0.14	0.28	0.79	2.31	9.22
	S [kg mm <sup>2</sup> ]	–	–	–	–	–	–	0.16	0.43	1.44	5.78

1) Variant code → 8

The mass moment of inertia J<sub>A</sub> of the entire axis is calculated as follows:

$$J_A = J_0 + J_W + J_S \times \text{working stroke} + J_L \times m_{\text{Effective load}}$$

# Electric slides EGSK

Technical data



## Speed v, rotational speed n as a function of working stroke l

EGSK-33-...-6P

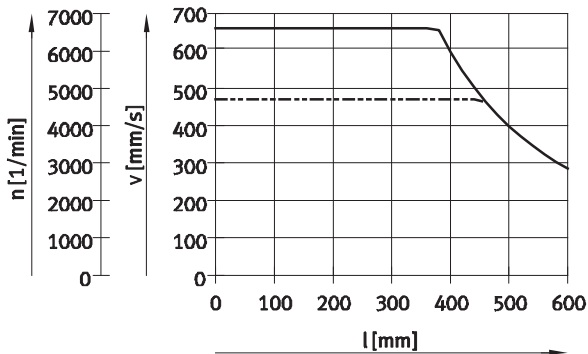

— EGSK-33-...-6P-P  
 - - - EGSK-33-...-6P, EGSK-33-...-6P-H

EGSK-33-...-10P

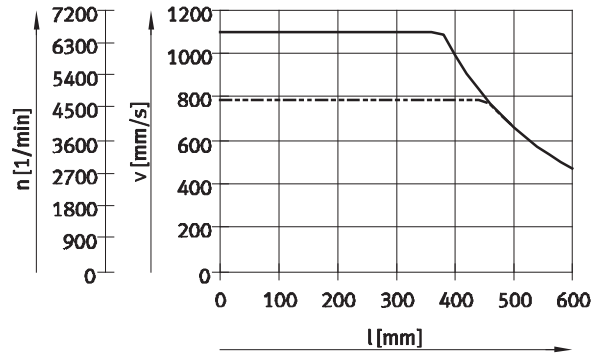

— EGSK-33-...-10P-P  
 - - - EGSK-33-...-10P, EGSK-33-...-10P-H

EGSK-46-...-10P

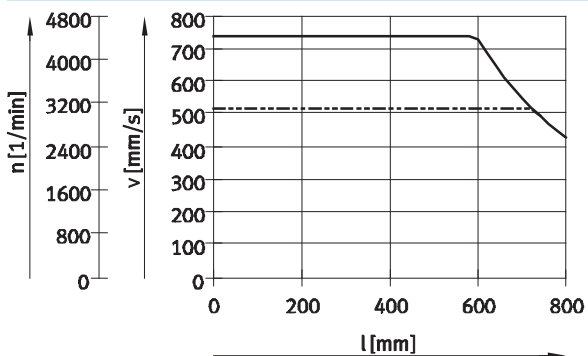

— EGSK-46-...-10P-P  
 - - - EGSK-46-...-10P, EGSK-46-...-10P-H

EGSK-46-...-20P

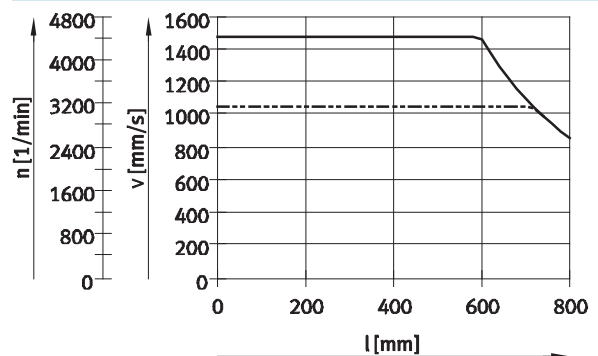

— EGSK-46-...-20P-P  
 - - - EGSK-46-...-20P, EGSK-46-...-20P-H

## 2nd moment of area

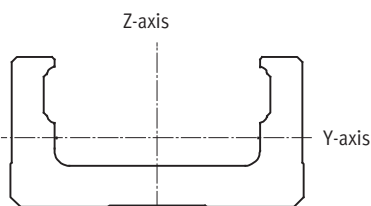

Size		15	20	26	33	46
ly	[mm <sup>4</sup> ]	908	6,100	17,000	62,000	240,000
lz	[mm <sup>4</sup> ]	14,200	62,000	150,000	380,000	1,500,000

# Electric slides EGSK

Technical data

FESTO

## Characteristic load values

The indicated forces and torques refer to the centre axis of the spindle.

The coordinate zero point is the point where the centre of the guide and the longitudinal centre of the slide intersect.

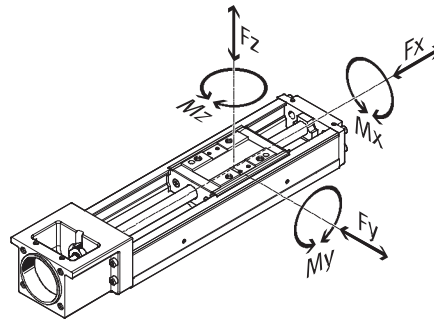

### Note

PositioningDrives  
sizing software  
www.festo.com

Permissible dynamic forces and torques <sup>1)</sup>			15 <sup>3)</sup>		20		26		33		46		
Size			1	2	1	6	2	6	6	10	10	20	
Spindle pitch	Code <sup>2)</sup>												
F <sub>y</sub> max., F <sub>z</sub> max.	-/H <sup>4)</sup>	-	[N]	747	593	1,389	764	2,223	1,541	2,469	2,083	4,919	3,904
	P <sup>5)</sup>	-	[N]	1,185	941	2,204	1,213	3,528	2,446	3,920	3,306	7,809	6,198
	-/H <sup>4)</sup>	S	[N]	-	-	-	-	-	-	1,043	880	2,514	1,995
	P <sup>5)</sup>	S	[N]	-	-	-	-	-	-	1,656	1,396	3,990	3,167
M <sub>x</sub> max.	-/H <sup>4)</sup>	-	[Nm]	8.2	6.5	18.1	9.9	37.8	26.2	50.1	42.2	145	115
	P <sup>5)</sup>	-	[Nm]	13	10.3	28.7	15.8	60	41.6	79.5	67.1	231	183
	-/H <sup>4)</sup>	S	[Nm]	-	-	-	-	-	-	21.2	17.8	74.4	59
	P <sup>5)</sup>	S	[Nm]	-	-	-	-	-	-	33.6	28.3	118	93.7
M <sub>y</sub> max., M <sub>z</sub> max.	-/H <sup>4)</sup>	-	[Nm]	2.3	1.9	5.8	3.2	12.9	8.9	16.4	13.8	48.7	38.7
	P <sup>5)</sup>	-	[Nm]	3.7	2.9	9.2	5.1	20.4	14.1	26	21.9	77.3	61.4
	-/H <sup>4)</sup>	S	[Nm]	-	-	-	-	-	-	3.8	3.2	13.6	10.8
	P <sup>5)</sup>	S	[Nm]	-	-	-	-	-	-	6	5	21.6	17.1

- 1) Calculated with a speed-dependent load factor  $f_w$  of 1.2
- 2) Variant code → 8
- 3) Size 15 only comes in the accuracy classes H and P
- 4) Loads are based on a service life specification of  $5 \times 10^8$  rotations and a load factor  $f_w$  of 1.2
- 5) Loads are based on a service life specification of  $1.25 \times 10^8$  rotations and a load factor  $f_w$  of 1.2

Basic load ratings			15 <sup>2)</sup>		20		26		33		46	
Size			1	2	1	6	2	6	6	10	10	20
Spindle pitch	Code <sup>1)</sup>											
Ball screw												
Static C <sub>0</sub> ball screw	-/H	[N]	660	410	1,170	1,450	4,020	3,510	4,900	2,840	6,760	7,150
	P	[N]	660	410	1,170	1,600	4,020	3,900	2,740	1,570	3,720	5,290
Dynamic C <sub>dyn</sub> ball screw	-/H <sup>3)</sup>	[N]	340	230	660	860	2,350	1,950	2,840	1,760	3,140	3,040
	P <sup>3)</sup>	[N]	340	230	660	1,060	2,350	2,390	2,250	1,370	2,940	3,430
Fixed bearing												
Static C <sub>0</sub> bearing		[N]	290		1,240		1,760		2,590		3,240	
Dynamic C <sub>dyn</sub> bearing <sup>3)</sup>		[N]	590		1,000		1,380		1,790		6,660	

- 1) Variant code → 8
- 2) Size 15 only comes in the accuracy classes H and P
- 3) Dynamic basic load ratings are based on a basic service life of  $10^6$  rotations

# Electric slides EGSK

Technical data

FESTO

Basic load ratings												
Size			15 <sup>2)</sup>		20		26		33		46	
Spindle pitch			1	2	1	6	2	6	6	10	10	20
Code <sup>1)</sup>												
Linear guide												
Static C <sub>0,guide</sub>	-	[N]	3,450	6,300	12,150	20,200	45,500					
	S	[N]	-	-	-	10,000	22,700					
Dynamic C <sub>dyn,guide</sub> <sup>3)</sup>	-	[N]	1,532	2,849	5,746	9,207	21,747					
	S	[N]	-	-	-	3,889	11,112					
Torque equivalence factors												
k <sub>x</sub>	-	[1/m]	90.9	76.9	58.8	49.3	33.8					
	S	[1/m]	-	-	-	49.3	33.8					
k <sub>y</sub> , k <sub>z</sub>	-	[1/m]	319.9	238.7	172.9	151	101					
	S	[1/m]	-	-	-	277.1	185					

1) Variant code → 8

2) Size 15 only comes in the accuracy classes H and P

3) Dynamic basic load ratings are based on a basic service life of 100 km

## Speed-dependent load factor f<sub>w</sub>

f<sub>w</sub> = 1.0 ... 1.2 (v ≤ 0.25 m/s)

f<sub>w</sub> = 1.2 ... 1.5 (0.25 m/s ≤ v ≤ 1.0 m/s)

f<sub>w</sub> = 1.5 ... 2.0 (1.0 m/s ≤ v ≤ 2.0 m/s)

f<sub>w</sub> = 2.0 ... 3.5 (v ≥ 2.0 m/s)

## Calculation of the maximum feed force F<sub>x</sub>

$$F_{x,max} = \frac{1}{f_w} \times \frac{\text{Min}[C_{dyn,KGT}; C_{dyn,bearing}]}{\sqrt[3]{\frac{l_{ref,rot}}{10^6}}}$$

## Calculation of the maximum forces F<sub>y/z</sub> and torques M<sub>x/y/z</sub>

$$F_{y/z,max} = \frac{1}{f_w} \times \frac{C_{dyn,guide}}{\sqrt[3]{\frac{l_{ref,km}}{100km}}}$$

$$M_{x/y/z,max} = \frac{1}{k_{x/y/z}} \times \frac{1}{f_w} \times \frac{C_{dyn,guide}}{\sqrt[3]{\frac{l_{ref,km}}{100km}}}$$

# Electric slides EGSK

Technical data

FESTO

## Calculation of the service life

Size	15		20		26		33		46		
Spindle pitch P	1	2	1	6	2	6	6	10	10	20	
	Code <sup>1)</sup>										
Reference service life in rotations, $L_{ref,rot}$	-/H	$5 \times 10^8$									
	P	$1.25 \times 10^8$									
Reference service life in kilometres, $L_{ref,km}$	-/H [km]	500	1,000	500	3,000	1,000	3,000	3,000	5,000	5,000	10,000
	P [km]	125	250	125	750	250	750	750	1,250	1,250	2,500

1) Variant code → 8

## 1 Representation of the loads

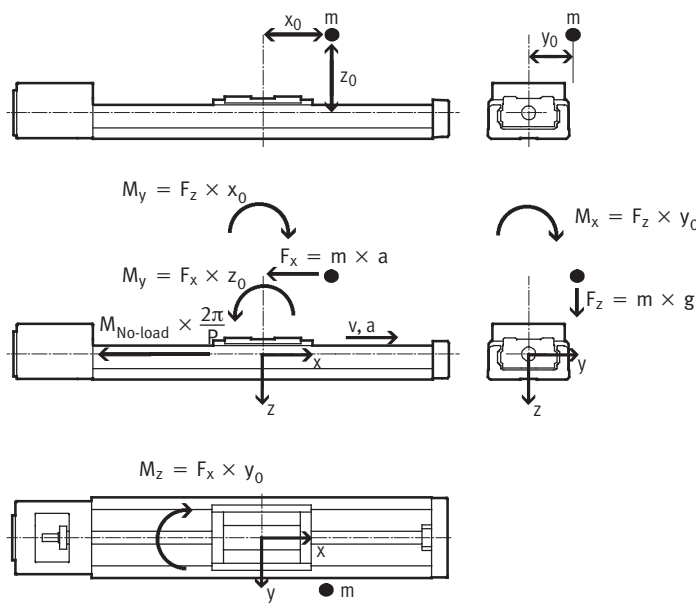

## 2 Determination of the loads over the travel cycle

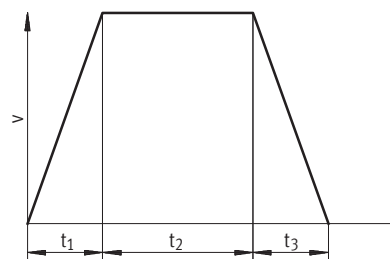

$$q_1 = \frac{t_1}{t_{tot}} \quad q_2 = \frac{t_2}{t_{tot}} \quad q_3 = \frac{t_3}{t_{tot}}$$

$$t_{tot} = t_1 + t_2 + t_3$$

v	Speed
t <sub>1</sub>	Acceleration time
t <sub>2</sub>	Constant travel time
t <sub>3</sub>	Deceleration time
q <sub>1/2/3</sub>	Relative time of the cycle phases
t <sub>tot</sub>	Cycle time

## Ball screw

For t<sub>1</sub>:  $F_{x1} = - (m \times a) - (M_{No-load} \times \frac{2\pi}{P})$

For t<sub>2</sub>:  $F_{x2} = - (M_{No-load} \times \frac{2\pi}{P})$

For t<sub>3</sub>:  $F_{x3} = m \times a - (M_{No-load} \times \frac{2\pi}{P})$

$$F_{x,dyn} = \sqrt[3]{q_1 \times |F_{x1}|^3 + q_2 \times |F_{x2}|^3 + q_3 \times |F_{x3}|^3}$$

F <sub>x1/2/3</sub>	Calculated force load per cycle phase
F <sub>x,dyn</sub>	Calculated average force load
m	Effective load (centre of gravity)
a	Acceleration
M <sub>No-load</sub>	No-load torque → 9
P	Spindle pitch → 9
q <sub>1/2/3</sub>	Relative time of the cycle phases

# Electric slides EGSK

Technical data

FESTO

2 Determination of the loads over the travel cycle		
Linear guide		
<p><b>For t<sub>1</sub>: a →, v →</b></p> <p><math>F_{y1} = 0</math></p> <p><math>F_{z1} = m \times g</math></p> <p><math>M_{x1} = F_z \times y_0 = m \times g \times y_0</math></p> <p><math>M_{y1} = -F_z \times x_0 + F_x \times z_0 = -m \times g \times x_0 + m \times a \times z_0</math></p> <p><math>M_{z1} = F_x \times y_0 = m \times a \times y_0</math></p>	<p><math>F_{y1/2/3}</math>, <math>F_{z1/2/3}</math></p> <p><math>M_{x1/2/3}</math>, <math>M_{y1/2/3}</math>, <math>M_{z1/2/3}</math></p> <p><math>F_{y/z,dyn}</math></p> <p><math>M_{x/y/z,dyn}</math></p> <p><math>m</math></p> <p><math>g</math></p> <p><math>a</math></p> <p><math>x_0, y_0, z_0</math></p>	<p>Calculated force load per cycle phase</p> <p>Calculated torque load per cycle phase</p> <p>Calculated average force load</p> <p>Calculated average torque load</p> <p>Effective load (centre of gravity)</p> <p>Gravitational acceleration</p> <p>Acceleration</p> <p>Distances between the centre of gravity of the effective load and the slide centre point</p> <p>Relative time of the cycle phases</p>
<p><b>For t<sub>2</sub>: a = 0, v →</b></p> <p><math>F_{y2} = 0</math></p> <p><math>F_{z2} = m \times g</math></p> <p><math>M_{x2} = F_z \times y_0 = m \times g \times y_0</math></p> <p><math>M_{y2} = -F_z \times x_0 = -m \times g \times x_0</math></p> <p><math>M_{z2} = 0</math></p>		
<p><b>For t<sub>3</sub>: a ←, v →</b></p> <p><math>F_{y3} = 0</math></p> <p><math>F_{z3} = m \times g</math></p> <p><math>M_{x3} = F_z \times y_0 = m \times g \times y_0</math></p> <p><math>M_{y3} = -F_z \times x_0 - F_x \times z_0 = -m \times g \times x_0 - m \times a \times z_0</math></p> <p><math>M_{z3} = -F_x \times y_0 = -m \times a \times y_0</math></p>		
<p><math>F_{y,dyn} = \sqrt[3]{q_1 \times  F_{y1} ^3 + q_2 \times  F_{y2} ^3 + q_3 \times  F_{y3} ^3}</math></p> <p><math>F_{z,dyn} = \sqrt[3]{q_1 \times  F_{z1} ^3 + q_2 \times  F_{z2} ^3 + q_3 \times  F_{z3} ^3}</math></p> <p><math>M_{x,dyn} = \sqrt[3]{q_1 \times  M_{x1} ^3 + q_2 \times  M_{x2} ^3 + q_3 \times  M_{x3} ^3}</math></p> <p><math>M_{y,dyn} = \sqrt[3]{q_1 \times  M_{y1} ^3 + q_2 \times  M_{y2} ^3 + q_3 \times  M_{y3} ^3}</math></p> <p><math>M_{z,dyn} = \sqrt[3]{q_1 \times  M_{z1} ^3 + q_2 \times  M_{z2} ^3 + q_3 \times  M_{z3} ^3}</math></p>		
3 Total load		
Ball screw		
<p><math>\frac{ F_{x,dyn} }{F_{x,max}} \leq f_v</math></p>	<p><math>F_{x,dyn}</math></p> <p><math>F_{x,max}</math></p> <p><math>f_v</math></p>	<p>Calculated average force load</p> <p>Max. permissible force load → 9</p> <p>Load comparison factor → 16</p>
Linear guide		
<p><math>\frac{ F_{y,dyn} }{F_{y,max}} + \frac{ F_{z,dyn} }{F_{z,max}} + \frac{ M_{x,dyn} }{M_{x,max}} + \frac{ M_{y,dyn} }{M_{y,max}} + \frac{ M_{z,dyn} }{M_{z,max}} \leq f_v</math></p>	<p><math>F_{y/z,dyn}</math></p> <p><math>F_{y/z,max}</math></p> <p><math>M_{x/y/z,dyn}</math></p> <p><math>M_{x/y/z,max}</math></p> <p><math>f_v</math></p>	<p>Calculated average force load</p> <p>Max. permissible force load → 12</p> <p>Calculated average torque load</p> <p>Max. permissible torque load → 12</p> <p>Load comparison factor → 16</p>

# Electric slides EGSK

Technical data



## 4 Determination of the load comparison factor $f_v$

$$f_v = \frac{1}{\sqrt[3]{q}} \quad \text{with} \quad q = \frac{L_{\text{calc,km}}}{L_{\text{ref,km}}} = \frac{L_{\text{calc,rot}}}{L_{\text{ref,rot}}}$$

for  $q = 1$ :

Calculated service life (here desired service life)  $L_{\text{calc,km}} = 1 \times$  reference service life  $L_{\text{ref,km}}$  gives  $f_v = 1$

for  $q \neq 1$ :

Calculated service life (here desired service life)  $L_{\text{calc,km}} = q \times$  reference service life  $L_{\text{ref,km}}$  read off ( $\rightarrow$  graph) or calculate  $f_v$

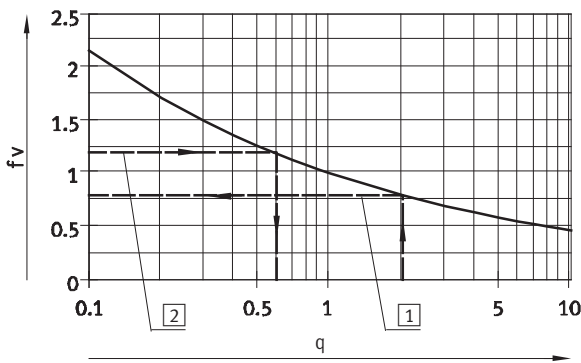

- 1  $\rightarrow$  Example 1
- 2  $\rightarrow$  Example 2

$f_v$	Load comparison factor
$q$	Quotient of desired service life divided by reference service life
$L_{\text{calc, km}}$	Calculated service life in km
$L_{\text{ref, km}}$	Reference service life in km $\rightarrow$ 14
$L_{\text{calc, rot}}$	Calculated service life in rotations
$L_{\text{ref, rot}}$	Reference service life in rotations $\rightarrow$ 14

## 5 Calculation examples

**Example 1:**

EGSK-26-...-2P-H-...

$L_{\text{ref,km}} = 1,000 \text{ km}$   
 $L_{\text{calc,km}} = 2,000 \text{ km}$

$q = \frac{2000\text{km}}{1000\text{km}} = 2.0$

$f_v = \frac{1}{\sqrt[3]{q}} = 0.79$

**Result:**  
 A desired service life of 200% of the reference service life means that the permissible total load must be 21% lower.

**Example 2:**

If the total load calculation gives a load comparison factor  $f_v$  of 1.2, the mathematical service life is only approx. 60% ( $x = 0.6 \rightarrow$  graph) of the reference service life.

$$q = \frac{1}{f_v^3} = 0.58$$

## 6 Static sizing

### Ball screw

$F_{x,\text{stat}} = \text{Max}[F_{x1}, F_{x2}, F_{x3}] \leq \frac{C_{0,\text{KGT}}}{f_s}$	$F_{x,\text{stat}}$	Maximum value of the calculated force load per cycle phase	$C_{0,\text{KGT}}$	Static basic load rating of ball screw $\rightarrow$ 12
	$F_{x1/2/3}$	Calculated force load per cycle phase	$f_s$	Safety factor against static overload $f_s = 1.0 \dots 3.0$

### Linear guide

$F_{y,\text{stat}} = \text{Max}[F_{y1}, F_{y2}, F_{y3}] \leq \frac{C_{0,\text{guide}}}{f_s}$	$F_{y/z,\text{stat}}$	Maximum value of the calculated force load per cycle phase	$M_{x1/2/3},$ $M_{y1/2/3},$ $M_{z1/2/3}$	Calculated torque load per cycle phase
$F_{z,\text{stat}} = \text{Max}[F_{z1}, F_{z2}, F_{z3}] \leq \frac{C_{0,\text{guide}}}{f_s}$	$M_{x/y/z,\text{stat}}$	Maximum value of the calculated torque load per cycle phase	$C_{0,\text{guide}}$	
$M_{x,\text{stat}} = \text{Max}[M_{x1}, M_{x2}, M_{x3}] \leq \frac{1}{k_x} \times \frac{C_{0,\text{guide}}}{f_s}$	$F_{y1/2/3},$ $F_{z1/2/3}$	Calculated force load per cycle phase	$k_{x/y/z}$	Torque equivalence factors $\rightarrow$ 13
$M_{y,\text{stat}} = \text{Max}[M_{y1}, M_{y2}, M_{y3}] \leq \frac{1}{k_y} \times \frac{C_{0,\text{guide}}}{f_s}$			$f_s$	Safety factor against static overload $f_s = 1.0 \dots 3.0$
$M_{z,\text{stat}} = \text{Max}[M_{z1}, M_{z2}, M_{z3}] \leq \frac{1}{k_z} \times \frac{C_{0,\text{guide}}}{f_s}$				



# Electric slides EGSK

Technical data

## Dimensions

Download CAD Data → [www.festo.com/us/cad](http://www.festo.com/us/cad)

EGSK-15

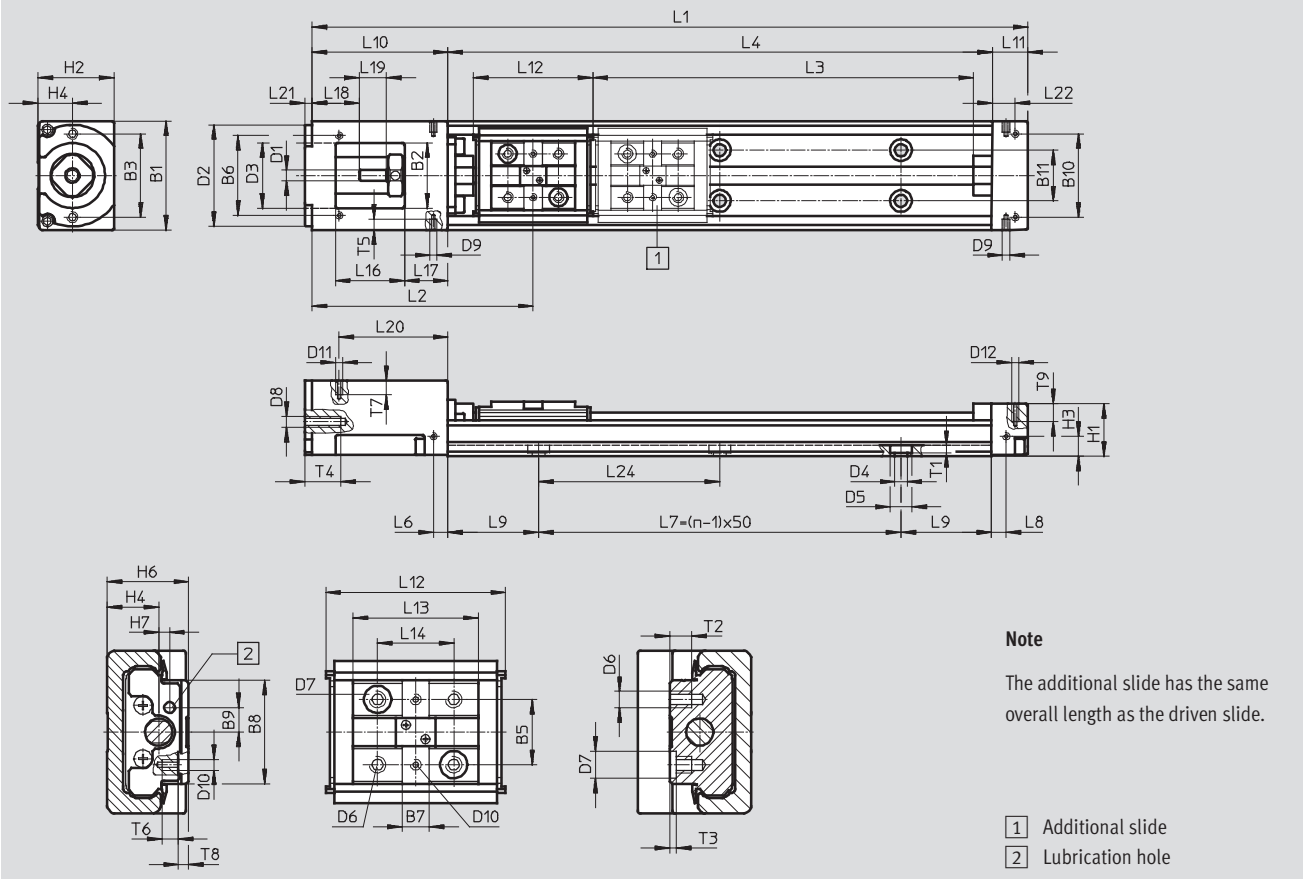

Size	Stroke	L1	L3 +4	L4	L7	L9	n
15	25	122.5	30	75	50	12.5	2
	50	147.5	55	100	50	25	2
	75	172.5	80	125	100	12.5	3
	100	197.5	105	150	100	25	3

Size	B1	B2	B3	B5	B6	B7	B8	B9	B11	B10	D1	D2	D3	D4	D5	D6	D7	D8
15	30	18	±0.1 23	±0.02 12	±0.1 22	5	19	4.5	14	±0.1 23	∅ h6 3	∅ g7 28	∅ 18	∅ 3.4	∅ 6	M3	∅ 5	M3

Size	D9	D10	D11	D12	H1	H2	H3	H4	H6	H7	L2	L6	L8	L10	L11	L12	L13	L14
15	M2	M2	M2	M2	14.5	20.9	5.5	9.5	15	2	60.3	4	4	37.5	10	33	23	±0.02 14

Size	L16	L17	L18	L19	L20	L21	L22	L24	T1	T2	T3	T4	T5	T6	T7	T8	T9
15	19	12	13	7.5	±0.1 30	2	±0.1 6.5	50	2	4	+0.1 1.2	10	3	3	4	1.9	5

# Electric slides EGSK

Technical data



## Dimensions

Download CAD Data → [www.festo.com/us/cad](http://www.festo.com/us/cad)

EGSK-20/26

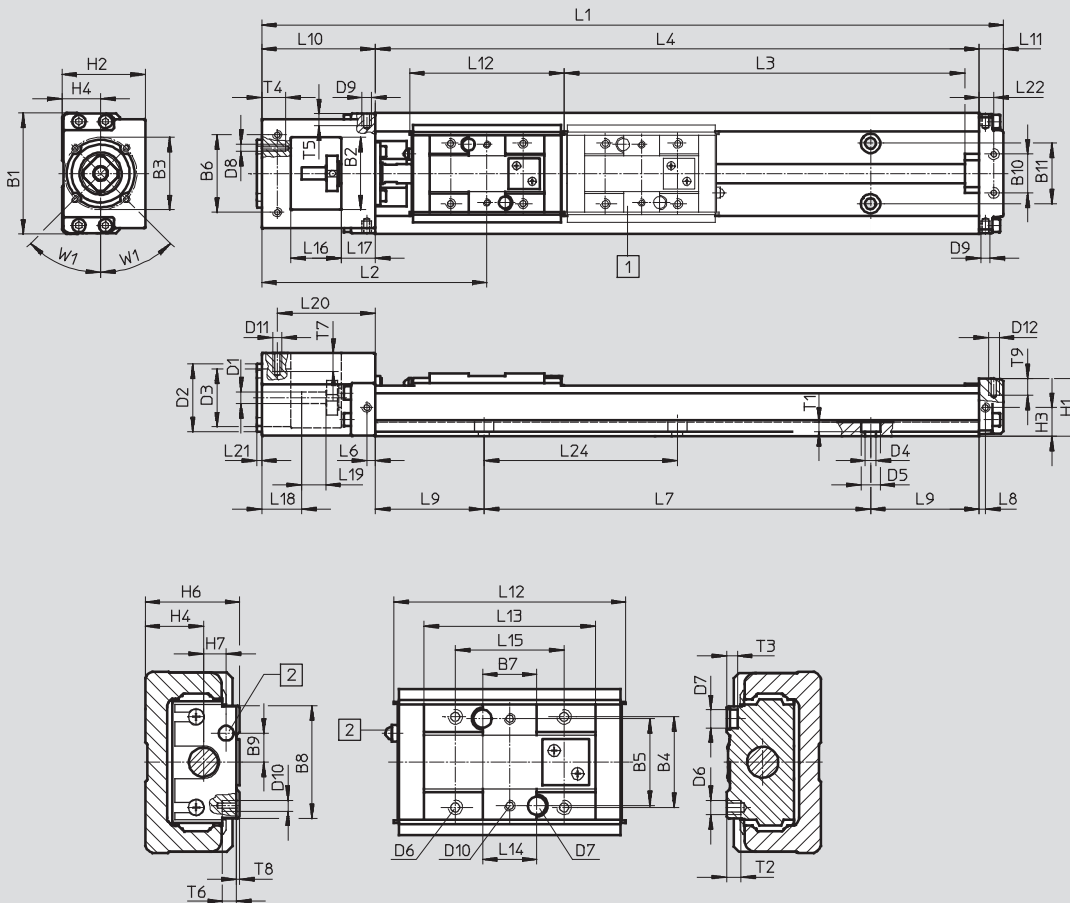

### Note

The additional slide has the same overall length as the driven slide.

- 1 Additional slide
- 2 Lubrication nipple

Size	Stroke	L1	L3 +4	L4	L7= (n-1)x60	L9	n	Size	Stroke	L1	L3 +4	L4	L7= (n-1)x80	L9	n
20	25	152	40	100	60	20	2	26	50	207	67	150	80	35	2
	75	202	90	150	120	15	3		100	257	117	200	160	20	3
	125	252	140	200	120	40	3		150	307	167	250	160	45	3
									200	357	217	300	240	30	4

# Electric slides EGSK

Technical data

Size	B1	B2	B3 ∅	B4	B5 ±0.02	B6 ±0.1	B7	B8	B9	B10 ±0.1	B11	D1 ∅ h7	D2 ∅ g7	D3 ∅
20	40	22	30	18	18	29	10	23	5	18	18	4	28	22
26	50	30	30	25	24	32	15	31	8	16	25	5	28	24

Size	D4 ∅	D5 ∅	D6	D7 ∅ H7	D8	D9	D10	D11	D12	H1	H2	H3	H4	H6
20	3.4	6.5	M3	2	M3	M2.6	M2	M2.5	M2.5	19	28	10	13	20
26	4.5	8	M4	5	M3	M2.6	M3	M2.5	M3	24	34.5	12	16	26

Size	H7	L2	L6	L8	L10	L11	L12	L13	L14 <sup>1)</sup> ±0.02	L15	L16	L17	L18	L19
20	3.4	72.5	3.5	2.5	42	10	46	33.2	10	20	18	12	16	8
26	6	91	3.5	2.5	47	10	64	47.4	15	30	21	14	16.5	10

Size	L20 ±0.1	L21	L22 ±0.1	L24	T1	T2	T3	T4	T5	T6	T7	T8	T9	W1
20	34.5	2	6.5	60	3	4.5	3	10	4	5	5	0.9	5	45°
26	40.5	2	6	80	4	6.5	3	10	4	6	5	0.9	6	45°

1) Distance between the locating holes

# Electric slides EGSK

Technical data

FESTO

## Dimensions

Download CAD Data → [www.festo.com/us/cad](http://www.festo.com/us/cad)

EGSK-33/46

EGSK-...-S

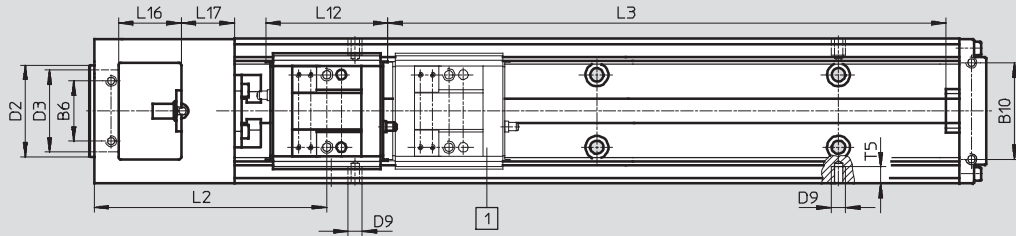

EGSK-...

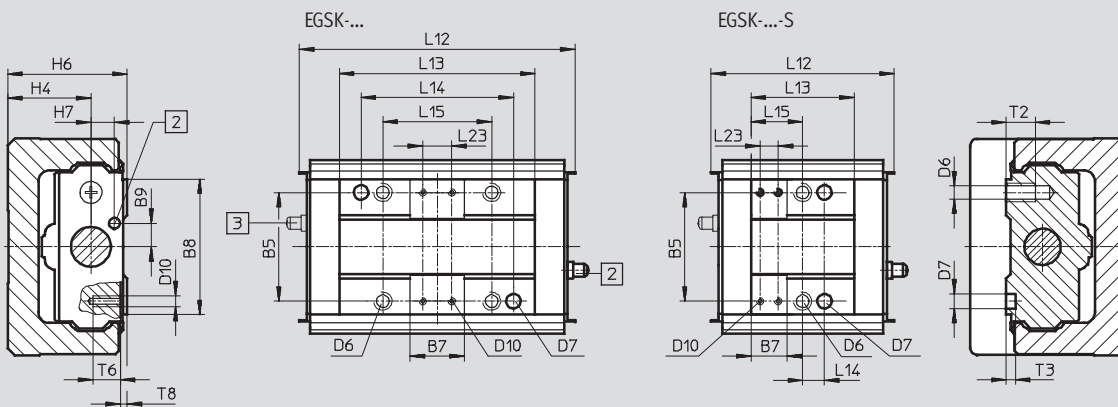
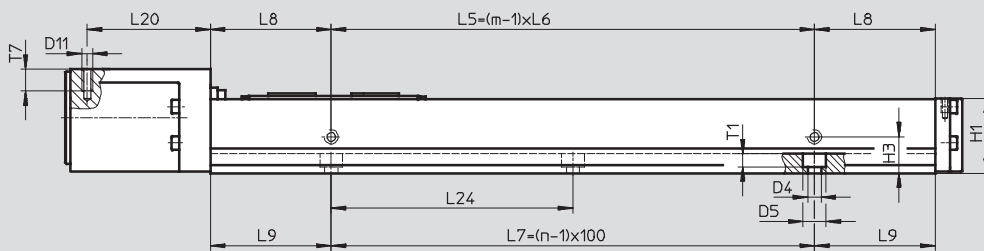
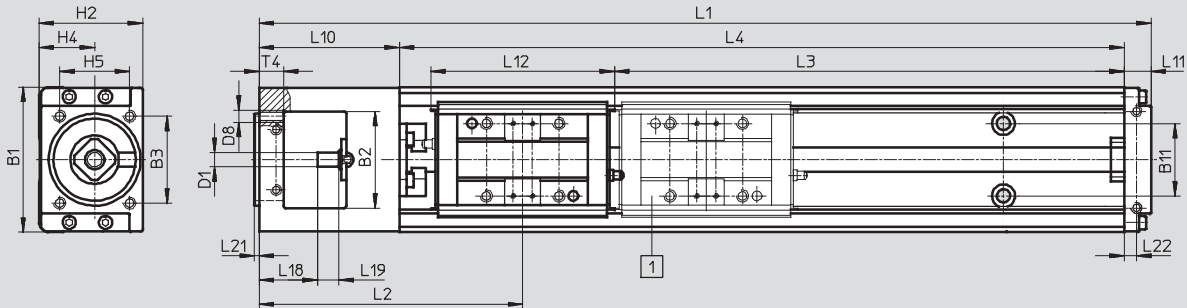

### Note

The additional slide has the same overall length as the driven slide.

- 1 Additional slide
- 2 Lubrication nipple

- 3 The lubrication nipple is in the direction of the drive cover on the version with additional slide (EGSK-...-Z)

# Electric slides EGSK

Technical data



Size	Stroke	L1	L3 +4		L4	L5	L6	L7	L8	m	n
				S							
33	100	269	110	135	200	100	100	100	50	2	2
	200	369	210	235	300	200	200	200	50	2	3
	300	469	310	335	400	200	200	300	100	2	4
	400	569	410	435	500	400	200	400	50	3	5
	500	669	510	535	600	400	200	500	100	3	6
	600	769	610	635	700	600	200	600	50	4	7

Size	Stroke	L1	L3 +4		L4	L5	L6	L7	L8	m	n
				S							
46	200	425.5	206	244	340	200	200	200	70	2	3
	300	525.5	306	344	440	400	200	300	20	3	4
	400	625.5	406	444	540	400	200	400	70	3	5
	500	725.5	506	544	640	600	200	500	20	4	6
	600	825.5	606	644	740	600	200	600	70	4	7
	800	1,025.5	806	844	940	800	200	800	70	5	9

Size	B1	B2	B3 ±0.1	B5 ±0.04	B6 ±0.1	B7	B8	B9	B10 ±0.1	B11	D1 ∅ h7	D2 ∅ g7	D3 ∅	D4 ∅	D5 ∅
33	60	40	36	30	25	15	37.4	6.5	40	30	6	38	34	5.5	9.5
46	86	48	36	46	42	15	54.4	10	58	46	8	38	34	6.6	11

Size	D6	D7 ∅ H7	D8	D9	D10	D11	H1	H2	H3	H4	H5 ±0.1	H6	H7	L2	
															S
33	M5	4	M5	M2.6	M2	M3	31	43	15	23	29	33	6.5	105	92.3
46	M6	5	M5	M2.6	M2	M4	43.5	60	28	32	29	46	9	142.5	123.8

Size	L9	L10	L11	L12		L13		L14		L15		L16	L17	L18	L19
					S		S	±0.04	±0.1		S				
33	50	58	11	76	50.5	54	28.5	42	6	30	14.25	26	22	24	9
46	70	72.5	13	110	72.5	81	43.5	28	11	46	21.75	33.5	25	21.5	18

Size	L20 ±0.1	L21	L22 ±0.1	L23		L24	T1	T2	T3	T4	T5	T6	T7	T8
					S									
33	51	2	5	8	5	100	5.4	8	2.5	10	4	5	6	1
46	65.5	2	3.5	8	8	100	6.5	12	2.5	10	4	5	8	1

# Electric slides EGSK

Technical data

Ordering data – Electric slides with standard slide					
Size	Stroke [mm]	Part No.	Type	Part No.	Type
		Spindle pitch 1 mm		Spindle pitch 6 mm	
20	25	562758	EGSK-20-25-1P	562761	EGSK-20-25-6P
	75	562759	EGSK-20-75-1P	562762	EGSK-20-75-6P
	125	562760	EGSK-20-125-1P	562763	EGSK-20-125-6P

Size	Stroke [mm]	Part No.	Type	Part No.	Type
		Spindle pitch 2 mm		Spindle pitch 6 mm	
26	50	562764	EGSK-26-50-2P	562768	EGSK-26-50-6P
	100	562765	EGSK-26-100-2P	562769	EGSK-26-100-6P
	150	562766	EGSK-26-150-2P	562770	EGSK-26-150-6P
	200	562767	EGSK-26-200-2P	562771	EGSK-26-200-6P

Size	Stroke [mm]	Part No.	Type	Part No.	Type
		Spindle pitch 6 mm		Spindle pitch 10 mm	
33	100	562772	EGSK-33-100-6P	562778	EGSK-33-100-10P
	200	562773	EGSK-33-200-6P	562779	EGSK-33-200-10P
	300	562774	EGSK-33-300-6P	562780	EGSK-33-300-10P
	400	562775	EGSK-33-400-6P	562781	EGSK-33-400-10P
	500	562776	EGSK-33-500-6P	562782	EGSK-33-500-10P
	600	562777	EGSK-33-600-6P	562783	EGSK-33-600-10P

Size	Stroke [mm]	Part No.	Type	Part No.	Type
		Spindle pitch 10 mm		Spindle pitch 20 mm	
46	200	562784	EGSK-46-200-10P	562790	EGSK-46-200-20P
	300	562785	EGSK-46-300-10P	562791	EGSK-46-300-20P
	400	562786	EGSK-46-400-10P	562792	EGSK-46-400-20P
	500	562787	EGSK-46-500-10P	562793	EGSK-46-500-20P
	600	562788	EGSK-46-600-10P	562794	EGSK-46-600-20P
	800	562789	EGSK-46-800-10P	562795	EGSK-46-800-20P

# Electric slides EGSK

Ordering data – Modular products



Ordering table									
Size	15	20	26	33	46	Conditions	Code	Enter code	
<b>M</b> Module No.	<b>562749</b>	<b>562750</b>	<b>562751</b>	<b>562752</b>	<b>562753</b>				
Drive function	Electric slide drive							<b>EGSK</b>	EGSK
Size	15	20	26	33	46		-...	-...	
Standard stroke for standard slide [mm]	25	-		-			-25	-...	
	50	-	50	-	-		-50	-...	
	75	-		-			-75	-...	
	100	-	100	-	-		-100	-...	
	-	125	-		-		-125	-...	
	-	-		150	-	-		-150	-...
	-	-		200	-		-200	-...	
	-	-			300	-	-300	-...	
	-	-			400	-	-400	-...	
	-	-			500	-	-500	-...	
	-	-			600	-	-600	-...	
	-	-				800	-	-800	-...
	Standard stroke for slide, short [mm]	-	-		130	-	-130	-...	
-		-		230	-	-230	-...		
-		-			240	-	-240	-...	
-		-			330	-	-330	-...	
-		-			340	-	-340	-...	
-		-			430	-	-430	-...	
-		-			440	-	-440	-...	
-		-			530	-	-530	-...	
-		-			540	-	-540	-...	
-		-			630	-	-630	-...	
-		-			640	-	-640	-...	
Spindle pitch [mm]	1	-		-			-1P	-...	
	2	-	2	-	-		-2P	-...	
	-	6	-		-		-6P	-...	
	-	-	-	10	-		-10P	-...	
	-	-			20	-	-20P	-...	
<b>O</b> Accuracy	-	Standard accuracy						-	-...
	-	Greater accuracy						-H	-...
	-	Precision accuracy					<b>1</b>	-P	-...
Slide design	Standard slide						-	-...	
	-			Slide, short			-S	-...	
Additional slide	No additional slide						-	-...	
	Additional slide (additional slide Z in combination with slide design S also results in a short slide)					<b>2</b>	-Z	-...	

- 1 P** With size 33 not in combination with stroke for standard slide 600 and stroke for slide, short 630  
With size 46 not in combination with stroke for standard slide 800 and stroke for slide, short 840
- 2 Z** With size 15 not in combination with stroke for standard slide 25 and stroke for standard slide 50  
With size 20 not in combination with stroke for standard slide 25  
With size 26 not in combination with stroke for standard slide 50  
With size 33 not in combination with stroke for standard slide 100

### Transfer order code

**EGSK** -  -  -  -  -  -  -

# Electric slides EGSP

Type codes

		EGSP	-	26	-	150	-	2P	-	H	-		-	Z
<b>Type</b>														
EGSP	Electric slide													
<b>Size</b>														
<b>Stroke [mm]</b>														
<b>Spindle pitch</b>														
<b>Accuracy</b>														
-	Standard													
H	High accuracy													
P	Precision design													
<b>Slide design</b>														
-	Standard slide													
S	Slide, short													
<b>Additional slide</b>														
-	No additional slide													
Z	Additional slide													



# Electric slides EGSP

## Technical data

Function

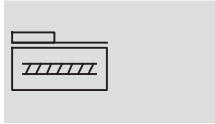

- N- Size  
20 ... 46
- T- Stroke length  
25 ... 840 mm



General technical data											
Size			20		26		33			46	
Spindle pitch			1	6	2	6	6	10	20	10	20
	Code <sup>1)</sup>										
Constructional design	Electromechanical linear axis with recirculating ball bearing spindle										
Guide	Recirculating ball bearing guide										
Installation position	Any										
Type of mounting for effective load	Female thread										
	Locating pin										
Working stroke <sup>2)</sup>	-	[mm]	25 ... 125		50 ... 200		100 ... 600			200 ... 800	
	S	[mm]	-		-		130 ... 630			240 ... 840	
Max. feed force	-/H <sup>3)</sup>	[N]	69	72	168	164	370	227	165	365	267
F <sub>x,max</sub>	P <sup>4)</sup>	[N]	87	112	212	212	466	286	208	460	337
Max. driving torque	-/H <sup>3)</sup>	[Ncm]	1.1	6.9	5.3	16	35	36	53	58	85
M <sub>Driving,max</sub>	P <sup>4)</sup>	[Ncm]	1.4	11	6.7	20	45	46	66	73	107
No-load torque	-/H	[Ncm]	0.5	0.5	1.5	1.5	7	7	7	10	10
M <sub>No-load</sub>	P	[Ncm]	1.2	1.2	4.0	4.0	15	15	15	17	17
Max. rotational speed <sup>5)</sup>		[1/min]	6,000	6,000	6,000	6,000	6,000	6,000	6,000	6,000	6,000
Max. speed <sup>5)</sup>	-/H	[m/s]	0.1	0.6	0.2	0.6	0.6	1	2	1	2
	P	[m/s]	0.1	0.6	0.2	0.6	0.6	1	2	1	2
Max. acceleration		[m/s <sup>2</sup> ]	10		10		20			20	
Homing	Inductive proximity sensor SIES-8M										

- 1) Variant code → 24
- 2) Maximum travel distance → 33  
In combination with an additional slide, the working stroke is reduced by the length of the additional slide and the distance between the two slides
- 3) Loads are based on a service life specification of 5 x 10<sup>8</sup> rotations
- 4) Loads are based on a service life specification of 2.5 x 10<sup>8</sup> rotations
- 5) Reduced speeds with sizes 33 and 46 with long strokes → 27

Operating and environmental conditions		
Ambient temperature	[°C]	0 ... +40
Relative air humidity	[%]	0 ... 95 (non-condensing)

Weight [kg]											
Size			20		26		33		46		
	Code <sup>1)</sup>										
Basic weight with 0 mm stroke <sup>2)</sup>	-		0.38	0.78	1.38	3.60					
	S		-	-	1.30	3.30					
Additional weight per 100 mm stroke	-		0.27	0.42	0.72	1.40					
Moving load	-		0.07	0.15	0.31	0.91					
	S		-	-	0.17	0.57					
Additional slide Z	-		0.07	0.15	0.31	0.91					
	S		-	-	0.17	0.57					

- 1) Variant code → 24
- 2) Including slide, without additional slide

# Electric slides EGSP

Technical data

FESTO

Accuracy data [μm]			20		26		33		46	
Size	Stroke	Code <sup>1)</sup>								
Repetition accuracy <sup>2)</sup>		–	±10		±10		±10		±10	
		H	±5		±5		±5		±5	
		P	±3		±3		±3		±3	
Running parallelism	25 ... 340	H	25		25		25		35	
	400 ... 540	H	–		–		35		35	
	600 ... 640	H	–		–		40		40	
	800 ... 840	H	–		–		–		50	
	25 ... 340	P	10		10		10		15	
	400 ... 540	P	–		–		15		15	
Max. reversing play		–	20		20		20		20	
		H	10		10		20		20	
		P	3		3		3		3	

1) Variant code → 24

2) The repetition accuracy that can be achieved with a motor/axis system is also influenced by the angle resolution of the motor and the chosen control parameters. The specified repetition accuracy cannot, therefore, be achieved with all motors.

## Materials

Sectional view

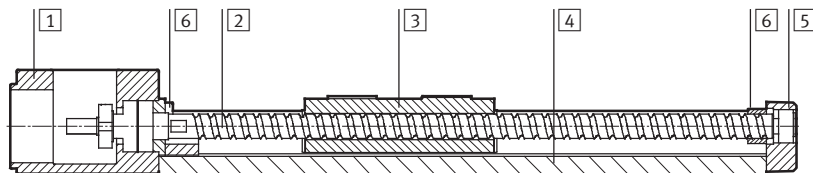

Electric slide		
1	Drive cover	Die-cast aluminium, coated
2	Spindle	Steel
3	Slide	Steel
4	Profile	High-alloy steel
5	End cap	Die-cast aluminium, coated
6	Buffer	Ethylene vinyl acetate copolymer
Note on materials		RoHS-compliant
		Contains PWIS (paint-wetting impairment substances)

Mass moment of inertia										
Size		20		26		33			46	
Spindle pitch		1	6	2	6	6	10	20	10	20
	Code <sup>1)</sup>									
J <sub>0</sub>	[kg mm <sup>2</sup> ]	0.087	0.143	0.355	0.479	2.72	3.22	5.57	8.51	15.42
	S [kg mm <sup>2</sup> ]	–	–	–	–	1.93	2.21	–	6.10	10.43
J <sub>S</sub> per 100 mm stroke	[kg mm <sup>2</sup> /100 mm]	0.099		0.314		0.766			3.877	
J <sub>L</sub> per kg effective load	[kg mm <sup>2</sup> /kg]	0.03	0.91	0.10	0.91	0.91	2.53	10.13	2.53	10.13
J <sub>W</sub> per additional slide	[kg mm <sup>2</sup> ]	0.002	0.058	0.016	0.14	0.28	0.79	3.14	2.31	9.22
	S [kg mm <sup>2</sup> ]	–	–	–	–	0.16	0.43	–	1.44	5.78

1) Variant code → 24

The mass moment of inertia J<sub>A</sub> of the entire axis is calculated as follows:

$$J_A = J_0 + J_W + J_S \times \text{working stroke} + J_L \times m_{\text{effective load}}$$

# Electric slides EGSP

Technical data

FESTO

## Speed v, rotational speed n as a function of working stroke l

EGSP-33-...-6P

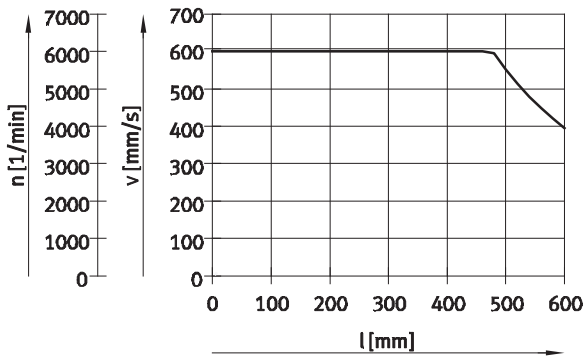

EGSP-33-...-10P

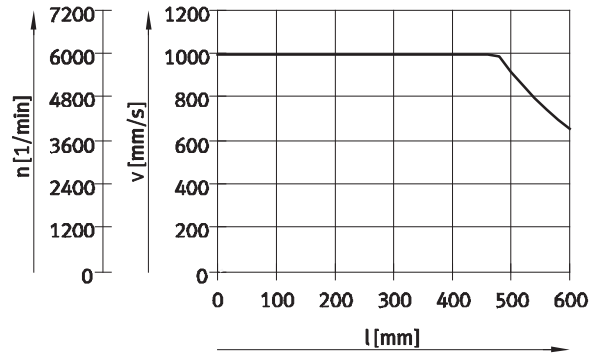

EGSP-33-...-20P

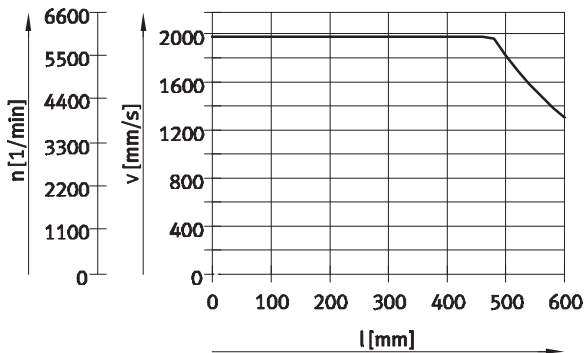

EGSP-46-...-10P

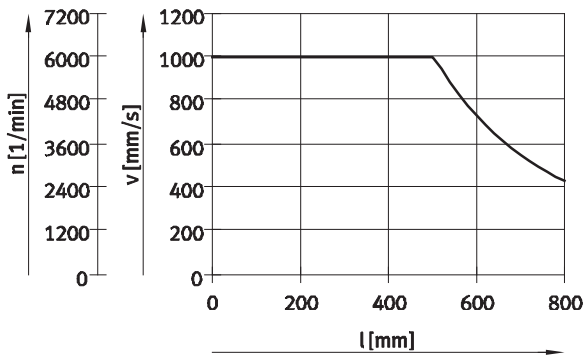

EGSP-46-...-20P

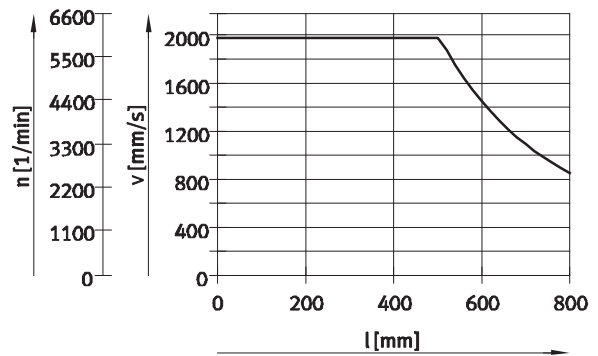

## 2nd moment of area

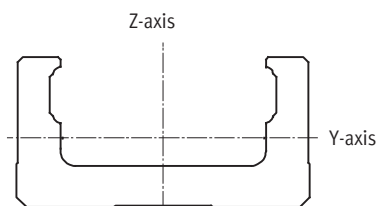

Size		20	26	33	46
ly	[mm <sup>4</sup> ]	6,000	16,600	53,500	205,000
lz	[mm <sup>4</sup> ]	61,400	148,000	352,000	1,450,000

# Electric slides EGSP

Technical data



## Characteristic load values

The indicated forces and torques refer to the centre axis of the spindle.

The coordinate zero point is the point where the centre of the guide and the longitudinal centre of the slide intersect.

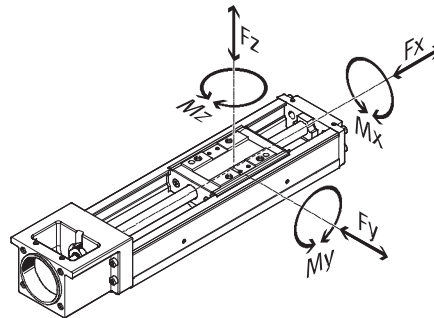

### Note

PositioningDrives  
sizing software  
www.festo.com

## Permissible dynamic forces and torques<sup>1)</sup>

Size			20		26		33			46	
Spindle pitch			1	6	2	6	6	10	20	10	20
	Code <sup>2)</sup>										
F <sub>y</sub> max., F <sub>z</sub> max.	-/H <sup>3)</sup>	- [N]	2,325	1,279	3,991	2,767	3,619	3,052	2,422	7,092	5,629
	P <sup>4)</sup>	- [N]	2,929	1,612	5,028	3,486	4,559	3,845	3,052	8,935	7,092
	-/H <sup>3)</sup>	S [N]	-	-	-	-	2,405	2,029	-	5,099	4,047
	P <sup>4)</sup>	S [N]	-	-	-	-	3,031	2,556	-	6,424	5,099
M <sub>x</sub> max.	-/H <sup>3)</sup>	- [Nm]	28.8	15.9	64.7	44.8	71.7	60.4	48.0	205	163
	P <sup>4)</sup>	- [Nm]	36.3	20.0	81.5	56.5	90.3	76.1	60.4	258	205
	-/H <sup>3)</sup>	S [Nm]	-	-	-	-	47.6	40.2	-	147	117
	P <sup>4)</sup>	S [Nm]	-	-	-	-	60.0	50.6	-	186	147
M <sub>y</sub> max., M <sub>z</sub> max.	-/H <sup>3)</sup>	- [Nm]	9.9	5.5	25.1	17.4	25.5	21.5	17.1	74.6	59.2
	P <sup>4)</sup>	- [Nm]	12.5	6.9	31.6	21.9	32.1	27.1	21.5	94.0	74.6
	-/H <sup>3)</sup>	S [Nm]	-	-	-	-	10.1	8.5	-	34.9	27.7
	P <sup>4)</sup>	S [Nm]	-	-	-	-	12.7	10.7	-	44.0	34.9

- 1) Calculated with a speed-dependent load factor  $f_w$  of 1.2
- 2) Variant code → 24
- 3) Loads are based on a service life specification of  $5 \times 10^8$  rotations and a load factor  $f_w$  of 1.2
- 4) Loads are based on a service life specification of  $2.5 \times 10^8$  rotations and a load factor  $f_w$  of 1.2

## Basic load ratings

Size			20		26		33			46	
Spindle pitch			1	6	2	6	6	10	20	10	20
	Code <sup>1)</sup>										
<b>Ball screw</b>											
Static C <sub>0</sub> ,ball screw	-/H	[N]	1,170	1,450	4,020	3,510	6,290	3,780	3,770	6,990	7,040
	P	[N]	1,170	1,600	4,020	3,900	6,290	3,780	3,770	6,990	7,040
Dynamic C <sub>dyn</sub> ,ball screw	-/H <sup>2)</sup>	[N]	660	860	2,350	1,950	4,400	2,700	2,620	4,350	4,240
	P <sup>2)</sup>	[N]	660	1,060	2,350	2,390	4,400	2,700	2,620	4,350	4,240
<b>Fixed bearing</b>											
Static C <sub>0</sub> ,bearing		[N]	735		1,230		2,700			3,330	
Dynamic C <sub>dyn</sub> ,bearing <sup>2)</sup>		[N]	1,150		2,000		6,250			6,700	

- 1) Variant code → 24
- 2) Dynamic basic load ratings are based on a basic service life of  $10^6$  rotations

# Electric slides EGSP

Technical data

FESTO

Basic load ratings											
Size			20		26		33			46	
Spindle pitch			1	6	2	6	6	10	20	10	20
Code <sup>1)</sup>											
Linear guide											
Static $C_{0,guide}$	-	[N]	8,030		16,500		20,400			45,900	
	S	[N]	-		-		11,500			-	
Dynamic $C_{dyn,guide}$ <sup>2)</sup>	-	[N]	4,770		10,318		13,493			31,351	
	S	[N]	-		-		8,969			-	
Torque equivalence factors											
$k_x$	-	[1/m]	80.7		61.7		50.5			34.6	
	S	[1/m]	-		-		50.5			-	
$k_y, k_z$	-	[1/m]	234.4		159.1		142			95.1	
	S	[1/m]	-		-		239.1			-	

1) Variant code → 24

2) Dynamic basic load ratings are based on a basic service life of 100 km

## Speed-dependent load factor $f_w$

$f_w = 1.0 \dots 1.2$  ( $v \leq 0.25$  m/s)

$f_w = 1.2 \dots 1.5$  ( $0.25$  m/s  $\leq v \leq 1.0$  m/s)

$f_w = 1.5 \dots 2.0$  ( $1.0$  m/s  $\leq v \leq 2.0$  m/s)

$f_w = 2.0 \dots 3.5$  ( $v \geq 2.0$  m/s)

## Calculation of the maximum force $F_x$

$$F_{x,max} = \frac{1}{f_w} \times \frac{\text{Min}[C_{dyn,KGT}; C_{dyn,bearing}]}{\sqrt[3]{\frac{L_{ref,rot}}{10^6}}}$$

## Calculation of the maximum forces $F_{y/z}$ and torques $M_{x/y/z}$

$$F_{y/z,max} = \frac{1}{f_w} \times \frac{C_{dyn,guide}}{\sqrt[3]{\frac{L_{ref,km}}{100km}}}$$

$$M_{x/y/z,max} = \frac{1}{k_{x/y/z}} \times \frac{1}{f_w} \times \frac{C_{dyn,guide}}{\sqrt[3]{\frac{L_{ref,km}}{100km}}}$$

# Electric slides EGSP

Technical data



Calculation of the service life										
Size	20			26		33			46	
Spindle pitch P	1	6		2	6	6	10	20	10	20
	Code <sup>1)</sup>									
Reference service life	-/H	5 x 10 <sup>8</sup>								
in rotations, L <sub>ref,rot</sub>	P	2.5 x 10 <sup>8</sup>								
Reference service life	-/H [km]	500	3,000	1,000	3,000	3,000	5,000	10,000	5,000	10,000
in kilometres, L <sub>ref,km</sub>	P [km]	250	1,500	500	1,500	1,500	2,500	5,000	2,500	5,000

1) Variant code → 24

## 1 Representation of the loads

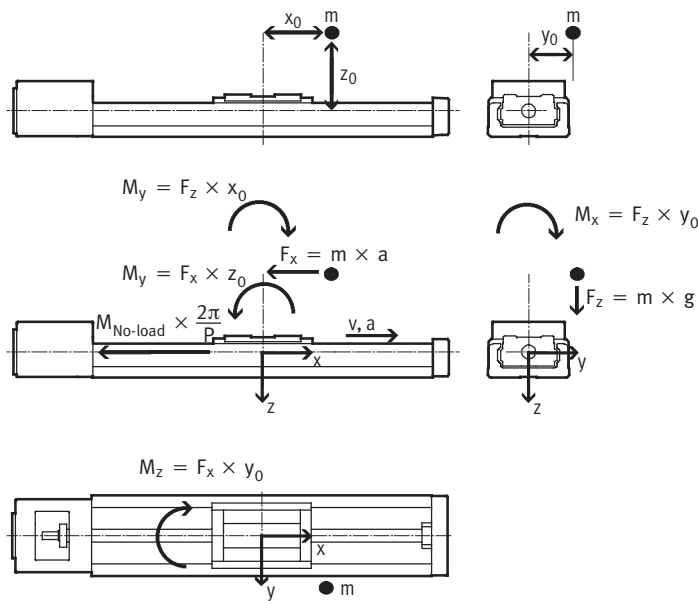

## 2 Determination of the loads over the travel cycle

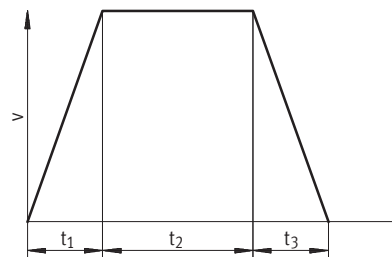

$$q_1 = \frac{t_1}{t_{tot}} \quad q_2 = \frac{t_2}{t_{tot}} \quad q_3 = \frac{t_3}{t_{tot}}$$

$$t_{tot} = t_1 + t_2 + t_3$$

v	Speed
t <sub>1</sub>	Acceleration time
t <sub>2</sub>	Constant travel time
t <sub>3</sub>	Deceleration time
q <sub>1/2/3</sub>	Relative time of the cycle phases
t <sub>tot</sub>	Cycle time

## Ball screw

For t<sub>1</sub>:  $F_{x1} = - (m \times a) - (M_{No-load} \times \frac{2\pi}{P})$

For t<sub>2</sub>:  $F_{x2} = - (M_{No-load} \times \frac{2\pi}{P})$

For t<sub>3</sub>:  $F_{x3} = m \times a - (M_{No-load} \times \frac{2\pi}{P})$

F <sub>x1/2/3</sub>	Calculated force load per cycle phase
F <sub>x,dyn</sub>	Calculated average force load
m	Effective load (centre of gravity)
a	Acceleration
M <sub>No-load</sub>	No-load torque → 25
P	Spindle pitch → 25
q <sub>1/2/3</sub>	Relative time of the cycle phases

$$F_{x,dyn} = \sqrt[3]{q_1 \times |F_{x1}|^3 + q_2 \times |F_{x2}|^3 + q_3 \times |F_{x3}|^3}$$

# Electric slides EGSP

Technical data

## 2 Determination of the loads over the travel cycle

### Linear guide

<b>For t<sub>1</sub>: a →, v →</b>	$F_{y1} = 0$	$F_{y1/2/3},$ $F_{z1/2/3}$	Calculated force load per cycle phase
$F_{z1} = m \times g$			
$M_{x1} = F_z \times y_0 = m \times g \times y_0$		$M_{x1/2/3},$ $M_{y1/2/3},$ $M_{z1/2/3}$	Calculated torque load per cycle phase
$M_{y1} = -F_z \times x_0 + F_x \times z_0 = -m \times g \times x_0 + m \times a \times z_0$			
$M_{z1} = F_x \times y_0 = m \times a \times y_0$		$F_{y/z,dyn}$	Calculated average force load
<b>For t<sub>2</sub>: a = 0, v →</b>	$F_{y2} = 0$	$M_{x/y/z,dyn}$	Calculated average torque load
$F_{z2} = m \times g$		$m$	Effective load (centre of gravity)
$M_{x2} = F_z \times y_0 = m \times g \times y_0$		$g$	Gravitational acceleration
$M_{y2} = -F_z \times x_0 = -m \times g \times x_0$		$a$	Acceleration
$M_{z2} = 0$		$x_0, y_0, z_0$	Distances between the centre of gravity of the effective load and the slide centre point
<b>For t<sub>3</sub>: a ←, v →</b>	$F_{y3} = 0$	$q_{1/2/3}$	Relative time of the cycle phases
$F_{z3} = m \times g$			
$M_{x3} = F_z \times y_0 = m \times g \times y_0$			
$M_{y3} = -F_z \times x_0 - F_x \times z_0 = -m \times g \times x_0 - m \times a \times z_0$			
$M_{z3} = -F_x \times y_0 = -m \times a \times y_0$			

$$F_{y,dyn} = \sqrt[3]{q_1 \times |F_{y1}|^3 + q_2 \times |F_{y2}|^3 + q_3 \times |F_{y3}|^3}$$

$$F_{z,dyn} = \sqrt[3]{q_1 \times |F_{z1}|^3 + q_2 \times |F_{z2}|^3 + q_3 \times |F_{z3}|^3}$$

$$M_{x,dyn} = \sqrt[3]{q_1 \times |M_{x1}|^3 + q_2 \times |M_{x2}|^3 + q_3 \times |M_{x3}|^3}$$

$$M_{y,dyn} = \sqrt[3]{q_1 \times |M_{y1}|^3 + q_2 \times |M_{y2}|^3 + q_3 \times |M_{y3}|^3}$$

$$M_{z,dyn} = \sqrt[3]{q_1 \times |M_{z1}|^3 + q_2 \times |M_{z2}|^3 + q_3 \times |M_{z3}|^3}$$

## 3 Total load

### Ball screw

$\frac{ F_{x,dyn} }{F_{x,max}} \leq f_v$	$F_{x,dyn}$	Calculated average force load
	$F_{x,max}$	Max. permissible force load → 25
	$f_v$	Load comparison factor → 32

### Linear guide

$\frac{ F_{y,dyn} }{F_{y,max}} + \frac{ F_{z,dyn} }{F_{z,max}} + \frac{ M_{x,dyn} }{M_{x,max}} + \frac{ M_{y,dyn} }{M_{y,max}} + \frac{ M_{z,dyn} }{M_{z,max}} \leq f_v$	$F_{y/z,dyn}$	Calculated average force load
	$F_{y/z,max}$	Max. permissible force load → 28
	$M_{x/y/z,dyn}$	Calculated average torque load
	$M_{x/y/z,max}$	Max. permissible torque load → 28
	$f_v$	Load comparison factor → 32

# Electric slides EGSP

Technical data

## 4 Determination of the load comparison factor $f_v$

$$f_v = \frac{1}{\sqrt[3]{q}} \quad \text{with} \quad q = \frac{L_{\text{calc,km}}}{L_{\text{ref,km}}} = \frac{L_{\text{calc,rot}}}{L_{\text{ref,rot}}}$$

for  $q = 1$ :

Calculated service life (here desired service life)  $L_{\text{calc,km}} = 1 \times$  reference service life  $L_{\text{ref,km}}$  gives  $f_v = 1$

for  $q \neq 1$ :

Calculated service life (here desired service life)  $L_{\text{calc,km}} = q \times$  reference service life  $L_{\text{ref,km}}$  read off ( $\rightarrow$  graph) or calculate  $f_v$

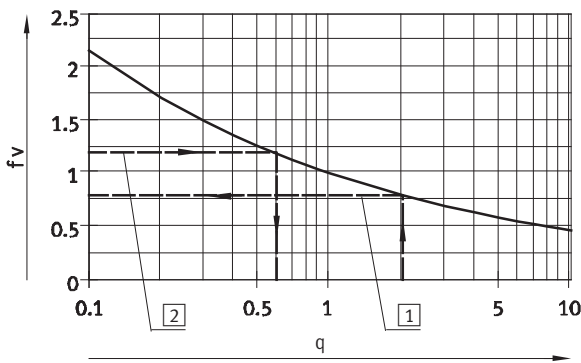

- 1  $\rightarrow$  Example 1
- 2  $\rightarrow$  Example 2

$f_v$	Load comparison factor
$q$	Quotient of desired service life divided by reference service life
$L_{\text{calc, km}}$	Calculated service life in km
$L_{\text{ref, km}}$	Reference service life in km $\rightarrow$ 30
$L_{\text{calc, rot}}$	Calculated service life in rotations
$L_{\text{ref, rot}}$	Reference service life in rotations $\rightarrow$ 30

## 5 Calculation examples

### Example 1:

EGSP-26-...-2P-H-...

$L_{\text{ref,km}} = 1,000 \text{ km}$

$L_{\text{calc,km}} = 2,000 \text{ km}$

$$q = \frac{2000\text{km}}{1000\text{km}} = 2.0$$

$$f_v = \frac{1}{\sqrt[3]{q}} = 0.79$$

Result:

A desired service life of 200% of the reference service life means that the permissible total load must be 21% lower.

### Example 2:

If the total load calculation gives a load comparison factor  $f_v$  of 1.2, the mathematical service life is only approx. 60% ( $x = 0.6 \rightarrow$  graph) of the reference service life.

$$q = \frac{1}{f_v^3} = 0.58$$

## 6 Static sizing

### Ball screw

$$F_{x,\text{stat}} = \text{Max}[F_{x1}, F_{x2}, F_{x3}] \leq \frac{C_{0,\text{KGT}}}{f_s}$$

$F_{x,\text{stat}}$	Maximum value of the calculated force load per cycle phase	$C_{0,\text{KGT}}$	Static basic load rating of ball screw $\rightarrow$ 28
$F_{x1/2/3}$	Calculated force load per cycle phase	$f_s$	Safety factor against static overload $f_s = 1.0 \dots 3.0$

### Linear guide

$$F_{y,\text{stat}} = \text{Max}[F_{y1}, F_{y2}, F_{y3}] \leq \frac{C_{0,\text{guide}}}{f_s}$$

$$F_{z,\text{stat}} = \text{Max}[F_{z1}, F_{z2}, F_{z3}] \leq \frac{C_{0,\text{guide}}}{f_s}$$

$$M_{x,\text{stat}} = \text{Max}[M_{x1}, M_{x2}, M_{x3}] \leq \frac{1}{k_x} \times \frac{C_{0,\text{guide}}}{f_s}$$

$$M_{y,\text{stat}} = \text{Max}[M_{y1}, M_{y2}, M_{y3}] \leq \frac{1}{k_y} \times \frac{C_{0,\text{guide}}}{f_s}$$

$$M_{z,\text{stat}} = \text{Max}[M_{z1}, M_{z2}, M_{z3}] \leq \frac{1}{k_z} \times \frac{C_{0,\text{guide}}}{f_s}$$

$F_{y/z,\text{stat}}$	Maximum value of the calculated force load per cycle phase	$M_{x1/2/3}, M_{y1/2/3}, M_{z1/2/3}$	Calculated torque load per cycle phase
$M_{x/y/z,\text{stat}}$	Maximum value of the calculated torque load per cycle phase	$C_{0,\text{guide}}$	
$F_{y1/2/3}, F_{z1/2/3}$	Calculated force load per cycle phase	$k_{x/y/z}$	Torque equivalence factors $\rightarrow$ 29
		$f_s$	Safety factor against static overload $f_s = 1.0 \dots 3.0$



# Electric slides EGSP

Technical data

## Dimensions

Download CAD Data → [www.festo.com/us/cad](http://www.festo.com/us/cad)

EGSP-20/26

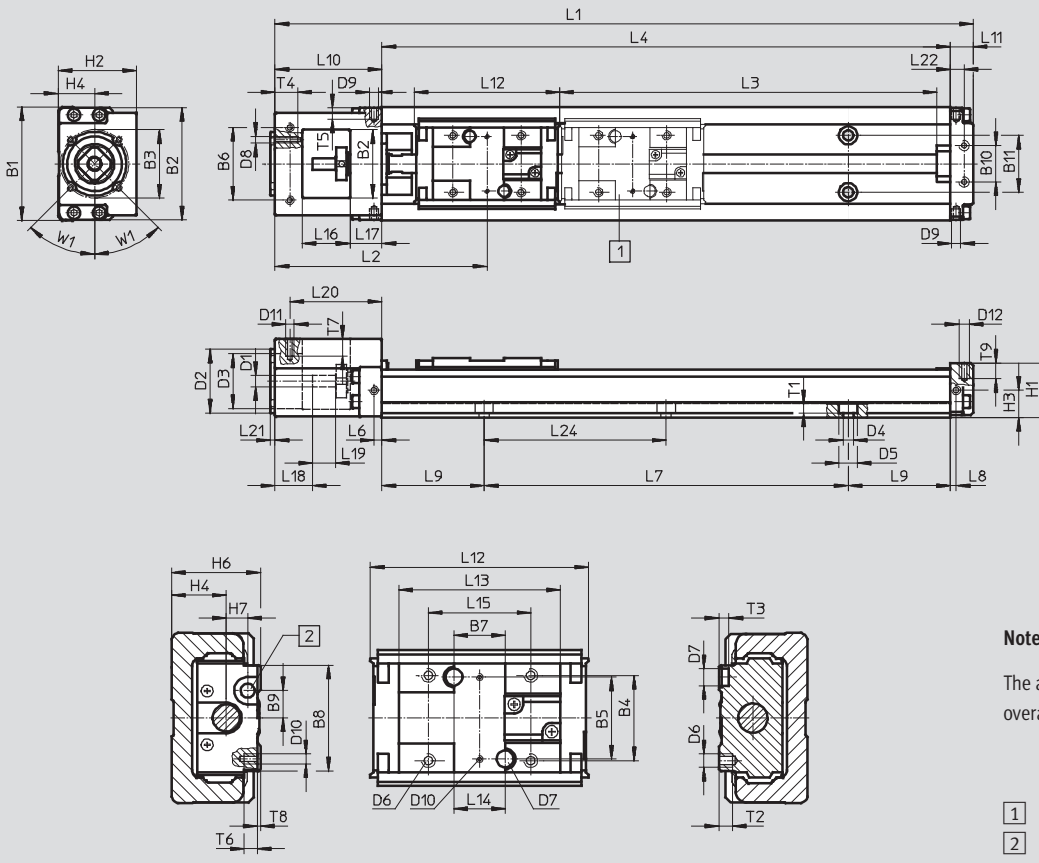

### Note

The additional slide has the same overall length as the driven slide.

- 1) Additional slide
- 2) Lubrication hole

Size	Stroke	L1	L3 +4	L4	L7= (n-1)x60	L9	n	Size	Stroke	L1	L3 +4	L4	L7= (n-1)x80	L9	n
20	25	152	39	100	60	20	2	26	50	207	67	150	80	35	2
	75	202	89	150	120	15	3		100	257	117	200	160	20	3
	125	252	139	200	120	40	3		150	307	167	250	160	45	3
									200	357	217	300	240	30	4

Size	B1	B2	B3 Ø	B4	B5 ±0.02	B6 ±0.1	B7	B8	B9	B10 ±0.1	B11	D1 Ø h7	D2 Ø g7	D3 Ø	D4 Ø	D5 Ø	D6	D7 Ø H7	D8
20	40	22	30	18	18	29	10	23	5.5	18	18	4	28	22	3.4	6.5	M3	2	M3
26	50	30	30	25	24	32	15	31	8	16	25	5	28	24	4.5	8	M4	5	M3

Size	D9	D10	D11	D12	H1	H2	H3	H4	H6	H7	L2	L6	L8	L10	L11	L12	L13	L14 <sup>1)</sup>
																		±0.02
20	M2.6	M1.6	M2.5	M2.5	19	28	10	13	20	4	72.8	3.5	2.5	42	10	46	33.2	10
26	M2.6	M2	M2.5	M3	24	34.5	12	16	26	6.3	91.3	3.5	2.5	47	10	64	47.4	15

Size	L15	L16	L17	L18	L19 ±0.1	L20 ±0.1	L21	L22	L24	T1	T2	T3	T4	T5	T6	T7	T8	T9	W1
20	20	18	12	16	8	34.5	2	6.5	60	3	3	3	10	4	2.4	5	0.9	5	45°
26	30	21	14	16.5	10	40.5	2	6	80	4	4	3	10	4	3	5	0.9	6	45°

1) Distance between the locating holes

# Electric slides EGSP

Technical data

FESTO

## Dimensions

Download CAD Data → [www.festo.com/us/cad](http://www.festo.com/us/cad)

EGSP-33/46

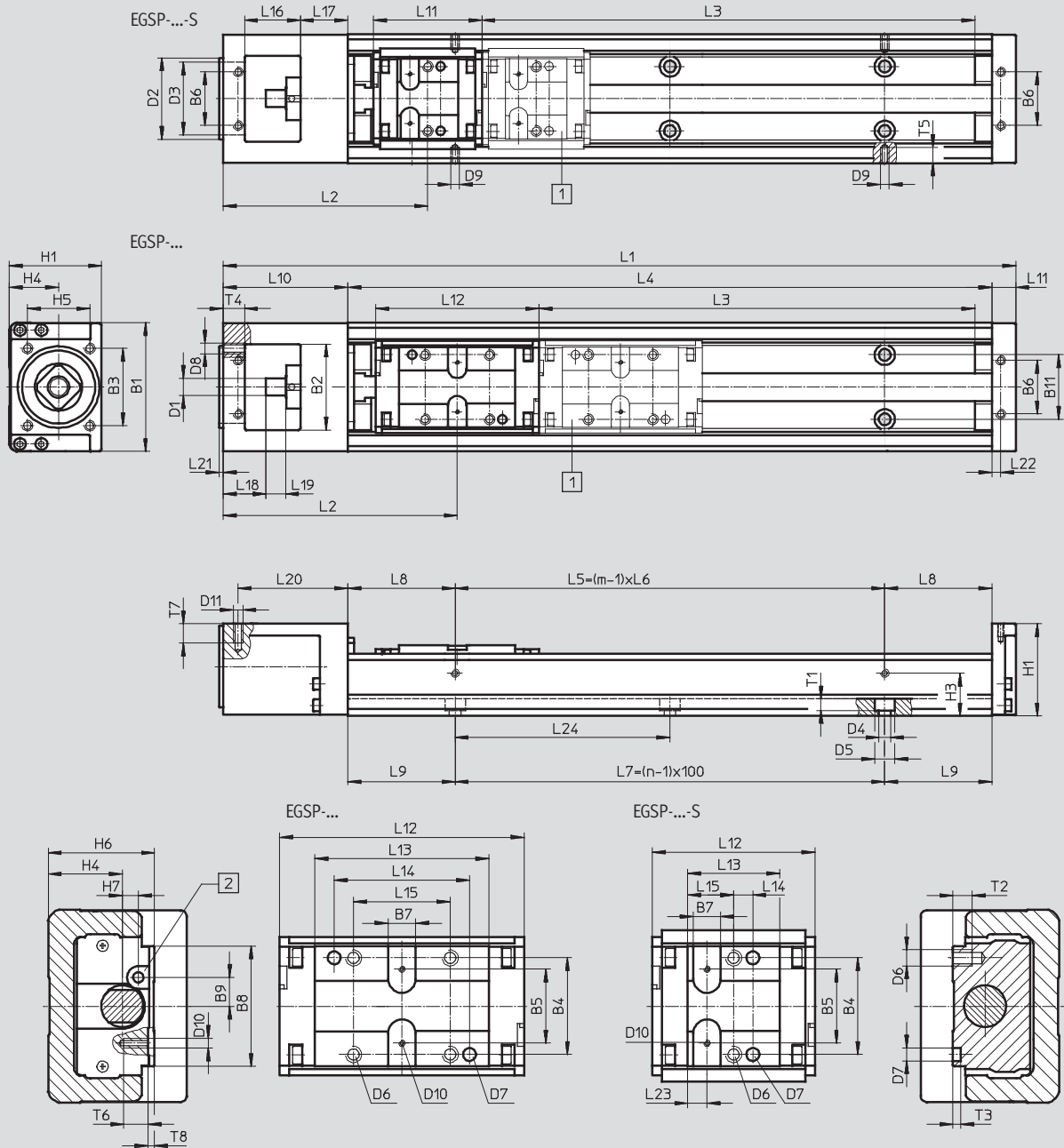

### Note

The additional slide has the same overall length as the driven slide.

- 1 Additional slide
- 2 Lubrication hole

# Electric slides EGSP

Technical data



Size	Stroke	L1	L3 +4		L4	L5	L6	L7	L8	m	n
				S							
33	100	269	103	130	200	100	100	100	50	2	2
	200	369	203	230	300	200	200	200	50	2	3
	300	469	303	330	400	200	200	300	100	2	4
	400	569	403	430	500	400	200	400	50	3	5
	500	669	503	530	600	400	200	500	100	3	6
	600	769	603	630	700	600	200	600	50	4	7

Size	Stroke	L1	L3 +4		L4	L5	L6	L7	L8	m	n
				S							
46	200	425.5	206	240	340	200	200	200	70	2	3
	300	525.5	306	340	440	400	200	300	20	3	4
	400	625.5	406	440	540	400	200	400	70	3	5
	500	725.5	506	540	640	600	200	500	20	4	6
	600	825.5	606	640	740	600	200	600	70	4	7
	800	1,025.5	806	840	940	800	200	800	70	5	9

Size	B1	B2	B3 ±0.1	B4	B5 ±0.04	B6 ±0.1	B7	B8	B9	B10	B11	D1 ∅ h7	D2 ∅ g7	D3 ∅	D4 ∅
33	60	40	36	30	30	25	8.5	37.4	8.9	23	30	8	38	34	5.5
46	86	48	36	46	46	42	10	54.4	10	46	46	10	38	34	6.6

Size	D5 ∅	D6	D7 ∅ H7	D8	D9	D10	D11	H1	H3	H4	H5 ±0.1	H6	H7	L2	
															S
33	9.5	M5	4	M5	M2.6	M2	M3	43	20	23	29	33	5	107	94.3
46	11	M6	5	M5	M2.6	M2	M4	60	29	32	29	46	8	140	123.5

Size	L9	L10	L11	L12		L13		L14		L15		L16	L17	L18	L19
					S		S	±0.04	±0.1		S				
33	50	58	11	76	50.5	54	28.5	42	6	30	14.25	26	22	20	9
46	70	72.5	13	110	77	81	48	28	11	46	24	33.5	25	19.5	18

Size	L20 ±0.1	L21	L22 ±0.1	L24	T1	T2	T3	T4	T5	T6	T7	T8
33	51	2	4	100	5.4	6	2.5	10	3.5	5	6	2
46	65.5	2	6	100	6.5	9	2.5	10	4	5	8	2

# Electric slides EGSP

Ordering data – Modular products



Ordering table							
Size	20	26	33	46	Conditions	Code	Enter code
<b>M</b> Module No.	<b>562754</b>	<b>562755</b>	<b>562756</b>	<b>562757</b>			
Drive function	Electric slide drive, with caged balls					<b>EGSP</b>	EGSP
Size	20	26	33	46		-...	-...
Standard stroke for standard slide [mm]	25	-	-	-		-25	-...
	-	50	-	-		-50	-...
	75	-	-	-		-75	-...
	-	100	-	-		-100	-...
	125	-	-	-		-125	-...
	-	150	-	-		-150	-...
	-	200	-	-		-200	-...
	-	-	300	-		-300	-...
	-	-	400	-		-400	-...
	-	-	500	-		-500	-...
	-	-	600	-		-600	-...
	-	-	-	800		-800	-...
	Standard stroke for slide, short [mm]	-	-	130	-		-130
-		-	230	-		-230	-...
-		-	-	240		-240	-...
-		-	330	-		-330	-...
-		-	-	340		-340	-...
-		-	430	-		-430	-...
-		-	-	440		-440	-...
-		-	530	-		-530	-...
-		-	-	540		-540	-...
-		-	630	-		-630	-...
-		-	-	640		-640	-...
Spindle pitch [mm]	1	-	-	-		-1P	-...
	-	2	-	-		-2P	-...
	6	-	-	-		-6P	-...
	-	-	10	-		-10P	-...
	20	-	20	-		-20P	-...
<b>O</b> Accuracy	Standard accuracy						
	Greater accuracy					-H	
	Precision accuracy				<b>1</b>	-P	
Slide design	Standard slide					-	
			Slide, short		<b>2</b>	-S	
Additional slide	No additional slide					-	
	Additional slide (additional slide Z in combination with slide design S also results in a short slide)				<b>3</b>	-Z	

- 1** P With size 46 not in combination with stroke for standard slide 800 and stroke for slide, short 840
- 2** S With size 33 not in combination with spindle pitch 20
- 3** Z With size 20 not in combination with stroke for standard slide 25  
With size 26 not in combination with stroke for standard slide 50  
With size 33 not in combination with stroke for standard slide 100

**Transfer order code**

**EGSP** -  -  -  -  -  -  -  -

# Electric slides EGSK/EGSP

Accessories

FESTO

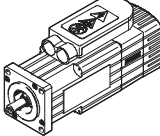
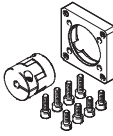
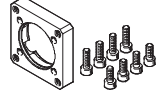
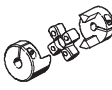
Permissible axis/motor combinations with axial kit – Without gear unit			Technical data → Internet: eamm-a
Motor	Axial kit	Axial kit consisting of:	
		Motor flange	Coupling
			
Type	Part No. Type	Part No. Type	Part No. Type
<b>EGSK-15</b>			
With stepper motor			
EMMS-ST-28-...	1703478 EAMM-A-P3-28D-28A	1087613 EAMF-A-28D-28A	562672 EAMC-16-20-3-5
<b>EGSK-20/EGSP-20</b>			
With servo motor			
EMMS-AS-40-...	562637 EAMM-A-P4-28B-40A	552163 EAMF-A-28B-40A	562673 EAMC-16-20-4-6
With stepper motor			
EMMS-ST-28-...	1731466 EAMM-A-P4-28B-28A	1704476 EAMF-A-28B-28A	562674 EAMC-16-20-4-5
EMMS-ST-42-...	562636 EAMM-A-P4-28B-42A	552164 EAMF-A-28B-42A	562674 EAMC-16-20-4-5
<b>EGSK-26/EGSP-26</b>			
With servo motor			
EMMS-AS-40-...	562641 EAMM-A-P5-28B-40A	552163 EAMF-A-28B-40A	543419 EAMC-16-20-5-6
With stepper motor			
EMMS-ST-28-...	1731474 EAMM-A-P5-28B-28A	1704476 EAMF-A-28B-28A	562676 EAMC-16-20-5-5
EMMS-ST-42-...	562640 EAMM-A-P5-28B-42A	552164 EAMF-A-28B-42A	562676 EAMC-16-20-5-5
<b>EGSK-33</b>			
With servo motor			
EMMS-AS-40-...	562646 EAMM-A-P6-38A-40A	562667 EAMF-A-38A-40A	558312 EAMC-30-32-6-6
EMMS-AS-55-...	562647 EAMM-A-P6-38A-55A	558176 EAMF-A-38A-55A	551003 EAMC-30-32-6-9
With stepper motor			
EMMS-ST-42-...	562644 EAMM-A-P6-38A-42A	562668 EAMF-A-38A-42A	561333 EAMC-30-32-5-6
EMMS-ST-57-...	562645 EAMM-A-P6-38A-57A	560692 EAMF-A-38A-57A	551002 EAMC-30-32-6-6.35

# Electric slides EGSK/EGSP

Accessories

FESTO

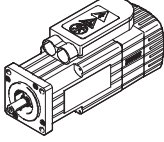
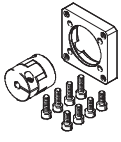
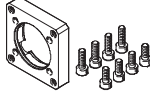
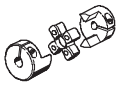
Permissible axis/motor combinations with axial kit – Without gear unit			Technical data → Internet: eamm-a
Motor	Axial kit	Axial kit consisting of:	
		Motor flange	Coupling
			
Type	Part No. Type	Part No. Type	Part No. Type
<b>EGSK-46/EGSP-33</b>			
With servo motor			
EMMS-AS-40-...	562652 EAMM-A-P8-38A-40A	562667 EAMF-A-38A-40A	533708 EAMC-30-32-6-8
EMMS-AS-55-...	562653 EAMM-A-P8-38A-55A	558176 EAMF-A-38A-55A	543423 EAMC-30-32-8-9
EMMS-AS-70-...	564996 EAMM-A-P8-38A-70A	558018 EAMF-A-38A-70A	551004 EAMC-30-32-8-11
With stepper motor			
EMMS-ST-42-...	562650 EAMM-A-P8-38A-42A	562668 EAMF-A-38A-42A	562678 EAMC-30-32-5-8
EMMS-ST-57-...	562651 EAMM-A-P8-38A-57A	560692 EAMF-A-38A-57A	543421 EAMC-30-32-6.35-8
EMMS-ST-87-...	564998 EAMM-A-P8-38A-87A	560693 EAMF-A-38A-87A	551004 EAMC-30-32-8-11
<b>EGSP-46</b>			
With servo motor			
EMMS-AS-55-...	562659 EAMM-A-P10-38A-55A	558176 EAMF-A-38A-55A	562680 EAMC-30-32-9-10
EMMS-AS-70-...	564997 EAMM-A-P10-38A-70A	558018 EAMF-A-38A-70A	565008 EAMC-30-32-10-11
With stepper motor			
EMMS-ST-57-...	562658 EAMM-A-P10-38A-57A	560692 EAMF-A-38A-57A	562679 EAMC-30-32-6.35-10
EMMS-ST-87-...	564999 EAMM-A-P10-38A-87A	560693 EAMF-A-38A-87A	565008 EAMC-30-32-10-11

# Electric slides EGSK/EGSP

Accessories

## Cross connecting kit EHAM

Materials:

Adapter plate: Anodised aluminium

Screws, locating pins: Steel

Conforms to RoHS

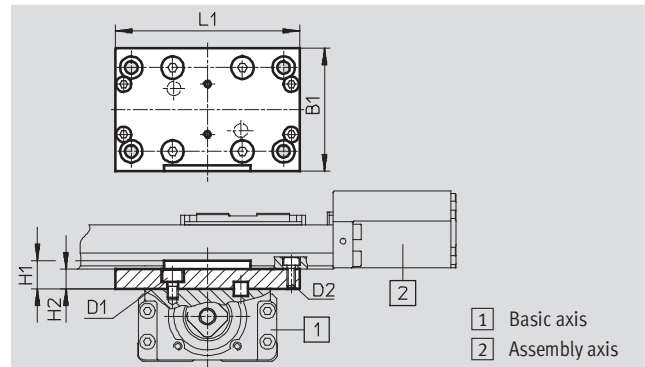

Dimensions and ordering data										
For size		B1	D1	D2	H1	H2	L1	Weight [g]	Part No.	Type
Basic axis	Assembly axis	±0.2					±0.2			
1	2									
20	15	33.2	M3	M3	7	5	56	27	563747	EHAM-S1-20-15
26	20	44	M4	M3	10	7	66	59	563748	EHAM-S1-26-20
33	26	54	M5	M4	12	9	86	124	563749	EHAM-S1-33-26
46	33	65	M6	M5	15	10	112	216	563750	EHAM-S1-46-33

# Electric slides EGSK/EGSP

Accessories



## Slide adapter EASA

Materials:

Adapter plate: Anodised aluminium

Screws, locating pins: Steel

Conforms to RoHS

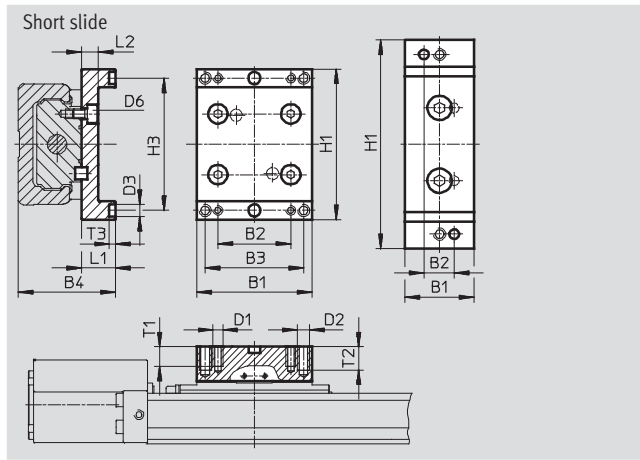

Dimensions and ordering data										
For size	B1	B2	B3	B4	D1	D2	D3	D6	H1	H3
	±0.2						∅ H7		±0.2	+0.04
With standard slide										
15	23	14	–	25	M3	–	4	M3	44	38
20	33.2	23	–	32	M3	–	2	M3	52	44.5
26	47.4	30	–	40	M4	–	5	M4	62	54.5
33	54	40	–	48	M5	–	4	M5	86	74
46	81	30	48	68	M5	M6	5	M6	112	100
With short slide										
33	28.5	12.5	–	48	M5	–	4	M5	86	74
46	48	22	–	68	M6	–	5	M6	112	100

For size	L1	L2	T1	T2	T3	Weight [g]	Part No.	Type
	+0.05				+0.1			
With standard slide								
15	10	5.4	6	–	2.5	20	562742	EASA-S1-15
20	12	6	6	–	2.5	38	562743	EASA-S1-20
26	14	7	8	–	2.5	74	562744	EASA-S1-26
33	15	9	15	–	2.6	130	562745	EASA-S1-33
46	22	10	10	12	2.6	310	562746	EASA-S1-46
With short slide								
33	15	9	15	–	2.6	70	562747	EASA-S1-33-S
46	22	10	12	–	2.6	180	562748	EASA-S1-46-S



# Electric slides EGSK/EGSP

Accessories

**Cover kit EASC**  
for standard slide

Materials:  
Cover profile, adapter plate, adapter:  
Anodised aluminium  
Screws, locating pins: Steel  
Conforms to RoHS

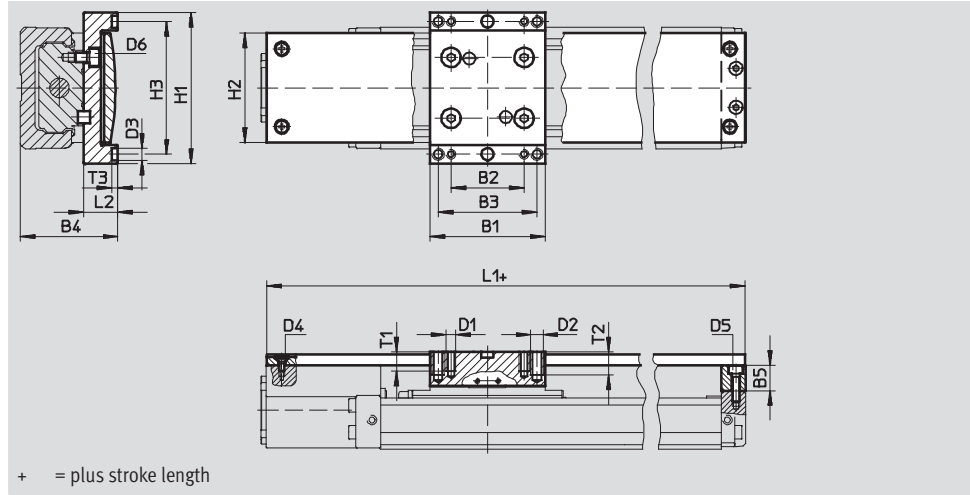

Dimensions										
For size	B1	B2	B3	B4	B5	D1	D2	D3	D4	D5
	±0.2							∅ H7		
15	23	14	–	25	6.5	M3	–	4	M2	M2
20	33.2	23		32	9	M3		2	M2.5	M2.5
26	47.4	30		40	10.5	M4		5	M2.5	M3
33	54	40		48	7	M5		4	M3	M3
46	81	30	48	68	10	M5	M6	5	M4	M4

For size	D6	H1	H2	H3	L1	L2	T1	T2	T3
		±0.2	±0.2	±0.04	–0.3				+0.1
15	M3	44	30	38	96.7	10	6	–	2.5
20	M3	52	35.6	44.5	126.2	12	6		2.5
26	M4	62	45	54.5	156.2	14	8		2.5
33	M5	86	62.5	74	168.2	15	15		2.6
46	M6	112	82.4	100	224.7	22	10	12	2.6

Ordering data									
For size	Stroke [mm]	Weight [g]	Part No.	Type	For size	Stroke [mm]	Weight [g]	Part No.	Type
15	25	51	562707	EASC-S1-15-25	33	100	327	562718	EASC-S1-33-100
	50	57	562708	EASC-S1-15-50		200	391	562719	EASC-S1-33-200
	75	62	562709	EASC-S1-15-75		300	454	562720	EASC-S1-33-300
	100	67	562710	EASC-S1-15-100		400	518	562721	EASC-S1-33-400
20	25	92	562711	EASC-S1-20-25		500	581	562722	EASC-S1-33-500
	75	107	562712	EASC-S1-20-75		600	645	562723	EASC-S1-33-600
	125	121	562713	EASC-S1-20-125	46	200	850	562724	EASC-S1-46-200
26	50	187	562714	EASC-S1-26-50		300	965	562725	EASC-S1-46-300
	100	211	562715	EASC-S1-26-100		400	1,080	562726	EASC-S1-46-400
	150	234	562716	EASC-S1-26-150		500	1,200	562727	EASC-S1-46-500
	200	258	562717	EASC-S1-26-200		600	1,310	562728	EASC-S1-46-600
						800	1,540	562729	EASC-S1-46-800

# Electric slides EGSK/EGSP

Accessories



**Cover kit EASC**  
for short slide

Materials:  
Cover profile, adapter plate, adapter:  
Anodised aluminium  
Screws, locating pins: Steel  
Conforms to RoHS

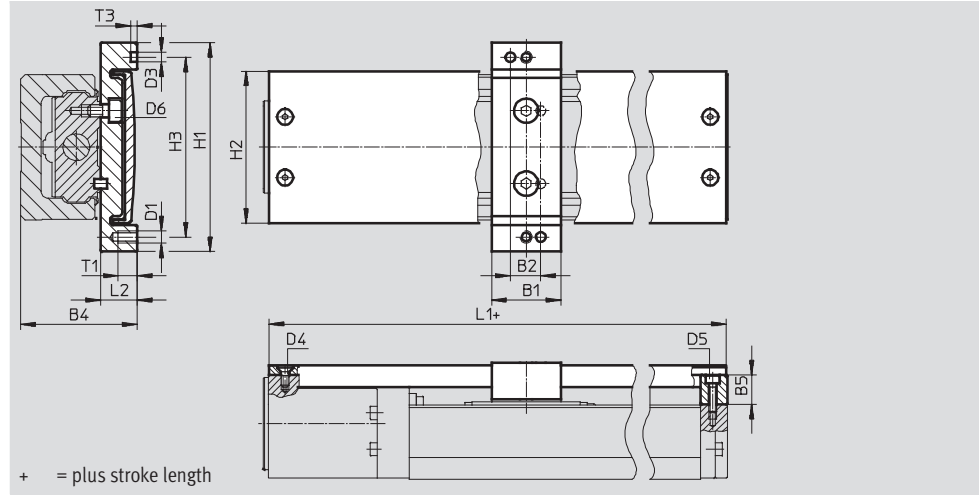

Dimensions								
For size	B1	B2	B4	B5	D1	D3	D4	D5
	±0.2	±0.04				∅ H7		
33	28.5	12.5	48	7	M5	4	M3	M3
46	48	22	68	10	M6	5	M4	M4

For size	D6	H1	H2	H3	L1	L2	T1	T3
		±0.2	±0.2	±0.04	-0.3			+0.1
33	M5	86	62.5	74	138.2	15	15	2.6
46	M6	112	82.4	100	184.7	22	12	2.6

Ordering data				
For size	Stroke [mm]	Weight [g]	Part No.	Type
33	130	263	562730	EASC-S1-33-130-S
	230	328	562731	EASC-S1-33-230-S
	330	391	562732	EASC-S1-33-330-S
	430	454	562733	EASC-S1-33-430-S
	530	518	562734	EASC-S1-33-530-S
	630	581	562735	EASC-S1-33-630-S
46	240	724	562736	EASC-S1-46-240-S
	340	840	562737	EASC-S1-46-340-S
	440	955	562738	EASC-S1-46-440-S
	540	1,070	562739	EASC-S1-46-540-S
	640	1,190	562740	EASC-S1-46-640-S
	840	1,420	562741	EASC-S1-46-840-S

# Electric slides EGSK/EGSP

Accessories

## Sensor rail EAPR

Materials:

Sensor bracket: Anodised aluminium

Switch lug, screws: Galvanised steel

Conforms to RoHS

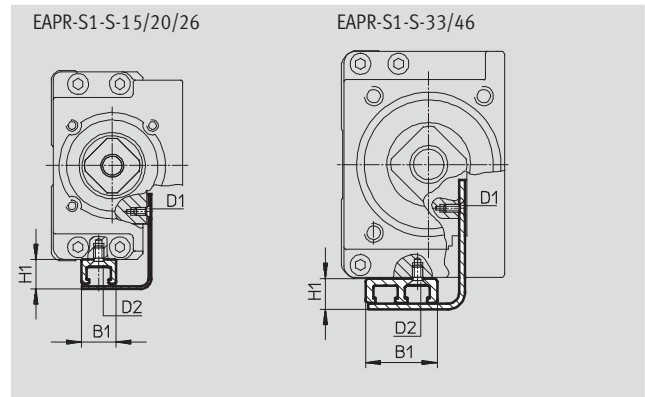

Dimensions						
For size	B1	H1		D1		D2
For type		EGSK	EGSP	EGSK	EGSP	
With standard slide						
15	9	8.5	-	M2	-	M2
20		7.75	7.75		M1.6	M2.5
26				M3	M2	
33	19	7.75	8.5	M2	M2	M2.5
46						
With short slide						
33	19	7.5	8.5	M2	M2	M2.5
46		8.5				

Ordering data					
For size	Stroke	Weight	Part No.	Type	
For type	[mm]	[g]			
With standard slide					
15	25	10	562611	EAPR-S1-S-15-25	
	50	12	562612	EAPR-S1-S-15-50	
	75	14	562613	EAPR-S1-S-15-75	
	100	16	562614	EAPR-S1-S-15-100	
20	25	14	562615	EAPR-S1-S-20-25	
	75	18	562616	EAPR-S1-S-20-75	
	125	22	562617	EAPR-S1-S-20-125	
26	50	24	562618	EAPR-S1-S-26-50	
	100	28	562619	EAPR-S1-S-26-100	
	150	32	562620	EAPR-S1-S-26-150	
	200	37	562621	EAPR-S1-S-26-200	
With standard slide or short slide					
33	100/130-S	51	562622	EAPR-S1-S-33-100/130-S	
	200/230-S	69	562623	EAPR-S1-S-33-200/230-S	
	300/330-S	88	562624	EAPR-S1-S-33-300/330-S	
	400/430-S	106	562625	EAPR-S1-S-33-400/430-S	
	500/530-S	125	562626	EAPR-S1-S-33-500/530-S	
	600/630-S	144	562627	EAPR-S1-S-33-600/630-S	
46	200/240-S	78	562628	EAPR-S1-S-46-200/240-S	
	300/340-S	97	562629	EAPR-S1-S-46-300/340-S	
	400/440-S	115	562630	EAPR-S1-S-46-400/440-S	
	500/540-S	134	562631	EAPR-S1-S-46-500/540-S	
	600/640-S	153	562632	EAPR-S1-S-46-600/640-S	
	800/840-S	190	562633	EAPR-S1-S-46-800/840-S	

# Electric slides EGSK/EGSP



Accessories

**FESTO**

Ordering data – Centring pins, centring sleeves					
	For size	Comment	Part No.	Type	PU <sup>1)</sup>
	15	For slide	189652	ZBH-5	10
	20		525273	ZBS-2	
	26, 46		150928	ZBS-5	
	33		562959	ZBS-4	
	15, 33	For slide adapter	562959	ZBS-4	
	20		525273	ZBS-2	
	26, 46		150928	ZBS-5	

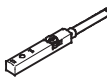
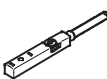
1) Packaging unit

Ordering data – Proximity sensors for T-slot, inductive					Technical data → Internet: sies	
	Type of mounting	Switching output	Electrical connection	Cable length [m]	Part No.	Type
<b>N/O contact</b>						
	Insertable in the slot from above, flush with the sensor rail	PNP	Cable, 3-wire	7.5	551386	SIES-8M-PS-24V-K-7,5-OE
			Plug M8x1, 3-pin	0.3	551387	SIES-8M-PS-24V-K-0,3-M8D
		NPN	Cable, 3-wire	7.5	551396	SIES-8M-NS-24V-K-7,5-OE
			Plug M8x1, 3-pin	0.3	551397	SIES-8M-NS-24V-K-0,3-M8D
<b>N/C contact</b>						
	Insertable in the slot from above, flush with the sensor rail	PNP	Cable, 3-wire	7.5	551391	SIES-8M-PO-24V-K-7,5-OE
			Plug M8x1, 3-pin	0.3	551392	SIES-8M-PO-24V-K-0,3-M8D
		NPN	Cable, 3-wire	7.5	551401	SIES-8M-NO-24V-K-7,5-OE
			Plug M8x1, 3-pin	0.3	551402	SIES-8M-NO-24V-K-0,3-M8D

Ordering data – Connecting cables				Technical data → Internet: nebu	
	Electrical connection, left	Electrical connection, right	Cable length [m]	Part No.	Type
	Straight socket, M8x1, 3-pin	Cable, open end, 3-wire	2.5	541333	NEBU-M8G3-K-2.5-LE3
			5	541334	NEBU-M8G3-K-5-LE3
	Angled socket, M8x1, 3-pin	Cable, open end, 3-wire	2.5	541338	NEBU-M8W3-K-2.5-LE3
			5	541341	NEBU-M8W3-K-5-LE3

# Product Range and Company Overview

## A Complete Suite of Automation Services

Our experienced engineers provide complete support at every stage of your development process, including: conceptualization, analysis, engineering, design, assembly, documentation, validation, and production.



**Custom Automation Components**  
Complete custom engineered solutions



**Custom Control Cabinets**  
Comprehensive engineering support and on-site services



**Complete Systems**  
Shipment, stocking and storage services

## The Broadest Range of Automation Components

With a comprehensive line of more than 30,000 automation components, Festo is capable of solving the most complex automation requirements.



**Electromechanical**  
Electromechanical actuators, motors, controllers & drives



**Pneumatics**  
Pneumatic linear and rotary actuators, valves, and air supply



**PLCs and I/O Devices**  
PLC's, operator interfaces, sensors and I/O devices

## Supporting Advanced Automation... As No One Else Can!

Festo is a leading global manufacturer of pneumatic and electromechanical systems, components and controls for industrial automation, with more than 12,000 employees in 56 national headquarters serving more than 180 countries. For more than 80 years, Festo has continuously elevated the state of manufacturing with innovations and optimized motion control solutions that deliver higher performing, more profitable automated manufacturing and processing equipment. Our dedication to the advancement of automation extends beyond technology to the education and development of current and future automation and robotics designers with simulation tools, teaching programs, and on-site services.

## Quality Assurance, ISO 9001 and ISO 14001 Certifications

Festo Corporation is committed to supply all Festo products and services that will meet or exceed our customers' requirements in product quality, delivery, customer service and satisfaction.

To meet this commitment, we strive to ensure a consistent, integrated, and systematic approach to management that will meet or exceed the requirements of the ISO 9001 standard for Quality Management and the ISO 14001 standard for Environmental Management.



© Copyright 2008, Festo Corporation. While every effort is made to ensure that all dimensions and specifications are correct, Festo cannot guarantee that publications are completely free of any error, in particular typing or printing errors. Accordingly, Festo cannot be held responsible for the same. For Liability and Warranty conditions, refer to our "Terms and Conditions of Sale", available from your local Festo office. All rights reserved. No part of this publication may be reproduced, distributed, or transmitted in any form or by any means, electronic, mechanical, photocopying or otherwise, without the prior written permission of Festo. All technical data subject to change according to technical update.



Printed on recycled paper at New Horizon Graphic, Inc., FSC certified as an environmentally friendly printing plant.

# Festo North America

## Festo Regional Contact Center

5300 Explorer Drive  
Mississauga, Ontario L4W 5G4  
Canada

### USA Customers:

For ordering assistance,

**Call:** 1.800.99.FESTO (1.800.993.3786)

**Fax:** 1.800.96.FESTO (1.800.963.3786)

**Email:** [customer.service@us.festo.com](mailto:customer.service@us.festo.com)

For technical support,

**Call:** 1.866.GO.FESTO (1.866.463.3786)

**Fax:** 1.800.96.FESTO (1.800.963.3786)

**Email:** [product.support@us.festo.com](mailto:product.support@us.festo.com)

### Canadian Customers:

**Call:** 1.877.GO.FESTO (1.877.463.3786)

**Fax:** 1.877.FX.FESTO (1.877.393.3786)

**Email:** [festo.canada@ca.festo.com](mailto:festo.canada@ca.festo.com)

---

## USA Headquarters

Festo Corporation  
395 Moreland Road  
P.O. Box 18023  
Hauppauge, NY 11788, USA  
[www.festo.com/us](http://www.festo.com/us)

---

## USA Sales Offices

### Appleton

North 922 Tower View Drive, Suite N  
Greenville, WI 54942, USA

### Boston

120 Presidential Way, Suite 330  
Woburn, MA 01801, USA

### Chicago

1441 East Business Center Drive  
Mt. Prospect, IL 60056, USA

### Dallas

1825 Lakeway Drive, Suite 600  
Lewisville, TX 75057, USA

### Detroit – Automotive Engineering Center

2601 Cambridge Court, Suite 320  
Auburn Hills, MI 48326, USA

### New York

395 Moreland Road  
Hauppauge, NY 11788, USA

### Silicon Valley

4935 Southfront Road, Suite F  
Livermore, CA 94550, USA

## United States



**USA Headquarters, East:** Festo Corp., 395 Moreland Road, Hauppauge, NY 11788

Phone: 1.631.435.0800; Fax: 1.631.435.8026;

Email: [info@festo-usa.com](mailto:info@festo-usa.com)

[www.festo.com/us](http://www.festo.com/us)

## Canada



**Headquarters:** Festo Inc., 5300 Explorer Drive, Mississauga, Ontario L4W 5G4

Phone: 1.905.624.9000; Fax: 1.905.624.9001;

Email: [festo.canada@ca.festo.com](mailto:festo.canada@ca.festo.com)

[www.festo.ca](http://www.festo.ca)

## Mexico



**Headquarters:** Festo Pneumatic, S.A., Av. Ceylán 3, Col. Tequesquahuac,  
54020 Tlalneantla, Edo. de México

Phone: 011 52 [55] 53 21 66 00; Fax: 011 52 [55] 53 21 66 65;

Email: [festo.mexico@mx.festo.com](mailto:festo.mexico@mx.festo.com)

[www.festo.com/mx](http://www.festo.com/mx)

---

## Central USA

Festo Corporation  
1441 East Business  
Center Drive  
Mt. Prospect, IL 60056, USA  
Phone: 1.847.759.2600  
Fax: 1.847.768.9480



## Western USA

Festo Corporation  
4935 Southfront Road,  
Suite F  
Livermore, CA 94550, USA  
Phone: 1.925.371.1099  
Fax: 1.925.245.1286



---

## Festo Worldwide

Argentina Australia Austria Belarus Belgium Brazil Bulgaria Canada Chile China Colombia Croatia Czech Republic Denmark  
Estonia Finland France Germany Great Britain Greece Hong Kong Hungary India Indonesia Iran Ireland Israel Italy Japan Latvia  
Lithuania Malaysia Mexico Netherlands New Zealand Norway Peru Philippines Poland Romania Russia Serbia Singapore  
Slovakia Slovenia South Africa South Korea Spain Sweden Switzerland Taiwan Thailand Turkey Ukraine United States Venezuela

[www.festo.com](http://www.festo.com)