

Semi-rotary drives DRQD/DRQD-B, twin pistons

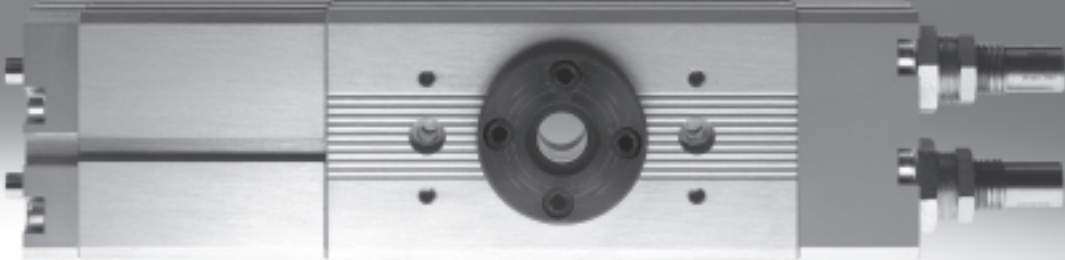

# Semi-rotary drives DRQD/DRQD-B, twin pistons

Key features



## General

- Rack and pinion principle
- High accuracy
- Extremely good rigidity
- Backlash-free and dynamic
- Piston  $\varnothing$  6 ... 50 mm
- Torque 0.16 ... 50 Nm
- Swivel angle 0 ... 360°
- Defined interfaces
- End-position adjustment -60 ... +6°
- End-position adjustment with end-position cushioning P1J -320 ... +6°
- Choice of mounting options
- Supply port at one end
- Ideal for use in handling applications

## Wide choice of variants

### Spigot shaft



- Piston  $\varnothing$  6 ... 50 mm

### Flanged shaft



- Piston  $\varnothing$  6 ... 50 mm

### Adjustable end-position cushioning

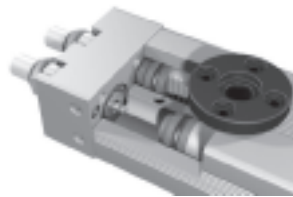

- Piston  $\varnothing$  16 ... 50 mm
- PPVJ – pneumatic, adjustable
- YSRJ – hydraulic shock absorber, self-adjusting
- Piston  $\varnothing$  16 ... 32 mm
- P1J – flexible cushioning elements, adjustable

### Intermediate position

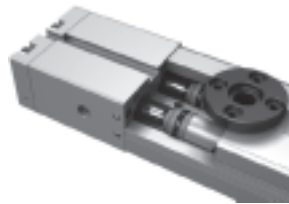

- Piston  $\varnothing$  16 ... 50 mm
- Allows positioning of the drive shaft in a mid-position

### Position sensing



- Piston  $\varnothing$  6 ... 50 mm
- For piston  $\varnothing$  6 ... 12 mm: proximity sensor SME/SMT-10
- For piston  $\varnothing$  16 ... 50 mm: proximity sensor SME/SMT-8

### Adapter kits for grippers and drive combinations



- Piston  $\varnothing$  6 ... 50 mm

### Energy through-feed



- Piston  $\varnothing$  6 ... 50 mm
- Simple and space-saving installation of tubing through the hollow flanged shaft
- DRQD-...-SD...  
1 ... 4 DUO tubes



- Piston  $\varnothing$  16 ... 50 mm
- Simple and space-saving installation of tubing and cables through the hollow flanged shaft
- DRQD-...-E...  
1 ... 2 DUO tubes and  
2 ... 4 electrical cables

### Mounting options

#### using through holes

#### via thread in housing profile

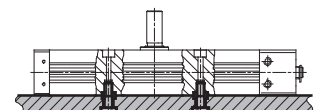
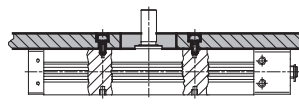
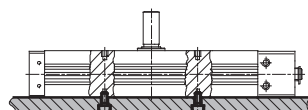
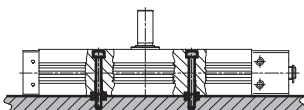

# Semi-rotary drives DRQD/DRQD-B, twin pistons

System example

System product for handling and assembly technology

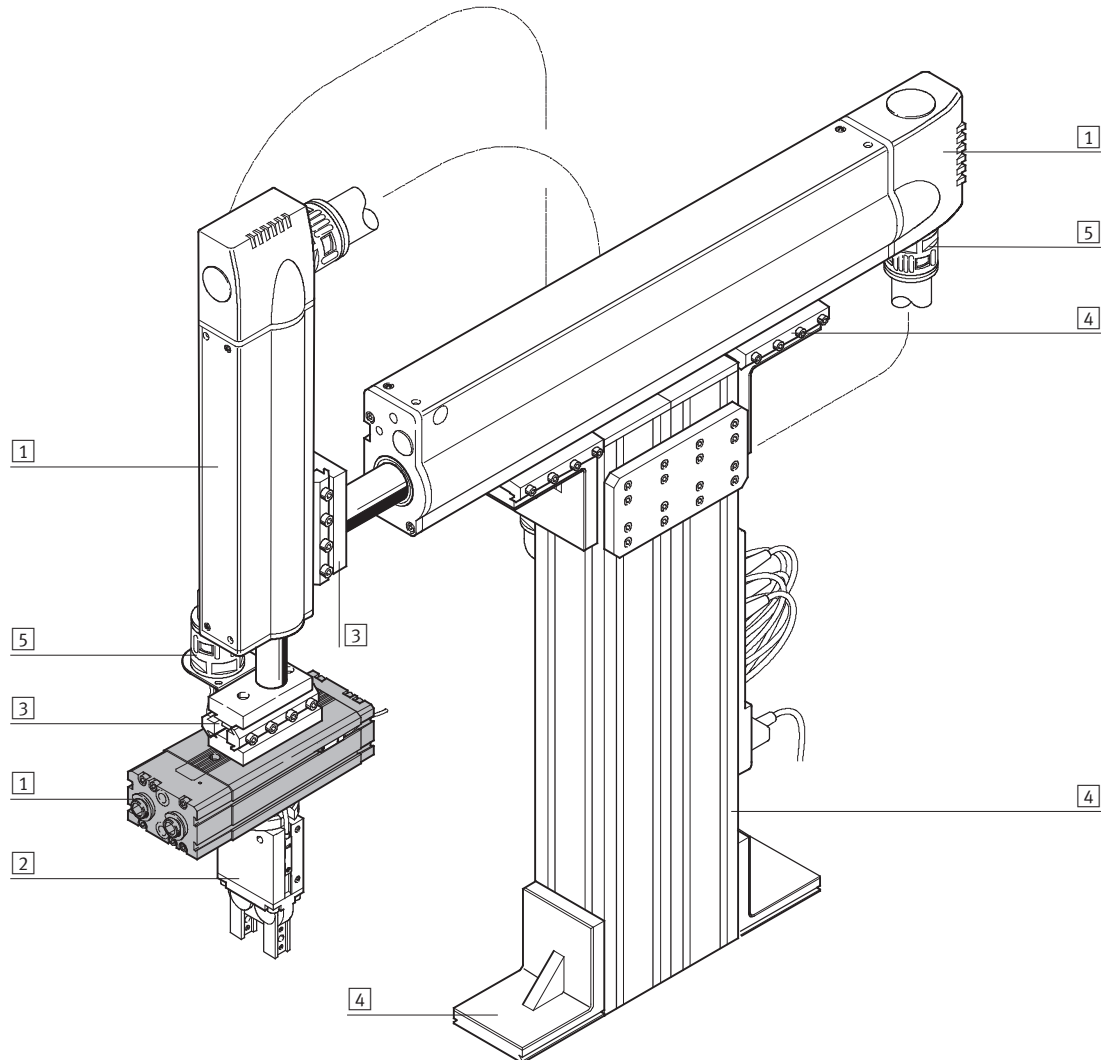

System elements and accessories		
	Brief description	→ Page/Internet
1	Drive units	Wide range of combination options within handling and assembly technology drive
2	Grippers	Wide range of combination options within handling and assembly technology gripper
3	Adapters	For drive/drive and drive/gripper combinations adapter kit
4	Basic mounting components	Profiles and profile connectors as well as profile/drive connectors basic component
5	Installation components	For achieving a clear-cut, safe layout for electrical cables and tubing installation component
-	Axes	Wide range of combination options within handling and assembly technology axes
-	Motors	Servo and stepper motors, with or without gearing motor

# Semi-rotary drives DRQD/DRQD-B, twin pistons

Product range overview

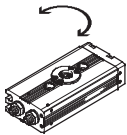
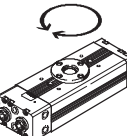
Function	Version	Type	Piston Ø [mm]	Swivel angle [°]	Adjustable end-position range [°]	Position sensing	End-position adjustment with flexible buffers in the end positions J...
						A	
Double-actin g	Basic version						
		DRQD	6, 8, 12	90	-20 ... +6	■	■
				180	-60 ... +6		
		DRQD-B	16, 20, 25, 32	90	-20 ... +6	■	-
				180	-320 ... +6		
				360			
0 ... 340							
	DRQD	40, 50	90	-20 ... +6	■	-	
			180				
			360				
			0 ... 340				

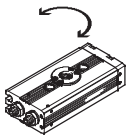
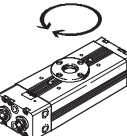
Function	Version	Type	Piston Ø [mm]	Output shaft		
				Spigot shaft	Flanged shaft	Integrated adapter for direct mounting of grippers A...
				ZW	FW	
Double-actin g	Basic version					
		DRQD	6, 8, 12	■	■	■
		DRQD-B	16, 20, 25, 32	■	■	-
	DRQD	40, 50	■	■	-	

# Semi-rotary drives DRQD/DRQD-B, twin pistons

Product range overview

Type	Piston Ø [mm]	Type of cushioning			Pneumatic connection	
		Pneumatic cushioning, adjustable PPV)	Flexible cushioning elements, adjustable P1)	Hydraulic shock absorber, self-adjusting YSR)	left AL	right AR
<b>Basic version</b>						
DRQD	6, 8, 12	-	-	-	-	■
DRQD-B	16, 20, 25, 32	■	■	■	■	■
DRQD	40, 50	■	-	■	■	■

Type	Piston Ø [mm]	Intermediate position	Energy through-feed	Adapter kits for grippers	→ Page/Internet
		Z1	SD..., E...		
<b>Basic version</b>					
DRQD	6, 8, 12	-	■	■	6
DRQD-B	16, 20, 25, 32	■	■	■	22
DRQD	40, 50	■	■	■	22

# Semi-rotary drives DRQD-6 ... 12, twin-pistons

Peripherals overview

FESTO

Piston  $\varnothing$  6 ... 12

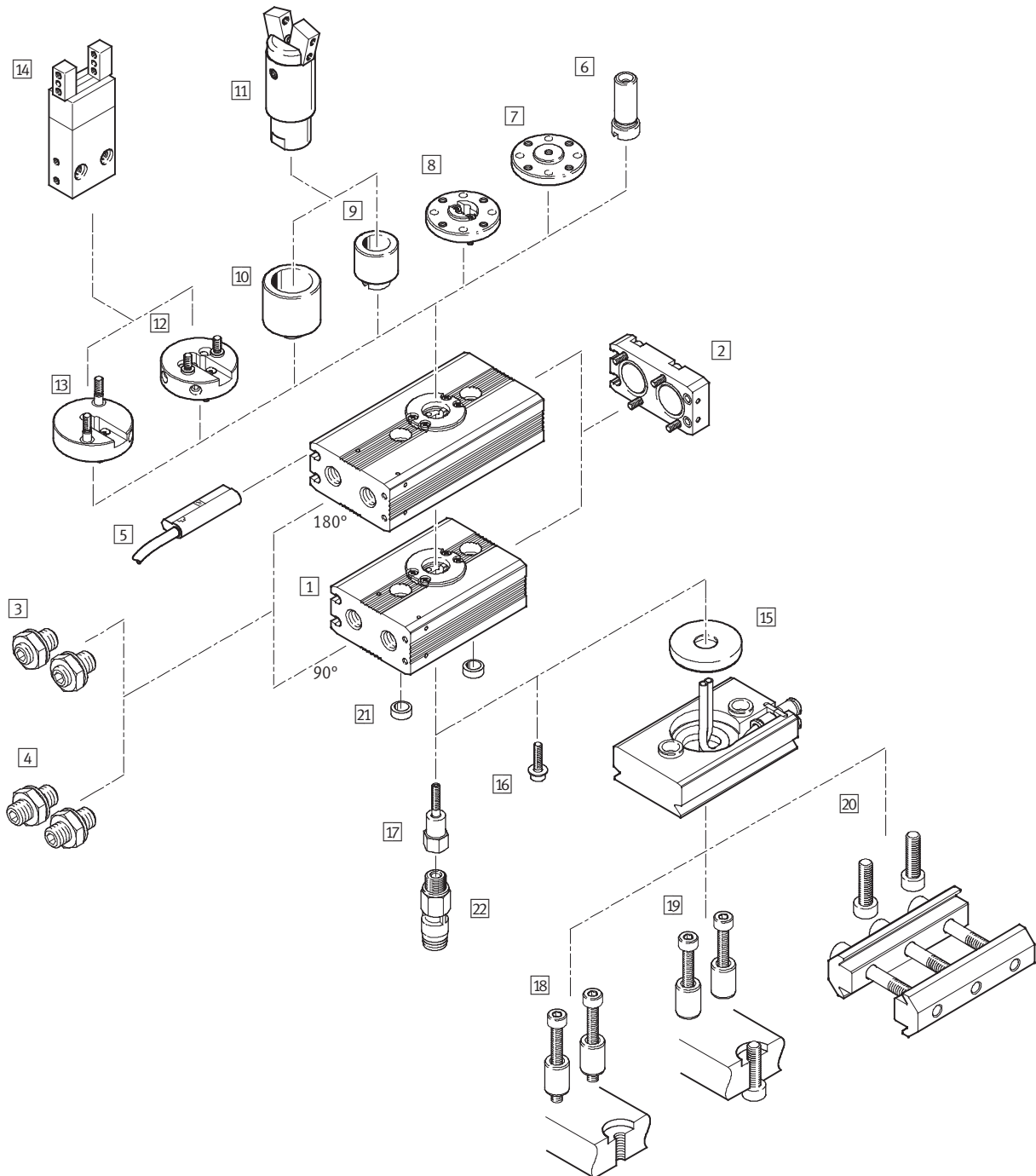

# Semi-rotary drives DRQD-6 ... 12, twin-pistons

Peripherals overview

FESTO

Variants, mounting attachments and accessories						
	Brief description	Piston Ø			→ Page/Internet	
		6	8	12		
1	Centre section	Centre section for 90° or 180° swivel angle	■	■	■	9
2	Connector cap	With integrated compressed air directional function	■	■	■	
3	End-position adjustment J20	Flexible end position cushioning with adjustable end positions (-20 ... +6°)	■	■	■	
4	End-position adjustment J60	Flexible end position cushioning with adjustable end positions (-60 ... +6°)	■	■	■	
5	Position sensing A	Contactless via proximity sensors SME-/SMT-10	■	■	■	65
6	Spigot shaft ZW <sup>1)</sup>	Hollow with woodruff key	■	■	■	9
7	Flanged shaft FW <sup>1)</sup>	Hollow	■	■	■	
8	Flanged shaft FW-SD32	Hollow, for energy through-feed	-	■	■	
9	Adapters A08 <sup>2)</sup>	For grippers HGWM-08-...-G8 and HGPM-08-...-G8	■	■	■	
10	Adapters A12 <sup>2)</sup>	For grippers HGWM-12-...-G8 and HGPM-12-...-G8	■	■	■	
11	Grippers HGPM/HGWM	HGPM-...-G8 and HGWM-...-G8	■	■	■	
12	Adapters AS1	For grippers DHPS-06-A, DHRS-10-A and DHWS-10-A	-	■	■	9
13	Adapters AS2	For grippers DHDS-16-A	-	■	■	
14	Grippers DHPS/DHDS/DHRS/DHWS	DHPS-06-A, DHDS-16-A, DHRS-10-A, DHWS-10-A	-	■	■	gripper
15	Energy through-feed SD32	2 tubes with O.D. 3 mm	-	■	■	14
16	Socket head screw ZS	Mounting of ZW and FW	■	■	■	9
17	Hollow bolt HS	Mounting of ZW, FW, A08, A12 and air supply for attachments	■	■	■	
18	Type of mounting B1	For connection of DRQD/FW-SD32: Locking screws in centring sleeves	■	■	■	
19	Type of mounting B2	For connection of DRQD/FW-SD32: Through screws in attachment	■	■	■	
20	Type of mounting B3	For connection of DRQD/FW-SD32: Clamping via profile, grid 40 mm	■	■	■	
21	Centring sleeve ZBH	For centring (2 pieces included in scope of delivery for DRQD)	■	■	■	14
22	Rotary push-in fitting <sup>3)</sup> QS	Quick Star push-in fittings, rotatable with ball bearing	■	■	■	

1) The socket head screw ZS is included in the scope of delivery. The hollow bolt HS must be ordered separately

2) Only in conjunction with hollow bolt HS. The hollow bolt HS must be ordered separately

3) For energy through-feed in combination with HS

# Semi-rotary drives DRQD-6 ... 12, twin-pistons

Type codes

DRQD – 6 – 180 – J60 – A – A12 – – HS – B2 – B

Type	
Double-acting	
DRQD	Semi-rotary drive

Piston Ø [mm]	6
---------------	---

Swivel angle [°]	180
------------------	-----

End-position adjustment [°]	
J20	-20 ... +6
J60	-60 ... +6

Position sensing	
A	For proximity sensing

Output shaft/adaptor	
ZW	Spigot shaft
FW	Flanged shaft
A08	Adapter for micro, angle and parallel grippers
A12	
AS1	Adapter for parallel, three-point, angle and radial grippers
AS2	

Energy through-feed	
SD32	2 tubes with O.D. 3 mm

Type of screw	
ZS	Socket head screw
HS	Hollow bolt

Type of mounting	
B1	Locking screws in centring sleeves
B2	Through screws in attachment
B3	Clamping via profile, 40 mm

User's manual	
	German
E	English
F	French
S	Spanish
I	Italian
V	Swedish
B	Express waiver – no user manual to be included (already available)



# Semi-rotary drives DRQD-6 ... 12, twin-pistons

Technical data

Function



⊘ Diameter  
6 ... 12 mm

≡ Force  
0.16 ... 0.76 Nm

Variants

- 90° and 180° swivel angle
- Spigot or flanged shaft
- Adapters for grippers
- End-position adjustment
- Position sensing
- Energy through-feed
- Different types of mounting

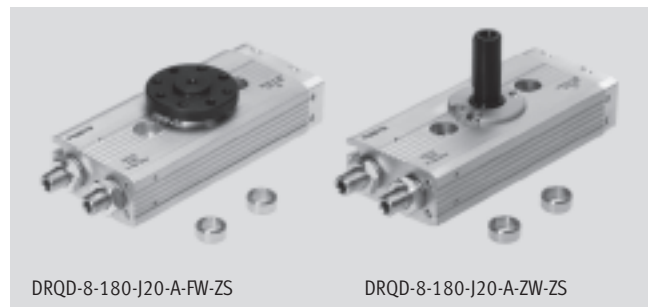

DRQD-8-180-J20-A-FW-ZS

DRQD-8-180-J20-A-ZW-ZS

www.festo.com/en/  
Spare\_parts\_service

General technical data		6	8	12
Piston ∅		6	8	12
Pneumatic connection		M3		
	HS	M5		
	SD32	-		QS...-3 for tube O.D. 3 mm
Constructional design	Semi-rotary drive with twin pistons based on the rack and pinion principle			
Cushioning	Flexible buffer at both ends			
Position sensing	For proximity sensing			
Type of mounting	Via through-hole			
	Via female thread			
Assembly position	Any			

Operating and environmental conditions		6	8	12
Piston ∅		6	8	12
Operating medium		Compressed air in accordance with ISO 8573-1:2010 [7:-:-]		
Operating pressure [bar]		1 ... 8		
	SD32	-	1.5 ... 8	-
Adjustable end-position range per end position [°]	J20	-20 ... +6		
	J60	-60 ... +6		
Max. permissible swivelling frequency at 6 bar (for completed cycle of motion) [Hz]	90°	5	4	3
	180°	3.5	2.5	2
	SD32	-		
Repetition accuracy [°]		< 0.2		
Ambient temperature <sup>1)</sup> [°C]		-10 ... +60		
Corrosion resistance class CRC <sup>2)</sup>		1		
ATEX		Specified types → www.festo.com		

1) Note operating range of proximity sensors

2) Corrosion resistance class 1 according to Festo standard 940 070

Components requiring low corrosion resistance. Transport and storage protection. Parts that do not have primarily decorative surface requirements, e.g. in internal areas that are not visible or behind covers

## Semi-rotary drives DRQD-6 ... 12, twin-pistons

FESTO

Technical data

Forces and torques				
Piston $\varnothing$		6	8	12
Theoretical torque [Nm] at 6 bar		0.16	0.33	0.76
	SD32	-	0.28	0.72
		Note: If torque acts against the direction of rotation in the end position, a drive with a rating of twice the maximum theoretical torque should be selected.		
Max. permissible radial and axial forces		Diagrams → 13		
Max. permissible mass moment of inertia [kgm <sup>2</sup> ]		$0.075 \times 10^{-4}$	$0.25 \times 10^{-4}$	$0.7 \times 10^{-4}$
	The data applies to the variants ZW, FW, A... without grippers, unthrottled.			

Weights [g]					
Piston $\varnothing$		6	8	12	
Centre section	90°	J20	66	90	145
		J60	67	92	148
	180°	J20	82	111	177
		J60	83	113	180
Output shaft	ZW	2	4		
	FW	4	7		
Adapters	A08	6	11		
	A12	6	11		
	AS1	-	13		
	AS2	-	15		
Screws	ZS	1			
	HS	4		5	
Flanged shaft with energy through-feed	SD32	-	71		
Mounting in combination with SD32	B1	-	17		
	B2	-	17	18	
	B3	-	81		

# Semi-rotary drives DRQD-6 ... 12, twin-pistons

Technical data

## Materials

Sectional view

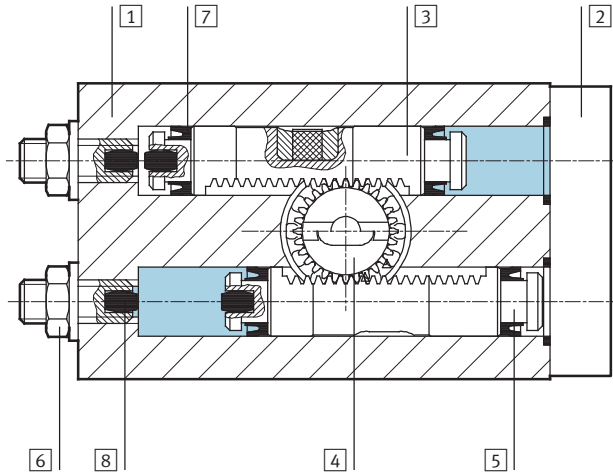

Piston Ø	6	8	12
1 Cylinder barrel (centre section)	Anodised aluminium		
2 Connector cap	Anodised aluminium		
3 Gear rack	Anodised aluminium		
4 Pinion	Stainless steel; milled teeth		
5 Piston	Anodised aluminium		
6 Threaded pin, hex nuts	Galvanised steel		
7 Piston seal	Nitrile rubber	Polyurethane	
8 Buffer for end-position cushioning	Nitrile rubber		
- DUO spiral tubing	Polyurethane		
- Woodruff key	Steel		
- Hollow bolt, centring sleeves	Stainless steel		
- Static seals	Steel, nitrile rubber		
- Material note	Copper, PTFE and silicone-free		

## Direction of rotation of the drive shaft

Pneumatic actuation of ports 1 or 2 produces a rotational movement in direction R1 or R2 respectively.

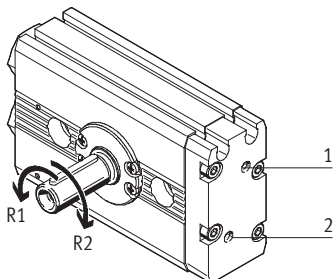

# Semi-rotary drives DRQD-6 ... 12, twin-pistons

Technical data

## Max. permissible radial and axial forces on the drive shaft

### Combined load

A semi-rotary drive DRQD-8-... is to be statically loaded with a radial force  $F_y = 60\text{ N}$ , which is at a distance of  $Z = 5\text{ mm}$  from the housing, and an

axial force  $F_{x, \text{push}} = 30\text{ N}$ , which is at a distance of  $V = 12\text{ mm}$  from the shaft (→ diagram of flanged shaft on right).

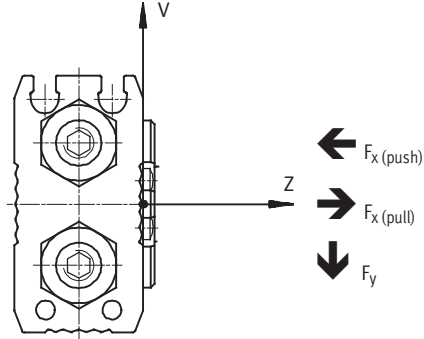

### Question:

Is it permissible to statically load a semi-rotary drive DRQD-8-... with these combined forces?

### Answer:

Graph 1 (→ 13) indicates that the maximum permissible radial force is  $F_{y, \text{max. (stat.)}}(5) = 193\text{ N}$  for a distance

$Z = 5\text{ mm}$ . Graph 3 (→ 13) indicates that the maximum axial force is

$F_{x, \text{push max. (stat.)}}(12) = 169\text{ N}$  for a distance  $V = 12\text{ mm}$ .

The following equation applies to combined loads:

$$\frac{F_y(z)}{F_{y, \text{max. (z)}}} + \frac{F_{x, \text{push}}(v)}{F_{x, \text{push, max. (v)}}} + \frac{F_{x, \text{pull}}(v)}{F_{x, \text{pull, max. (v)}}} \leq 1$$

The following values are assumed:

$F_y(5) = 60\text{ N}$   
 $F_{x, \text{push (stat.)}}(12) = 30\text{ N}$   
 $F_{y, \text{max. (stat.)}}(5) = 193\text{ N}$   
 $F_{x, \text{max. (stat.)}}(12) = 169\text{ N}$

With values inserted:

$$\frac{60\text{ N}}{193\text{ N}} + \frac{30\text{ N}}{169\text{ N}} \leq 1$$

$$0.311 + 0.178 \leq 1$$

$$0.489 \leq 1$$

Thus the drive may be statically loaded with the forces indicated above.

# Semi-rotary drives DRQD-6 ... 12, twin-pistons

Technical data

## Maximum static radial force

Graph 1

$$F_{y, \text{max. (stat.)}} = f(z)$$

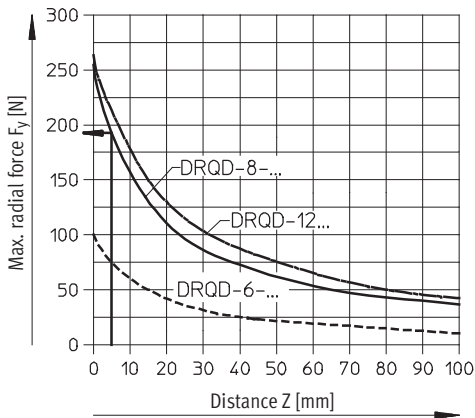

## Maximum dynamic radial force

Graph 2

$$F_{y, \text{max. (dyn.)}} = f(z)$$

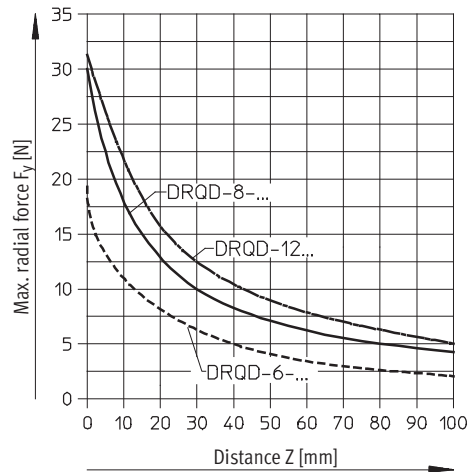

## Maximum static pull and push axial forces

Graph 3

$$F_{x, \text{max. (stat.)}} = f(v)$$

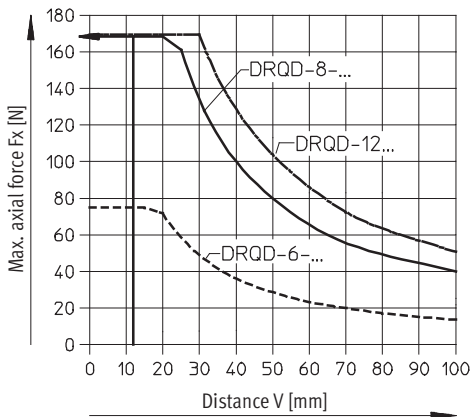

## Maximum dynamic pull and push axial forces

Graph 4

$$F_{x, \text{max. (dyn.)}} = f(v)$$

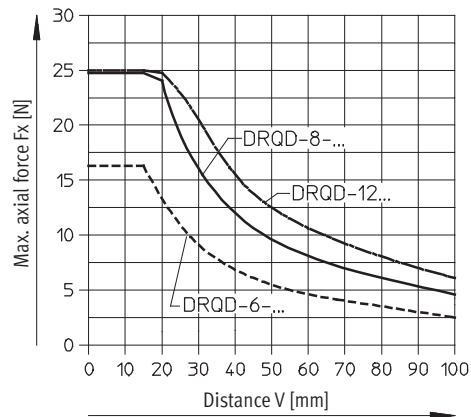

# Semi-rotary drives DRQD-6 ... 12, twin-pistons

Technical data

## Energy through-feed

The energy through-feed consists of DUO tubing (two lengths of tubing are fused together into a pair), whereby each tube has an O.D. of 3 mm. Compressed air is supplied via the

push-in fittings in the transfer plate. Only Quick-Star push-in fittings may be used to connect compressed air tubing to consuming devices (e.g. grippers).

## DRQD-...-SD...

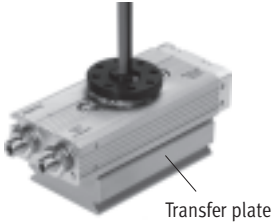

- For piston  $\varnothing$  8 ... 12
- Swivel angles of up to 180° are possible
- 1 DUO tube

Technical data		
Piston $\varnothing$		8   12
Number of spiral tubes		1 DUO tube
Standard nominal flow rate per tube	[l/min]	min. 70
Theoretical air consumption per tube at 6 bar	[cm <sup>3</sup> ]	5.3
Operating pressure as a function of ambient temperature	[bar]	0 ... 10 (at -10 ... +30 °C) 0 ... 9 (at +30 ... +40 °C) 0 ... 7.8 (at +40 ... +60 °)
Push-in fittings for connection to consuming device		QS...-3 for tube O.D. of 3 mm

# Semi-rotary drives DRQD-6 ... 12, twin-pistons

Technical data

## Dimensions

Download CAD Data → [www.festo.com/us/cad](http://www.festo.com/us/cad)

ZW – Spigot shaft

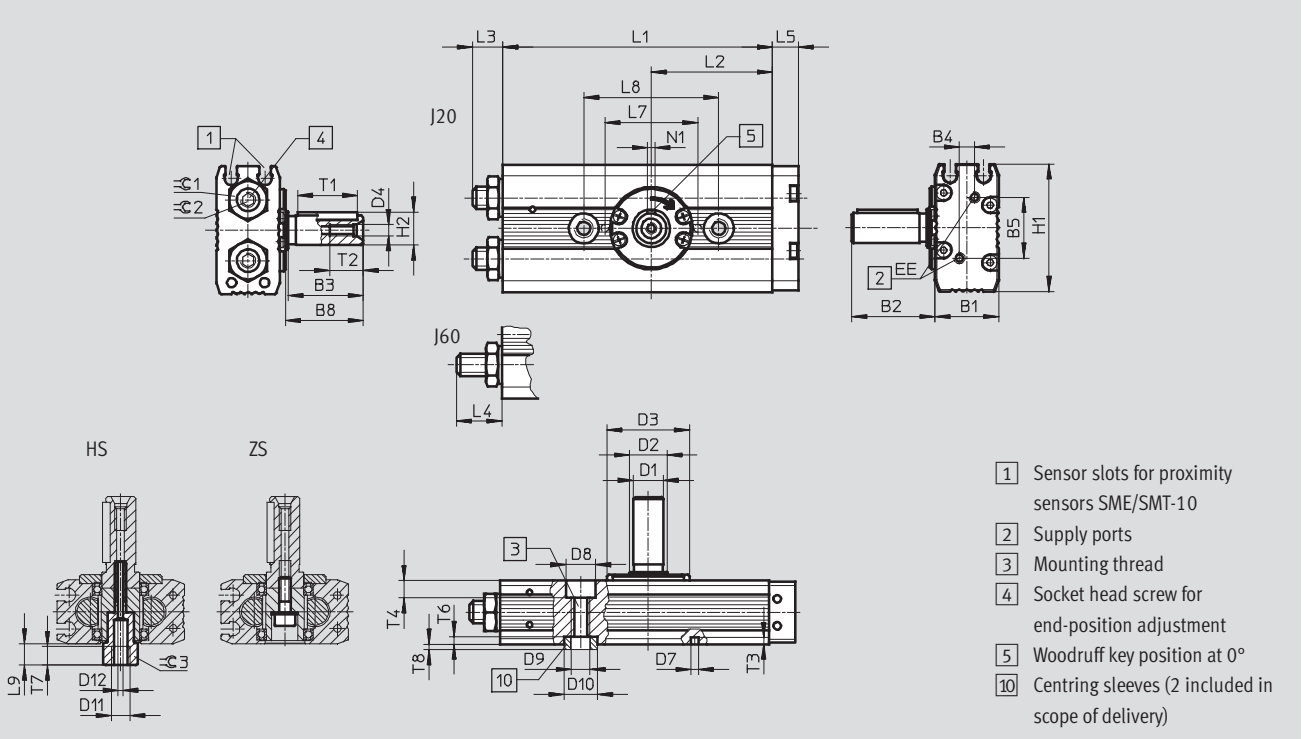

∅	Swivel angle	B1	B2	B3	B4	B5	B8	D1	D2	D3 <sup>1)</sup>	D4	D7	D8	D9	D10	D11	D12	EE	H1	H2
[mm]	[°]							∅ g7	∅ g6	∅ f7		∅ H8	∅ H8		∅ H7					
6	90	15.4	18.2	16	2	13.6	16.7	6	8	20	M2.5	2	6	M4	7	M5	1.3	M3	31	6.8
	180																			
8	90	17	22.2	20	4	16.2	20.7	8	10	22	M3	-	8	M5	9	M5	1.3	M3	34	8.8
	180																			
12	90	21	22.2	20	6	18.2	20.7	8	10	22	M3	-	8	M5	9	M5	1.3	M3	41	8.8
	180																			

∅	Swivel angle	L1	L2	L3	L4	L5	L7	L8	L9	N1	T1	T2	T3	T4	T6	T7	T8	≡C1	≡C2	≡C3
[mm]	[°]			max.	max.		±0.03	±0.03		P9										
6	90	46.7	20.2	7.1	11.1	7.5	20	30	6.2	2	12	7	1.8	3.4	1.6	5	1.4	8	2.5	8
	180	61.8	27.75																	
8	90	54.2	23.45	8.1	12.1	7	-	36	5.7	2	16	9	-	4.6	2	5	2	10	3	8
	180	71.8	32.25																	
12	90	59.2	25.95	9.1	13.1	8	-	36	5.7	2	16	9	-	4.6	2	5	2	13	4	8
	180	76.8	34.75																	

1) Centring possible with D3

# Semi-rotary drives DRQD-6 ... 12, twin-pistons

Technical data



## Dimensions

Download CAD Data → [www.festo.com/us/cad](http://www.festo.com/us/cad)

FW – Flanged shaft

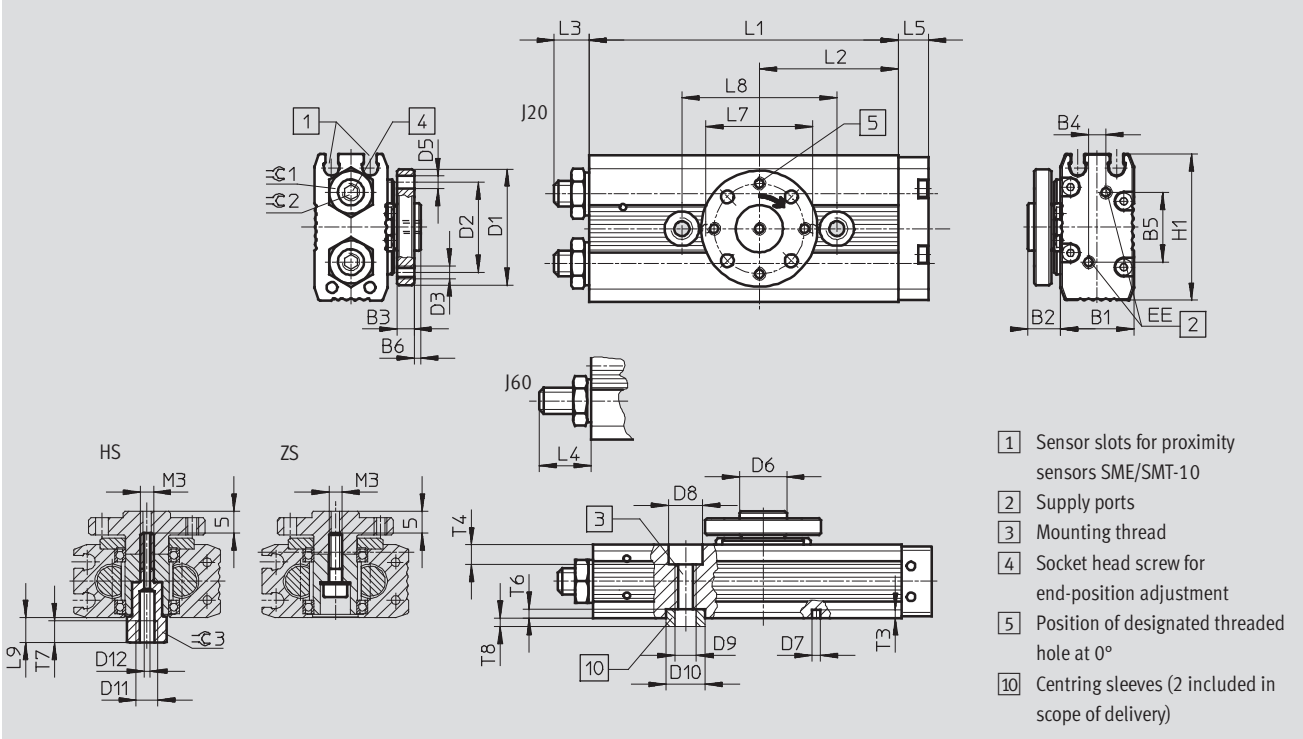

- 1 Sensor slots for proximity sensors SME/SMT-10
- 2 Supply ports
- 3 Mounting thread
- 4 Socket head screw for end-position adjustment
- 5 Position of designated threaded hole at 0°
- 10 Centring sleeves (2 included in scope of delivery)

∅ [mm]	Swivel angle [°]	B1	B2	B3	B4	B5	B6	D1 ∅	D2 ∅	D3	D5 ∅ H7	D6 ∅ g7	D7 ∅ H8	D8 ∅ H8	D9	D10 ∅ H7	D11	D12 ∅
6	90	15.4	7.7	4	2	13.6	1.5	23	16	M3	3	8	2	6	M4	7	M5	1.3
	180																	
8	90	17	7.7	4	4	16.2	1.5	27	21	M3	3	11	-	8	M5	9	M5	1.3
	180																	
12	90	21	7.7	4	6	18.2	1.5	27	21	M3	3	11	-	8	M5	9	M5	1.3
	180																	

∅ [mm]	Swivel angle [°]	EE	H1	L1	L2	L3	L4	L5	L7	L8	L9	T3	T4	T6	T7	T8	≡C1	≡C2	≡C3
6	90	M3	31	46.7	20.20	7.1	11.1	7.5	±0.03	±0.03	6.2	1.8	3.4	1.6	5	1.4	8	2.5	8
	180			61.8	27.75														
8	90	M3	34	54.2	23.45	8.1	12.1	7	-	36	5.7	-	4.6	2	5	2	10	3	8
	180			71.8	32.25														
12	90	M3	41	59.2	25.95	9.1	13.1	8	-	36	5.7	-	4.6	2	5	2	13	4	8
	180			76.8	34.75														



# Semi-rotary drives DRQD-6 ... 12, twin-pistons

Technical data

## Dimensions

Download CAD Data → [www.festo.com/us/cad](http://www.festo.com/us/cad)

FW-SD32 – Energy through-feed

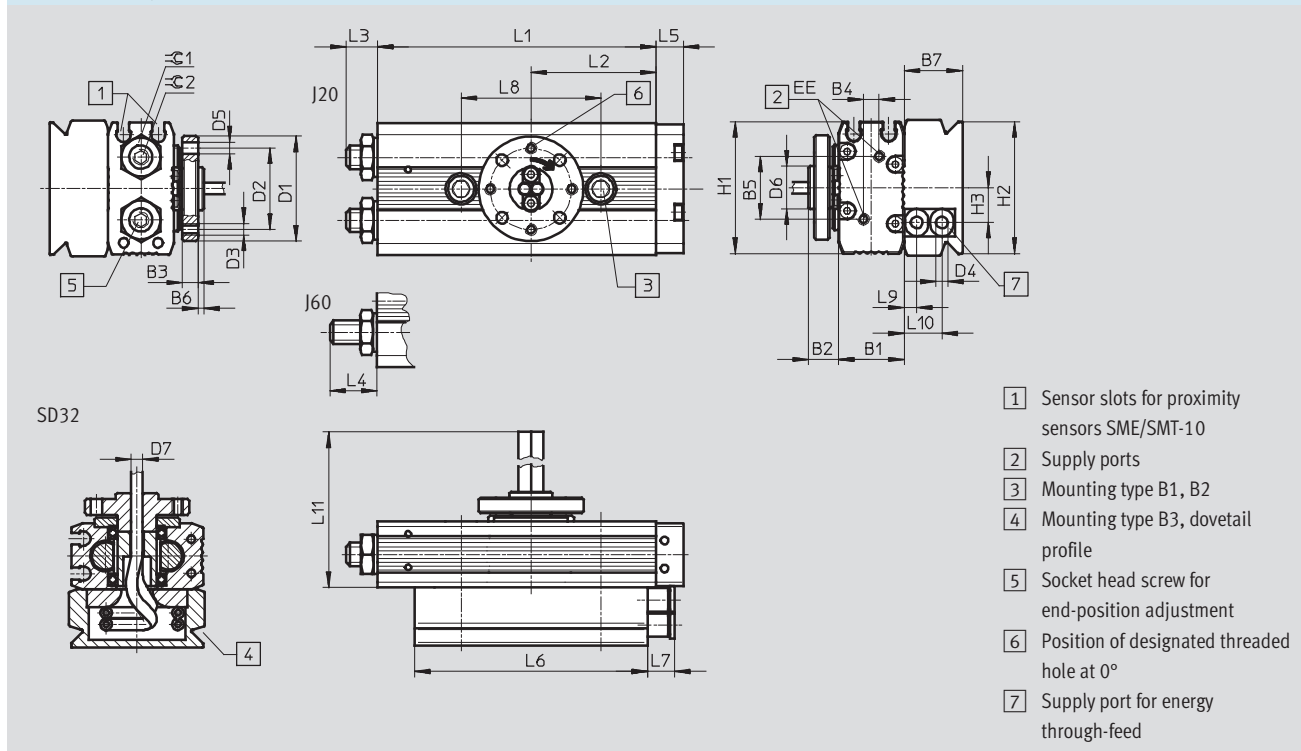

∅	Swivel angle [°]	B1	B2	B3	B4	B5	B6	B7	D1	D2	D3	D4	D5	D6	D7	EE
[mm]	[°]								∅	∅	∅	∅	∅	∅	∅	
8	90	17	7.7	4	4	16.2	1.5	15	27	21	M3	3	3	11	3	M3
	180															M3
12	90	21	7.7	4	6	18.2	1.5	15	27	21	M3	3	3	11	3	M3
	180															M3

∅	Swivel angle [°]	H1	H2	H3	L1	L2	L3	L4	L5	L6	L7	L8	L9	L10	L11	⊖1	⊖2
[mm]	[°]						max.	max.			±0.03						
8	90	34	35	9	54.2	23.45	8.1	12.1	7	60	7	36	3.2	9.7	292	10	3
	180				71.8	32.25											
12	90	41	35	9	59.2	25.95	9.1	13.1	8	60	7	36	3.2	9.7	292	13	4
	180				76.8	34.75											

# Semi-rotary drives DRQD-6 ... 12, twin-pistons

Technical data

**Dimensions – Mounting type** Download CAD Data → [www.festo.com/us/cad](http://www.festo.com/us/cad)

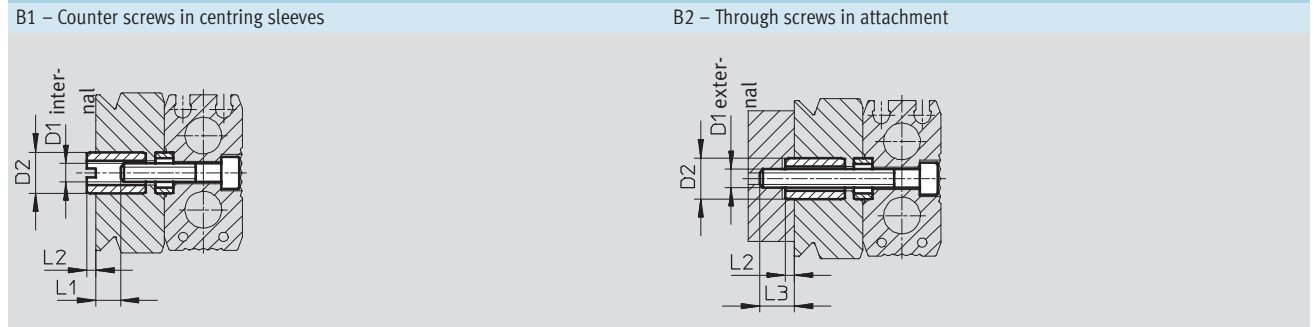

For Ø [mm]	Swivel angle [°]	D1	D2 Ø h7	L1	L2	L3
8	90	M4	9	4.9	2	8.2
	180					
12	90			5.9		9.2
	180					

**B3 – Clamping via profile**

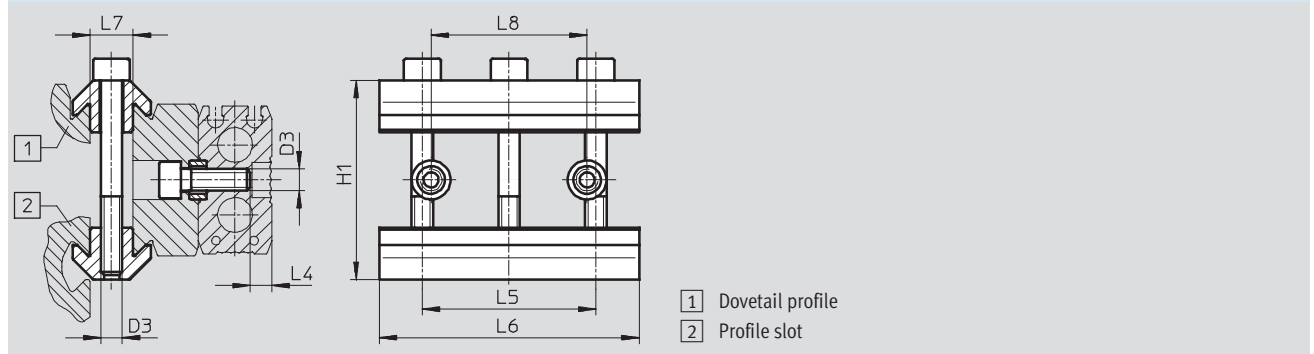

For Ø [mm]	Swivel angle [°]	D3	H1	L4	L5	L6	L7 +0.1	L8 ±0.03
8	90	M5	46	5	40	60	10	36
	180							
12	90			9				
	180							

# Semi-rotary drives DRQD-6 ... 12, twin-pistons

Technical data

## Dimensions – Adapter for gripper

Download CAD Data → [www.festo.com/us/cad](http://www.festo.com/us/cad)

### A08/A12

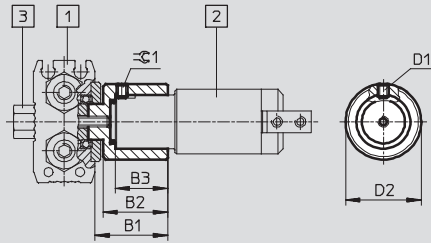

For adapter	1 Drive	2 Grippers	3 Type of screw	B1	B2	B3 ±0.03	D1	D2 ∅	∅C1
A08	DRQD-6-... DRQD-8-... DRQD-12-...	HGWM-08-...-G8 HGPM-08-...-G8	HS	15.2	13	9.6	M3	16	1.5
A12	DRQD-6-... DRQD-8-... DRQD-12-...	HGWM-12-...-G8 HGPM-12-...-G8	HS	20.2	18	14.6	M3	21	1.5

### AS1

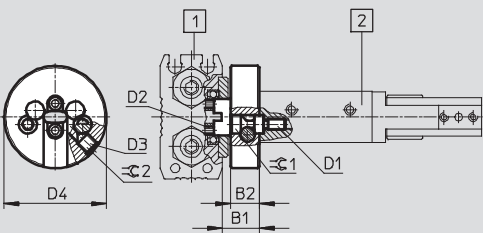

### AS2

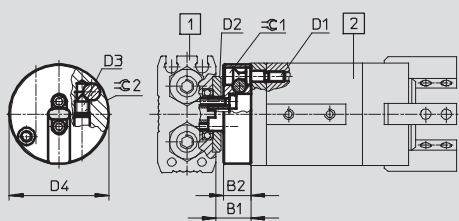

For adapter	1 Drive	2 Grippers	B1	B2	D1	D2	D3	D4 ∅	∅C1	∅C2
AS1	DRQD-8-... DRQD-12-...	DHPS-06-... DHRS-10-... DHWS-10-...	10.2	8	M3	M2	M4	28	2.5	2
AS2	DRQD-8-... DRQD-12-...	DHDS-16-...	10.2	8	M3	M2	M4	29	2.5	2

# Semi-rotary drives DRQD-6 ... 12, twin-pistons

Ordering data – Modular products

**M** Mandatory data →

Module No.	Function	Size	Swivel angle	End-position adjustment	Position sensing	Output shaft/adaptor
187 431	DRQD	6	90	J20	A	ZW
187 432		8	180	J60		FW
187 433		12				A08 A12 AS1 AS2
<b>Ordering example</b>						
<b>187 432</b>	<b>DRQD</b>	<b>8</b>	<b>180</b>	<b>J60</b>	<b>A</b>	<b>A12</b>

**Ordering table**

Size	6	8	12	Conditions	Code	Enter code	
<b>M</b> Module No.	<b>187 431</b>		<b>187 432</b>	<b>187 433</b>			
Function	Semi-rotary drive with twin pistons				<b>DRQD</b>	DRQD	
Piston Ø [mm]	6	8	12		-...		
Swivel angle	90°				<b>-90</b>		
	180°				<b>-180</b>		
End-position adjustment	Adjusting range +6°/-20°				<b>-J20</b>		
	Adjusting range +6°/-60°				<b>-J60</b>		
Position sensing	For proximity sensing				<b>-A</b>	-A	
Output shaft/adaptor	Spigot shaft			<b>1</b>	<b>-ZW</b>		
	Flanged shaft			<b>2</b>	<b>-FW</b>		
	Adapter for HGWM-08		Adapter for HGPM-08/HGWM-08		<b>3</b>	<b>-A08</b>	
	Adapter for HGWM-12		Adapter for HGPM-12/HGWM-12		<b>3</b>	<b>-A12</b>	
	-		Adapter for DHWS/DHRS-10-A, DHPS-6-A		<b>4</b>	<b>-AS1</b>	
	-		Adapter for DHDS-16-A		<b>4</b>	<b>-AS2</b>	

- 1 ZW** Not with energy through-feed SD32  
Only with screw type ZS, HS
- 2 FW** Required for energy through-feed SD32  
Only with screw type ZS, HS

- 3 A08, A12** Not with energy through-feed SD32  
Only with screw type HS
- 4 AS1, AS2** Required for energy through-feed SD32  
Not with screw type ZS, HS

Transfer order code

**DRQD** -  -  -  - **A** -

# Semi-rotary drives DRQD-6 ... 12, twin-pistons

Ordering data – Modular products

→ **0 Options**

<b>Energy through-feed</b>	<b>Type of screw</b>	<b>Type of mounting</b>	<b>User's manual</b>
SD32	ZS HS	B1 B2 B3	E F S I V B
- SD32	- HS	- B2	- B

Ordering table						
Size	6	8	12	Conditions	Code	Enter code
<b>0</b> Energy through-feed	2x tubing O.D. 3 mm			<b>5</b>	<b>-SD32</b>	
Type of screw	Socket head screw				<b>-ZS</b>	
	Hollow bolt				<b>-HS</b>	
Type of mounting	Mounting type 1			<b>6</b>	<b>-B1</b>	
	Mounting type 2			<b>6</b>	<b>-B2</b>	
	Mounting type 3			<b>6</b>	<b>-B3</b>	
Alternative language user documentation (standard is German)	English				<b>-E</b>	
	French				<b>-F</b>	
	Spanish				<b>-S</b>	
	Italian				<b>-I</b>	
	Swedish				<b>-V</b>	
	Express waiver – no user manual to be included (already available)				<b>-B</b>	

**5 SD32** Only with mounting type B1, B2, B3

**6 B1, B2, B3** Only with energy through-feed SD32

Transfer order code

-  -  -  -

# Semi-rotary drives DRQD-B-16 ... 32, DRQD-40 ... 50, twin-pistons

Peripherals overview

Piston  $\varnothing$  16 ... 50

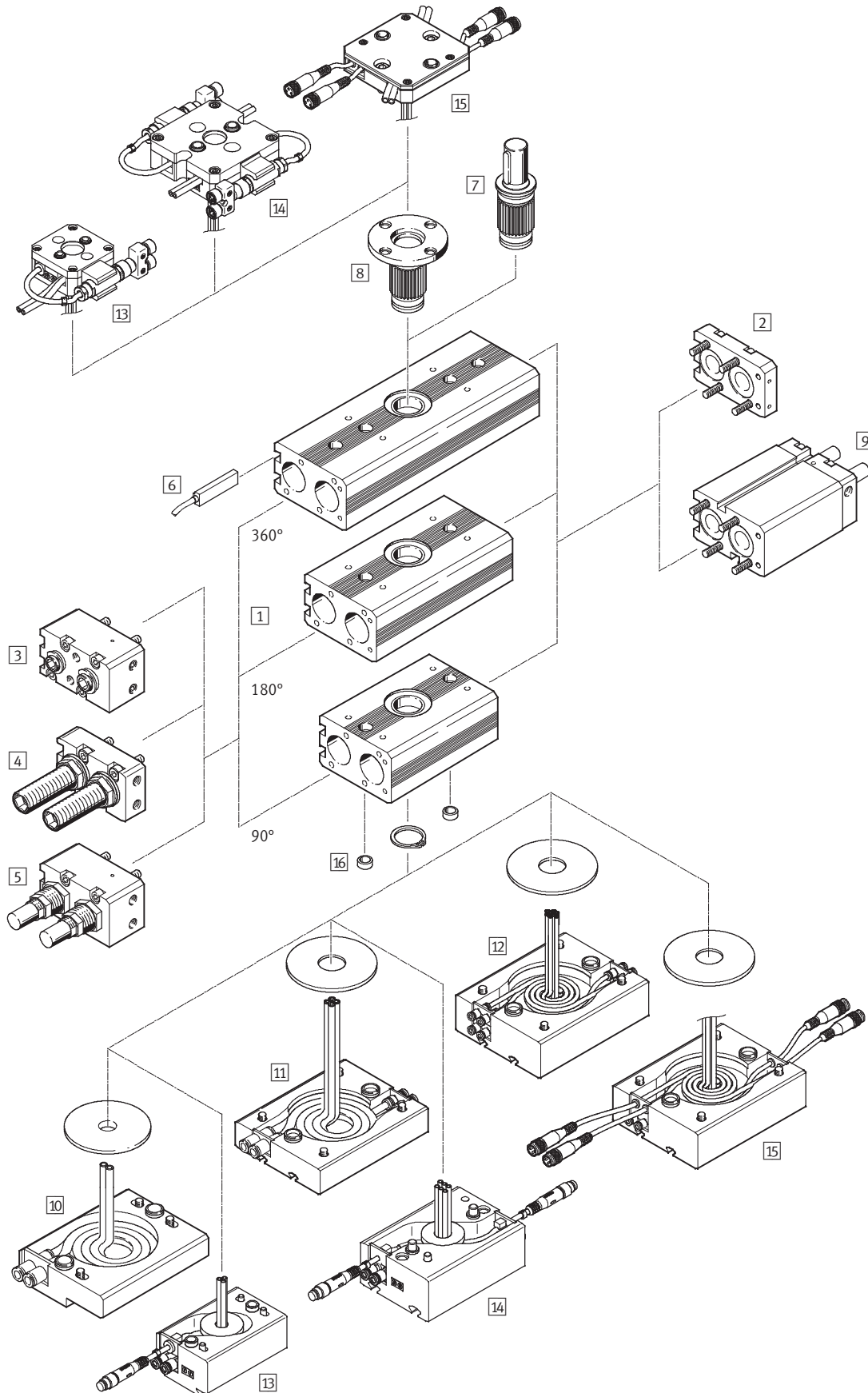

# Semi-rotary drives DRQD-B-16 ... 32, DRQD-40 ... 50, twin-pistons

Peripherals overview

Variants, mounting attachments and accessories								→ Page/Internet	
	Brief description	Piston ∅							
		16	20	25	32	40	50		
1	Centre section	Centre section for 90°, 180° or 360° swivel angle	■	■	■	■	■	■	60
2	End cap AL, AR	With integrated compressed air directional function	■	■	■	■	■	■	
3	Connector cap PPVJ	Flexible end position cushioning with adjustable end positions (–20° ... +6°)	■	■	■	■	■	■	
4	Connector cap P1J	Adjustable cushioning elements with adjustable end positions	■	■	■	■	–	–	
5	Connector cap YSRJ	Adjustable shock absorbers with adjustable end positions (–20° ... +6°)	■	■	■	■	■	■	
6	Position sensing A	Contactless via proximity sensors SME-/SMT-8	■	■	■	■	■	■	65
7	Spigot shaft ZW	With woodruff key	■	■	■	■	■	■	60
8	Flanged shaft FW	Hollow, for energy through-feed	■	■	■	■	■	■	
9	Intermediate position Z1	Mid-position at centre of nominal angles of rotation of 90° and 180° (±10°)	■	■	■	■	■	■	35
10	Energy through-feed SD32, SD42	2 tubes with O.D. 3 or 4 mm	■	■	■	■	–	–	36
	Energy through-feed SD62	2 tubes with O.D. 6 mm	–	–	–	–	■	■	
11	Energy through-feed SD64	4 tubes with O.D. 6 mm	–	–	–	–	■	■	
12	Energy through-feed SD48	8 tubes with O.D. 4 mm	–	–	–	–	■	■	
13	Energy through-feed E422	2 tubes with O.D. 4 mm and 1 4-pin cable to 2 3-pin cables	■	■	–	–	–	–	
14	Energy through-feed E444	4 tubes with O.D. 4 mm and 2 4-pin cables to 4 3-pin cables	–	–	■	■	–	–	
15	Energy through-feed E644	4 tubes with O.D. 6 mm and 4 3-pin cables	–	–	–	–	■	■	
16	Centring sleeve ZBH	For centring (2 pieces included in scope of delivery for DRQD)	■	■	■	■	■	■	64

# Semi-rotary drives DRQD-B-16 ... 32, DRQD-40 ... 50, twin-pistons

Type codes

DRQD - B - 32 - 90 - YSRJ - A - AR - FW

<b>Type</b>		DRQD	B	32	90	YSRJ	A	AR	FW
Double-acting									
DRQD	Semi-rotary drive								
<b>Product design</b>									
B	Function-optimized								
<b>Piston Ø [mm]</b>									
<b>Swivel angle [°]</b>									
<b>Type of cushioning</b>									
PPVJ	Adjustable end-position cushioning								
P1J	Adjustable flexible cushioning elements								
YSRJ	Adjustable shock absorbers								
<b>Position sensing</b>									
A	For proximity sensing								
<b>Pneumatic connection</b>									
AL	Supply port, left								
AR	Supply port, right								
<b>Output shaft</b>									
ZW	Spigot shaft								
FW	Flanged shaft								



# Semi-rotary drives DRQD-B-16 ... 32, DRQD-40 ... 50, twin-pistons

Type codes

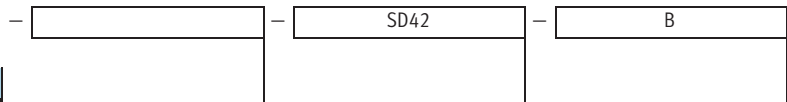

Intermediate position	
Z1	1 intermediate position (mid-position)

Energy through-feed	
SD32	2 tubes with O.D. 3 mm
SD42	2 tubes with O.D. 4 mm
SD48	8 tubes with O.D. 4 mm
SD62	2 tubes with O.D. 6 mm
SD64	4 tubes with O.D. 6 mm
E422	2 tubes with O.D. 4 mm and 1 4-pin cable to 2 3-pin cables
E444	4 tubes with O.D. 4 mm and 2 4-pin cables to 4 3-pin cables
E644	4 tubes with O.D. 6 mm and 4 3-pin cables

User's manual	
	German (standard)
E	English
F	French
S	Spanish
I	Italian
V	Swedish
B	Express waiver – no user manual to be included (already available)

# Semi-rotary drives DRQD-B-16 ... 32, DRQD-40 ... 50, twin-pistons

Technical data

Function



- Diameter  
16 ... 50 mm
- Force  
1.6 ... 50 Nm

Variants

- 90°, 180° and 360° or X swivel angle
- Spigot or flanged shaft
- Adjustable end-position cushioning or shock absorbers
- Position sensing
- Intermediate position
- Energy through-feed
- Different types of mounting

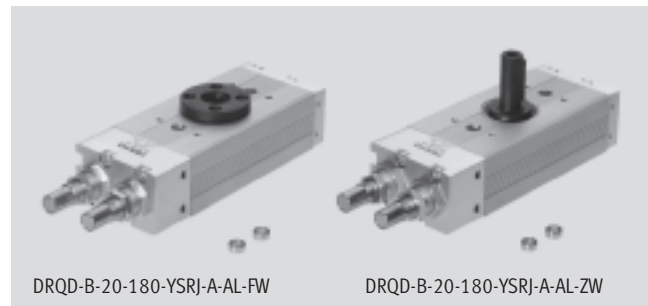

www.festo.com/en/  
Spare\_parts\_service

General technical data								
Piston Ø		16	20	25	32	40	50	
Pneumatic connection		M5			G1/8		G1/4	
	SD32	QS...-3 for tubing O.D. Ø 3 mm <sup>1)</sup>				-	-	
	SD42/SD48	QS...-4 for tubing O.D. Ø 4 mm <sup>1)</sup>				-	-	
	E422	QS...-4 for tubing O.D. 4 mm			-			
	E444	-			QS...-4 for tubing O.D. 4 mm		-	
SD62/SD64/ E644	-			QS...-6 for tubing O.D. 6 mm				
Constructional design		Semi-rotary drive with twin pistons based on the rack and pinion principle						
Cushioning	PPVJ	Adjustable, pneumatic						
	P1J	Adjustable, flexible cushioning elements				-		
	YSRJ	Adjustable, hydraulic shock absorbers						
Position sensing		For proximity sensing						
Type of mounting		Via through-hole						
		Via female thread						
Assembly position		Any						
Adjustable end-position range per end position	PPVJ	-20 ... +6						
	P1J	-270 ... +6	-320 ... +6	-280 ... +6	-210 ... +6	-		
	YSRJ	-20 ... +6						
Max. permissible swivelling frequency at 6 bar (for completed cycle of motion)	PPVJ	90°	4	3	2	1.2	1.2	1.2
		180°	3	2.2	1.3	0.8	0.9	0.9
		360°	1.5	1.2	0.8	0.5	0.5	0.5
	P1J	90°	3.6	3	2.5	2.2	-	-
		180°	2.5	2.2	1.9	1.6	-	-
		360°	1.5	1.2	1	0.8	-	-
	YSRJ	90°	2	2	1.5	1.2	1	0.9
		180°	1.8	1.8	1.5	1.2	1	0.8
		360°	1	1	0.9	0.8	0.7	0.6
	SD.../E...		A reduction of max. 5% of the values indicated above					
			- <sup>1)</sup> Note: At temperatures < 0 °C, a max. frequency of 1 Hz applies in the case of variant YSRJ					

# Semi-rotary drives DRQD-B-16 ... 32, DRQD-40 ... 50, twin-pistons

Technical data

General technical data										
Piston Ø				16	20	25	32	40	50	
Minimum cycle times in conjunction with Z1 (from the end position to the intermediate position)	[s]	PPVJ	90°	0.20	0.22	0.18	0.21	0.20	0.18	
			180°	0.26	0.41	0.20	0.26	0.21	0.35	
	YSRJ	90°	0.20	0.22	0.17	0.20	0.47	0.35		
		180°	0.23	0.31	0.22	0.23	1.10	0.99		
Repetition accuracy (approached from both ends)	[°]	Z1	≤ 0.05				≤ 0.25		≤ 0.20	≤ 0.30
			≤ 0.15							

Operating and environmental conditions									
Piston Ø				16	20	25	32	40	50
Operating medium				Compressed air in accordance with ISO 8573-1:2010 [7:4:4]					
Note on operating/pilot medium				Operation with lubricated medium possible (in which case lubricated operation will always be required)					
Operating pressure	[bar]	PPVJ	1 ... 10						
Operating pressure	[bar]	P1J	3 ... 10					-	
		YSRJ	2 ... 10						
		Z1	1 ... 10						
Ambient temperature	[°C]	-10 ... +60							
Corrosion resistance class CRC <sup>1)</sup>				1					
ATEX				Specified types → <a href="http://www.festo.com">www.festo.com</a>					

1) Corrosion resistance class 1 according to Festo standard 940 070  
Components requiring low corrosion resistance. Transport and storage protection. Parts that do not have primarily decorative surface requirements, e.g. in internal areas that are not visible or behind covers

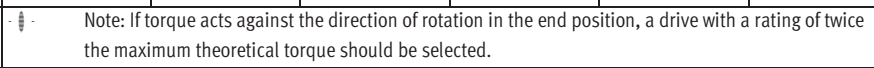
Forces and torques										
Piston Ø				16	20	25	32	40	50	
Theoretical torque at 6 bar	[Nm]			1.6	3.1	6.1	12.5	25	50	
		Z1		1.7	3.6	6.2	13.5	32.2	78.6	
										
Max. permissible radial and axial forces				Graphs → 33						
Max. permissible mass moment of inertia	[kgm <sup>2</sup> ]	PPVJ		5 x 10 <sup>-4</sup>	10 x 10 <sup>-4</sup>	20 x 10 <sup>-4</sup>	40 x 10 <sup>-4</sup>	200 x 10 <sup>-4</sup>	500 x 10 <sup>-4</sup>	
		P1J		Graphs → 30					-	
		YSRJ		Graphs → 31						
		PPVJ-Z1		5 x 10 <sup>-4</sup>	10 x 10 <sup>-4</sup>	20 x 10 <sup>-4</sup>	40 x 10 <sup>-4</sup>	200 x 10 <sup>-4</sup>	500 x 10 <sup>-4</sup>	
		YSRJ-Z1		-	-	-	-	1000 x 10 <sup>-4</sup>	2000 x 10 <sup>-4</sup>	
The data applies to the variants ZW, FW, without grippers and unthrottled.										

# Semi-rotary drives DRQD-B-16 ... 32, DRQD-40 ... 50, twin-pistons

Technical data

Weights [g]								
Piston Ø		16	20	25	32	40	50	
Connection cap AL/AR	PPVJ	116	220	358	609	1,170	2,320	
	P1J	140	240	335	610	–		
	YSRJ	140	240	441	917	2,170	4,270	
Centre section/output shaft	90°	ZW	379	609	1,026	1,891	3,330	6,860
		FW	380	586	1,018	1,848	3,960	7,010
	180°	ZW	467	753	1,267	2,325	4,340	8,850
		FW	468	730	1,259	2,282	4,570	9,000
	360°	ZW	643	1,039	1,741	3,199	6,350	12,890
		FW	644	1,016	1,733	3,165	6,580	13,040
End cap		40	53	82	140	370	610	
Intermediate position	90°	Z1	235	315	550	805	2,510	3,960
	180°	Z1	235	315	550	805	2,510	3,960
Flanged shaft with energy through-feed	SD32	152		303		–		
	SD42	152		303		–		
	SD48	–		–		1,220		
	SD62	–		–		900		
	SD64	–		–		930		
	E422	400		–		–		
	E444	–		800		–		
	E644	–		–		2,700		

## Direction of rotation of the drive shaft

Connection cap on right (AR)

Pneumatic actuation of ports 1 or 2 produces a rotational movement in direction R1 or R2 respectively.

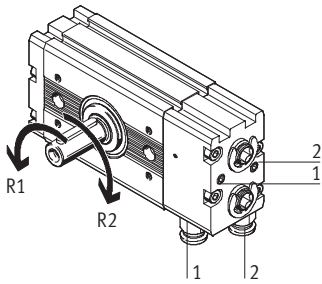

Connection cap on left (AL)

Pneumatic actuation of ports 1 or 2 produces a rotational movement in direction R1 or R2 respectively.

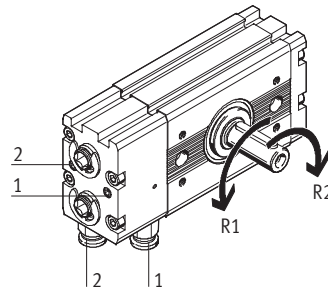

# Semi-rotary drives DRQD-B-16 ... 32, DRQD-40 ... 50, twin-pistons

Technical data

## Materials

Sectional view

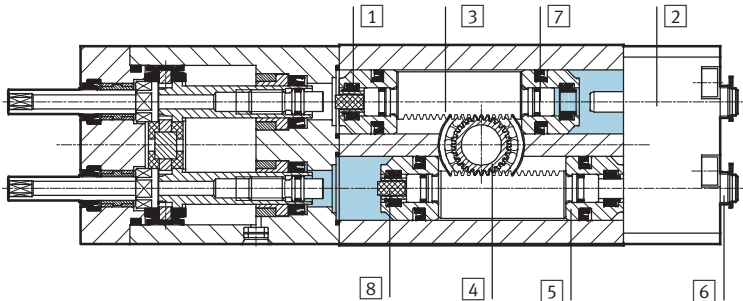

Piston Ø	16	20	25	32	40	50
<b>Basic drive</b>						
1	Cylinder barrel (centre section)	Anodised aluminium			Wrought aluminium alloy, anodised	
2	Connector cap	Anodised aluminium				
3	Gear rack	High-alloy stainless steel, hardened			High-alloy steel	
4	Pinion	Tempered steel				
5	Piston	Anodised aluminium				
6	Adjustable sleeve	Galvanised steel				
		P1J Stainless steel				
7	Piston seal	Polyurethane				
-	Material note	Copper, PTFE and silicone-free RoHS-compliant				
<b>Function end cap PPVJ</b>						
-	Cushioning seal	Nitrile rubber/polyurethane			Polyurethane	
-	Buffer sleeve, regulating screw	Anodised aluminium				
<b>Function end cap P1J</b>						
-	Cap, housing	Aluminium			-	
-	Seals	Nitrile rubber/thermoplastic polyurethane elastomer			-	
<b>Function end cap YSRJ</b>						
-	Buffer	Delrin				
-	Rod wiper seal	Nitrile rubber/polyurethane				
<b>Energy through-feed SD.../E...</b>						
-	Transfer plate/sliding disc	Anodised aluminium				
-	DUO spiral tubing	Polyurethane				
<b>Z1 intermediate position module</b>						
-	Piston	Stainless steel; nitrile rubber				
-	Piston rod, nut	Stainless steel				
-	Bearings	POM				
-	Rod wiper seal	Polyurethane				

# Semi-rotary drives DRQD-B-16 ... 32, DRQD-40 ... 50, twin-pistons

Technical data

## Maximum permitted mass moment of inertia J on the output shaft as a factor of swivel time t

DRQD-B-16-...-P1J

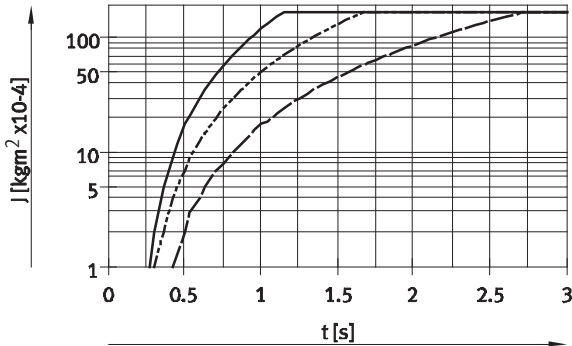

Max. permitted mass moment =  $175 \text{ kgm}^2 \times 10^{-4}$

DRQD-B-20-...-P1J

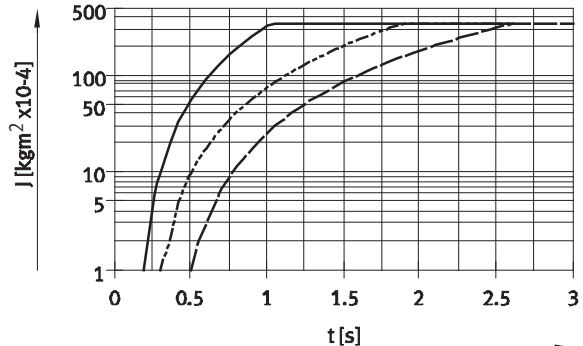

Max. permitted mass moment =  $350 \text{ kgm}^2 \times 10^{-4}$

DRQD-B-25-...-P1J

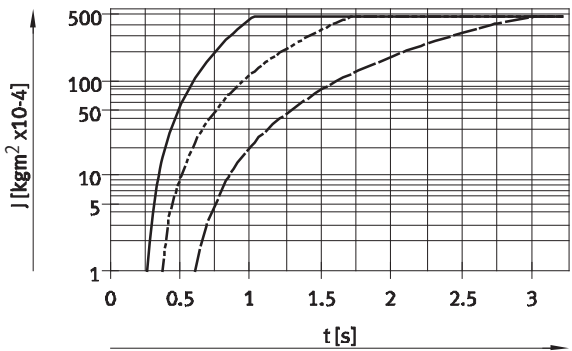

Max. permitted mass moment =  $500 \text{ kgm}^2 \times 10^{-4}$

DRQD-B-32-...-P1J

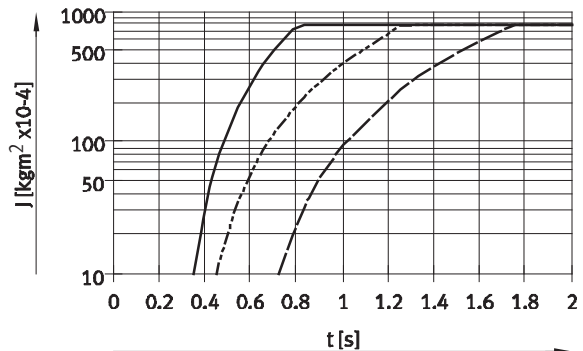

Max. permitted mass moment =  $800 \text{ kgm}^2 \times 10^{-4}$

- 90°
- - - 180°
- 360°

# Semi-rotary drives DRQD-B-16 ... 32, DRQD-40 ... 50, twin-pistons

Technical data

## Maximum permitted mass moment of inertia J on the output shaft as a factor of swivel time t

DRQD-B-16-...-YSRJ

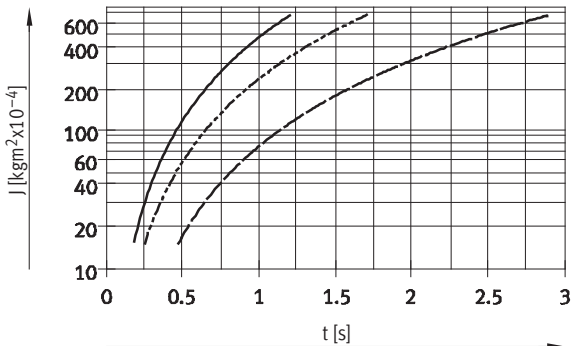

Max. permitted mass moment =  $700 \text{ kgm}^2 \times 10^{-4}$

DRQD-B-20-...-YSRJ

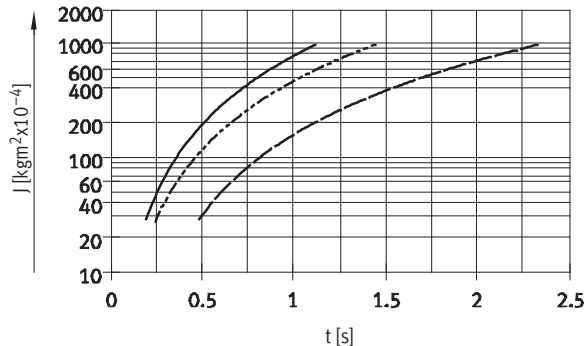

Max. permitted mass moment =  $1\,000 \text{ kgm}^2 \times 10^{-4}$

DRQD-B-25-...-YSRJ

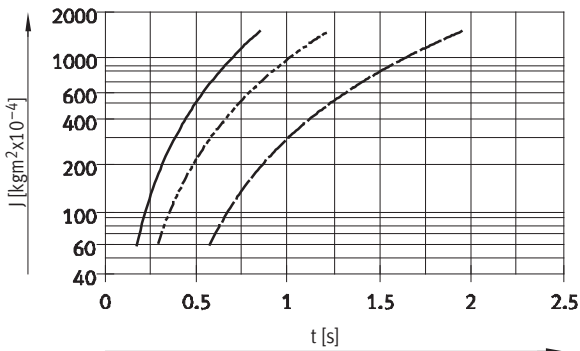

Max. permitted mass moment =  $1\,500 \text{ kgm}^2 \times 10^{-4}$

DRQD-B-32-...-YSRJ

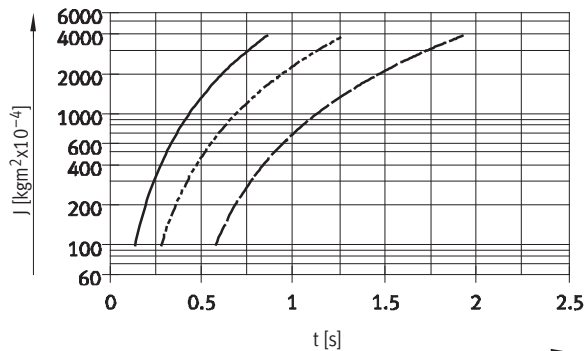

Max. permitted mass moment =  $4\,000 \text{ kgm}^2 \times 10^{-4}$

DRQD-40-...-YSRJ

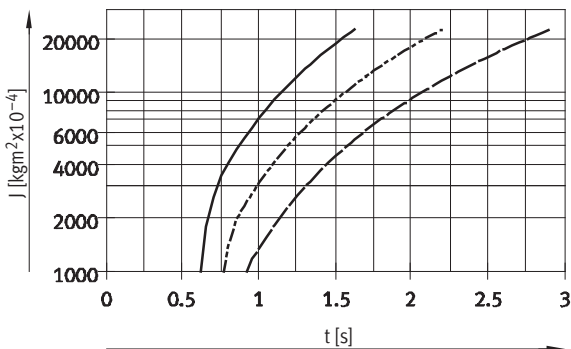

Max. permitted mass moment =  $23\,000 \text{ kgm}^2 \times 10^{-4}$

DRQD-50-...-YSRJ

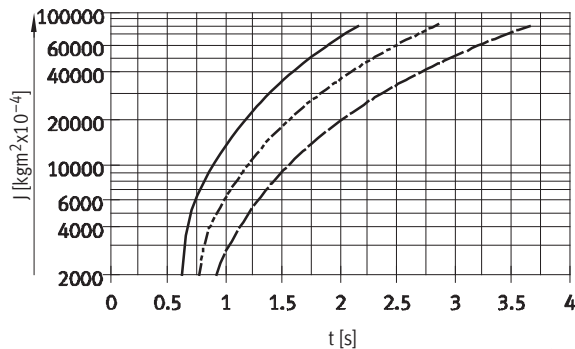

Max. permitted mass moment =  $83\,000 \text{ kgm}^2 \times 10^{-4}$

- 90°
- - - 180°
- · - · 360°

# Semi-rotary drives DRQD-B-16 ... 32, DRQD-40 ... 50, twin-pistons

Technical data

FESTO

## Max. permissible radial and axial forces on the drive shaft

### Combined load

A DRQD-B-16-...-FW is to be statically loaded with a radial force  $F_y = 300\text{ N}$ , which is at a distance of  $Z = 15\text{ mm}$  from the flanged shaft, and an axial

force  $F_{x, \text{push}} = 100\text{ N}$ , which is at a distance of  $V = 25\text{ mm}$  from the shaft (→ diagram of flanged shaft on right).

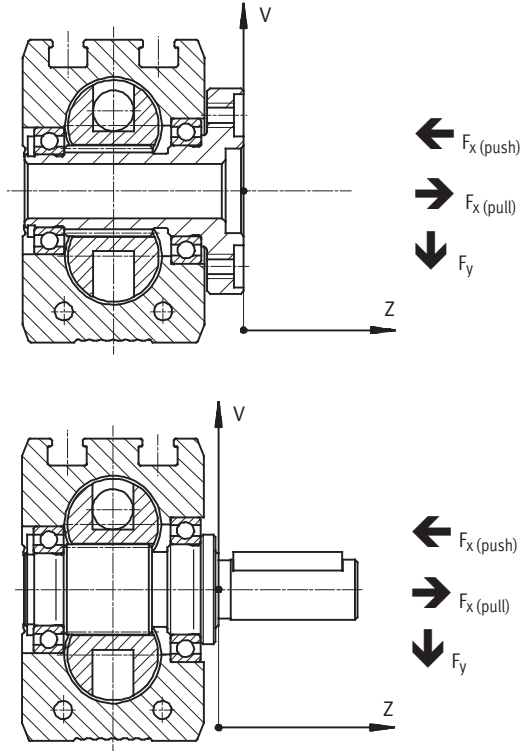

### Question:

Is it permissible to statically load a DRQD-B-16-...-FW with these combined forces?

### Answer:

According to graph 1 (→ 33), a distance of  $Z = 15\text{ mm}$  results in a maximum permissible radial force

$F_{y, \text{max. (stat.)}}(15) = 400\text{ N}$ .  
According to graph 3 (→ 33), a distance of  $V = 25\text{ mm}$  results in a

maximum permissible axial force  
 $F_{x, \text{push max. (stat.)}}(25) = 550\text{ N}$ .

The following equation applies to combined loads:

$$\frac{F_y(z)}{F_{y, \text{max. (z)}}} + \frac{F_{x, \text{push}}(v)}{F_{x, \text{push, max. (v)}}} + \frac{F_{x, \text{pull}}(v)}{F_{x, \text{pull, max. (v)}}} \leq 1$$

The following values are assumed:

$F_y(15) = 300\text{ N}$   
 $F_{x, \text{push (stat.)}}(25) = 100\text{ N}$   
 $F_{y, \text{max. (stat.)}}(15) = 400\text{ N}$   
 $F_{x, \text{max. (stat.)}}(25) = 550\text{ N}$

With values inserted:

$$\frac{300\text{ N}}{400\text{ N}} + \frac{100\text{ N}}{550\text{ N}} \leq 1$$

$$0.75 + 0.182 \leq 1$$

$$0.932 \leq 1$$

Thus the drive may be statically loaded with the forces indicated above.



# Semi-rotary drives DRQD-B-16 ... 32, DRQD-40 ... 50, twin-pistons

Technical data

## Maximum static radial force

Graph 1

$$F_{y, \text{max. (stat.)}} = f(z)$$

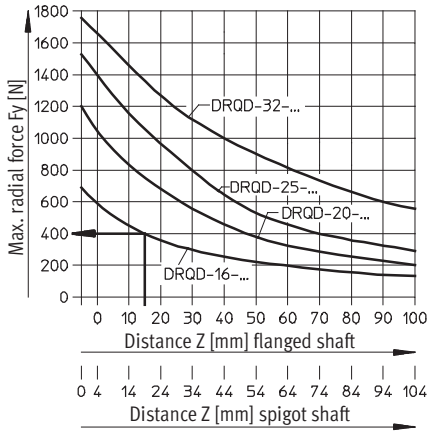

## Maximum dynamic radial force

Graph 2

$$F_{y, \text{max. (dyn.)}} = f(z)$$

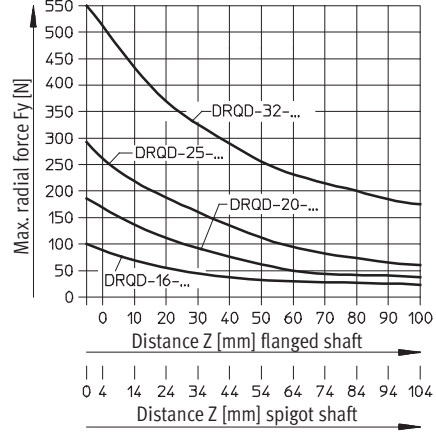

## Maximum static axial pushing force

Graph 3

$$F_{x, \text{push max. (stat.)}} = f(v)$$

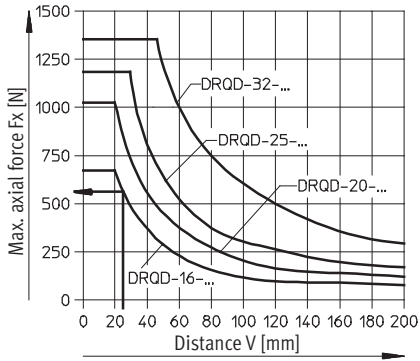

## Maximum dynamic axial pushing force

Graph 4

$$F_{x, \text{push max. (dyn.)}} = f(v)$$

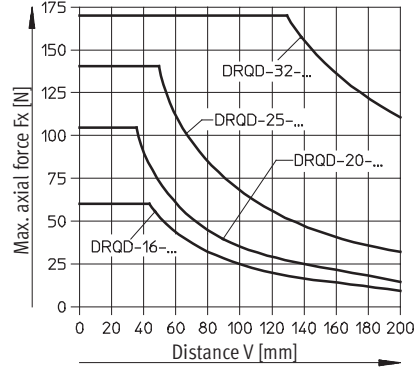

## Maximum static axial pulling force

Graph 5

$$F_{x, \text{pull max. (stat.)}} = f(v)$$

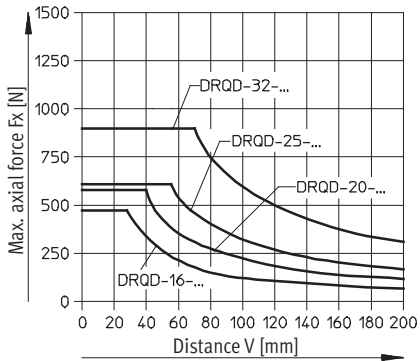

## Maximum dynamic axial pulling force

Graph 6

$$F_{x, \text{pull max. (dyn.)}} = f(v)$$

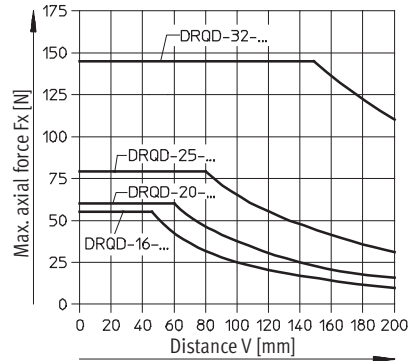

# Semi-rotary drives DRQD-B-16 ... 32, DRQD-40 ... 50, twin-pistons

Technical data

## Maximum static radial force

Graph 1

$$F_{y, \text{max. (stat.)}} = f(z)$$

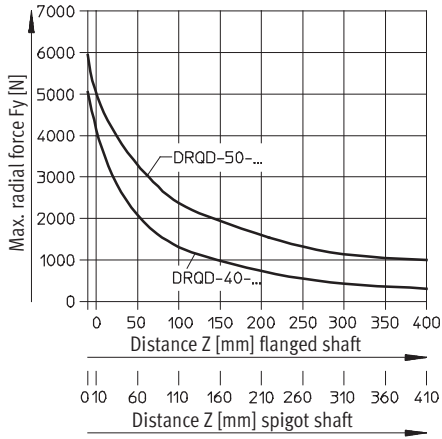

## Maximum dynamic radial force

Graph 2

$$F_{y, \text{max. (dyn.)}} = f(z)$$

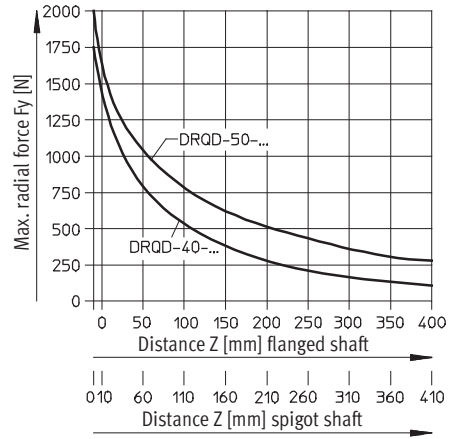

## Maximum static axial pushing force

Graph 3

$$F_{x, \text{push max. (stat.)}} = f(v)$$

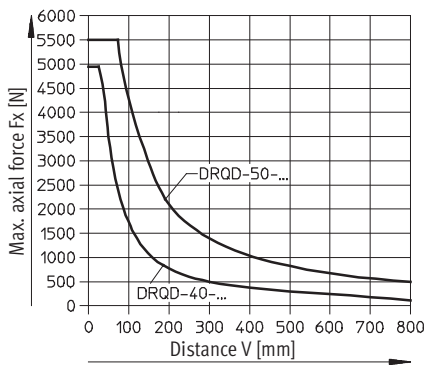

## Maximum dynamic axial pushing force

Graph 4

$$F_{x, \text{push max. (dyn.)}} = f(v)$$

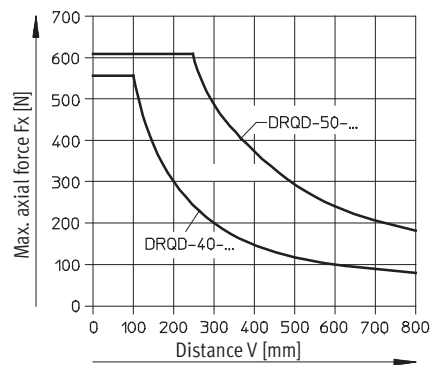

## Maximum static axial pulling force

Graph 5

$$F_{x, \text{pull max. (stat.)}} = f(v)$$

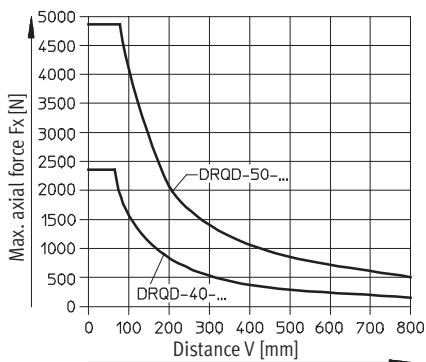

## Maximum dynamic axial pulling force

Graph 6

$$F_{x, \text{pull max. (dyn.)}} = f(v)$$

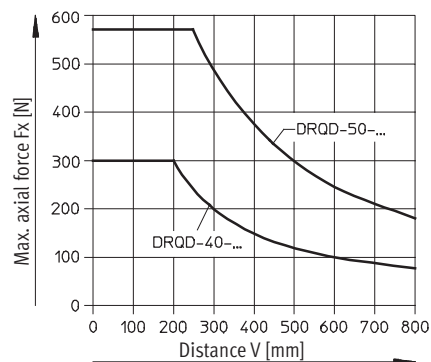

# Semi-rotary drives DRQD-B-16 ... 32, DRQD-40 ... 50, twin-pistons

Technical data

## Z1 intermediate position module

For  $\varnothing 16 \dots 50$

The intermediate position module is fitted in place of the end cap, and allows for adjustable, backlash-free positioning of the drive at 50% of its nominal rotation angle. The intermediate position module is available for nominal rotation angles of 90° and 180°.

The intermediate position module cannot be used in combination with cushioning type DRQD-...-P1J.

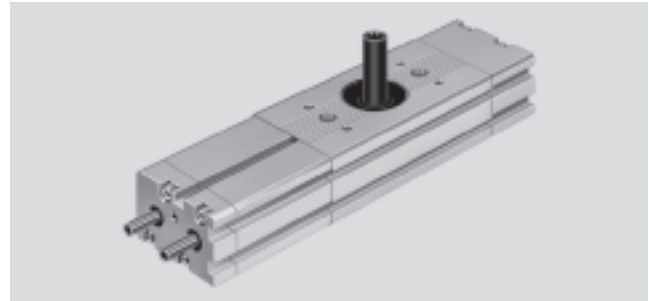

## Function

A piston incorporating two screw fastened piston rods is pressurised and shifts the semi-rotary drive gear racks until both make full contact with

the piston rods in the mid-position module. The mid-position can be accurately adjusted within a range of  $\pm 10^\circ$  with the adjusting screws in the

piston rods. Thanks to the hollow shaft design of the piston rod, adjustment can be performed under pressure.

The through rods in the mid-position module are guided by means of multiple bearings in the cover and in the adapter.

## Actuation

In order for the mid-position module to function, the DRQD basic actuator must be pressurised at both sides.

This can be accomplished with two different types of actuation:

### Actuation type 1

- Mid-position module (supply air must be restricted) with a 3/2-way valve

- DRQD basic drive with a 5/3-way valve, mid-position pressurised

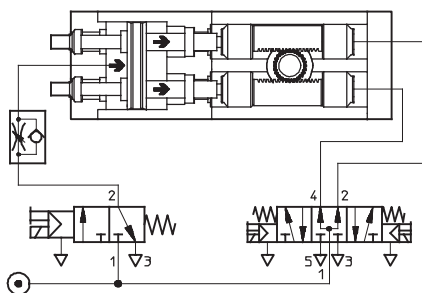

### Actuation type 2

- Mid-position module (supply air must be restricted) with a 3/2-way valve

- DRQD basic drive with two 3/2-way valves, spring return

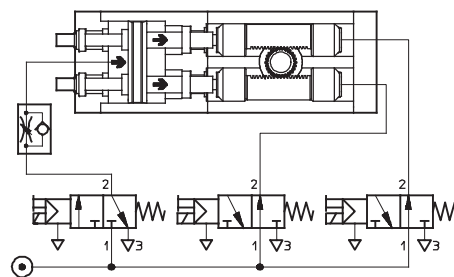

## Note

Even if the semi-rotary drives DRQD-B-16 to 32 have been equipped with shock absorbers (type YSRJ), the mid-position may not be loaded with

more than the max. permissible mass moment of inertia for the PPVJ variant! The reason for this is the cushioning: Whereas loads can be absorbed in the

end positions with the shock absorbers, the mid-position is only equipped with basic flexible cushioning. Additional information on

the permissible mass moment of inertia for the sizes 40 and 50 mm: **→ 27**

# Semi-rotary drives DRQD-B-16 ... 32, DRQD-40 ... 50, twin-pistons

Technical data

Energy through-feed	
DRQD-...-SD...	DRQD-...-E...
The energy through-feed consists of one to max. four DUO tubes (fused tubing pair), whereby each tube has an O.D. of 3 ... 6 mm. Compressed air is supplied via the push-in fittings in	the transfer plate. Only Quick-Star push-in fittings may be used to connect compressed air tubing to consuming devices (e.g. grippers).
	The energy through-feed consists of one to max. two DUO tubes (fused tubing pair), whereby each tube has an O.D. of 4 ... 6 mm. Compressed air is supplied via the push-in fittings in the transfer plate. Only Quick-Star
	push-in fittings may be used to connect compressed air tubing to consuming devices (e.g. grippers). In addition, up to four proximity sensors can be connected by means of this energy through-feed.

DRQD-...-SD...



- For piston  $\varnothing$  16 ... 50
- Swivel angles of up to 360° are possible
- 1 ... 4 DUO tubes

Technical data		16	20	25	32	40	50	
Piston $\varnothing$								
Number of DUO tubes	SD32	1				–		
	SD42	1				–		
	SD48	–				4		
	SD62	–				1		
	SD64	–				2		
Standard nominal flow rate (per tube) [l/min]	SD32	min. 70				–		
	SD42	min. 130				–		
	SD48	–				min. 130		
	SD62	–				min. 250		
	SD64	–				min. 250		
Theoretical air consumption per line at 6 bar [cm <sup>3</sup> ]	SD32	5.3				–		
	SD42	9.5				–		
	SD48	–				9.5		
	SD62	–				24.4		
	SD64	–				24.4		
Operating pressure as a function of ambient temperature [bar]		0 ... 10 (at –10 ... +30 °C)						
		0 ... 9 (at –30 ... +40 °C)						
		0 ... 7 (at –40 ... +60 °)						
Tube O.D. on flanged shaft drive side [mm]	SD32	3				–		
	SD42	4				–		
	SD48	–				4		
	SD62	–				6		
	SD64	–				6		
Push-in fittings for connection to consuming device [mm]	SD32	QS-...-3 for tube O.D. 3 mm					–	
	SD42	QS-...-4 for tube O.D. 4 mm					–	
	SD48	–				QS-...-4 for tube O.D. 4 mm		
	SD62	–				QS-...-6 for tube O.D. 6 mm		
	SD64	–				QS-...-6 for tube O.D. 6 mm		

# Semi-rotary drives DRQD-B-16 ... 32, DRQD-40 ... 50, twin-pistons

Technical data

## Energy through-feed

DRQD-...-E422

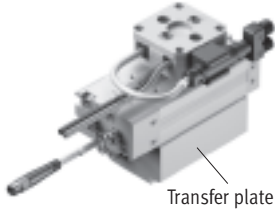

Transfer plate

- For piston  $\varnothing$  16/20
- Swivel angles of up to 180° are possible
- 1 DUO tube with O.D. 4 mm
- 1 4-pin cable to 2 3-pin cables

DRQD-...-E444

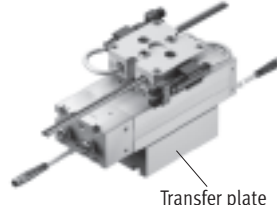

Transfer plate

- For piston  $\varnothing$  25/32
- Swivel angles of up to 180° are possible
- 2 DUO tubes each with O.D. 4 mm
- 2 4-pin cables to 4 3-pin cables

DRQD-...-E644

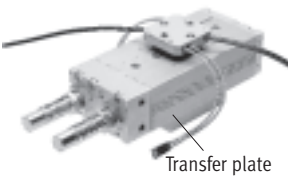

Transfer plate

- For piston  $\varnothing$  40/50
- Swivel angles of up to 180° are possible
- 2 DUO tubes each with O.D. 6 mm
- 4 3-pin cables

## Technical data

Piston $\varnothing$		16	20	25	32	40	50
Number of DUO tubes	E422	1		-			
	E444	-		2		-	
	E644	-		-		2	
Standard nominal flow rate (per tube) [l/min]	E422	min. 130		-			
	E444	-		min. 130		-	
	E644	-		-		min. 250	
Theoretical air consumption per line at 6 bar [cm <sup>3</sup> ]	E422	9.5		-			
	E444	-		9.5		-	
	E644	-		-		24.4	
Operating pressure as a function of ambient temperature [bar]		0 ... 10 (at -10 ... +30 °C)					
		0 ... 9 (at +30 ... +40 °C)					
		0 ... 7 (at +40 ... +60 °C)					
Tube O.D. on flanged shaft drive side [mm]	E422	4		-			
	E444	-		4		-	
	E644	-		-		6	
Push-in fittings for connection to consuming device [mm]	E422	QS-...-4 for tube O.D. 4 mm		-			
	E444	-		QS-...-4 for tube O.D. 4 mm		-	
	E644	-		-		QS-...-6 for tube O.D. 6 mm	

# Semi-rotary drives DRQD-B-16 ... 32, twin-pistons

Technical data

**Dimensions**

Download CAD Data → [www.festo.com/us/cad](http://www.festo.com/us/cad)

ZW – Spigot shaft

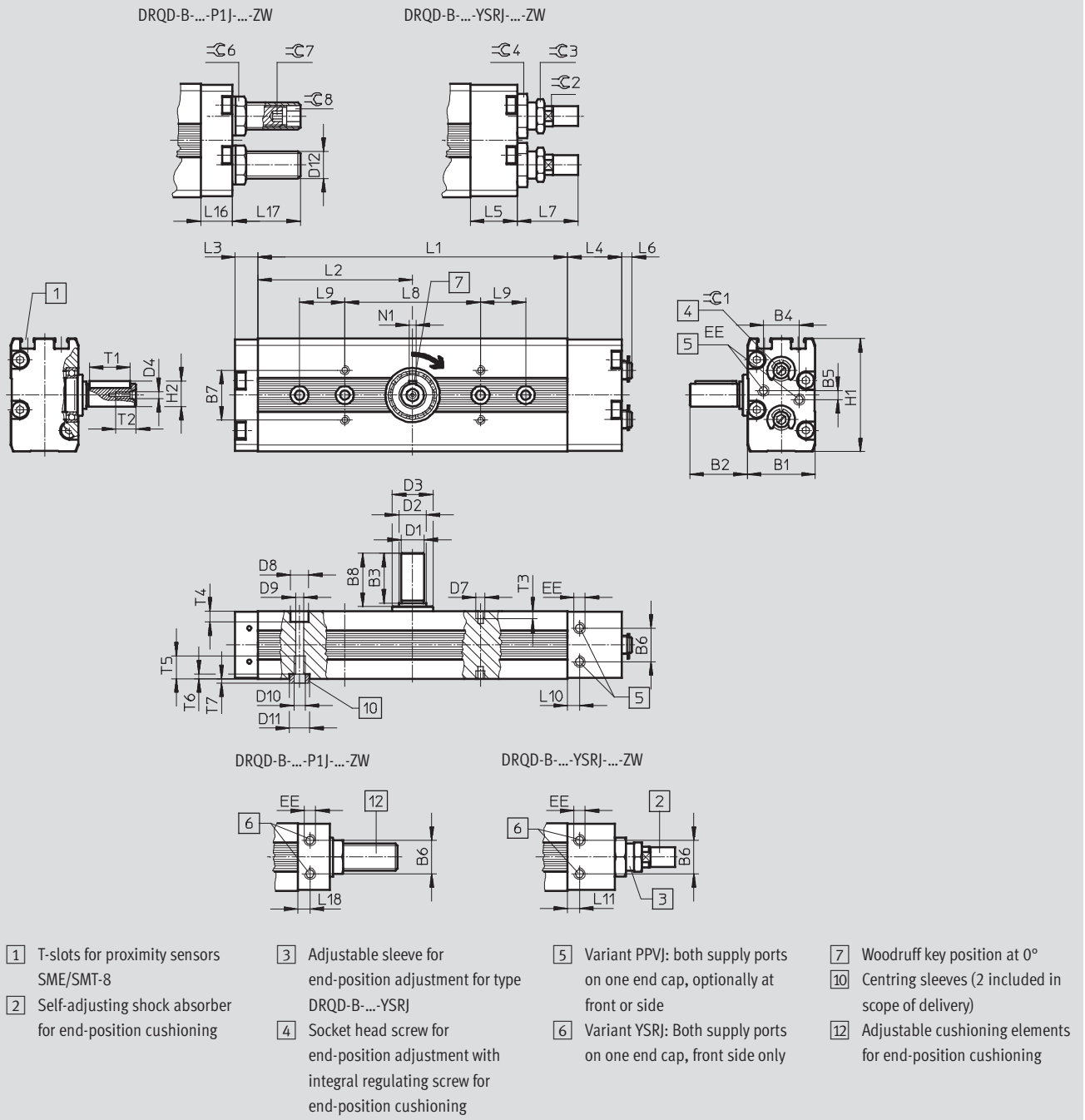

# Semi-rotary drives DRQD-B-16 ... 32, twin-pistons

Technical data

∅ [mm]	Swivel angle [°]	B1	B2	B3	B4	B5	B6	B7	B8	D1 ∅ g6	D2 ∅	D3 ∅	D4	D7	D8 ∅ H13	D9 ∅	D10	D11 ∅ H7	D12
16	90	30	25.5	23	17.8	4	14.8	22	23.5	10	12	18	M3	M4	8	4.2	M5	9	M12
	180																		
	360																		
20	90	36	32.5	30	21.8	4	19.8	26	30.5	12	15	24	M4	M4	8	4.2	M5	9	M14
	180																		
	360																		
25	90	42	42.5	40	24.8	4	24.8	30	40.5	16	20	30	M5	M5	10	5.3	M6	9	M16
	180																		
	360																		
32	90	51	52.5	50	29.8	2	29.8	36	50.5	20	25	35	M6	M5	10	5.3	M6	9	M22
	180																		
	360																		

∅ [mm]	Swivel angle [°]	EE	H1	H2	L1	L2	L3	L4	L5	L6		L7		L8 ±0.03	L9 ±0.03	L10	L11	L16
										min.	max.	min.	max.					
16	90	M5	50	11.2	71	35.5	10	24	20.8	1.7	5.7	23.4	28.2	60	-	7.6	5.3	14
	180				93	46.5									-			
	360				137	68.5									20			
20	90	M5	56	13.5	78.4	39.2	10	31.5	27	2.4	7	28.6	35.9	60	-	8	5	13.5
	180				104.8	52.4									-			
	360				157.6	78.8									20			
25	90	M5	67	18	91.2	45.6	11	36.5	33	2.6	8.9	42	50.2	60	-	11	5	15
	180				124	62									-			
	360				189.2	94.6									20			
32	90	G½	79	22.5	114.8	57.4	13	39	39	4.3	11.8	59.4	70.1	80	-	13.1	8	20
	180				155.6	77.8									20			
	360				237.4	118.7									20			

∅ [mm]	Swivel angle [°]	L17		L18	N1 P9	T1	T2	T3	T4	T5	T6	T7	≅C1	≅C2	≅C3	≅C4	≅C6	≅C7	≅C8
		min.	max.																
16	90	6.7	41	5.8	3	18.1	9	3.5	5	10	2	2	4	9	13	17	15	4	8
	180																		
	360																		
20	90	8.5	59.5	5	4	25.1	10	3.5	5	12	2	2	7	11	15	19	17	4	8
	180																		
	360																		
25	90	9	61.4	5	5	36.1	12.5	5	6	12	2	2	7	15	19	24	19	5	10
	180																		
	360																		
32	90	10	60	8	6	45.1	16	5	6	14	2	2	8	20	27	32	27	5	10
	180																		
	360																		

# Semi-rotary drives DRQD-40 ... 50, twin-pistons

Technical data

FESTO

## Dimensions

Download CAD Data → [www.festo.com/us/cad](http://www.festo.com/us/cad)

ZW – Spigot shaft

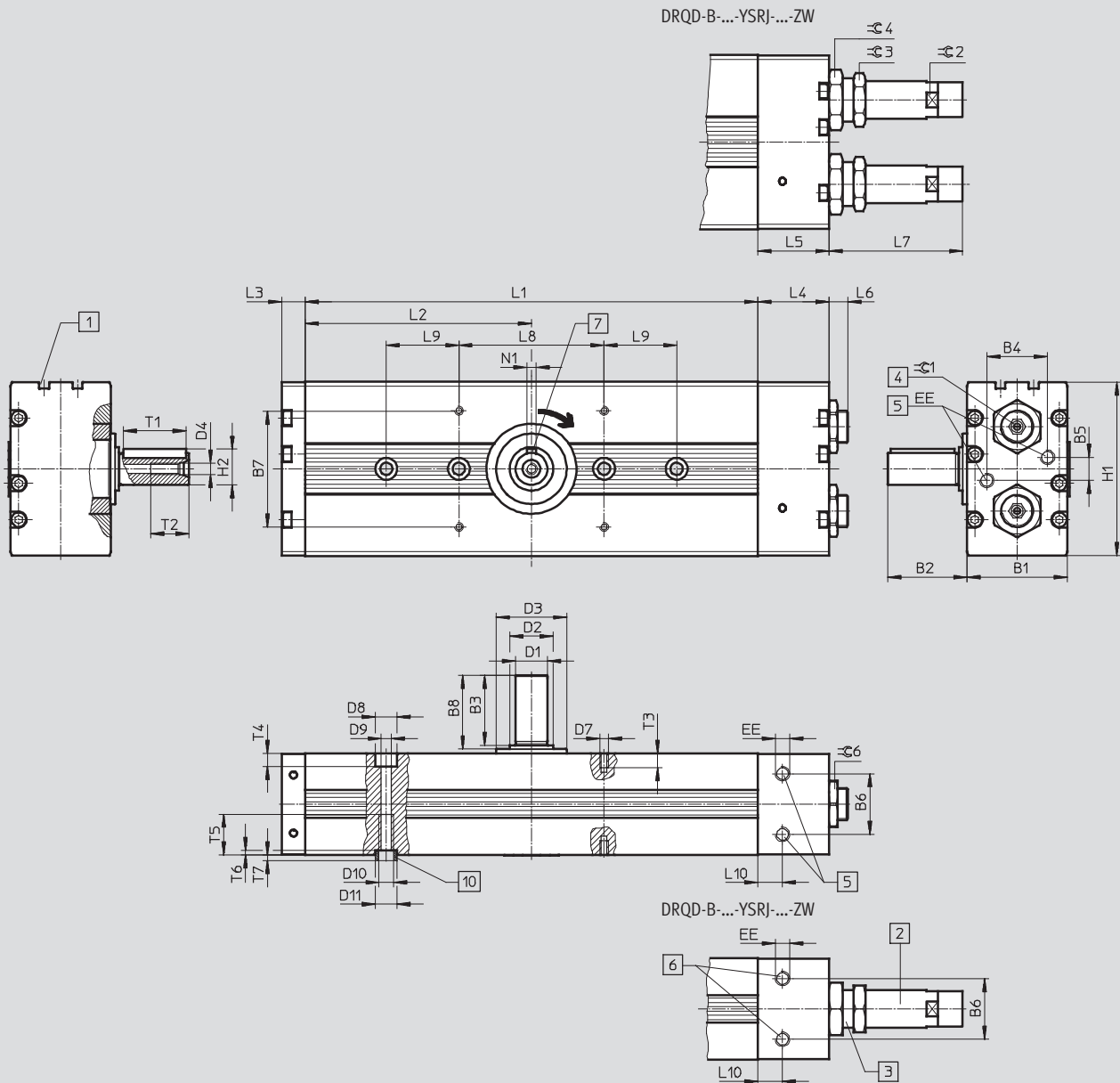

- |   |   |   |   |
|---|---|---|---|
| <p>1 T-slots for proximity sensors SME/SMT-8</p> <p>2 Self-adjusting shock absorber for end-position cushioning</p> | <p>3 Adjustable sleeve for end-position adjustment for type DRQD-...-YSRJ</p> <p>4 Socket head screw for end-position adjustment with integral regulating screw for end-position cushioning</p> | <p>5 Variant PPVJ: both supply ports on one end cap, optionally at front or side</p> <p>6 Variant YSRJ: both supply ports on one end cap, front side only</p> | <p>7 Woodruff key position at 0°</p> <p>10 Centring sleeves (2 included in scope of delivery)</p> |
|---|---|---|---|



# Semi-rotary drives DRQD-40 ... 50, twin-pistons

Technical data

∅ [mm]	Swivel angle [°]	B1	B2	B3	B4	B5	B6	B7	B8	D1 ∅ g6	D2 ∅	D3 ∅	D4	D7	D8 ∅ H13	D9 ∅
40	90	70	53.5	50	42	4	42	80	50.5	22	30	48.5	M8	M6	15	8.5
	180															
	360															
50	90	86	63.5	60	50	16	50	80	60.9	28	38	58.5	M12	M6	15	8.5
	180															
	360															

∅ [mm]	Swivel angle [°]	D10	D11 ∅ H7	EE	H1	H2	L1	L2	L3	L4	L5	L6		L7		L8 ±0.03
												min.	max.	min.	max.	
40	90	M10	15	G1/8	120	24.5	146.8	73.4	16	49	41.5	5	14.6	85.1	96.4	100
	180						201.8	100.9								
	360						311.8	155.9								
50	90	M10	15	G1/4	144	31	191.4	95.7	18	64	55	8	20.7	107.8	120.6	100
	180						262.8	131.4								
	360						405.8	202.9								

∅ [mm]	Swivel angle [°]	L9 ±0.03	L10	N1 P9	T1	T2 +2	T3	T4	T5	T6	T7	≈C1	≈C2	≈C3	≈C4	≈C6
180	-															
360	50															
50	90	-	21.2	8	56.1	28	10	11	28	3	3	14	28	36	46	41
	180	50														
	360	100														

# Semi-rotary drives DRQD-B-16 ... 32, twin-pistons

Technical data

FESTO

## Dimensions

Download CAD Data → [www.festo.com/us/cad](http://www.festo.com/us/cad)

FW – Flanged shaft

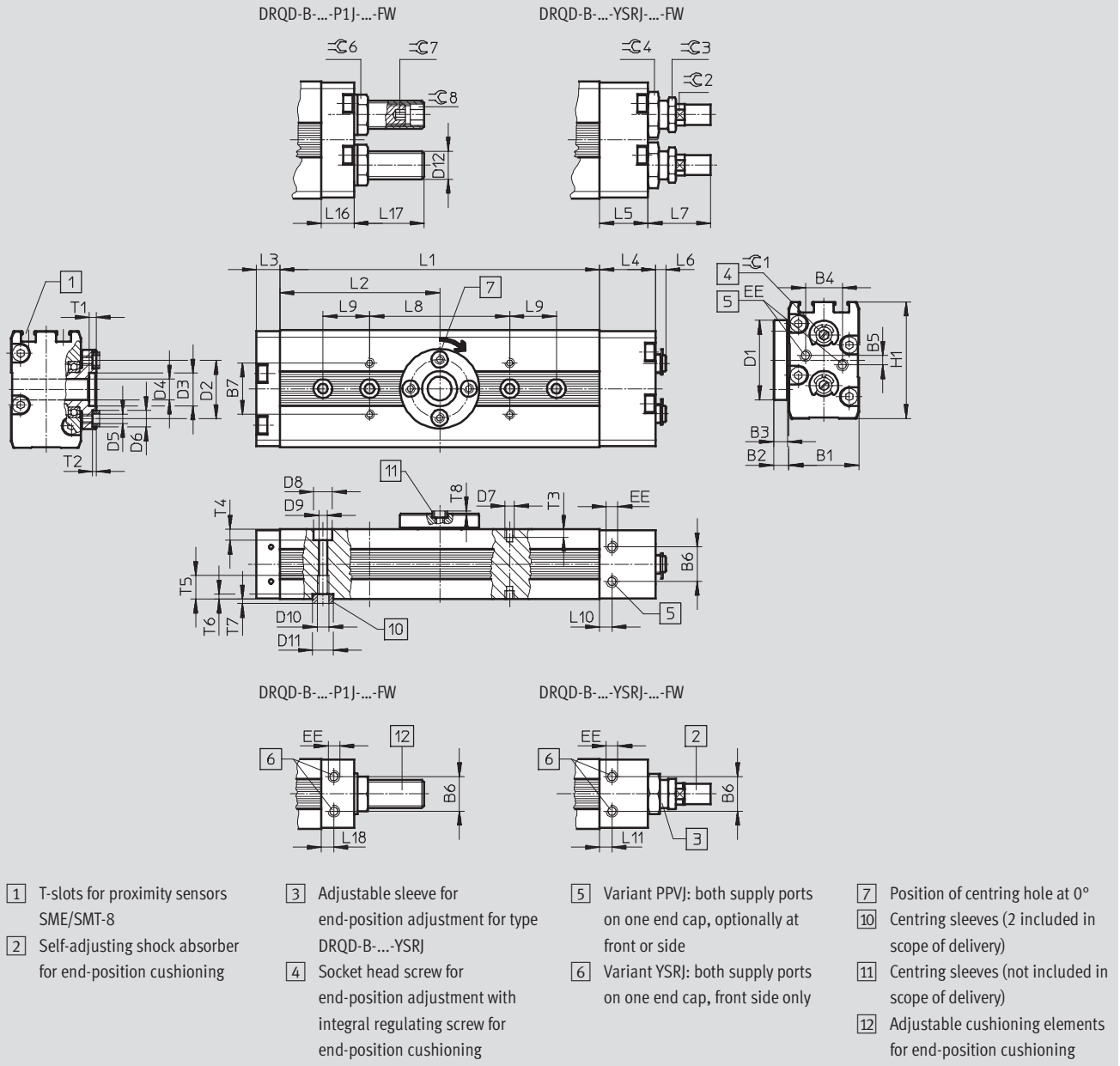

# Semi-rotary drives DRQD-B-16 ... 32, twin-pistons

Technical data

∅	Swivel angle	B1	B2	B3	B4	B5	B6	B7	D1	D2	D3	D4	D5	D6	D7	D8	D9	D10	D11
[mm]	[°]								∅	∅ ±0.025	∅ H8	∅		∅ H7		∅ H13	∅		∅ H7
16	90	30	6.5	6	17.8	4	14.8	22	34	25	14	9	M4	7	M4	8	4.2	M5	9
	180																		
	360																		
20	90	36	6.5	6	21.8	4	19.8	26	38	28	16	11	M4	7	M4	8	4.2	M5	9
	180																		
	360																		
25	90	42	9.5	9	24.8	4	24.8	30	48	34	16	12	M6	9	M5	10	5.3	M6	9
	180																		
	360																		
32	90	51	9.5	9	29.8	2	29.8	36	58	45	19	14	M6	9	M5	10	5.3	M6	9
	180																		
	360																		

∅	Swivel angle	D12	EE	H1	L1	L2	L3	L4	L5	L6		L7		L8	L9	L10	L11	L16
										min.	max.	min.	max.					
16	90	M12	M5	50	71	35.5	10	24	20.8	1.7	5.7	23.4	28.2	60	-	7.6	5.3	14
	180				93	46.5									-			
	360				137	68.5									20			
20	90	M14	M5	56	78.4	39.2	10	31.5	27	2.4	7	28.6	35.9	60	-	8	5	13.5
	180				104.8	52.4									-			
	360				157.6	78.8									20			
25	90	M16	M5	67	91.2	45.6	11	36.5	33	2.6	8.9	42	50.2	60	-	11	5	15
	180				124	62									-			
	360				189.2	94.6									20			
32	90	M22	G $\frac{1}{8}$	79	114.8	57.4	13	39	39	4.3	11.8	59.4	70.1	80	-	13.1	8	20
	180				155.6	77.8									20			
	360				237.4	118.7									20			

∅	Swivel angle	L17		L18	T1	T2	T3	T4	T5	T6	T7	T8	≈C1	≈C2	≈C3	≈C4	≈C6	≈C7	≈C8
		min.	max.																
16	90	6.7	41	5.8	3	1.6	3.5	5	10	2	2	1.4	4	9	13	17	15	4	8
	180																		
	360																		
20	90	8.5	59.5	5	3	1.6	3.5	5	12	2	2	1.4	7	11	15	19	17	4	8
	180																		
	360																		
25	90	9	61.4	5	3	2	5	6	12	2	2	2	7	15	19	24	19	5	10
	180																		
	360																		
32	90	10	60	8	3	2	5	6	14	2	2	2	8	20	27	32	27	5	10
	180																		
	360																		

# Semi-rotary drives DRQD-40 ... 50, twin-pistons

Technical data

FESTO

## Dimensions

Download CAD Data → [www.festo.com/us/cad](http://www.festo.com/us/cad)

FW – Flanged shaft

DRQD-...-YSRJ-...-FW

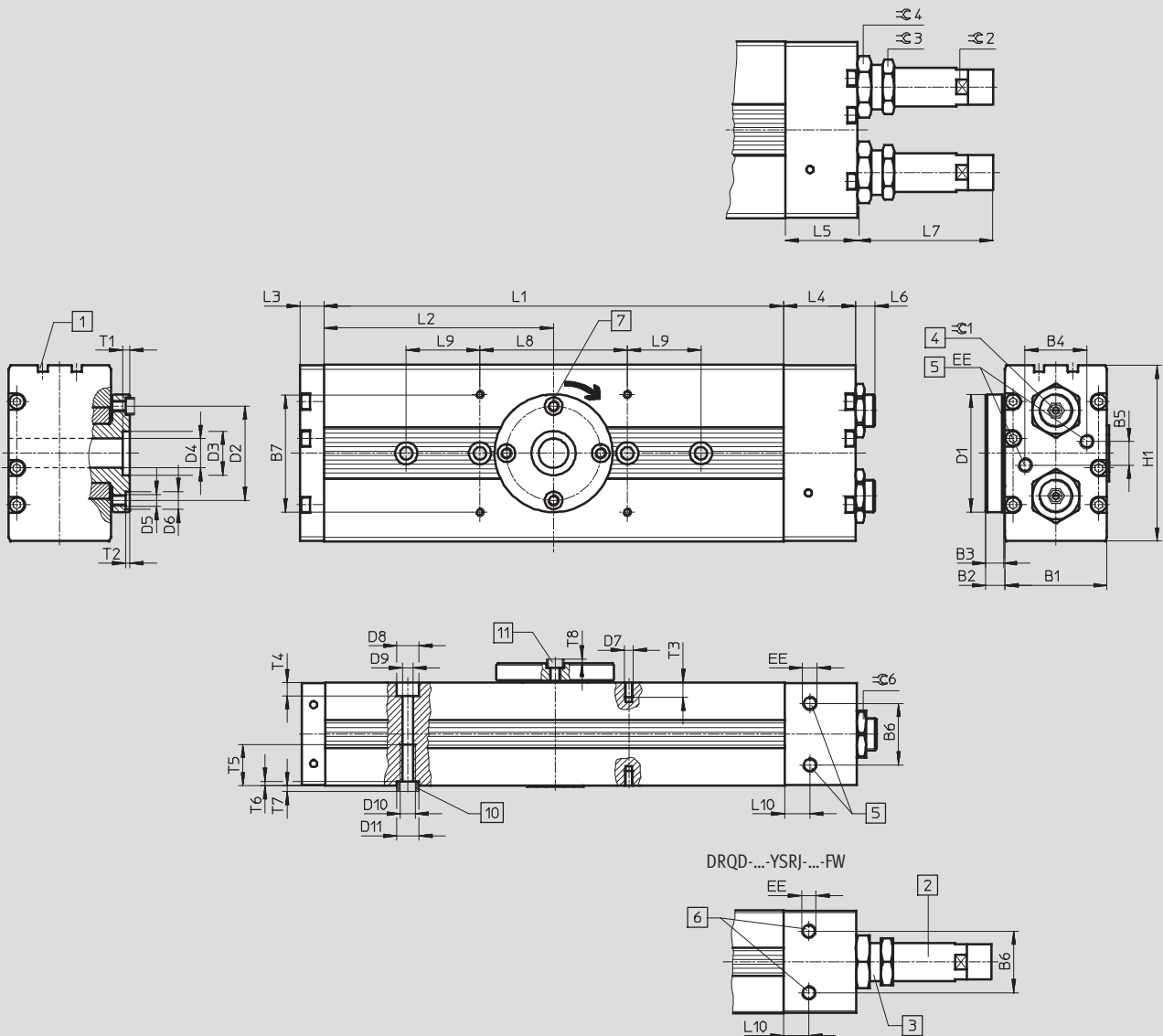

- |   |  |   |   |
|---|--|---|---|
| 1 T-slots for proximity sensors SME/SMT-8                   | 3 Adjustable sleeve for end-position adjustment for type DRQD-...-YSRJ                                     | 5 Variant PPVJ: both supply ports on one end cap, optionally at front or side | 7 Woodruff key position at 0°                           |
| 2 Self-adjusting shock absorber for end-position cushioning | 4 Socket head screw for end-position adjustment with integral regulating screw for end-position cushioning | 6 Variant YSRJ: both supply ports on one end cap, front side only             | 10 Centring sleeves (2 included in scope of delivery)   |
|   |  |   | 11 Centring sleeves (not included in scope of delivery) |

# Semi-rotary drives DRQD-40 ... 50, twin-pistons

Technical data

∅ [mm]	Swivel angle [°]	B1	B2	B3	B4	B5	B6	B7	D1 ∅	D2 ∅ ±0.025	D3 ∅ H7	D4	D5	D6 ∅ H7	D7	D8 ∅ H13
40	90	70	13	12	42	4	42	80	80	64	30	20	M8	12	M6	15
	180															
	360															
50	90	86	13	12	50	16	50	80	85	64	30	24	M8	12	M6	15
	180															
	360															

∅ [mm]	Swivel angle [°]	D9 ∅	D10	D11 ∅ H7	EE	H1	L1	L2	L3	L4	L5	L6		L7	
												min.	max.	min.	max.
40	90	8.5	M10	15	G $\frac{1}{8}$	120	146.8	73.4	16	49	41.5	5	14.6	85.1	96.4
	180						201.8	100.9							
	360						311.8	155.9							
50	90	8.5	M10	15	G $\frac{1}{4}$	144	191.4	95.7	18	64	55	8	20.7	107.8	120.6
	180						262.8	131.4							
	360						405.8	202.9							

∅ [mm]	Swivel angle [°]	L8 ±0.03	L9 ±0.03	L10	T1	T2	T3	T4	T5	T6	T7	≈C1	≈C2	≈C3	≈C4	≈C6
40	90	100	-	17	4	2.7	10	10	28	3	3	10	24	32	36	27
	180		-													
	360		50													
50	90	100	-	21.2	4	2.7	10	11	28	3	3	14	28	36	46	41
	180		50													
	360		100													

# Semi-rotary drives DRQD-B-16 ... 32, twin-pistons

Technical data

FESTO

## Dimensions

Download CAD Data → [www.festo.com/us/cad](http://www.festo.com/us/cad)

Z1 – Intermediate position module (energy through-feed is optional)

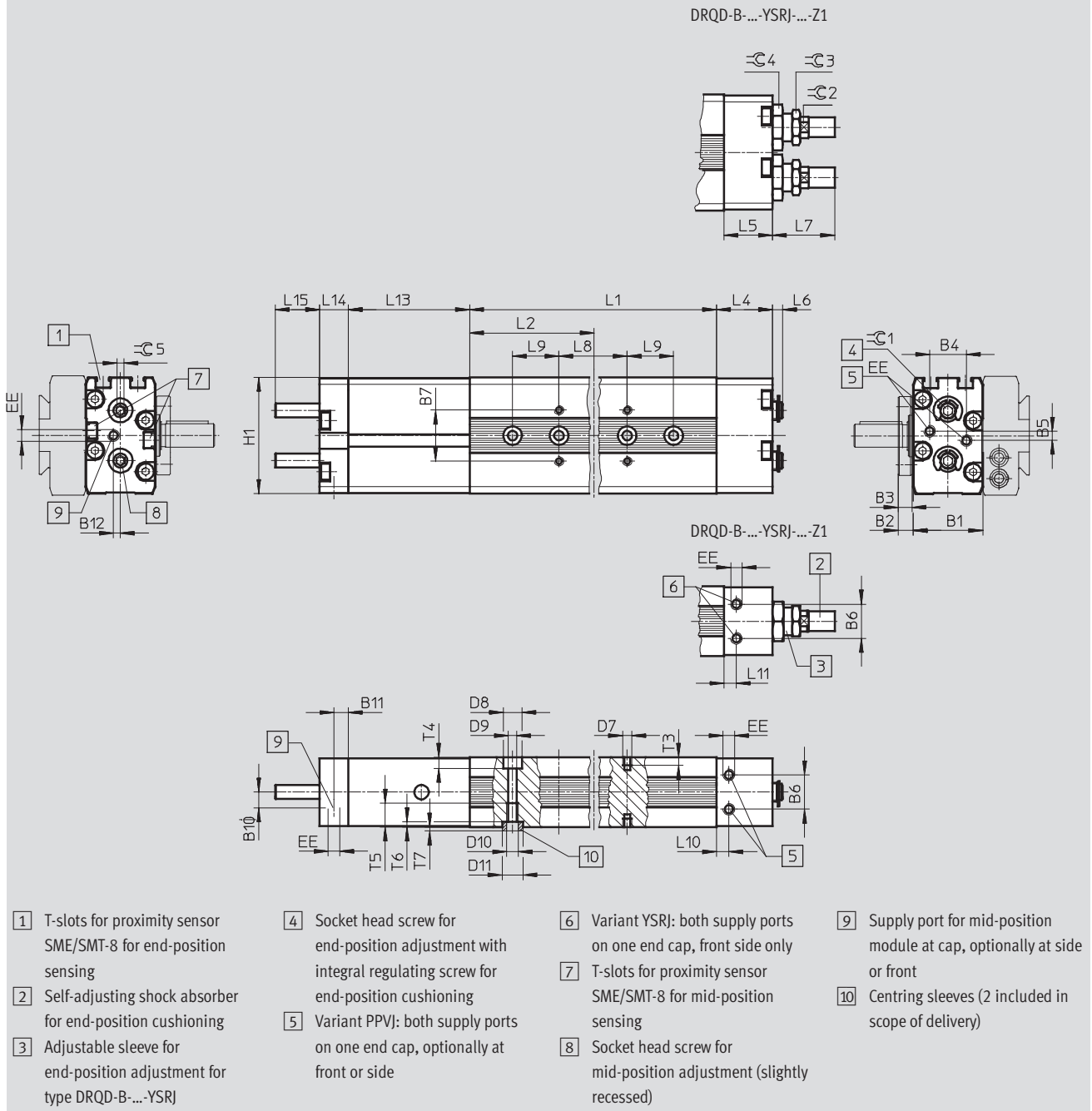

# Semi-rotary drives DRQD-B-16 ... 32, twin-pistons

Technical data

∅ [mm]	Swivel angle [°]	B1	B2	B3	B4	B5	B6	B7	B10	B11	B12	D7	D8 ∅ H13	D9 ∅	D10	D11 ∅ H7
16	90	30	6.5	6	17.8	4	14.8	22	6.4	4.5	3	M4	8	4.2	M5	9
	180															
20	90	36	6.5	6	21.8	4	19.8	26	6.5	4.5	5.6	M4	8	4.2	M5	9
	180															
25	90	42	9.5	9	24.8	4	24.8	30	9.1	6.9	8.2	M5	10	5.3	M6	9
	180															
32	90	51	9.5	9	29.8	2	29.8	36	9	8	9	M5	10	5.3	M6	9
	180															

∅ [mm]	Swivel angle [°]	EE	H1	L1	L2	L4	L5	L6		L7		L8 ±0.03	L9 ±0.03	L10	L11
								min.	max.	min.	max.				
16	90	M5	50	71	35.5	24	20.8	1.7	5.7	23.4	28.2	60	-	7.6	5.3
	180			93	46.5								-		
20	90	M5	56	78.4	39.2	31.5	27	2.4	7	28.6	35.9	60	-	8	5
	180			104.8	52.4								-		
25	90	M5	67	91.2	45.6	36.5	33	2.6	8.9	42	50.2	60	-	11	5
	180			124	62								-		
32	90	G $\frac{1}{8}$	79	114.8	57.4	39	39	4.3	11.8	59.4	70.1	80	-	13.1	8
	180			155.6	77.8								20		

∅ [mm]	Swivel angle [°]	L13	L14	L15		T3	T4	T5	T6	T7	≈C1	≈C2	≈C3	≈C4	≈C5
				min.	max.										
16	90	52.2	12.3	0	19.1	3.5	5	10	2	2	4	9	13	17	3
	180														
20	90	55.4	12.3	0	21.8	3.5	5	12	2	2	7	11	15	19	3
	180														
25	90	62.1	15	0	26	5	6	12	2	2	7	15	19	24	4
	180														
32	90	68.2	15.5	0	31.5	5	6	14	2	2	8	20	27	32	4
	180														

# Semi-rotary drives DRQD-40 ... 50, twin-pistons

Technical data

FESTO

## Dimensions

Download CAD Data → [www.festo.com/us/cad](http://www.festo.com/us/cad)

Z1 – Intermediate position module (energy through-feed is optional)

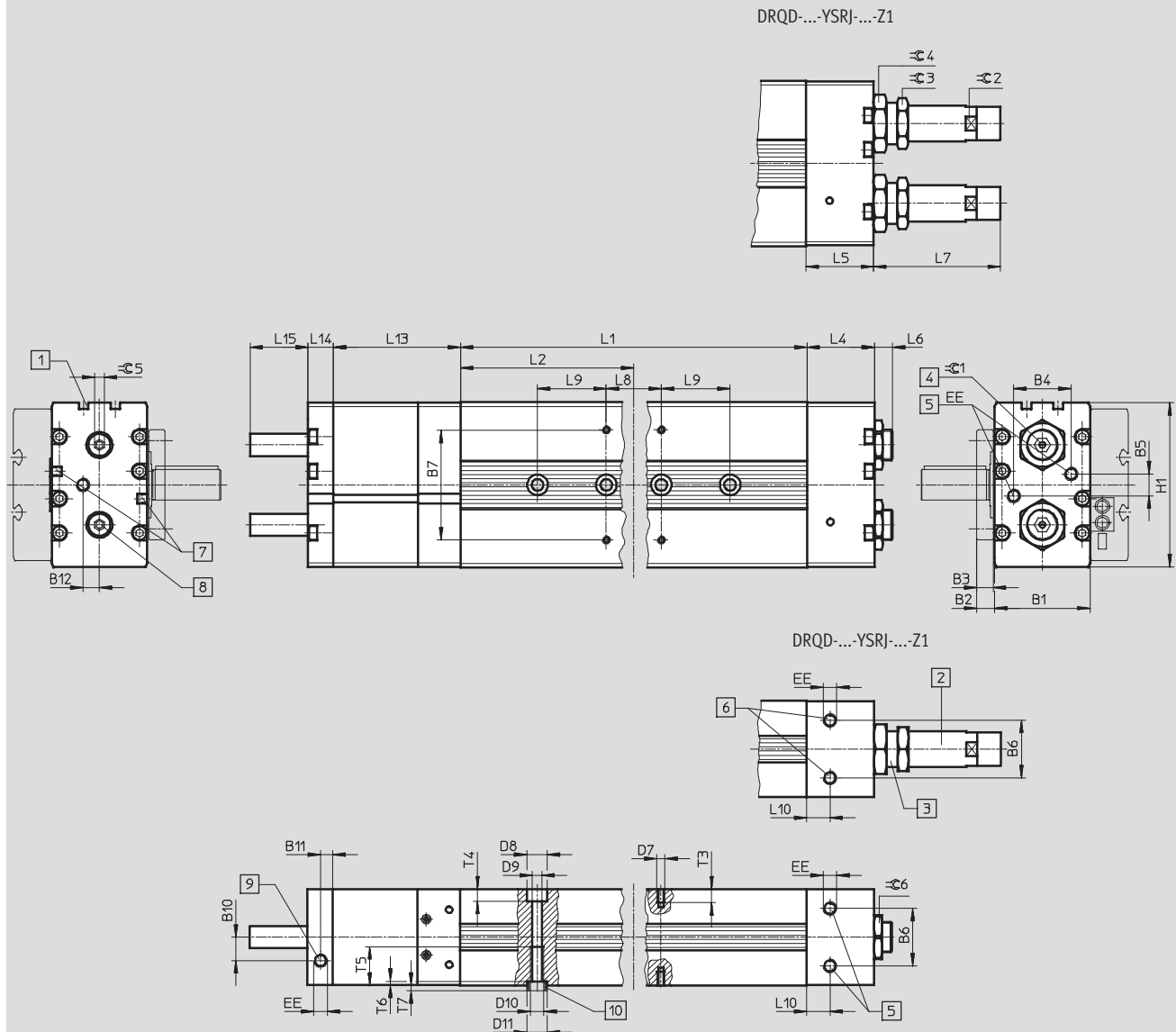

- |   |  |  |   |
|---|--|--|---|
| <p>1 T-slots for proximity sensor SME/SMT-8 for end-position sensing</p> <p>2 Self-adjusting shock absorber for end-position cushioning</p> <p>3 Adjustable sleeve for end-position adjustment for type DRQD-...-YSRJ</p> | <p>4 Socket head screw for end-position adjustment with integral regulating screw for end-position cushioning</p> <p>5 Variant PPVJ: both supply ports on one end cap, optionally at front or side</p> | <p>6 Variant YSRJ: both supply ports on one end cap, front side only</p> <p>7 T-slots for proximity sensor SME/SMT-8 for mid-position sensing</p> <p>8 Socket head screw for mid-position adjustment (slightly recessed)</p> | <p>9 Supply port for mid-position module at cap, optionally at side or front</p> <p>10 Centring sleeves (2 included in scope of delivery)</p> |
|---|--|--|---|



# Semi-rotary drives DRQD-40 ... 50, twin-pistons

Technical data

∅ [mm]	Swivel angle [°]	B1	B2	B3	B4	B5	B6	B7	B10	B11	B12	D7	D8 ∅ H13	D9 ∅	D10
40	90	70	13	12	42	4	42	80	92.5	9	12	M6	15	8.5	M10
	180														
	360														
50	90	86	13	12	50	16	50	80	105.7	9	14	M6	15	8.5	M10
	180														
	360														

∅ [mm]	Swivel angle [°]	D11 ∅ H7	EE	H1	L1	L2	L4	L5	L6		L7		L8 ±0.03	L9 ±0.03	L10
									min.	max.	min.	max.			
40	90	15	G $\frac{1}{8}$	120	146.8	73.4	49	41.5	5	14.6	85.1	96.4	100	-	17
	180				201.8	100.9								-	
	360				311.8	155.9								50	
50	90	15	G $\frac{1}{4}$	144	191.4	95.7	64	55	8	20.7	107.8	120.6	100	-	21.2
	180				262.8	131.4								50	
	360				405.8	202.9								100	

∅ [mm]	Swivel angle [°]	L13	L14	L15		T3	T4	T5	T6	T7	≈C1	≈C2	≈C3	≈C4	≈C5	≈C6
				min.	max.											
40	90	92.5	18.5	0	41.95	10	10	28	3	3	10	24	32	36	7	27
	180															
	360															
50	90	105.7	20.5	0	52.95	10	11	28	3	3	14	28	36	46	7	41
	180															
	360															

# Semi-rotary drives DRQD-B-16 ... 32, twin-pistons

Technical data

FESTO

## Dimensions

Download CAD Data → [www.festo.com/us/cad](http://www.festo.com/us/cad)

FW-SD – Energy through-feed

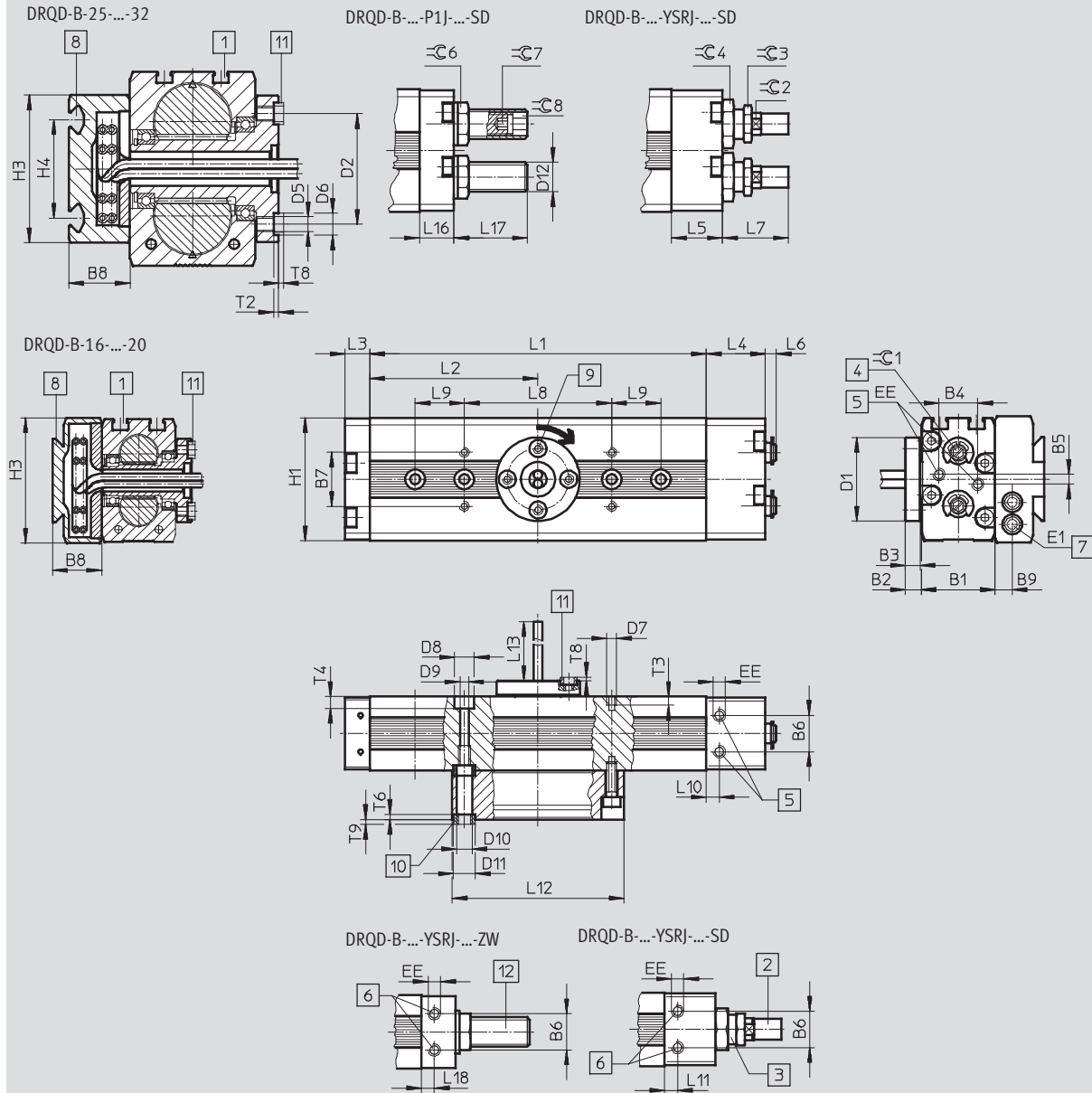

- |   |  |  |   |
|---|--|--|---|
| <p>1 T-slots for proximity sensors SME/SMT-8</p> <p>2 Self-adjusting shock absorber for end-position cushioning</p> <p>3 Adjustable sleeve for end-position adjustment for type DRQD-B-...-YSRJ</p> | <p>4 Socket head screw for end-position adjustment with integral regulating screw for end-position cushioning</p> <p>5 Variant PPVJ: both supply ports on one end cap, optionally at front or side</p> | <p>6 Variant YSRJ: both supply ports on one end cap, front side only</p> <p>7 Supply port for energy through-feed</p> <p>8 Mounting option via dovetail profile (for <math>\varnothing</math> 16 to 20 mm) or profile slot nut (grid dimensions 40 mm for <math>\varnothing</math> 25 to 32 mm)<br/>→ 64</p> | <p>9 Position of designated centring hole at 0°</p> <p>10 Centring sleeves (2 included in scope of delivery)<br/>→ 64</p> <p>11 Centring sleeves (not included in scope of delivery)</p> <p>12 Adjustable cushioning elements for end-position cushioning</p> |
|---|--|--|---|

# Semi-rotary drives DRQD-B-16 ... 32, twin-pistons

Technical data

∅ [mm]	Swivel angle [°]	B1	B2	B3	B4	B5	B6	B7	B8	B9	D1 ∅	D2 ∅ ±0.025	D5	D6 ∅ H7	D7	D8 ∅ H13	D9 ∅	D10 ∅ H13	D11 ∅ H7
16	90	30	6.5	6	17.8	4	14.8	22	20	7	34	25	M4	7	M4	8	4.2	5.5	9
	180																		
	360																		
20	90	36	6.5	6	21.8	4	19.8	26	20	7	38	28	M4	7	M4	8	4.2	5.5	9
	180																		
	360																		
25	90	42	9.5	9	24.8	4	24.8	30	25	7	48	34	M6	9	M5	10	5.3	6.6	9
	180																		
	360																		
32	90	51	9.5	9	29.8	2	29.8	36	25	7	58	45	M6	9	M5	10	5.3	6.6	9
	180																		
	360																		

∅ [mm]	Swivel angle [°]	D12	EE	E1 ∅	H1	H3	H4	L1	L2	L3	L4	L5	L6		L7		L8 ±0.03	L9 ±0.03	L10
													min.	max.	min.	max.			
16	90	M12	M5	4	50	51	-	71	35.5	10	24	20.8	1.7	5.7	23.4	28.2	60	-	7.6
	180							93	46.5									-	
	360							137	68.5									20	
20	90	M14	M5	4	56	51	-	78.4	39.2	10	31.5	27	2.4	7	28.6	35.9	60	-	8
	180							104.8	52.4									-	
	360							157.6	78.8									20	
25	90	M16	M5	4	67	60	40	91.2	45.6	11	36.5	33	2.6	8.9	42	50.2	60	-	11
	180							124	62									-	
	360							189.2	94.6									20	
32	90	M22	G1/8	4	79	60	40	114.8	57.4	13	39	39	4.3	11.8	59.4	70.1	80	-	13.1
	180							155.6	77.8									20	
	360							237.4	118.7									20	

∅ [mm]	Swivel angle [°]	L11	L12	L13 min.	L16	L17		L18	T2	T3	T4	T6	T8	T9	=C1	=C2	=C3	=C4	=C6	=C7	=C8
						min.	max.														
16	90	5.3	72	255	14	6.7	41	5.8	1.6	3.5	5	2.1	1.4	2	4	9	13	17	15	4	8
	180																				
	360																				
20	90	5	72	250	13.5	8.5	59.5	5	1.6	3.5	5	2.1	1.4	2	7	11	15	19	17	4	8
	180																				
	360																				
25	90	5	95	240	15	9	61.4	5	2	5	6	2.1	2	2	7	15	19	24	19	5	10
	180																				
	360																				
32	90	8	95	230	20	10	60	8	2	5	6	2.1	2	2	8	20	27	32	27	5	10
	180																				
	360																				

# Semi-rotary drives DRQD-40 ... 50, twin-pistons

Technical data

FESTO

## Dimensions

Download CAD Data → [www.festo.com/us/cad](http://www.festo.com/us/cad)

FW-SD – Energy through-feed

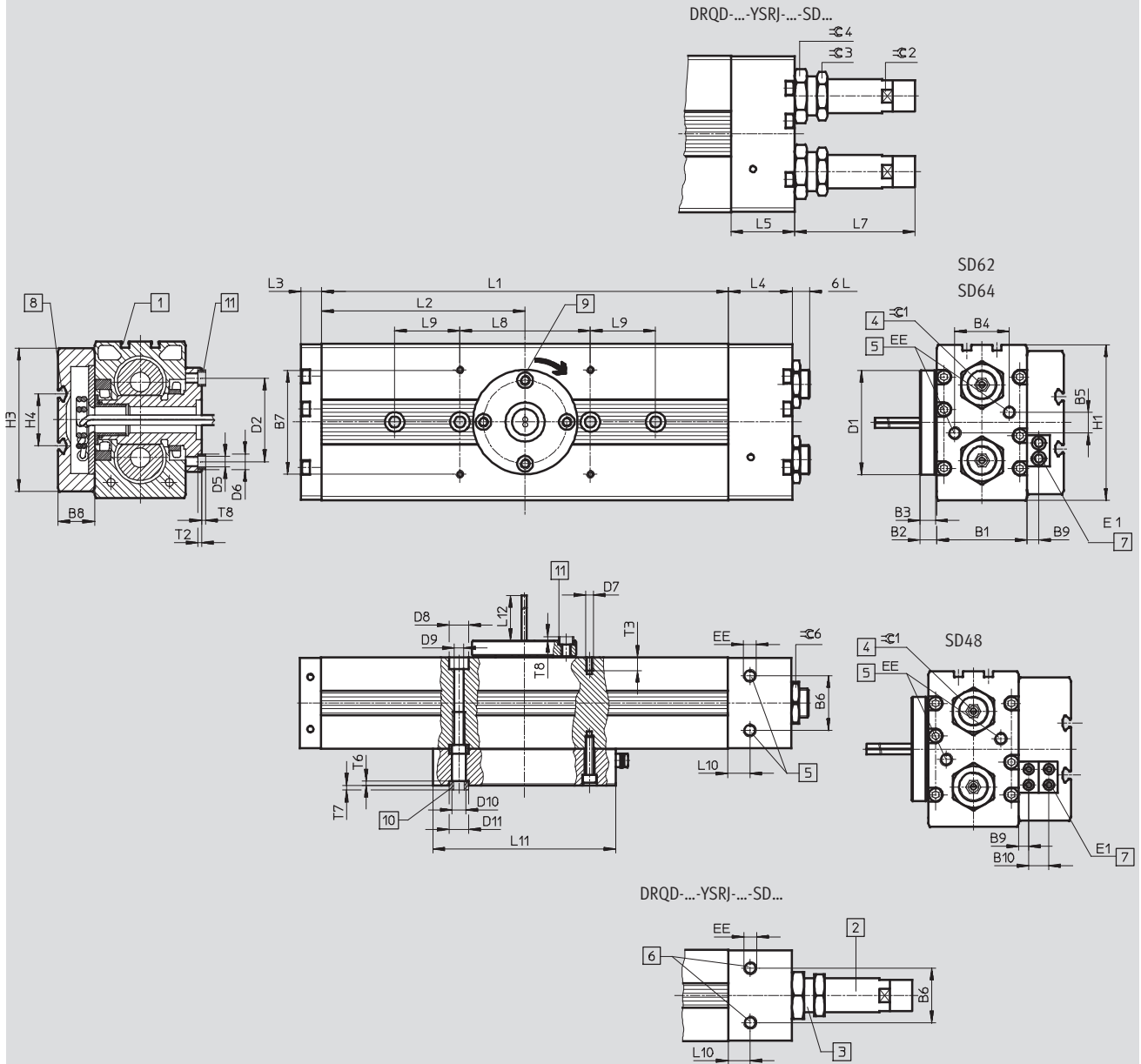

- |   |   |  |  |
|---|---|--|--|
| <p>1 T-slots for proximity sensors SME/SMT-8</p> <p>2 Self-adjusting shock absorber for end-position cushioning</p> <p>3 Adjustable sleeve for end-position adjustment for type DRQD-...-YSRJ</p> | <p>4 Socket head screw for end-position adjustment with integral regulating screw for end-position cushioning</p> <p>5 Variant PPV: both supply ports on one end cap, optionally at front or side</p> | <p>6 Variant YSRJ: both supply ports on one end cap, front side only</p> <p>7 Supply port for energy through-feed</p> <p>8 Mounting option via profile slot nut (grid dimensions 40 mm) → 64</p> | <p>9 Position of designated centring hole at 0°</p> <p>10 Centring sleeves (2 included in scope of delivery) → 64</p> <p>11 Centring sleeves (not included in scope of delivery)</p> |
|---|---|--|--|

# Semi-rotary drives DRQD-40 ... 50, twin-pistons

Technical data

∅ [mm]	Swivel angle [°]	Variant	B1	B2	B3	B4	B5	B6	B7	B8	B9	B10	D1 ∅	D2 ∅ ±0.05	D3 ∅ H7	D4 ∅	D5	D6 ∅ H7	D7	D8 ∅ H13
40	90	SD62/SD64	70	13	12	42	4	42	80	28	9	–	80	64	30	20	M8	12	M6	15
		SD48								40	7.75	15.5								
	180	SD62/SD64	70	13	12	42	4	42	80	28	9	–	80	64	30	20	M8	12	M6	15
		SD48								40	7.75	15.5								
	360	SD62/SD64	70	13	12	42	4	42	80	28	9	–	80	64	30	20	M8	12	M6	15
		SD48								40	7.75	15.5								
50	90	SD62/SD64	86	13	12	50	16	50	80	28	9	–	85	64	30	24	M8	12	M6	15
		SD48								40	7.75	15.5								
	180	SD62/SD64	86	13	12	50	16	50	80	28	9	–	85	64	30	24	M8	12	M6	15
		SD48								40	7.75	15.5								
	360	SD62/SD64	86	13	12	50	16	50	80	28	9	–	85	64	30	24	M8	12	M6	15
		SD48								40	7.75	15.5								

∅ [mm]	Swivel angle [°]	Variant	D9 ∅	D10 ∅	D11 ∅ H7	EE	E1	H1	H3	H4	L1	L2	L3	L4	L5	L6		L7	
																	min.	max.	min.
40	90	SD62/SD64	8.5	M10	15	G1/8	6	120	110	40	146.8	73.4	16	49	41.5	5	14.6	85.1	96.4
		SD48					4												
	180	SD62/SD64	8.5	M10	15	G1/8	6	120	110	40	201.8	100.9	16	49	41.5	5	14.6	85.1	96.4
		SD48					4												
	360	SD62/SD64	8.5	M10	15	G1/8	6	120	110	40	311.8	155.9	16	49	41.5	5	14.6	85.1	96.4
		SD48					4												
50	90	SD62/SD64	8.5	M10	15	G1/4	6	144	110	40	191.4	95.7	18	64	55	8	20.7	107.8	120.6
		SD48					4												
	180	SD62/SD64	8.5	M10	15	G1/4	6	144	110	40	262.8	131.4	18	64	55	8	20.7	107.8	120.6
		SD48					4												
	360	SD62/SD64	8.5	M10	15	G1/4	6	144	110	40	405.8	202.9	18	64	55	8	20.7	107.8	120.6
		SD48					4												

∅ [mm]	Swivel angle [°]	Variant	L8	L9	L10	L11	L12	T1	T2	T3	T4	T5	T6	T7	T8	∅C1	∅C2	∅C3	∅C4	∅C6
			±0.03	±0.03					min.											
40	90	SD62/SD64	100	–	17	140	42	4	2.7	10	10	28	3	3	2.3	10	24	32	36	27
		SD48																		
	180	SD62/SD64	100	–	17	140	42	4	2.7	10	10	28	3	3	2.3	10	24	32	36	27
		SD48																		
	360	SD62/SD64	100	50	17	140	42	4	2.7	10	10	28	3	3	2.3	10	24	32	36	27
		SD48																		
50	90	SD62/SD64	100	–	21.2	140	26	4	2.7	10	11	28	3	3	2.3	14	28	36	46	41
		SD48																		
	180	SD62/SD64	100	50	21.2	140	26	4	2.7	10	11	28	3	3	2.3	14	28	36	46	41
		SD48																		
	360	SD62/SD64	100	100	21.2	140	26	4	2.7	10	11	28	3	3	2.3	14	28	36	46	41
		SD48																		

# Semi-rotary drives DRQD-B-16 ... 20, twin-pistons

Technical data

FESTO

## Dimensions

Download CAD Data → [www.festo.com/us/cad](http://www.festo.com/us/cad)

FW E422 – Energy through-feed

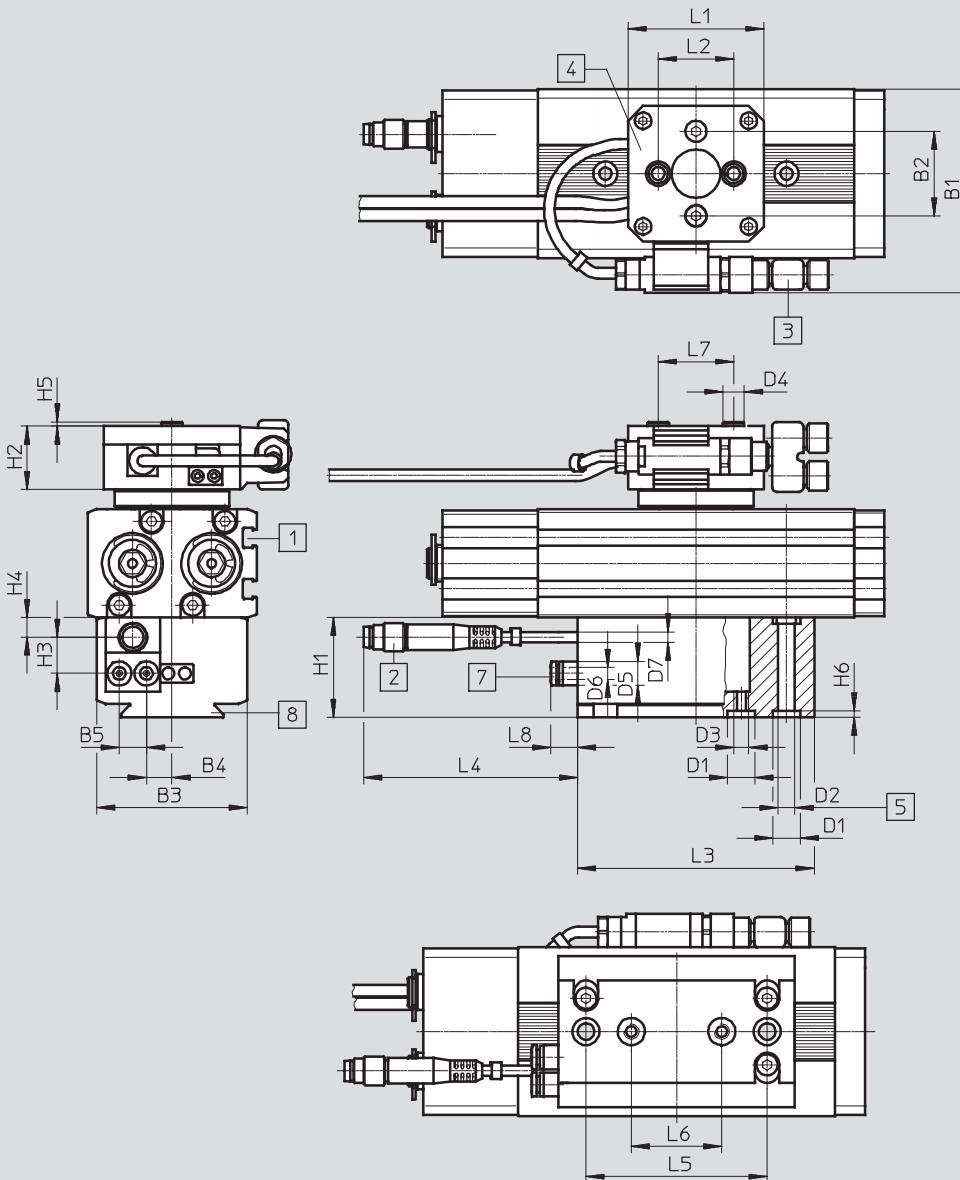

- 1 T-slots for proximity sensors SME/SMT-8
- 2 Plug M8x1, 4-pin
- 3 Socket M8x1 for proximity sensor SME/SMT
- 4 Output plate can be repositioned by 90°

- 5 Screw-through option with screw M4
- 7 Supply port for energy through-feed for tubing O.D. 4 mm
- 8 Mounting option via dovetail connection

Basic dimensions  
→ 42

## Semi-rotary drives DRQD-B-16 ... 20, twin-pistons

FESTO

Technical data

∅	B1	B2	B3	B4	B5	D1	D2	D3	D4	D5	D6	D7
[mm]		±0,02	+0,4		±0,2	∅ H7	∅		∅ h7	∅	∅	∅
16	64	28	50	8,5	9	9	5,5	M5	7	8	4	3,5
20		25										

∅	H1	H2	H3	H4	H5	H6	L1	L2	L3	L4	L5	L6	L7	L8
[mm]	+0,2	+0,2		±0,5		±0,1		±0,02	±0,2		±0,02	±0,02	±0,02	
16	33	21	12	6,5	1,4	2,1	45	25	78,4	70	60	30	25	10
20								28						

# Semi-rotary drives DRQD-B-25 ... 32, twin-pistons

Technical data

FESTO

## Dimensions

Download CAD Data → [www.festo.com/us/cad](http://www.festo.com/us/cad)

FW-E444 – Energy through-feed

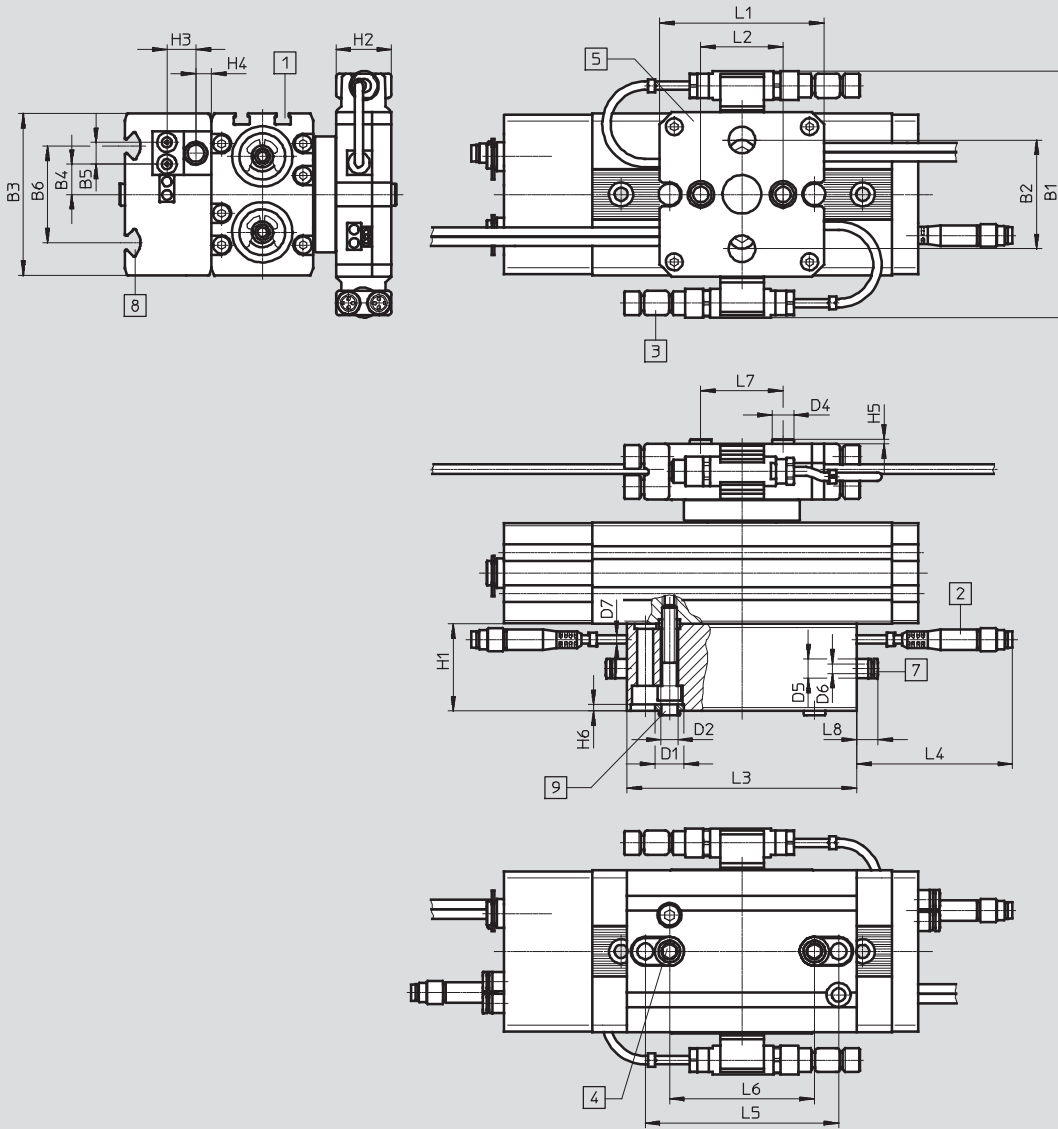

- 1 T-slots for proximity sensors SME/SMT-8
- 2 Plug M8x1, 4-pin
- 3 Socket M8x1 for proximity sensor SME/SMT

- 4 Mounting via through-holes possible with screw M5 (retaining screws must be removed beforehand)
- 5 Centring hole can be repositioned by 90°

- 7 Supply port for energy through-feed for tubing O.D. 6 mm
- 8 Mounting option via profile slot nut
- 9 Centring sleeves (2 pieces included in scope of delivery) → 64

Basic dimensions  
→ 42



# Semi-rotary drives DRQD-B-25 ... 32, twin-pistons

Technical data

∅	B1	B2	B3	B4	B5	B6	D1	D2	D4	D5	D6	D7
[mm]		±0,02	+0,3		±0,2	±0,5	∅ H7	∅ H13	∅ h7	∅	∅	∅
25	102	34	67	12,5	9	40	12	6,6	9	8	4	3,5
32		45										

∅	H1	H2	H3	H4	H5	H6	L1	L2	L3	L4	L5	L6	L7	L8
[mm]	+0,15	+0,2		±0,5		±0,1		±0,02	±0,2		±0,02	±0,02	±0,02	
25	36	23	12	6,5	2	2,6	68	34	95	65	80	60	34	10
32								45						

# Semi-rotary drives DRQD-40 ... 50, twin-pistons

Technical data

FESTO

## Dimensions

Download CAD Data → [www.festo.com/us/cad](http://www.festo.com/us/cad)

FW-E644 – Energy through-feed

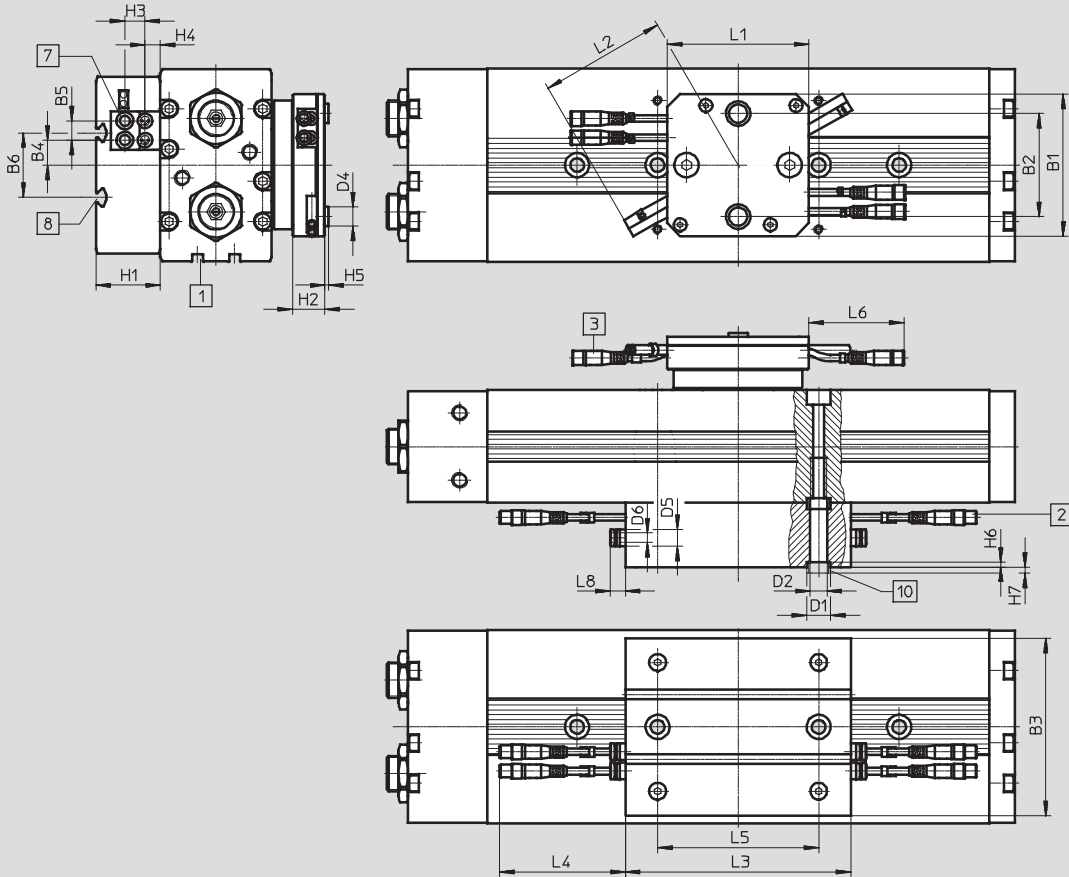

- 1 T-slots for proximity sensors SME/SMT-8
- 2 Plug M8x1
- 3 Socket M8x1
- 7 Supply port for energy through-feed for tubing O.D. 6 mm

- 8 Mounting option via profile slot nut (grid dimensions 40 mm) → 64
- 10 Centring sleeves (2 pieces included in scope of delivery) → 64



Basic dimensions  
→ 44

∅	B1	B2	B3	B4	B5	B6	D1	D2	D4	D5	D6
[mm]		±0,02	+0,2		±0,2	±0,5	∅ H7	∅ H13	∅ h7	∅	∅
40	88	64	110	15,5	12	40	15	10,5	12	10,5	6
50											

∅	H1	H2	H3	H4	H5	H6	H7	L1	L2	L3	L4	L5	L6	L8
[mm]	+0,2/-0,1	+0,2		±0,5		+0,15			min.			±0,03		±1
40	40	20	12,5	9,5	2,5	3	3	88	75	140	82	100	150	9,5
50													130	

# Semi-rotary drives DRQD-B-16 ... 32, DRQD-40 ... 50, twin-pistons

Technical data

Ordering data – Standard types				
DRQD	∅ [mm]	Swivel angle [°]	Part No.	Type
<b>PPVJ – Adjustable end-position cushioning</b>				
	AL – Connection on left			
	16	180	563341	DRQD-B-16-180-PPVJ-A-AL-FW
	20		563342	DRQD-B-20-180-PPVJ-A-AL-FW
	25		563343	DRQD-B-25-180-PPVJ-A-AL-FW
	32		563344	DRQD-B-32-180-PPVJ-A-AL-FW
	AR – Connection on right			
	16	90	563367	DRQD-B-16-90-PPVJ-A-AR-FW
	16	180	563353	DRQD-B-16-180-PPVJ-A-AR-FW
	20		563354	DRQD-B-20-180-PPVJ-A-AR-FW
	25		563355	DRQD-B-25-180-PPVJ-A-AR-FW
	32		563356	DRQD-B-32-180-PPVJ-A-AR-FW
	<b>P1J – Adjustable flexible cushioning elements</b>			
	AL – Connection on left			
	16	180	1177954	DRQD-B-16-180-P1J-A-AL-FW
	20		1177955	DRQD-B-20-180-P1J-A-AL-FW
	25		1177956	DRQD-B-25-180-P1J-A-AL-FW
	32		1177957	DRQD-B-32-180-P1J-A-AL-FW
	AR – Connection on right			
	16	180	1177950	DRQD-B-16-180-P1J-A-AR-FW
	20		1177951	DRQD-B-20-180-P1J-A-AR-FW
	25		1177952	DRQD-B-25-180-P1J-A-AR-FW
	32		1177953	DRQD-B-32-180-P1J-A-AR-FW
<b>YSRJ – Adjustable shock absorbers</b>				
	AL – Connection on left			
	16	180	563337	DRQD-B-16-180-YSRJ-A-AL-FW
	20		563338	DRQD-B-20-180-YSRJ-A-AL-FW
	25		563339	DRQD-B-25-180-YSRJ-A-AL-FW
	32		563340	DRQD-B-32-180-YSRJ-A-AL-FW
	AR – Connection on right			
	16	180	563349	DRQD-B-16-180-YSRJ-A-AR-FW
	20		563350	DRQD-B-20-180-YSRJ-A-AR-FW
	25		563351	DRQD-B-25-180-YSRJ-A-AR-FW
	32		563352	DRQD-B-32-180-YSRJ-A-AR-FW

# Semi-rotary drives DRQD-B-16 ... 32, twin-pistons

Ordering data – Modular products

**M** Mandatory data →

Module No.	Function	Product design	Size	Swivel angle	Cushioning	Position sensing	Pneumatic connection	Output shaft
563 345	DRQD	B	16	90	PPVJ	A	AL	ZW
563 346			20	180	P1J		AR	FW
563 347			25	360	YSRJ			
563 348			32	1 ... 340				
<b>Ordering example</b>								
563348	DRQD	- B	- 32	- 280	- YSRJ	- A	- AR	- FW

**Ordering table**

Size	16	20	25	32	Conditions	Code	Enter code
<b>M</b> Module No.	563 345	563 346	563 347	563 348			
Function	Semi-rotary drive with twin pistons					DRQD	DRQD
Product design	Function-optimized					-B	-B
Piston Ø [mm]	16	20	25	32		-...	
Swivel angle (standard)	90°					-90	
Adjusting range +6°/-20° (not preset)	180°					-180	
	360°				[1]	-360	
X-rotation angle	1° ... 70°, with centre section 90°					-...	
Adjusting range ±6°	100° ... 160°, with centre section 180°					-...	
Angle preset ±1°	190° ... 340°, with centre section 360°				[1]	-...	
Cushioning	Adjustable end-position cushioning					-PPVJ	
	Adjustable shock absorbers					-YSRJ	
	Adjustable flexible cushioning elements				[2]	-P1J	
Position sensing	For proximity sensing					-A	-A
Pneumatic connection	Connection on left					-AL	
	Connection on right					-AR	
Output shaft	Spigot shaft				[3]	-ZW	
	Flanged shaft				[4]	-FW	

[1] 190 ... 360 Not with energy through-feed E422, E444

[2] P1J Not with Z1, only with standard swivel angle (90°, 180°, 360°)

[3] ZW Not with energy through-feed SD32, SD42, E422, E444

[4] FW Required for energy through-feed SD32, SD42, E422, E444

Transfer order code

DRQD -  B -  -  -  A -  -

# Semi-rotary drives DRQD-B-16 ... 32, twin-pistons

Ordering data – Modular products

→ **0** Options

<b>Intermediate position</b>	<b>Energy through-feed</b>	<b>User's manual</b>
Z1	SD32 SD42 E422 E444	B E F S I V
-	- <b>SD42</b> -	- <b>B</b> -

Ordering table							
Size	16	20	25	32	Conditions	Code	Enter code
<b>0</b> Intermediate position	1 intermediate position (mid-position)				<b>5</b>	<b>-Z1</b>	
Energy through-feed	2x tubing O.D. 3 mm					<b>-SD32</b>	
	2x tubing O.D. 4 mm					<b>-SD42</b>	
	2x tubing O.D. 4 mm, 1x 4-pin cable to 2x 3-pin cable		-	-		<b>-E422</b>	
	-	-	4x tubing O.D. 4 mm, 2x 4-pin cable to 4x 3-pin cable			<b>-E444</b>	
Alternative language user documentation (standard is German)	No user manual to be included					<b>-B</b>	
	User manual English					<b>-E</b>	
	User manual French					<b>-F</b>	
	User manual Spanish					<b>-S</b>	
	User manual Italian					<b>-I</b>	
	User manual Swedish					<b>-V</b>	

**5** **Z1** Cannot be combined with swivel angle (standard) 360° and X swivel angle

Transfer order code

-  -  -

# Semi-rotary drives DRQD-40 ... 50, twin-pistons

Ordering data – Modular products

**M** Mandatory data →

Module No.	Function	Size	Swivel angle	Cushioning	Position sensing	Pneumatic connection	Output shaft
197 373	DRQD	40	90	PPVJ	A	AL	ZW
197 374		50	180 360 1 ... 340	YSRJ		AR	FW
<b>Ordering example</b>							
<b>197 373</b>	<b>DRQD</b>	<b>- 40</b>	<b>- 280</b>	<b>- YSRJ</b>	<b>- A</b>	<b>- AR</b>	<b>- FW</b>

**Ordering table**

Size	40	50	Conditions	Code	Enter code
<b>M</b> Module No.	<b>197 373</b>		<b>197 374</b>		
Function	Semi-rotary drive with twin pistons				<b>DRQD</b>
Piston Ø [mm]	40	50		-...	
Swivel angle (standard)	90°			<b>-90</b>	
Adjusting range +6°/-20° (not preset)	180°			<b>-180</b>	
	360°		[1]	<b>-360</b>	
	1° ... 70°, with centre section 90°			-...	
Adjusting range ±6°	100° ... 160°, with centre section 180°			-...	
	190° ... 340°, with centre section 360°		[1]	-...	
Cushioning	Adjustable end-position cushioning			<b>-PPVJ</b>	
	Adjustable shock absorbers			<b>-YSRJ</b>	
Position sensing	For proximity sensing			<b>-A</b>	-A
Pneumatic connection	Connection on left			<b>-AL</b>	
	Connection on right			<b>-AR</b>	
Output shaft	Spigot shaft		[2]	<b>-ZW</b>	
	Flanged shaft		[3]	<b>-FW</b>	

[1] **190 ... 360** Not with energy through-feed E644

[2] **ZW** Not with energy through-feed SD48, SD62, SD64, E644

[3] **FW** Required for energy through-feed SD48, SD62, SD64, E644

Transfer order code

**DRQD** -  -  -  - **A** -  -

# Semi-rotary drives DRQD-40 ... 50, twin-pistons

Ordering data – Modular product system

→ **Options**

<b>Intermediate position</b>	<b>Energy through-feed</b>	<b>User's manual</b>
Z1	SD48 SD62 SD64 E644	B E F S I V
-	- <b>SD64</b> -	- <b>B</b> -

Ordering table					
Size	40	50	Conditions	Code	Enter code
0	Intermediate position	1 intermediate position (mid-position)	4	-Z1	
	Energy through-feed	8x tubing O.D. 4 mm		-SD48	
		2x tubing O.D. 6 mm		-SD62	
		4x tubing O.D. 6 mm		-SD64	
		4x tubing O.D. 6 mm, 4x 3-pin cable		-E644	
	Alternative language user documentation (standard is German)	No user manual to be included		-B	
		User manual English		-E	
		User manual French		-F	
		User manual Spanish		-S	
		User manual Italian		-I	
User manual Swedish			-V		

4 Z1 Cannot be combined with swivel angle (standard) 360° and X swivel angle





Transfer order code

-  -  -

# Semi-rotary drives DRQD/DRQD-B, twin pistons

Accessories

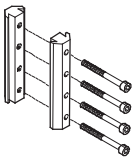
**FESTO**

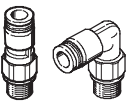
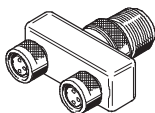
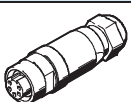
Ordering data						
	For Ø	Remarks	Design	Part No.	Type	PU <sup>1)</sup>
<b>Centring sleeve ZBH</b> <span style="float: right;">Technical data → Internet: zbh</span>						
	6	For centring the drive on attachments		<b>186 717</b>	<b>ZBH-7</b>	10
	8 ... 32			<b>150 927</b>	<b>ZBH-9</b>	
	40/50			<b>191 409</b>	<b>ZBH-15</b>	
	16/20	For centring attachments on the flanged shaft FW		<b>186 717</b>	<b>ZBH-7</b>	
	25/32			<b>150 927</b>	<b>ZBH-9</b>	
	40/50			<b>189 653</b>	<b>ZBH-12</b>	
<b>Connecting sleeve ZBV</b> <span style="float: right;">Technical data → Internet: zbv</span>						
	25 ... 32	For centring the semi-rotary drive with a drive		<b>548 806</b>	<b>ZBV-12-9</b>	1
<b>Adapter kit HMSV</b> <span style="float: right;">Technical data → Internet: hmsv</span>						
	16/20	Mounting via dovetail profile for variant with energy through-feed SD... and E...		<b>177 647</b>	<b>HMSV-1</b>	1
<b>Slot nut HMBN</b> <span style="float: right;">Technical data → Internet: hmbn</span>						
	25 ... 50	Mounting via profile slot nut for variant with energy through-feed SD... and E...		<b>547 264</b>	<b>HMBN-5-1M5</b>	10
				<b>186 566</b>	<b>HMBN-5-2M5</b>	
<b>Rotary push-in fitting</b> <span style="float: right;">Technical data → Internet: quick star</span>						
	6 ... 12 Only in combination with hollow bolt HS	With ball bearing, for standard O.D. tubing	Straight	<b>153 526</b>	<b>QSR-M5-4</b>	1
			L-shape	<b>153 529</b>	<b>QSRL-M5-4</b>	
<b>T-connector NEDU</b> <span style="float: right;">Technical data → Internet: nedu</span>						
	16 ... 32	Included in the scope of delivery if semi-rotary drive DRQD is ordered with energy through-feed E422 and E444. Suitable for connection of two proximity sensors SME/SMT-8 or SME/SMT-10		<b>544 391</b>	<b>NEDU-M8D3-M8T4</b>	1
<b>Cable socket NECU</b> <span style="float: right;">Technical data → Internet: necu</span>						
	16 ... 32	Included in the scope of delivery if semi-rotary drive DRQD is ordered with energy through-feed E422 and E444.		<b>544 392</b>	<b>NECU-M8G4</b>	1



1) Packaging unit quantity





# Semi-rotary drives DRQD/DRQD-B, twin pistons

Accessories

Ordering data – Proximity sensors for C-slot, magneto-resistive						Technical data → Internet: smt	
	Type of mounting	Switch output	Electrical connection, connection direction	Cable length [m]	Part No.	Type	
N/O contact							
	Insertable in the slot from above	PNP	Cable, 3-wire, in-line	2.5	551 373	SMT-10M-PS-24V-E-2,5-L-OE	
			Plug M8x1, 3-pin, in-line	0.3	551 375	SMT-10M-PS-24V-E-0,3-L-M8D	
			Plug M8x1, 3-pin, lateral	0.3	551 376	SMT-10M-PS-24V-E-0,3-Q-M8D	

Ordering data – Proximity sensors for C-slot, magnetic reed						Technical data → Internet: sme	
	Type of mounting	Switch output	Electrical connection, connection direction	Cable length [m]	Part No.	Type	
N/O contact							
	Insertable in the slot from above	Contacting	Plug M8x1, 3-pin, in-line	0.3	551 367	SME-10M-DS-24V-E-0,3-L-M8D	
			Cable, 3-wire, in-line	2.5	551 365	SME-10M-DS-24V-E-2,5-L-OE	
			Cable, 2-wire, in-line	2.5	551 369	SME-10M-ZS-24V-E-2,5-L-OE	
	Insertable in the slot lengthwise	Contacting	Plug M8x1, 3-pin, in-line	0.3	173 212	SME-10-SL-LED-24	
			Cable, 3-wire, in-line	2.5	173 210	SME-10-KL-LED-24	

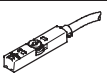
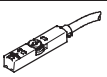

Ordering data – Connecting cables				Technical data → Internet: nebu			
	Electrical connection, left	Electrical connection, right	Cable length [m]	Part No.	Type		
	Straight socket, M8x1, 3-pin	Cable, open end, 3-wire	2.5	541 333	NEBU-M8G3-K-2.5-LE3		
			5	541 334	NEBU-M8G3-K-5-LE3		
	Angled socket, M8x1, 3-pin	Cable, open end, 3-wire	2.5	541 338	NEBU-M8W3-K-2.5-LE3		
			5	541 341	NEBU-M8W3-K-5-LE3		



Ordering data – Proximity sensors for T-slot, magneto-resistive						Technical data → Internet: smt	
	Type of mounting	Switch output	Electrical connection	Cable length [m]	Part No.	Type	
N/O contact							
	Insertable in the slot from above, flush with cylinder profile, short design	PNP	Cable, 3-wire	2.5	574335	SMT-8M-A-PS-24V-E-2,5-OE	
			Plug M8x1, 3-pin	0.3	574334	SMT-8M-A-PS-24V-E-0,3-M8D	
			Plug M12x1, 3-pin	0.3	574337	SMT-8M-A-PS-24V-E-0,3-M12	
		NPN	Cable, 3-wire	2.5	574338	SMT-8M-A-NS-24V-E-2,5-OE	
			Plug M8x1, 3-pin	0.3	574339	SMT-8M-A-NS-24V-E-0,3-M8D	
N/C contact							
	Insertable in the slot from above, flush with cylinder profile, short design	PNP	Cable, 3-wire	7.5	574340	SMT-8M-A-PO-24V-E-7,5-OE	

## Semi-rotary drives DRQD/DRQD-B, twin pistons

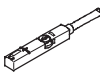
Accessories

FESTO

Ordering data – Proximity sensors for T-slot, magnetic reed					Technical data → Internet: sme	
	Type of mounting	Switch output	Electrical connection	Cable length [m]	Part No.	Type
<b>N/O contact</b>						
	Insertable in the slot from above, flush with cylinder profile	Contacting	Cable, 3-wire	2.5	<b>543 862</b>	<b>SME-8M-DS-24V-K-2,5-OE</b>
				5.0	<b>543 863</b>	<b>SME-8M-DS-24V-K-5,0-OE</b>
			Plug M8x1, 3-pin	2.5	<b>543 872</b>	<b>SME-8M-ZS-24V-K-2,5-OE</b>
				0.3	<b>543 861</b>	<b>SME-8M-DS-24V-K-0,3-M8D</b>
	Insertable in the slot lengthwise, flush with the cylinder profile	Contacting	Cable, 3-wire	2.5	<b>150 855</b>	<b>SME-8-K-LED-24</b>
			Plug M8x1, 3-pin	0.3	<b>150 857</b>	<b>SME-8-S-LED-24</b>
<b>N/C contact</b>						
	Insertable in the slot lengthwise, flush with the cylinder profile	Contacting	Cable, 3-wire	7.5	<b>160 251</b>	<b>SME-8-O-K-LED-24</b>

Ordering data – Connecting cables				Technical data → Internet: nebu	
	Electrical connection, left	Electrical connection, right	Cable length [m]	Part No.	Type
	Straight socket, M8x1, 3-pin	Cable, open end, 3-wire	2.5	<b>541 333</b>	<b>NEBU-M8G3-K-2.5-LE3</b>
			5	<b>541 334</b>	<b>NEBU-M8G3-K-5-LE3</b>
	Straight socket, M12x1, 5-pin	Cable, open end, 3-wire	2.5	<b>541 363</b>	<b>NEBU-M12G5-K-2.5-LE3</b>
			5	<b>541 364</b>	<b>NEBU-M12G5-K-5-LE3</b>
	Angled socket, M8x1, 3-pin	Cable, open end, 3-wire	2.5	<b>541 338</b>	<b>NEBU-M8W3-K-2.5-LE3</b>
			5	<b>541 341</b>	<b>NEBU-M8W3-K-5-LE3</b>
	Angled socket, M12x1, 5-pin	Cable, open end, 3-wire	2.5	<b>541 367</b>	<b>NEBU-M12W5-K-2.5-LE3</b>
			5	<b>541 370</b>	<b>NEBU-M12W5-K-5-LE3</b>

Ordering data – Slot cover for T-slot				
	Assembly	Length [m]	Part No.	Type
	insertable from above	2x 0.5	<b>151 680</b>	<b>ABP-5-S</b>

# Product Range and Company Overview

## A Complete Suite of Automation Services

Our experienced engineers provide complete support at every stage of your development process, including: conceptualization, analysis, engineering, design, assembly, documentation, validation, and production.



**Custom Automation Components**  
Complete custom engineered solutions



**Custom Control Cabinets**  
Comprehensive engineering support and on-site services



**Complete Systems**  
Shipment, stocking and storage services

## The Broadest Range of Automation Components

With a comprehensive line of more than 30,000 automation components, Festo is capable of solving the most complex automation requirements.



**Electromechanical**  
Electromechanical actuators, motors, controllers & drives



**Pneumatics**  
Pneumatic linear and rotary actuators, valves, and air supply



**PLCs and I/O Devices**  
PLC's, operator interfaces, sensors and I/O devices

## Supporting Advanced Automation... As No One Else Can!

Festo is a leading global manufacturer of pneumatic and electromechanical systems, components and controls for industrial automation, with more than 12,000 employees in 56 national headquarters serving more than 180 countries. For more than 80 years, Festo has continuously elevated the state of manufacturing with innovations and optimized motion control solutions that deliver higher performing, more profitable automated manufacturing and processing equipment. Our dedication to the advancement of automation extends beyond technology to the education and development of current and future automation and robotics designers with simulation tools, teaching programs, and on-site services.

## Quality Assurance, ISO 9001 and ISO 14001 Certifications

Festo Corporation is committed to supply all Festo products and services that will meet or exceed our customers' requirements in product quality, delivery, customer service and satisfaction.

To meet this commitment, we strive to ensure a consistent, integrated, and systematic approach to management that will meet or exceed the requirements of the ISO 9001 standard for Quality Management and the ISO 14001 standard for Environmental Management.



© Copyright 2008, Festo Corporation. While every effort is made to ensure that all dimensions and specifications are correct, Festo cannot guarantee that publications are completely free of any error, in particular typing or printing errors. Accordingly, Festo cannot be held responsible for the same. For Liability and Warranty conditions, refer to our "Terms and Conditions of Sale", available from your local Festo office. All rights reserved. No part of this publication may be reproduced, distributed, or transmitted in any form or by any means, electronic, mechanical, photocopying or otherwise, without the prior written permission of Festo. All technical data subject to change according to technical update.



Printed on recycled paper at New Horizon Graphic, Inc., FSC certified as an environmentally friendly printing plant.

# Festo North America

## Festo Regional Contact Center

5300 Explorer Drive  
Mississauga, Ontario L4W 5G4  
Canada

### USA Customers:

For ordering assistance,

**Call:** 1.800.99.FESTO (1.800.993.3786)

**Fax:** 1.800.96.FESTO (1.800.963.3786)

**Email:** [customer.service@us.festo.com](mailto:customer.service@us.festo.com)

For technical support,

**Call:** 1.866.GO.FESTO (1.866.463.3786)

**Fax:** 1.800.96.FESTO (1.800.963.3786)

**Email:** [product.support@us.festo.com](mailto:product.support@us.festo.com)

### Canadian Customers:

**Call:** 1.877.GO.FESTO (1.877.463.3786)

**Fax:** 1.877.FX.FESTO (1.877.393.3786)

**Email:** [festo.canada@ca.festo.com](mailto:festo.canada@ca.festo.com)

---

## USA Headquarters

Festo Corporation  
395 Moreland Road  
P.O. Box 18023  
Hauppauge, NY 11788, USA  
[www.festo.com/us](http://www.festo.com/us)

---

## USA Sales Offices

### Appleton

North 922 Tower View Drive, Suite N  
Greenville, WI 54942, USA

### Boston

120 Presidential Way, Suite 330  
Woburn, MA 01801, USA

### Chicago

1441 East Business Center Drive  
Mt. Prospect, IL 60056, USA

### Dallas

1825 Lakeway Drive, Suite 600  
Lewisville, TX 75057, USA

### Detroit – Automotive Engineering Center

2601 Cambridge Court, Suite 320  
Auburn Hills, MI 48326, USA

### New York

395 Moreland Road  
Hauppauge, NY 11788, USA

### Silicon Valley

4935 Southfront Road, Suite F  
Livermore, CA 94550, USA

## United States



**USA Headquarters, East:** Festo Corp., 395 Moreland Road, Hauppauge, NY 11788

Phone: 1.631.435.0800; Fax: 1.631.435.8026;

Email: [info@festo-usa.com](mailto:info@festo-usa.com)

[www.festo.com/us](http://www.festo.com/us)

## Canada



**Headquarters:** Festo Inc., 5300 Explorer Drive, Mississauga, Ontario L4W 5G4

Phone: 1.905.624.9000; Fax: 1.905.624.9001;

Email: [festo.canada@ca.festo.com](mailto:festo.canada@ca.festo.com)

[www.festo.ca](http://www.festo.ca)

## Mexico



**Headquarters:** Festo Pneumatic, S.A., Av. Ceylán 3, Col. Tequesquahuac,  
54020 Tlalneantla, Edo. de México

Phone: 011 52 [55] 53 21 66 00; Fax: 011 52 [55] 53 21 66 65;

Email: [festo.mexico@mx.festo.com](mailto:festo.mexico@mx.festo.com)

[www.festo.com/mx](http://www.festo.com/mx)

---

## Central USA

Festo Corporation  
1441 East Business  
Center Drive  
Mt. Prospect, IL 60056, USA  
Phone: 1.847.759.2600  
Fax: 1.847.768.9480



## Western USA

Festo Corporation  
4935 Southfront Road,  
Suite F  
Livermore, CA 94550, USA  
Phone: 1.925.371.1099  
Fax: 1.925.245.1286



---

## Festo Worldwide

Argentina Australia Austria Belarus Belgium Brazil Bulgaria Canada Chile China Colombia Croatia Czech Republic Denmark  
Estonia Finland France Germany Great Britain Greece Hong Kong Hungary India Indonesia Iran Ireland Israel Italy Japan Latvia  
Lithuania Malaysia Mexico Netherlands New Zealand Norway Peru Philippines Poland Romania Russia Serbia Singapore  
Slovakia Slovenia South Africa South Korea Spain Sweden Switzerland Taiwan Thailand Turkey Ukraine United States Venezuela

[www.festo.com](http://www.festo.com)