

Standard cylinders DNG/DNGZK/DNGZS, ISO 15552



# Standard cylinders DNG/DNGZK/DNGZS, ISO 15552

FESTO

Features

## Brief description

- Double-acting
- For contactless position sensing
- With adjustable end-position cushioning at both ends
- Robust tie rod design
- Standards-based cylinders to ISO 15552 (corresponds to the withdrawn standards ISO 6431, DIN ISO 6431, VDMA 24 562, NF E 49 003.1 and UNI 10290)



DIN



DNG

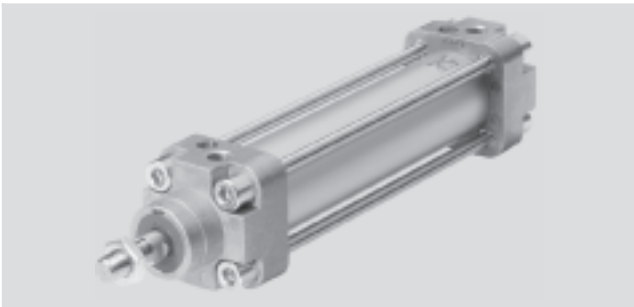

DNGZK with central trunnion mounting (adjustable)

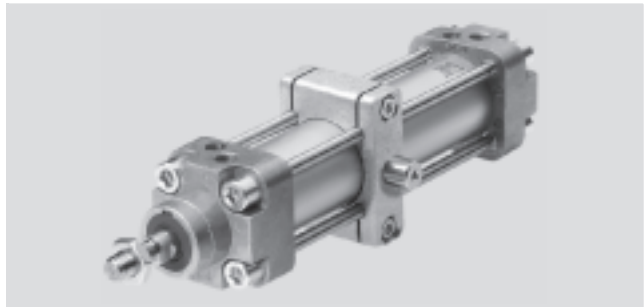

DNGZS with central trunnion mounting (fixed)

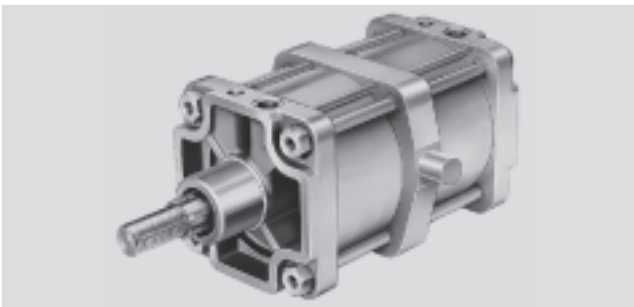

# Standard cylinders DNG/DNGZK/DNGZS, ISO 15552

Features

## Mounting options

### Installation of basic version

Mounting at front

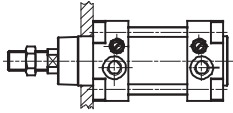

Mounting at rear

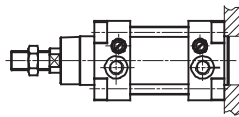

### Installation options using mounting attachments

Foot mounting MS1<sup>1)</sup>

HNG

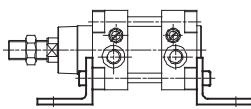

Flange mounting MF1/MF2<sup>1)</sup>

FNG

at front      at rear

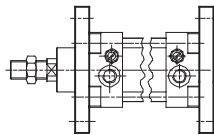

Swivel flange MP2<sup>1)</sup>

SNG/SNGB/SNGL

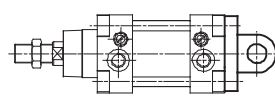

1) Standard designation to ISO 15552 (ISO 6431)

# Standard cylinders DNG/DNGZK/DNGZS, ISO 15552

Product range overview

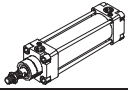
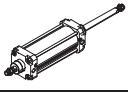
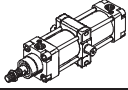
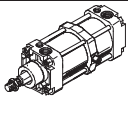
Function	Design	Type	Piston Ø [mm]	Variable stroke <sup>1)</sup> [mm]	Position sensing A	Cushioning Adjustable PPV
Double-acting	<b>Basic version</b>					
		<b>DNG</b> Single-ended piston rod	160, 200, 250, 320	1 ... 2000	■	■
		<b>DNG-...-S2</b> Through piston rod	160, 200, 250, 320	1 ... 2000	■	■
	<b>With central trunnion mounting</b>					
		<b>DNGZK</b> adjustable	160, 200	1 ... 2000	■	■
	<b>DNGZS</b> fixed	250, 320	1 ... 1100	■	■	

1) Cylinders with position sensing require a minimum stroke of 10 mm to ensure reliable sensing

# Standard cylinders DNG/DNGZK/DNGZS, ISO 15552

Product range overview

Type	Piston rod		Heat-resistant seal S6	High corrosion protection S8	➔ Page/Internet
	Male thread	Stainless steel S3			
<b>Basic version</b>					
<b>DNG</b> Single-ended piston rod	■	■	■	■	9
<b>DNG-...-S2</b> Through piston rod	■	-	-	-	9
<b>With central trunnion mounting</b>					
<b>DNGZK</b> adjustable	■	■	■	■	9
<b>DNGZS</b> fixed	■	■	■	■	9

# Standard cylinders DNG/DNGZK/DNGZS, ISO 15552

Peripherals overview

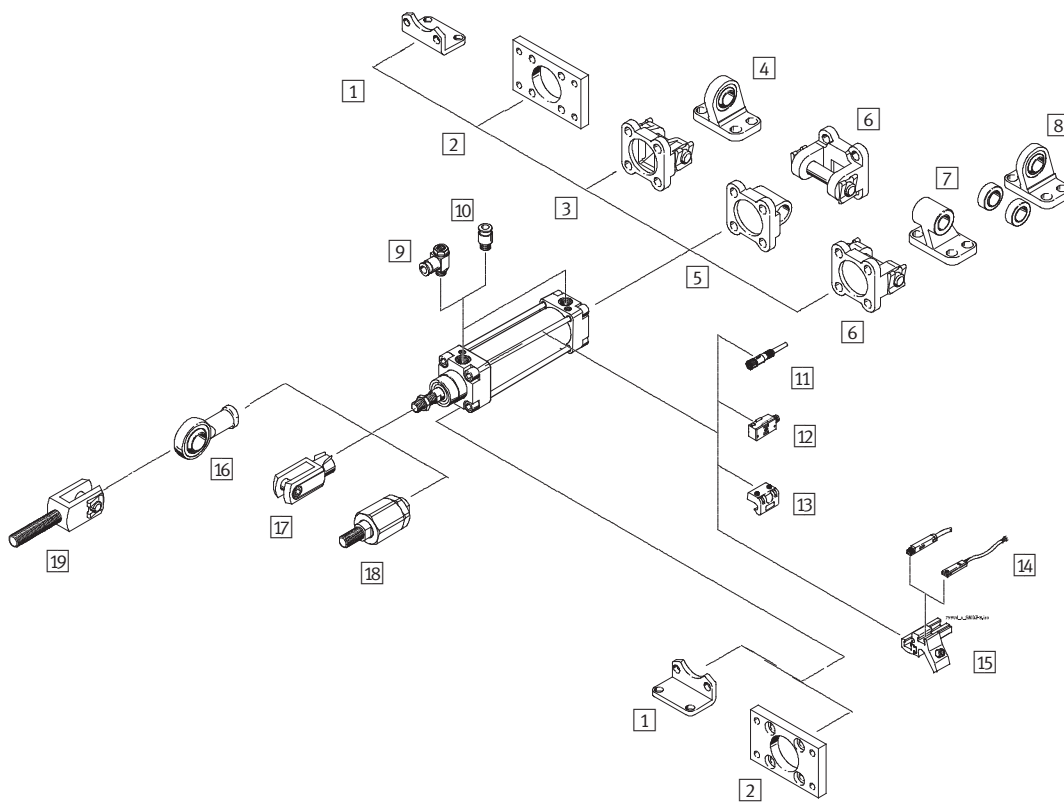

Mounting attachments and accessories		
	Brief description	➔ Page/Internet
1	Foot mounting HNG For bearing and end caps corresponds to MS1 to ISO 15552	17
2	Flange mounting FNG For bearing or end caps corresponds to MF1/MF2 to ISO 15552	18
3	Swivel flange SNG For end caps	18
4	Clevis foot mounting LSNG With spherical bearing	20
5	Swivel flange SNGL For end caps corresponds to MP2 to ISO 15552	19

## Standard cylinders DNG/DNGZK/DNGZS, ISO 15552

Peripherals overview

Mounting attachments and accessories			
	Brief description	→ Page/Internet	
6	Swivel flange SNGB	For end caps corresponds to MP2 to ISO 15552	19
7	Clevis foot mounting LNG	For swivel flange SNGB	20
8	Clevis foot mounting LSN	With spherical bearing	20
9	One-way flow control valve GRLA	For speed regulation	grla
10	Push-in fitting QS	For connecting compressed air tubing with standard O.D.	quick star
11	Connecting cable, straight NEBU	–	21
	Connecting cable, angled NEBU	–	21
12	Proximity sensors SMEO-1/SMT0-1	–	22
13	Sensor mounting kit SMB-1	For proximity sensor SMEO-1/SMT0-1	22
14	Proximity sensors SME/SMT-8	–	21
15	Sensor mounting kit SMBZ-8- ...	For proximity sensor SME/SMT-8	21
16	Rod eye SGS	With spherical bearing	20
17	Rod clevis SG	Permits a swivelling movement of the cylinder in one plane	20
18	Self-aligning rod coupler FK	For compensating radial and angular deviations	20
19	Rod clevis SGA	Suitable for spherical mounting of cylinders in conjunction with rod eye SGS	20

# Standard cylinders DNG/DNGZK/DNGZS, ISO 15552

Type codes

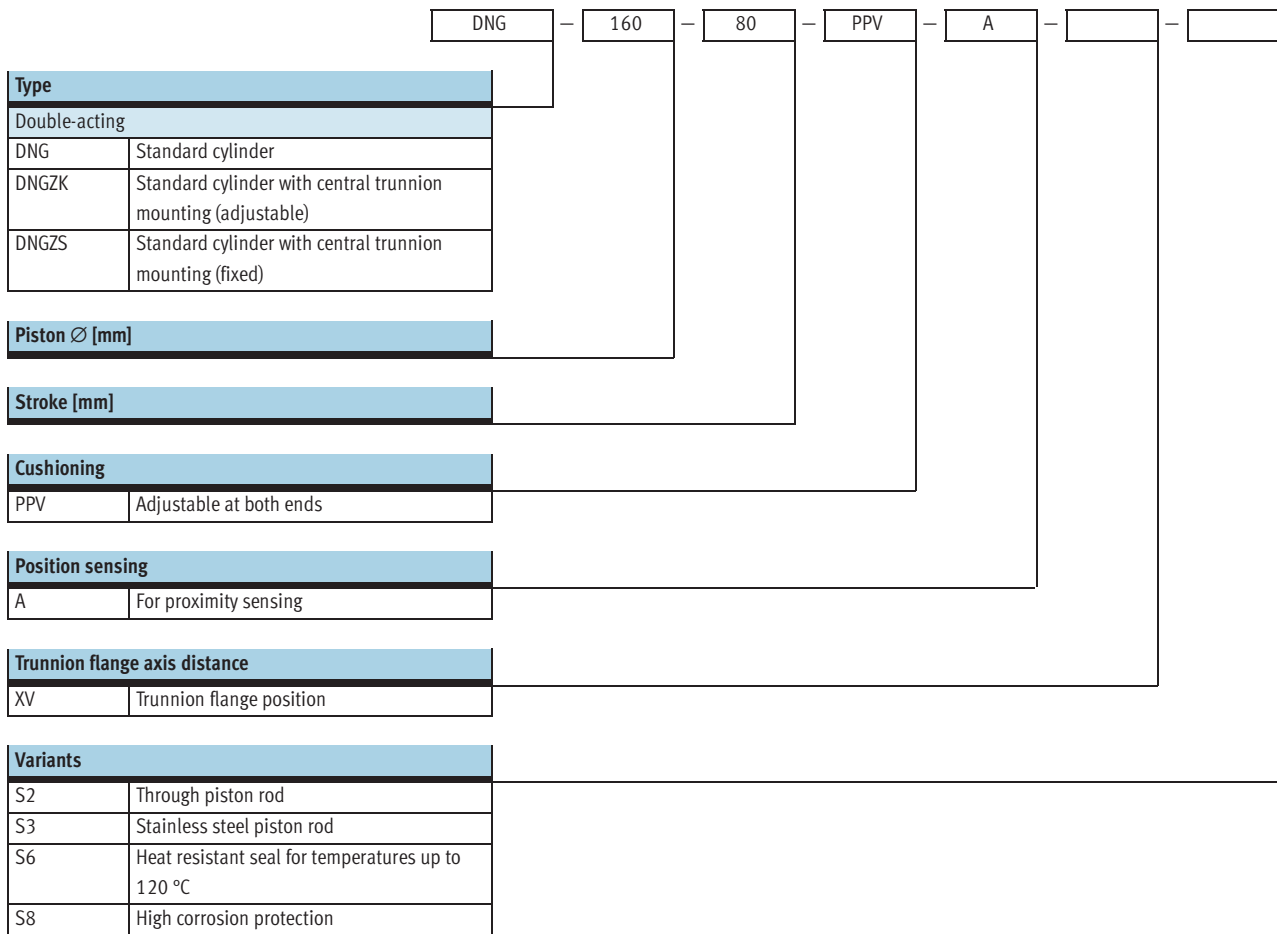



# Standard cylinders DNG/DNGZK/DNGZS, ISO 15552

Technical data

Function

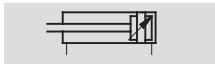

- N- Diameter  
160 ... 320 mm
- T- Stroke length  
10 ... 2000 mm

www.festo.com/en/  
Spare\_parts\_service

Variants



S2



S3



S6



S8

- Standards-based cylinders to ISO 15552 (corresponds to the withdrawn standards ISO 6431, DIN ISO 6431, VDMA 24 562, NF E 49 003.1 and UNI 10290)



DIN



DNG

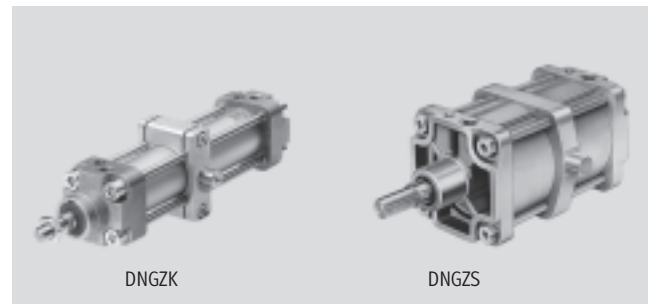

DNGZK

DNGZS

General technical data				
Piston Ø	160	200	250	320
Pneumatic connection	G3/4	G3/4	G1	G1
Piston rod thread	M36x2	M36x2	M42x2	M48x2
Operating medium	Compressed air in accordance with ISO 8573-1:2010 [7:4:4]			
Note on operating/pilot medium	Operation with lubricated medium possible (in which case lubricated operation will always be required)			
Design	Piston			
	Piston rod			
	Profile barrel			
Cushioning	Adjustable at both ends			
Cushioning length [mm]	40	50	60	66
Position sensing	For proximity sensing			
Type of mounting	Via accessories			
Mounting position	Any			

Operating and environmental conditions	
Operating pressure [bar]	0.6 ... 10
Ambient temperature <sup>1)</sup> [°C]	-20 ... +80
ATEX	Specified types → www.festo.com

1) Note operating range of proximity sensors

Forces [N]				
Piston Ø	160	200	250	320
Theoretical force at 6 bar, advancing	12,064	18,850	29,450	48,250
Theoretical force at 6 bar, retracting	11,310	18,096	28,270	46,380

# Standard cylinders DNG/DNGZK/DNGZS, ISO 15552

Technical data

## Lateral force $F_Q$ as a function of the stroke length $l$

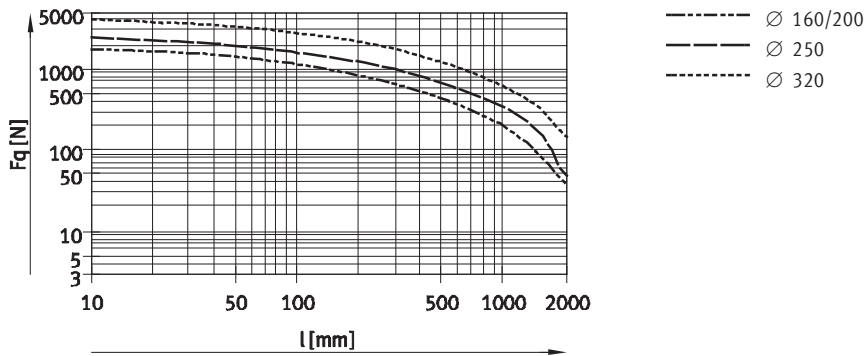
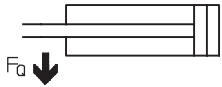

Weights [g]				
Piston Ø	160	200	250	320
<b>DNG</b>				
Product weight at 0 mm stroke	17,265	20,115	30,800	53,200
Additional weight per 10 mm stroke	190	250	360	570
<b>DNGZK</b>				
Product weight at 0 mm stroke	19,510			
Additional weight per 10 mm stroke	190			

# Standard cylinders DNG/DNGZK/DNGZS, ISO 15552

Technical data

## Materials

### Sectional view DNG

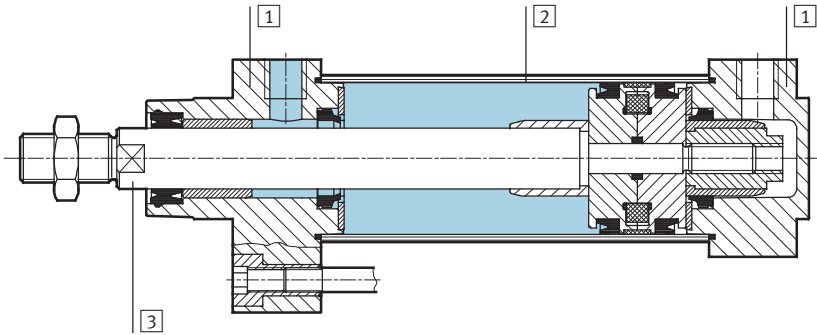

### Sectional view DNGZK

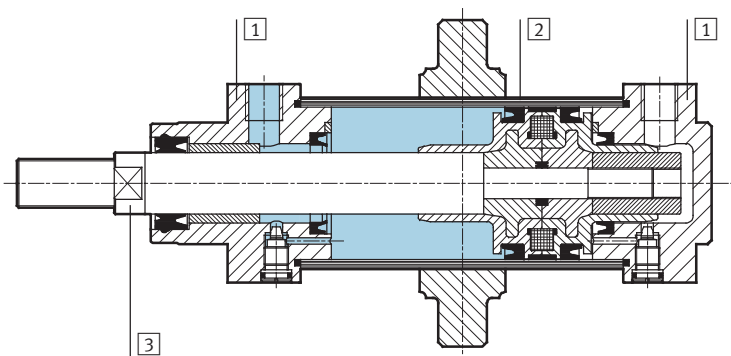

Standard cylinder	DNG	DNGZK
Piston Ø	160 ... 200	250 ... 320
1 Bearing and end caps	Aluminium	Die-cast aluminium
2 Cylinder barrel	Aluminium	High-alloy steel
3 Piston rod, tie rod	High-alloy steel	Brass
- Seals	NBR, TPE-U (PU)	

# Standard cylinders DNG/DNGZK/DNGZS, ISO 15552

Technical data

FESTO

## Dimensions

Download CAD Data → [www.festo.com/us/cad](http://www.festo.com/us/cad)

### DNG

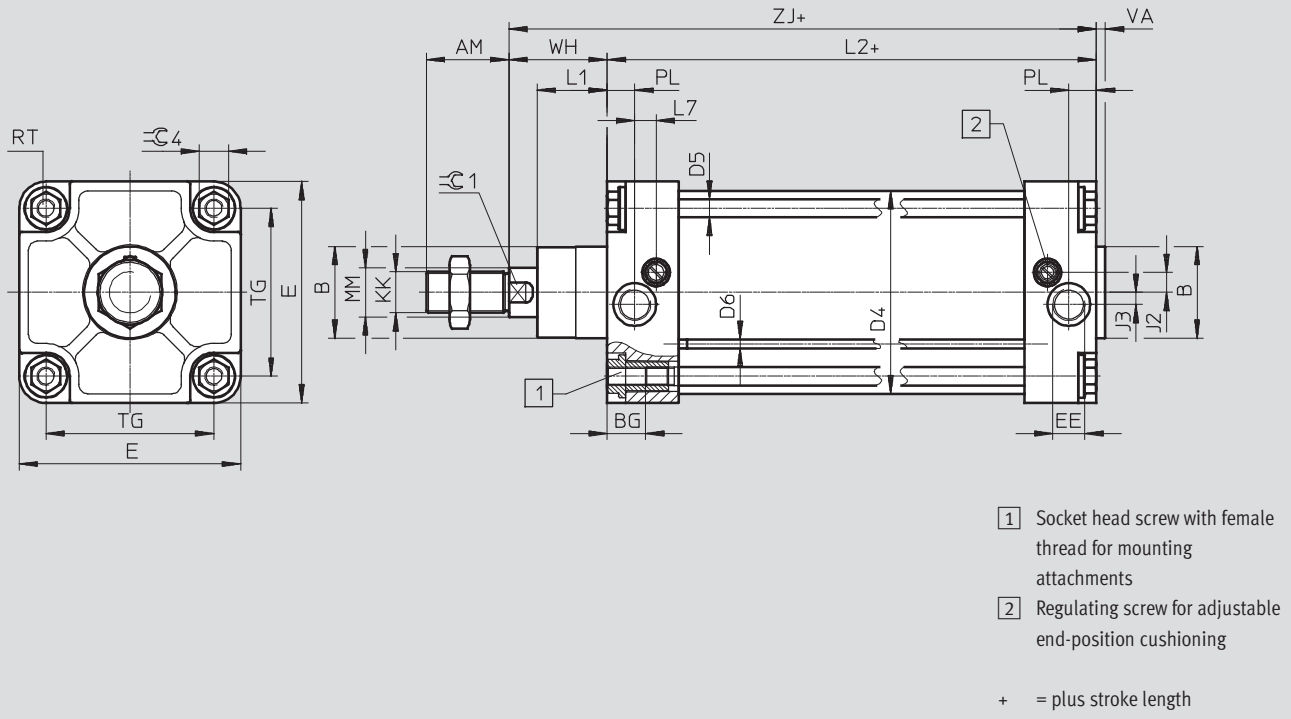

### Variant S2 – Through piston rod

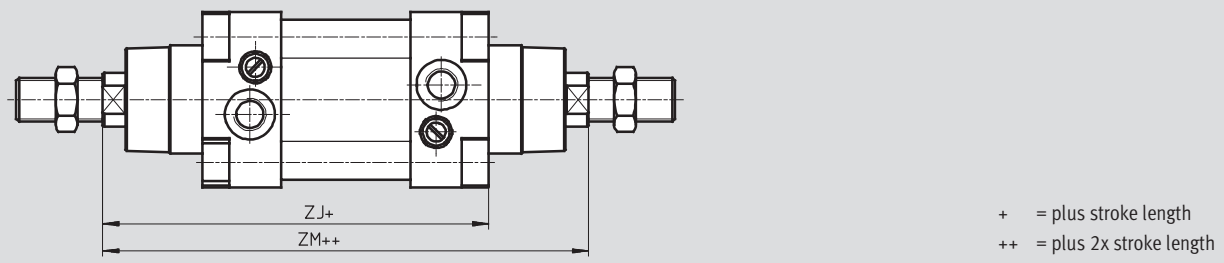

### DNGZK/DNGZS – with central trunnion mounting adjustable, fixed

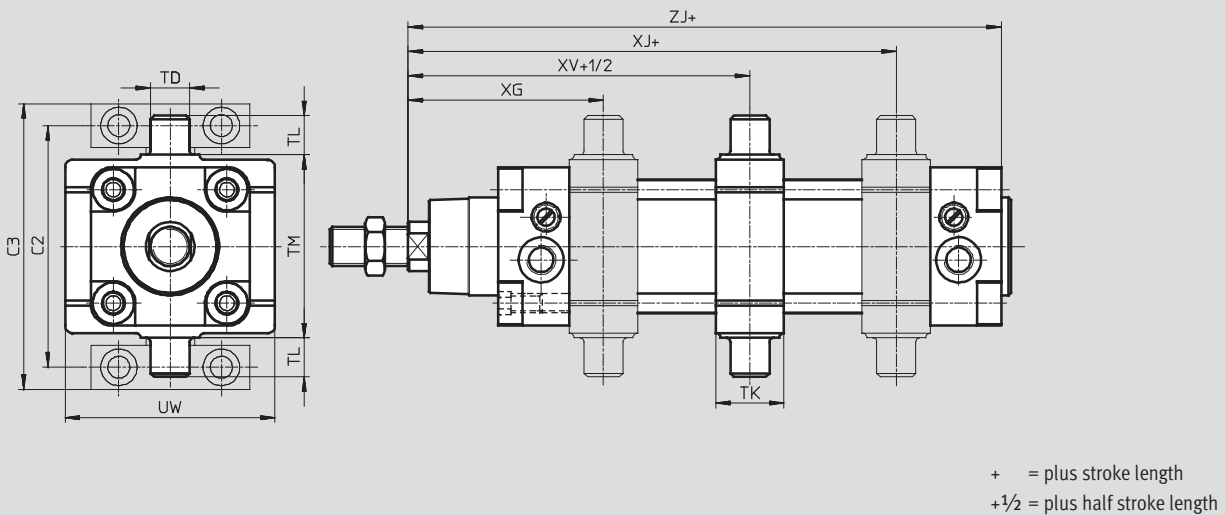

# Standard cylinders DNG/DNGZK/DNGZS, ISO 15552

Technical data

∅ [mm]	AM	B ∅ d11	BG	C2	C3	D4 ∅	D5 ∅	E	EE	J2	J3
160	72	65	24	245	280	167	16	186	G $\frac{3}{4}$	16	22
200	72	75	24	295	330	210	16	230	G $\frac{3}{4}$	22	22
250	84	90	25.5	375	420	254	18.3	270	G1	25	25
320	96	110	28.5	465	520	325	22	340	G1	30	30

∅ [mm]	KK	L1	L2	L7	MM ∅	PL	RT	TD ∅ e9	TG	TK	TL
160	M36x2	55	180 ±1.1	8.5	40	25.5	M16	32	140	48	32
200	M36x2	65	180 ±1.6	–	40	23	M16	32	175	48	32
250	M42x2	67	200 ±2	–	50	31	M20	40	220	60	40
320	M48x2	82	220 ±2	–	63	31	M24	50	270	70	50

∅ [mm]	TM	UW	VA	WH	XG	XJ	XV	ZJ	ZM	≙C1	≙C4
160	200	200	6	80	155 ±2.6	185 ±2.6	170 ±2.6	260	340	36	32
200	250	240	6	95	165 ±2.2	205 ±2.2	185 ±2.2	275	370	36	32
250	320	270	10	105	187	223	205	305	410	46	36
320	400	340	10	120	211	249	230	340	460	55	46

## Note

DNGZS-250/-320-...-PPV-A:  
The central trunnion mounting is fitted as standard tightly screwed with the tie rods in the cylinder mid-section. As a special design,

mounting is possible between the dimensions XG and XJ.  
The required dimension XV must be entered in the order (➔ 16).

# Standard cylinders DNG/DNGZK/DNGZS, ISO 15552



Technical data

Ordering data					
Design	Stroke [mm]	Piston Ø 160 [mm]		Piston Ø 200 [mm]	
		Part No.	Type <sup>1)</sup>	Part No.	Type <sup>1)</sup>
<b>Basic version</b>					
Variable stroke	1 ... 2,000 <sup>2)</sup>	<b>33024</b>	<b>DNG-160-...-PPV-A</b>	<b>33025</b>	<b>DNG-200-...-PPV-A</b>
	1 ... 1,100 <sup>2)</sup>	–	–	–	–
Variant S2	1 ... 2,000 <sup>2)</sup>	<b>34632</b>	<b>DNG-160-...-PPV-A-S2</b>	<b>34633</b>	<b>DNG-200-...-PPV-A-S2</b>
	1 ... 1,100 <sup>2)</sup>	–	–	–	–
Variant S3	1 ... 2,000 <sup>2)</sup>	<b>34980</b>	<b>DNG-160-...-PPV-A-S3</b>	<b>34981</b>	<b>DNG-200-...-PPV-A-S3</b>
	1 ... 1,100 <sup>2)</sup>	–	–	–	–
Variant S6	1 ... 2,000 <sup>2)</sup>	<b>34861</b>	<b>DNG-160-...-PPV-A-S6</b>	<b>34862</b>	<b>DNG-200-...-PPV-A-S6</b>
	1 ... 1,100 <sup>2)</sup>	–	–	–	–
Variant S8	1 ... 2,000 <sup>2)</sup>	<b>35497</b>	<b>DNG-160-...-PPV-A-S8</b>	<b>35498</b>	<b>DNG-200-...-PPV-A-S8</b>
	1 ... 1,100 <sup>2)</sup>	–	–	–	–
<b>with adjustable central trunnion mounting</b>					
Variable stroke	1 ... 2,000 <sup>2)</sup>	<b>34447</b>	<b>DNGZK-160-...-PPV-A</b>	<b>34456</b>	<b>DNGZK-200-...-PPV-A</b>
Variant S3	1 ... 2,000 <sup>2)</sup>	<b>34945</b>	<b>DNGZK-160-...-PPV-A-S3</b>	<b>34946</b>	<b>DNGZK-200-...-PPV-A-S3</b>
Variant S6	1 ... 2,000 <sup>2)</sup>	<b>34954</b>	<b>DNGZK-160-...-PPV-A-S6</b>	<b>34955</b>	<b>DNGZK-200-...-PPV-A-S6</b>
Variant S8	1 ... 2,000 <sup>2)</sup>	<b>35526</b>	<b>DNGZK-160-...-PPV-A-S8</b>	<b>35527</b>	<b>DNGZK-200-...-PPV-A-S8</b>

1) The scope of delivery includes a hex nut for the piston rod thread.

2) Cylinders with position sensing require a minimum stroke of 10 mm to ensure reliable sensing

# Standard cylinders DNG/DNGZK/DNGZS, ISO 15552

Technical data

Ordering data					
Design	Stroke [mm]	Piston Ø 250 [mm]		Piston Ø 320 [mm]	
		Part No.	Type <sup>1)</sup>	Part No.	Type <sup>1)</sup>
<b>Basic version</b>					
Variable stroke	1 ... 2,000 <sup>2)</sup>	-		-	
	1 ... 1,100 <sup>2)</sup>	<b>151892</b>	<b>DNG-250-...-PPV-A</b>	<b>151897</b>	<b>DNG-320-...-PPV-A</b>
Variant S2	1 ... 2,000 <sup>2)</sup>	-		-	
	1 ... 1,100 <sup>2)</sup>	<b>151893</b>	<b>DNG-250-...-PPV-A-S2</b>	<b>151898</b>	<b>DNG-320-...-PPV-A-S2</b>
Variant S3	1 ... 2,000 <sup>2)</sup>	-		-	
	1 ... 1,100 <sup>2)</sup>	<b>151894</b>	<b>DNG-250-...-PPV-A-S3</b>	<b>151899</b>	<b>DNG-320-...-PPV-A-S3</b>
Variant S6	1 ... 2,000 <sup>2)</sup>	-		-	
	1 ... 1,100 <sup>2)</sup>	<b>151895</b>	<b>DNG-250-...-PPV-A-S6</b>	<b>151900</b>	<b>DNG-320-...-PPV-A-S6</b>
Variant S8	1 ... 2,000 <sup>2)</sup>	-		-	
	1 ... 1,100 <sup>2)</sup>	<b>151896</b>	<b>DNG-250-...-PPV-A-S8</b>	<b>151901</b>	<b>DNG-320-...-PPV-A-S8</b>
<b>with fixed central trunnion mounting</b>					
Variable stroke	1 ... 1,100 <sup>2)</sup>	➔ 16			

1) The scope of delivery includes a hex nut for the piston rod thread.

2) Cylinders with position sensing require a minimum stroke of 10 mm to ensure reliable sensing

# Standard cylinders DNG/DNGZK/DNGZS, to ISO 15552



Ordering data – Modular product DNGZS

M Mandatory data						O Options		
Module No.	Function	Piston Ø	Stroke	Cushioning	Position sensing	Trunnion flange position	Temperature-resistant	Corrosion protection
157500 157504	DNGZS	250 320	10 ... 1 100	PPV	A	...XV	S6	S3 S8
<b>Ordering example</b>								
<b>157504</b>	<b>DNGZS</b>	<b>- 320</b>	<b>- 600</b>	<b>- PPV</b>	<b>- A</b>	<b>- 215XV</b>	<b>- S6</b>	<b>- S3</b>

Ordering table						
Size	250	320	Condition s	Code	Enter code	
M Module No.	<b>157500</b>	<b>157504</b>				
Function	Standard cylinder, double-acting, with central trunnion mounting to ISO 15552			<b>DNGZS</b>	DNGZS	
Piston Ø [mm]	250	320		-...		
Stroke [mm]	10 ... 1 100			-...		
Cushioning	Pneumatic cushioning adjustable at both ends			<b>-PPV</b>	-PPV	
Position sensing	For proximity sensing			<b>-A</b>	-A	
O Trunnion flange position [mm]	187 ... 1 323	211 ... 1 349	[1]	<b>-...XV</b>		
Temperature-resistant	Heat-resistant seals up to max. 120 °C			<b>-S6</b>		
Corrosion protection	Stainless steel piston rod			<b>- S3</b>		
	High corrosion protection including piston rod, stainless steel			[2]	<b>-S8</b>	

[1] ...XV Trunnion flange at standard mid-position of cylinder:  
 Piston Ø 250 mm:  $205 \text{ mm} + \frac{\text{Stroke}}{2}$   
 Piston Ø 320 mm:  $230 \text{ mm} + \frac{\text{Stroke}}{2}$

[2] S8 Not with S6.

Transfer order code

	<b>DNGZS</b>	-		-		-	<b>PPV</b>	-	<b>A</b>	-		-		-	
--	--------------	---	--	---	--	---	------------	---	----------	---	--	---	--	---	--



# Standard cylinders DNG/DNGZK/DNGZS, ISO 15552

Accessories

## Foot mounting HNG

Material:  
Galvanised steel  
Free of copper and PTFE

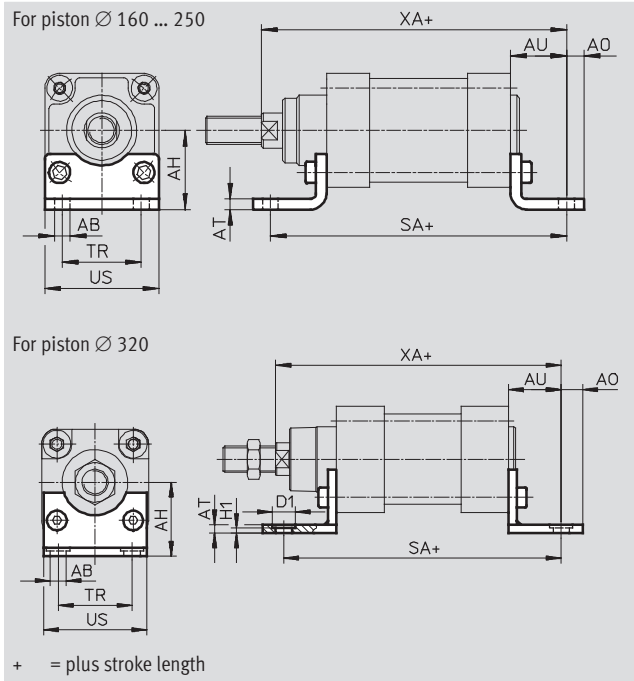

Dimensions and ordering data																
For $\varnothing$ [mm]	AB $\varnothing$ H14	AH	AO	AT	AU	D1	H1	SA	TR	US	XA	CRC <sup>1)</sup>	Weight [g]	Part No.	Type	
160	18.5	115	20	10	60	-	-	300	115	169	320	2	2,200	<b>34476</b>	<b>HNG-160</b>	
200	24	135	30	12	70	-	-	320	135	214	345	2	3,795	<b>34477</b>	<b>HNG-200</b>	
250	28	165	35	20	75	-	-	350	165	270	380	2	8,000	<b>157510</b>	<b>HNG-250</b>	
320	35	200	40	25	85	60	23	390	200	340	425	2	13,000	<b>157511</b>	<b>HNG-320</b>	

1) Corrosion resistance class 2 according to Festo standard 940 070  
Components requiring moderate corrosion resistance. Externally visible parts with primarily decorative surface requirements which are in direct contact with a surrounding industrial atmosphere or media such as cooling or lubricating agents

# Standard cylinders DNG/DNGZK/DNGZS, ISO 15552



Accessories

## Flange mounting FNG

Material:  
Painted nodular graphite cast iron  
Free of copper and PTFE

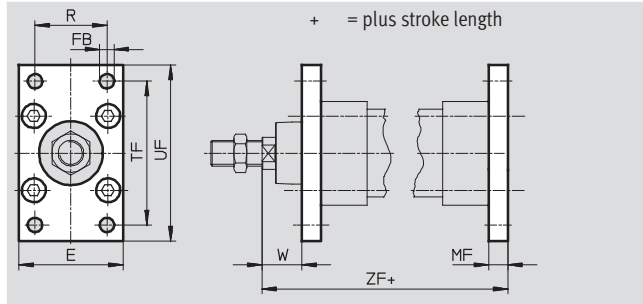
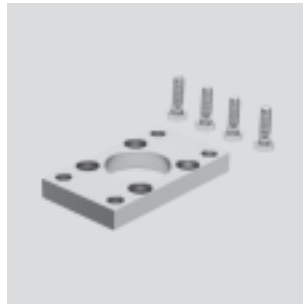

Dimensions and ordering data												
For Ø	E	FB	MF	R	TF	UF	W	ZF	CRC <sup>1)</sup>	Weight	Part No.	Type
[mm]		Ø								[g]		
160	180	18	20	115	230	280	60	280	1	3,550	<b>34478</b>	<b>FNG-160</b>
200	220	22	25	135	270	320	70	300	1	5,321	<b>34479</b>	<b>FNG-200</b>
250	270	26	25	165	330	390	80	330	1	8,657	<b>157508</b>	<b>FNG-250</b>
320	340	33	30	200	400	470	90	370	1	15,109	<b>157509</b>	<b>FNG-320</b>

1) Corrosion resistance class 1 according to Festo standard 940 070  
Components with light corrosion exposure. Protection for transport and storage. Components without significant decorative function or surface, e.g. installed out of sight internally or behind covers.

## Swivel flange SNG

for clevis foot LSNG

Material:  
Die-cast aluminium

RoHS-compliant  
Free of copper and PTFE

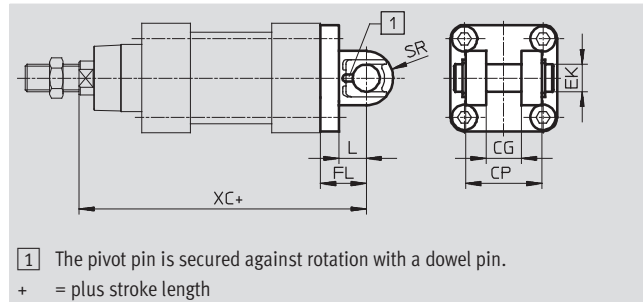

Dimensions and ordering data												
For Ø	CG	CP	EK	FL	L	SR	XC	CRC <sup>1)</sup>	Weight	Part No.	Type	
[mm]	H14	d12	Ø						[g]			
160	43	122	35	55	35	32	315	2	3,285	<b>152597</b>	<b>SNG-160</b>	
200	43	122	35	60	35	32	335	2	4,600	<b>152598</b>	<b>SNG-200</b>	

1) Corrosion resistance class 2 according to Festo standard 940 070  
Components requiring moderate corrosion resistance. Externally visible parts with primarily decorative surface requirements which are in direct contact with a surrounding industrial atmosphere or media such as cooling or lubricating agents

# Standard cylinders DNG/DNGZK/DNGZS, ISO 15552

Accessories

## Swivel flange SNGB for clevis foot LN/LSN

Material:  
Die-cast aluminium  
Ø 200: Steel

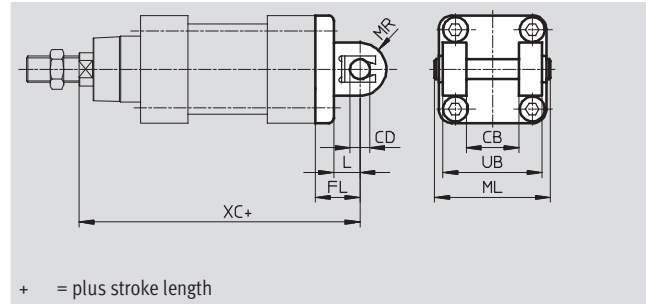

Dimensions and ordering data												
For Ø	CB	CD	FL	L	ML	MR	UB	XC	CRC <sup>1)</sup>	Weight	Part No.	Type
[mm]	Ø	Ø					h14			[g]		
160	90	30	55	37	191	30	170	315	2	7,000	34547	SNGB-160
200	90	30	60	35	191	36	170	335	2	11 000	562455	SNGB-200-B
250	110	40	70	47	231	40	200	375	2	15 200	157512	SNGB-250
320	120	45	80	52	253	45	220	420	2	26 450	157513	SNGB-320

1) Corrosion resistance class 2 according to Festo standard 940 070  
Components requiring moderate corrosion resistance. Externally visible parts with primarily decorative surface requirements which are in direct contact with a surrounding industrial atmosphere or media such as cooling or lubricating agents

## Swivel flange SNGL

Material:  
Die-cast aluminium

Variant CT:  
Free of copper and PTFE

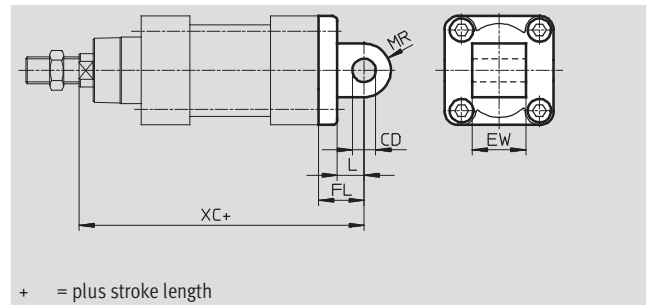



Dimensions and ordering data											
For Ø	CD	EW	FL	L	MR	XC	CRC <sup>1)</sup>	Weight	Part No.	Type	
[mm]	Ø							[g]			
160	30	90	55	35	25	315	2	2,252	151534	SNGL-160	
200	30	90	60	35	25	335	2	3,306	151535	SNGL-200	





1) Corrosion resistance class 2 according to Festo standard 940 070  
Components requiring moderate corrosion resistance. Externally visible parts with primarily decorative surface requirements which are in direct contact with a surrounding industrial atmosphere or media such as cooling or lubricating agents

# Standard cylinders DNG/DNGZK/DNGZS, ISO 15552

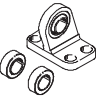
FESTO

Accessories



Ordering data – Mounting attachments				Technical data → Internet: clevis foot			
Designation	For Ø	Part No.	Type	Designation	For Ø	Part No.	Type
<b>Clevis foot LSNG</b>				<b>Clevis foot LNG</b>			
	160	152599	LSNG-160		160	–	
	200	152600	LSNG-200		200	33898	LNG-200
<b>Clevis foot LSN</b>							
	160	6988	LSN-160				
	200	6989	LSN-200				
	250	6990	LSN-250				
	320	6991	LSN-320				

Ordering data – Piston rod attachments				Technical data → Internet: piston-rod attachment			
Designation	For Ø	Part No.	Type	Designation	For Ø	Part No.	Type
<b>Rod eye SGS</b>				<b>Rod clevis SGA</b>			
	160	10775	SGS-M36x2		160	10775	SGA-M36x2
	200				200		
	250	10776	SGS-M42x2		–	–	
	320	10777	SGS-M48x2		–	–	
<b>Rod clevis SG</b>				<b>Self-aligning rod coupler FK</b>			
	160	9581	SG-M36x2		160	10746	FK-M36x2
	200				200		
	250	9582	SG-M42x2		250	–	
	320	9583	SG-M48x2		320	–	



# Standard cylinders DNG/DNGZK/DNGZS, ISO 15552

FESTO

Accessories

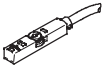
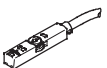
Ordering data – Connecting cables				Technical data → Internet: nebu	
	Electrical connection, left	Electrical connection, right	Cable length [m]	Part No.	Type
	Straight socket, M8x1, 3-pin	Cable, open end, 3-wire	2.5	541333	NEBU-M8G3-K-2.5-LE3
			5	541334	NEBU-M8G3-K-5-LE3
	Angled socket, M8x1, 3-pin	Cable, open end, 3-wire	2.5	541338	NEBU-M8W3-K-2.5-LE3
			5	541341	NEBU-M8W3-K-5-LE3

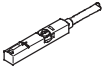
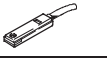
Ordering data – Proximity sensors for T-slot, magneto-resistive				Technical data → Internet: smt	
	Type of mounting	Switch output	Electrical connection	Cable length [m]	Part No. Type
N/O contact					
	Insertable in the slot from above, flush with cylinder profile, short design	PNP	Cable, 3-wire	2.5	574335 SMT-8M-A-PS-24V-E-2,5-OE
			Plug M8x1, 3-pin	0.3	574334 SMT-8M-A-PS-24V-E-0,3-M8D
			Plug M12x1, 3-pin	0.3	574337 SMT-8M-A-PS-24V-E-0,3-M12
		NPN	Cable, 3-wire	2.5	574338 SMT-8M-A-NS-24V-E-2,5-OE
			Plug M8x1, 3-pin	0.3	574339 SMT-8M-A-NS-24V-E-0,3-M8D
N/C contact					
	Insertable in the slot from above, flush with cylinder profile, short design	PNP	Cable, 3-wire	7.5	574340 SMT-8M-A-PO-24V-E-7,5-OE

Ordering data – Proximity sensors for T-slot, magnetic reed				Technical data → Internet: sme	
	Type of mounting	Switch output	Electrical connection	Cable length [m]	Part No. Type
N/O contact					
	Insertable in the slot from above, flush with cylinder profile	Contacting	Cable, 3-wire	2.5	543862 SME-8M-DS-24V-K-2,5-OE
				5.0	543863 SME-8M-DS-24V-K-5,0-OE
			Cable, 2-wire	2.5	543872 SME-8M-ZS-24V-K-2,5-OE
			Plug M8x1, 3-pin	0.3	543861 SME-8M-DS-24V-K-0,3-M8D
	Insertable in the slot lengthwise, flush with the cylinder profile	Contacting	Cable, 3-wire	2.5	150855 SME-8-K-LED-24
			Plug M8x1, 3-pin	0.3	150857 SME-8-S-LED-24
N/C contact					
	Insertable in the slot lengthwise, flush with the cylinder profile	Contacting	Cable, 3-wire	7.5	160251 SME-8-O-K-LED-24

Ordering data – Mounting kits for proximity sensors SME/SMT-8			Technical data → Internet: smbz	
	For Ø	Materials	Part No.	Type
	160 ... 320 mm	Rail: Wrought aluminium alloy, anodised Screws: High-alloy steel Free of copper and PTFE	537808	SMBZ-8-125/320

# Standard cylinders DNG/DNGZK/DNGZS, ISO 15552

Accessories

Ordering data – Rectangular proximity sensors, magneto-resistive						Technical data → Internet: smto	
	Mounting	Switch output	Electrical connection		Cable length [m]	Part No.	Type
			Cables	M8 plug			
NO contact							
	Via accessories	PNP	3-wire	–	2.5	151683	SMTO-1-PS-K-LED-24-C
			–	3-pin	–	151685	SMTO-1-PS-S-LED-24-C
		NPN	3-wire	–	2.5	151684	SMTO-1-NS-K-LED-24-C
			–	3-pin	–	151686	SMTO-1-NS-S-LED-24-C

Ordering data – Rectangular proximity sensors, magnetic reed						Technical data → Internet: smeo	
	Mounting	Electrical connection		Cable length [m]	Part No.	Type	
		Cables	M8 plug				
NO contact							
	Via accessories	3-wire	–	2.5	30459	SMEO-1-LED-24-B	
		3-wire	–	5.0	151672	SMEO-1-LED-24-K5-B	
		–	3-pin	–	150848	SMEO-1-S-LED-24-B	

Ordering data – Mounting kits for proximity sensors SMEO/SMTO-1					Technical data → Internet: smb	
	For Ø	Mounting		Part No.	Type	
	160 ... 320 mm	Directly on the mounting or tie rod		11886	SMB-1	

# Product Range and Company Overview

## A Complete Suite of Automation Services

Our experienced engineers provide complete support at every stage of your development process, including: conceptualization, analysis, engineering, design, assembly, documentation, validation, and production.



**Custom Automation Components**  
Complete custom engineered solutions



**Custom Control Cabinets**  
Comprehensive engineering support and on-site services



**Complete Systems**  
Shipment, stocking and storage services

## The Broadest Range of Automation Components

With a comprehensive line of more than 30,000 automation components, Festo is capable of solving the most complex automation requirements.



**Electromechanical**  
Electromechanical actuators, motors, controllers & drives



**Pneumatics**  
Pneumatic linear and rotary actuators, valves, and air supply



**PLCs and I/O Devices**  
PLC's, operator interfaces, sensors and I/O devices

## Supporting Advanced Automation... As No One Else Can!

Festo is a leading global manufacturer of pneumatic and electromechanical systems, components and controls for industrial automation, with more than 12,000 employees in 56 national headquarters serving more than 180 countries. For more than 80 years, Festo has continuously elevated the state of manufacturing with innovations and optimized motion control solutions that deliver higher performing, more profitable automated manufacturing and processing equipment. Our dedication to the advancement of automation extends beyond technology to the education and development of current and future automation and robotics designers with simulation tools, teaching programs, and on-site services.

## Quality Assurance, ISO 9001 and ISO 14001 Certifications

Festo Corporation is committed to supply all Festo products and services that will meet or exceed our customers' requirements in product quality, delivery, customer service and satisfaction.

To meet this commitment, we strive to ensure a consistent, integrated, and systematic approach to management that will meet or exceed the requirements of the ISO 9001 standard for Quality Management and the ISO 14001 standard for Environmental Management.



© Copyright 2008, Festo Corporation. While every effort is made to ensure that all dimensions and specifications are correct, Festo cannot guarantee that publications are completely free of any error, in particular typing or printing errors. Accordingly, Festo cannot be held responsible for the same. For Liability and Warranty conditions, refer to our "Terms and Conditions of Sale", available from your local Festo office. All rights reserved. No part of this publication may be reproduced, distributed, or transmitted in any form or by any means, electronic, mechanical, photocopying or otherwise, without the prior written permission of Festo. All technical data subject to change according to technical update.



Printed on recycled paper at New Horizon Graphic, Inc., FSC certified as an environmentally friendly printing plant.

# Festo North America

## Festo Regional Contact Center

5300 Explorer Drive  
Mississauga, Ontario L4W 5G4  
Canada

### USA Customers:

For ordering assistance,

**Call:** 1.800.99.FESTO (1.800.993.3786)

**Fax:** 1.800.96.FESTO (1.800.963.3786)

**Email:** [customer.service@us.festo.com](mailto:customer.service@us.festo.com)

For technical support,

**Call:** 1.866.GO.FESTO (1.866.463.3786)

**Fax:** 1.800.96.FESTO (1.800.963.3786)

**Email:** [product.support@us.festo.com](mailto:product.support@us.festo.com)

### Canadian Customers:

**Call:** 1.877.GO.FESTO (1.877.463.3786)

**Fax:** 1.877.FX.FESTO (1.877.393.3786)

**Email:** [festo.canada@ca.festo.com](mailto:festo.canada@ca.festo.com)

---

## USA Headquarters

Festo Corporation  
395 Moreland Road  
P.O. Box 18023  
Hauppauge, NY 11788, USA  
[www.festo.com/us](http://www.festo.com/us)

---

## USA Sales Offices

### Appleton

North 922 Tower View Drive, Suite N  
Greenville, WI 54942, USA

### Boston

120 Presidential Way, Suite 330  
Woburn, MA 01801, USA

### Chicago

1441 East Business Center Drive  
Mt. Prospect, IL 60056, USA

### Dallas

1825 Lakeway Drive, Suite 600  
Lewisville, TX 75057, USA

### Detroit – Automotive Engineering Center

2601 Cambridge Court, Suite 320  
Auburn Hills, MI 48326, USA

### New York

395 Moreland Road  
Hauppauge, NY 11788, USA

### Silicon Valley

4935 Southfront Road, Suite F  
Livermore, CA 94550, USA

## United States



**USA Headquarters, East:** Festo Corp., 395 Moreland Road, Hauppauge, NY 11788

Phone: 1.631.435.0800; Fax: 1.631.435.8026;

Email: [info@festo-usa.com](mailto:info@festo-usa.com)

[www.festo.com/us](http://www.festo.com/us)

## Canada



**Headquarters:** Festo Inc., 5300 Explorer Drive, Mississauga, Ontario L4W 5G4

Phone: 1.905.624.9000; Fax: 1.905.624.9001;

Email: [festo.canada@ca.festo.com](mailto:festo.canada@ca.festo.com)

[www.festo.ca](http://www.festo.ca)

## Mexico



**Headquarters:** Festo Pneumatic, S.A., Av. Ceylán 3, Col. Tequesquahuac,  
54020 Tlalneantla, Edo. de México

Phone: 011 52 [55] 53 21 66 00; Fax: 011 52 [55] 53 21 66 65;

Email: [festo.mexico@mx.festo.com](mailto:festo.mexico@mx.festo.com)

[www.festo.com/mx](http://www.festo.com/mx)

---

## Central USA

Festo Corporation  
1441 East Business  
Center Drive  
Mt. Prospect, IL 60056, USA  
Phone: 1.847.759.2600  
Fax: 1.847.768.9480



## Western USA

Festo Corporation  
4935 Southfront Road,  
Suite F  
Livermore, CA 94550, USA  
Phone: 1.925.371.1099  
Fax: 1.925.245.1286



---

## Festo Worldwide

Argentina Australia Austria Belarus Belgium Brazil Bulgaria Canada Chile China Colombia Croatia Czech Republic Denmark  
Estonia Finland France Germany Great Britain Greece Hong Kong Hungary India Indonesia Iran Ireland Israel Italy Japan Latvia  
Lithuania Malaysia Mexico Netherlands New Zealand Norway Peru Philippines Poland Romania Russia Serbia Singapore  
Slovakia Slovenia South Africa South Korea Spain Sweden Switzerland Taiwan Thailand Turkey Ukraine United States Venezuela

[www.festo.com](http://www.festo.com)