

Twin-piston semi-rotary drives DRRD

FESTO



Twin-piston semi-rotary drives DRRD

Key features

At a glance

- Rack and pinion principle
- Very high accuracy in the end positions
- Very high load bearing capacity
- Very good axial run-out at the flanged shaft
- High mass moments of inertia
- Low-backlash and dynamic
- Splash-proof design to IP65 based on EN 60529
- Defined interfaces
- Supply port at one end
- Choice of mounting options
- Ideal for use in handling applications

Wide choice of variants

Flanged shaft



- Size 16 ... 63
- Torque: 1.6 ... 112 Nm
- Swivel angle: 0 ... 180°

End-position locking



- Size 16 ... 63
- Mechanical lock in the end positions to prevent unwanted movement in unpressurised condition

Position sensing



- Size 16 ... 63
- T-slot for proximity sensor SMT-/SME-8

External position sensing (sensor mounting)



- Size 16 ... 63
- Position sensing possible directly at the flanged shaft
- Inductive sensors SIES can be used in combination with external position sensing

Cushioning



- Size 16 ... 63
- Choice of four cushioning types:
 - Elastic cushioning with metal end position (P)
 - Shock absorber (Y9)
 - Shock absorber, hard (Y10)
 - Shock absorber, external (Y12)

External cushioning



- Size 16 ... 63
- The full torque can be realised in the end positions in combination with external cushioning

Energy throughfeed



- Size 16 ... 63
- Electric signals or compressed air can be transferred through the hollow shaft using the energy throughfeed. This enables fast and easy supply of the parts connected to the flange (e.g. gripper).

Mounting options

Via through-holes

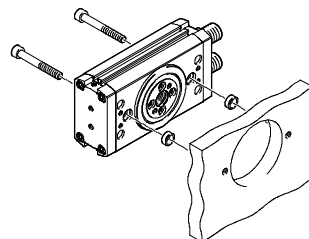
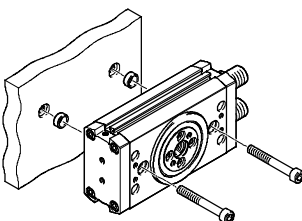

Via thread in the housing profile

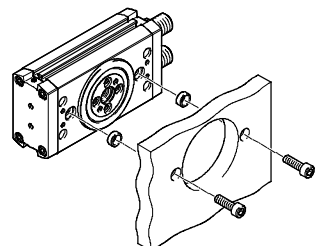
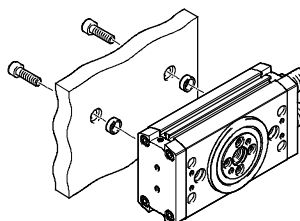

Twin-piston semi-rotary drives DRRD

System example

System product for handling and assembly technology

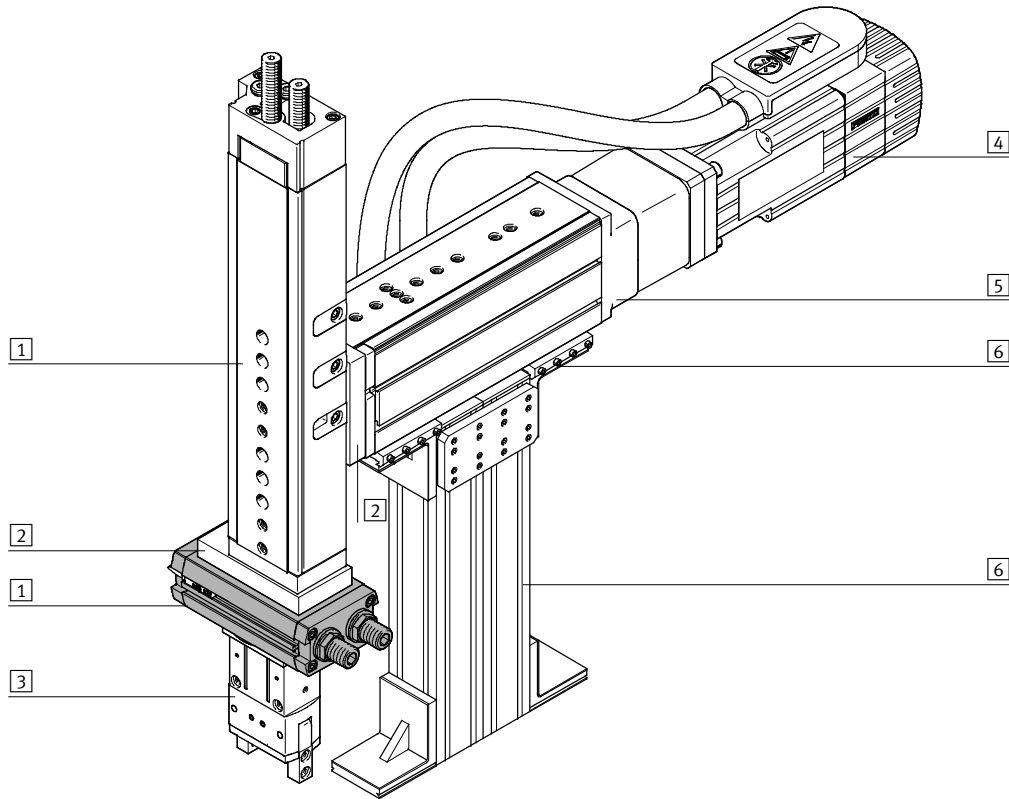

System components and accessories		
	Brief description	→ Page/Internet
1	Drives	drive
2	Adapters	adapter kit
3	Grippers	gripper
4	Motors	motor
5	Axes	axis
6	Basic components	basic component
-	Installation components	installation component

Twin-piston semi-rotary drives DRRD

Peripherals overview

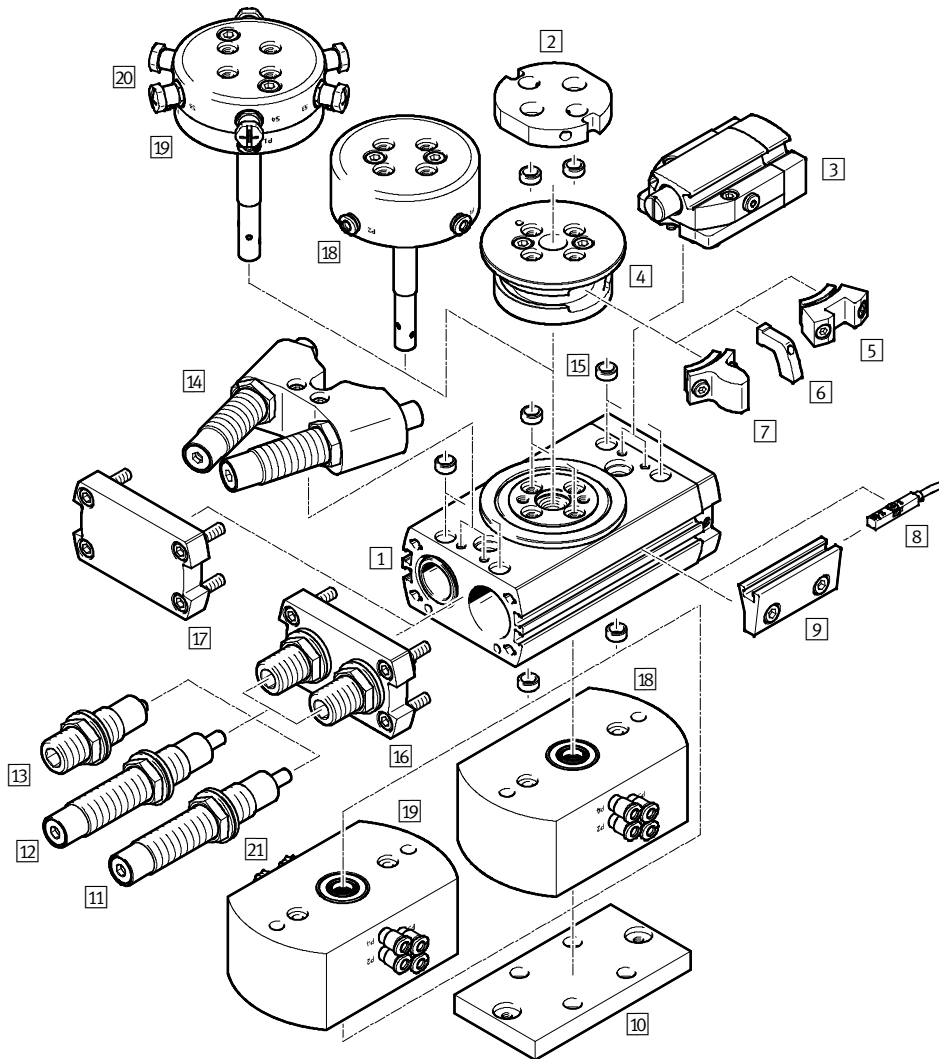

Variants, mounting components and accessories		Size								→ Page/ Internet	
	Brief description	16	20	25	32	35	40	50	63		
1	Semi-rotary drive DRRD	Double-acting	■	■	■	■	■	■	■	■	6
2	Adapter kit DHAA	<ul style="list-style-type: none"> Connecting plate between semi-rotary drive and gripper Included in the scope of delivery: 2 centring sleeves and screws 	■	■	■	■	■	■	■	■	gripper
3	End-position locking E1 (clamping unit DADL-...-EL as an accessory)	<ul style="list-style-type: none"> Mechanical lock in the end positions to prevent unwanted movement in unpressurised condition Included in the scope of delivery: 3, 4, 2x 5 	■	■	■	■	■	■	■	■	29
4	Flange assembly	<ul style="list-style-type: none"> Required to mount components 5, 6 and 7 	■	■	■	■	■	■	■	■	29
5	Clamping component (type: DADL-EC)	<ul style="list-style-type: none"> Secures the semi-rotary drive DRRD when cylinder 3 is advanced Two clamping components are included in the scope of delivery of the end-position locking (E1) 	■	■	■	■	■	■	■	■	31

Twin-piston semi-rotary drives DRRD

Peripherals overview

Variants, mounting components and accessories											
	Brief description	Size								→ Page/ Internet	
		16	20	25	32	35	40	50	63		
6	Switch lug DASI-Q11-...-SL	<ul style="list-style-type: none"> For sensing the piston position using e.g. inductive proximity sensors SIES-8M → 32, in combination with sensor bracket 9 Two switch lugs are included in the scope of delivery of the sensor mounting kit (R) 	■	■	■	■	■	■	■	■	31
7	Stop element	<ul style="list-style-type: none"> Serves as an end stop in combination with external shock absorbers (Y12) Two stop elements are included in the scope of delivery of external shock absorbers (Y12) 	■	■	■	■	■	■	■	■	28
8	Proximity sensor SMT-/SME-8	For sensing the piston position	■	■	■	■	■	■	■	■	32
9	Sensor mounting kit R (sensing kit DASI-...-KT as an accessory)	<ul style="list-style-type: none"> For sensing the piston position using e.g. inductive proximity sensors SIES-8M → 32 Included in the scope of delivery: 4, 2x 6, 2x 9 	■	■	■	■	■	■	■	■	30
10	Adapter kit DHAA	Connecting plate between semi-rotary drive and drive	■	■	■	■	■	■	■	■	adapter
11	Shock absorbers Y9	Linear shock absorber, self-adjusting at both ends	■	■	■	■	■	■	■	■	28
12	Shock absorber, hard Y10	Linear shock absorber, self-adjusting at both ends, hard	-	-	■	-	■	■	■	■	28
13	Shock absorbers P	Elastic cushioning with metal end position, both ends	■	■	■	■	■	■	-	-	28
14	Shock absorber, external Y12	<ul style="list-style-type: none"> Linear shock absorber, self-adjusting at both ends, external Included in the scope of delivery: 4, 2x 7, 14 	■	■	■	■	■	■	■	■	28
15	Centring sleeve ZBH	For centring attachments (two centring sleeves for mounting the semi-rotary drive included in the scope of delivery)	■	■	■	■	■	■	■	■	31
16	End cap	In combination with elastic cushioning P or shock absorber Y9, Y10	■	■	■	■	■	■	■	■	-
17	End cap	In combination with external shock absorber Y12	■	■	■	■	■	■	■	■	-
18	Pneumatic energy throughfeed	Enables the quick and easy pneumatic supply of parts connected to the flange (e.g. gripper)	■	■	■	■	■	■	■	■	20
19	Pneumatic/electrical energy throughfeed	Enables the quick and easy pneumatic/electrical supply of parts connected to the flange (e.g. gripper)	■	■	■	■	■	■	■	■	20
20	Connecting cable NEBU	From the energy throughfeed to the proximity sensor	■	■	■	■	■	■	■	■	33
21	Connecting cable NEBU	From the energy throughfeed to the control	■	■	■	■	■	■	■	■	33

Twin-piston semi-rotary drives DRRD

Type codes

		DRRD	-		-	180	-	FH	-		-		
Product type													
Double-acting													
DRRD	Semi-rotary drive												
Size													
Nominal swivel angle													
180	180°												
Output shaft													
FH	Flanged shaft, hollow												
Energy throughfeed													
-	None												
P2	Pneumatic, 2 channels												
P2E2	Pneumatic, 2 channels; electric, 2 signals												
P4	Pneumatic, 4 channels												
P4E6	Pneumatic, 4 channels; electric, 6 signals												
P8	Pneumatic, 8 channels												
P8E8	Pneumatic, 8 channels; electric, 8 signals												
Cushioning													
P	Elastic cushioning rings/pads at both ends												
Y9	Linear shock absorber, self-adjusting at both ends												
Y10	Linear shock absorber, self-adjusting at both ends, hard												
Y12	Linear shock absorber, self-adjusting at both ends, external												
Position sensing													
A	For proximity sensor												

Twin-piston semi-rotary drives DRRD

Type codes

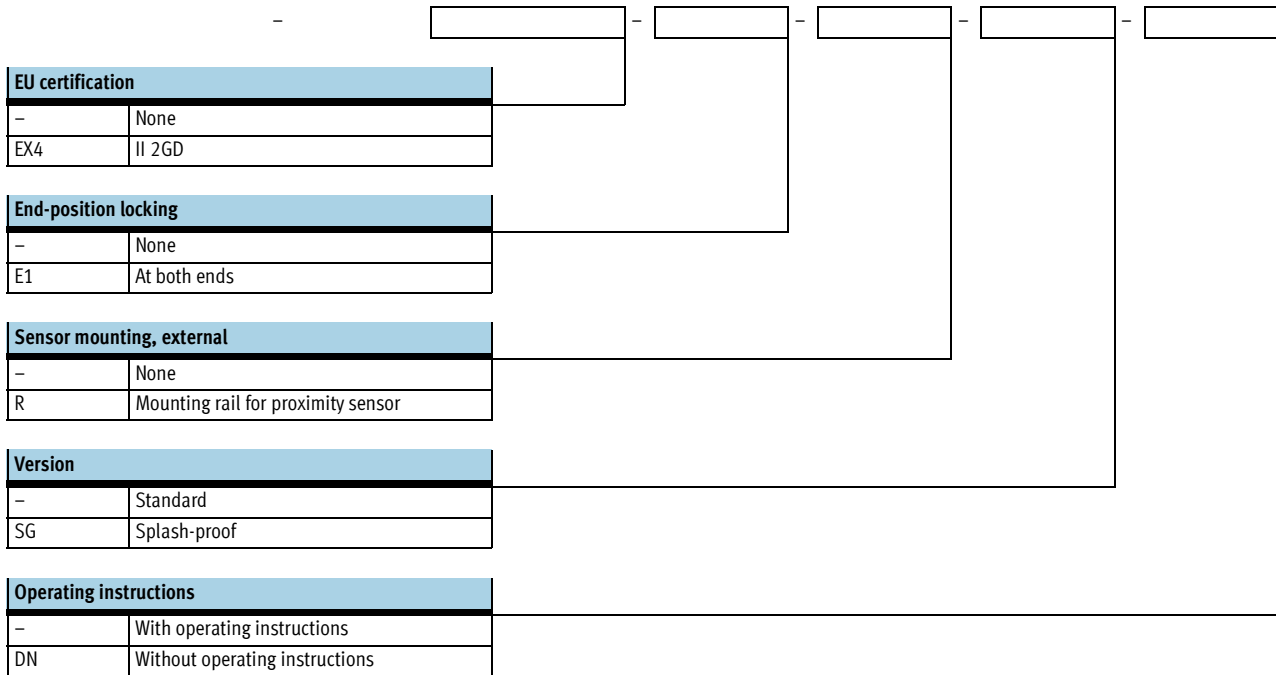

Twin-piston semi-rotary drives DRRD

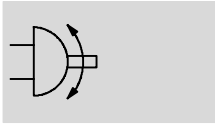

Technical data

Function

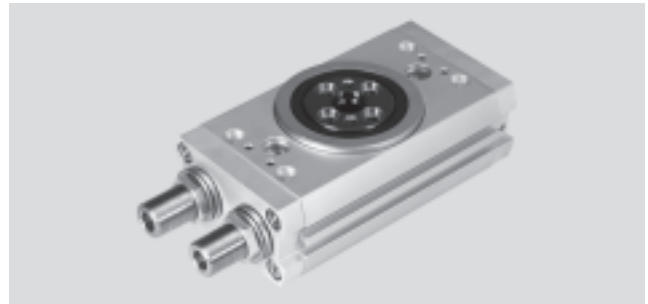

 www.festo.com



-  Diameter
16 ... 63 mm
-  Force
1.6 ... 112 Nm

General technical data									
Size	16	20	25	32	35	40	50	63	
Design	Rack and pinion								
Mode of operation	Double-acting								
Pneumatic connection	M5			G1/8			G1/4		G3/8
Type of mounting	Via through-hole Via female thread								
Swivel angle [°]	180 (→ 11)								
Cushioning with fixed stop									
DRRD-...-P	Elastic cushioning rings/pads at both ends							-	
DRRD-...-Y9	Linear shock absorber, self-adjusting at both ends								
DRRD-...-Y10	-		Linear shock absorber, self-adjusting at both ends, hard		-		Linear shock absorber, self-adjusting at both ends, hard		
DRRD-...-Y12	Linear shock absorber, self-adjusting at both ends, external								
Repetition accuracy [°]	< 0.05						≤0.03		
Axial run-out ¹⁾ [mm]	< 0.05								
Max. axial load (static) [N]	1500	2400	2400	3750	6100	6100	9,000	11,000	
Mounting position	Any								

1) Axial run-out in new condition

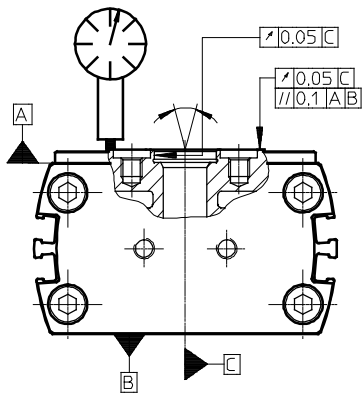

Twin-piston semi-rotary drives DRRD

Technical data

FESTO

Operating and environmental conditions		
Operating medium	Compressed air to ISO 8573-1:2010 [7:4:4]	
Note on operating/pilot medium	Lubricated operation possible (required during subsequent operation)	
Operating pressure		
DRRD-...-P	[bar]	3 ... 8
DRRD-...-Y9/-Y10/-Y12	[bar]	2 ... 10
Ambient temperature	[°C]	-10 ... +60
Storage temperature	[°C]	-20 ... +60
Protection class based on EN 60529		
DRRD-...-SG	IP65	

ATEX ¹⁾	
ATEX category for gas	II 2G
Explosion ignition protection type for gas	c T4
ATEX category for dust	II 2D
Explosion ignition protection type for dust	c T120°C
Explosion-proof ambient temperature	-10°C ≤ Ta ≤ +60°C
CE marking (see declaration of conformity)	To EU Explosion Protection Directive (ATEX)

1) Note the ATEX certification of the accessories.

Weight [g]								
Size	16	20	25	32	35	40	50	63
Basic drive with cushioning								
DRRD-...-P	640	839	1349	2815	4510	6070	-	-
DRRD-...-Y9/-Y10	650	883	1358	2976	4784	6424	11300	19100
DRRD-...-Y12	757	1132	1705	3760	5425	7160	12450	22400
Energy throughfeed (additional)								
DRRD-...-P	320	350	710	920	1090	1470	1950	2250
DRRD-...-P...E...	460	480	720	900	880	1770	2330	2610
End-position locking (additional)								
DRRD-...-E1	166	382	370	600	900	900	1610	2380
Sensor mounting, external (additional)								
DRRD-...-R	110	192	192	366	485	485	810	1390

Twin-piston semi-rotary drives DRRD

Technical data

Forces and torques									
Size		16	20	25	32	35	40	50	63
Theoretical torque at 6 bar	[Nm]	1.6	2.4	5.1	10.1	15.8	24.1	53	112
Max. permissible mass moment of inertia									
DRRD-...-P	[kgcm ²]	175	400	900	1500	2500	6700	-	-
DRRD-...-Y9	[kgcm ²]	700	1250	1500	8,000	15,000	23,000	40,000	40,000
DRRD-...-Y10	[kgcm ²]	-	-	5500	-	45,000	67,000	200,000	420,000
DRRD-...-Y12	[kgcm ²]	900	1500	5500	26,000	45,000	67,000	200,000	420,000

 **Note**

If torque exceeding 50% of the theoretical torque value is applied against the direction of rotation in the end-positions, it's not possible to assure an accurate end-position.

This can be avoided by using an external shock absorber (Y12) or a semi-rotary drive with twice the torque.

Materials

Sectional view

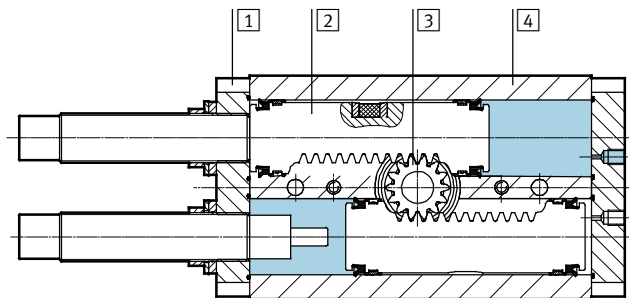

Semi-rotary drive		
1	End cap	Anodised wrought aluminium alloy
2	Piston	Stainless steel
3	Flanged shaft	Tempered steel
4	Housing	Smooth anodised wrought aluminium alloy
	Seals	NBR
	Piston seal	TPE-U(PU)
	Note on materials	RoHS-compliant
		Contains PWIS (paint-wetting impairment substances)

Twin-piston semi-rotary drives DRRD

Technical data

Swivel angle

Fundamentally, the following applies:

Swivel angle $\alpha \geq$ cushioning angle β

Swivel angle $\alpha = 180^\circ + \Delta\alpha_{\text{clockwise}} + \Delta\alpha_{\text{anti-clockwise}}$

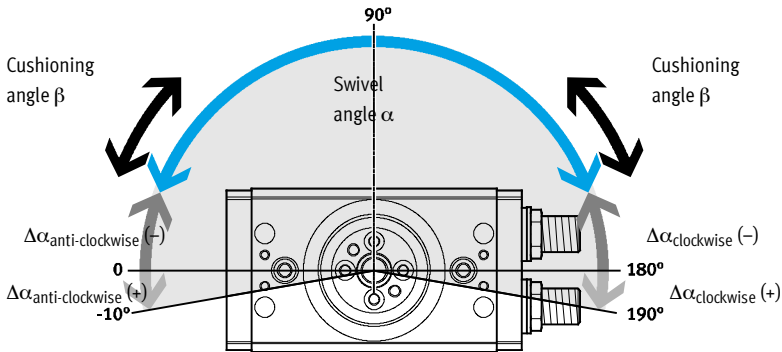

Size	16	20	25	32	35	40	50	63		
Swivel angle α	[°] 180									
Min. swivel angle α										
DRRD-...-P	[°] 36	45	33	33	36	23	-	-		
DRRD-...-Y9/-Y10	[°] 43	72	79	82	85	56	61	48		
DRRD-...-Y12	[°] 20	24	38	34	34	34	30	34		
DRRD-...-E1	[°] 60	60	60	55	57	57	62	55		
Max. swivel angle $\alpha^{1)}$										
DRRD-...	[°] 200									
DRRD-...-Y12	[°] 194	196	190	194	195	195	188	192		
Swivel angle adjustment α per side (infinitely adjustable)										
DRRD-...-P	[°] -100 ... +10								-	-
DRRD-...-Y9/-Y10	[°] ≥ -100 ... +10									
DRRD-...-Y12	[°] -94 ... +7	-85 ... +8	-88 ... +5	-93 ... +7	-86 ... +7			-86 ... +4	-91 ... +6	
Cushioning angle β										
DRRD-...-P	[°] 36	45	33	33	36	23	-	-		
DRRD-...-Y9/-Y10	[°] 43	72	79	82	85	56	61	48		
DRRD-...-Y12	[°] 10	12	19	17	17	17	15	17		

1) The max. swivel angle is reduced by approx. 10° in combination with the external sensor mounting

Swivel angle adjustment

Clockwise direction of rotation:

- Swivel angle decreases

Anti-clockwise direction of rotation:

- Swivel angle increases

The swivel angle is adjusted via the cushioning components using an Allen key. Any reduction in the swivel angle should preferably be evenly split between the two end positions.

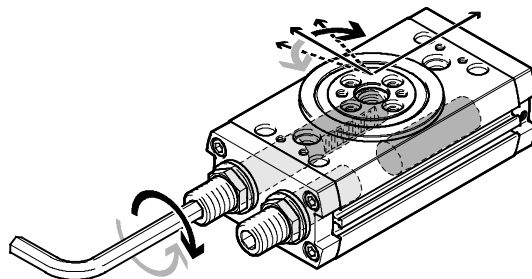

Twin-piston semi-rotary drives DRRD

Technical data

Max. permissible mass moment of inertia J at the flanged shaft as a function of swivel time s
(at room temperature and an operating pressure of 6 bar)

With cushioning P

Size 16

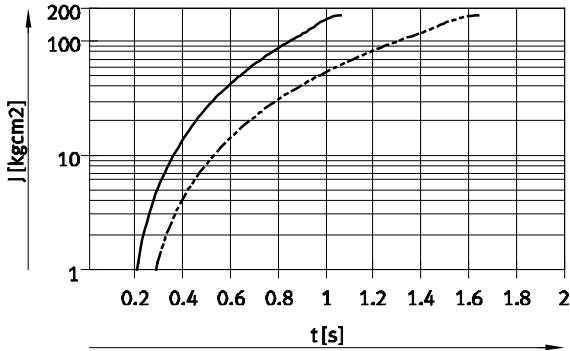

— DRRD-16-...-P (90°) Ranges → 1 ... 175 kgcm²
 - - - DRRD-16-...-P (180°) Ranges → 1 ... 175 kgcm²

Size 20

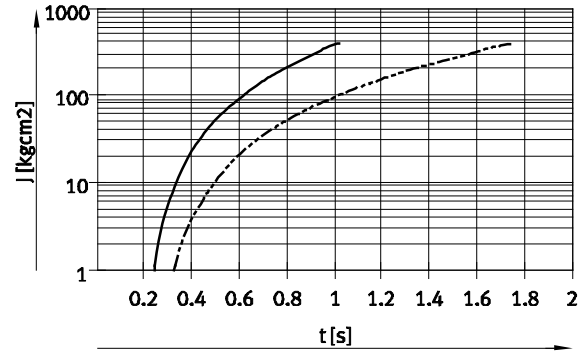

— DRRD-20-...-P (90°) Ranges → 1 ... 400 kgcm²
 - - - DRRD-20-...-P (180°) Ranges → 1 ... 400 kgcm²

Size 25

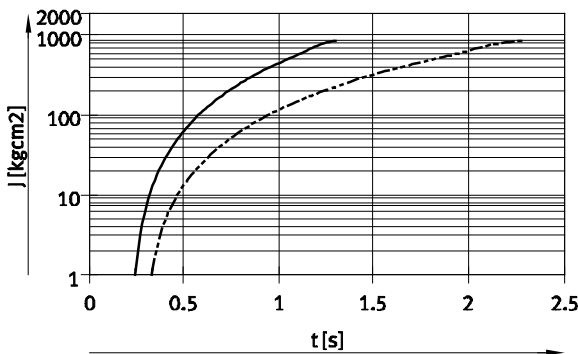

— DRRD-25-...-P (90°) Ranges → 1 ... 900 kgcm²
 - - - DRRD-25-...-P (180°) Ranges → 1 ... 900 kgcm²

Size 32

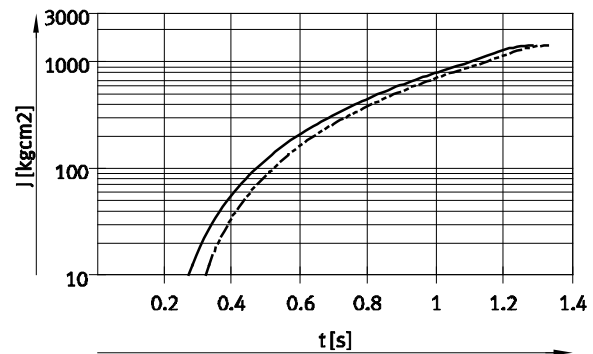

— DRRD-32-...-P (90°) Ranges → 10 ... 1500 kgcm²
 - - - DRRD-32-...-P (180°) Ranges → 10 ... 1500 kgcm²

Size 35

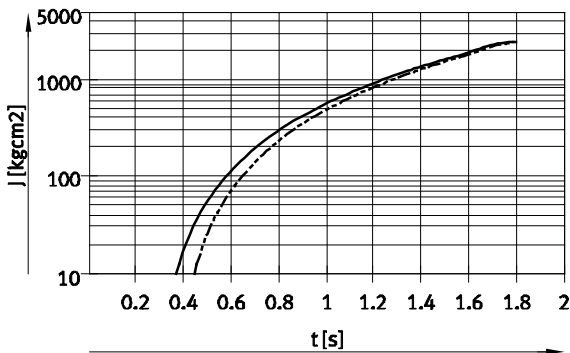

— DRRD-35-...-P (90°) Ranges → 10 ... 2500 kgcm²
 - - - DRRD-35-...-P (180°) Ranges → 10 ... 2500 kgcm²

Size 40

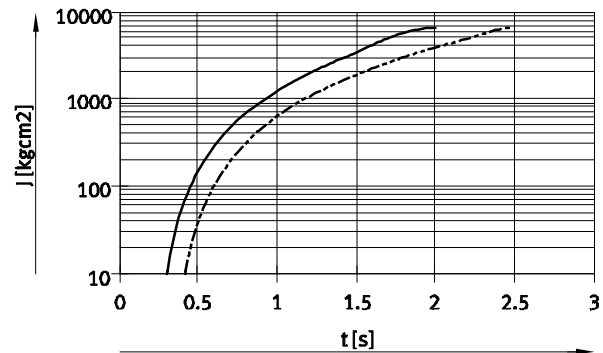

— DRRD-40-...-P (90°) Ranges → 10 ... 6700 kgcm²
 - - - DRRD-40-...-P (180°) Ranges → 10 ... 6700 kgcm²

Twin-piston semi-rotary drives DRRD

Technical data

Max. permissible mass moment of inertia J at the flanged shaft as a function of swivel time s
(at room temperature and an operating pressure of 6 bar)

With cushioning Y9/Y10

Size 16

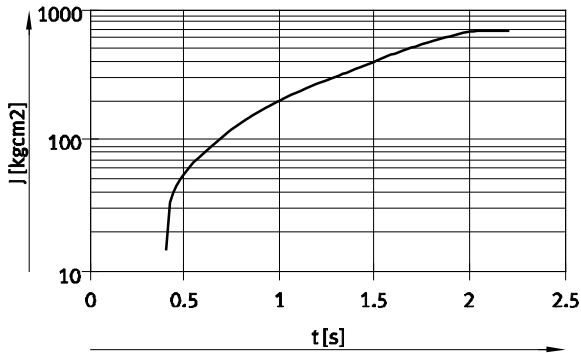

— DRRD-16-180-...-Y9 (180°) Ranges → 15 ... 700 kgcm²

Size 20

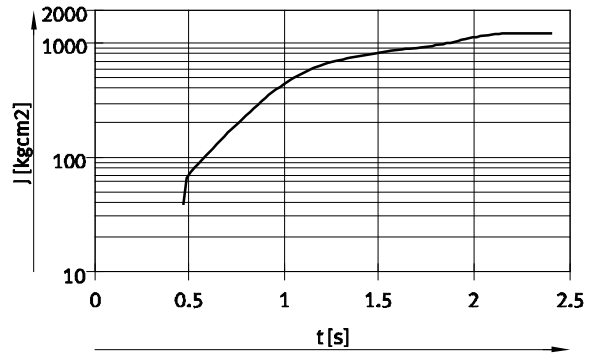

— DRRD-20-180-...-Y9 (180°) Ranges → 40 ... 1250 kgcm²

Size 25

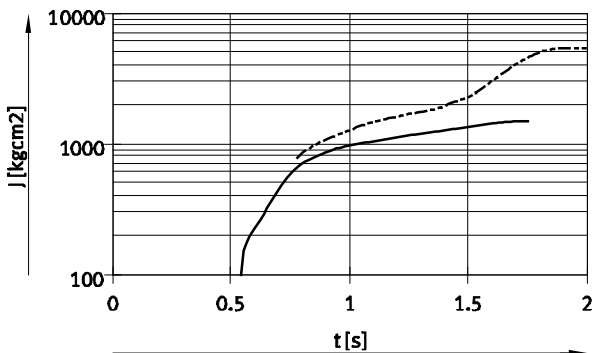

— DRRD-25-180-...-Y9 (180°) Ranges → 100 ... 1500 kgcm²
 - - - DRRD-25-180-...-Y10 (180°) Ranges → 800 ... 5500 kgcm²

Size 32

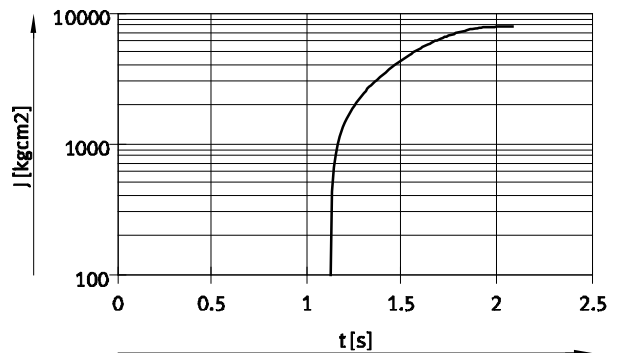

— DRRD-32-180-...-Y9 (180°) Ranges → 100 ... 8,000 kgcm²

Size 35

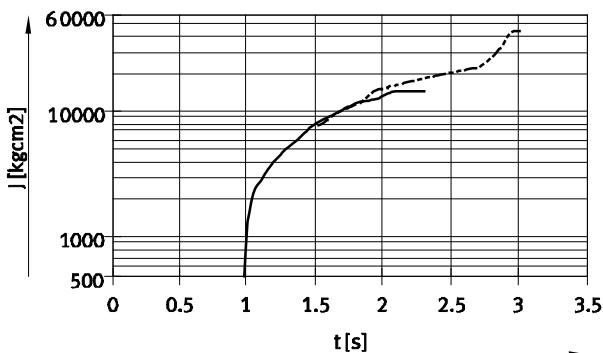

— DRRD-35-180-...-Y9 (180°) Ranges → 500 ... 15,000 kgcm²
 - - - DRRD-35-180-...-Y10 (180°) Ranges → 8,000 ... 45,000 kgcm²

Size 40

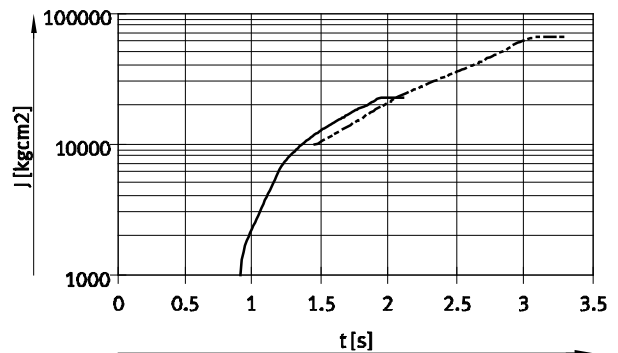

— DRRD-40-180-...-Y9 (180°) Ranges → 1,000 ... 23,000 kgcm²
 - - - DRRD-40-180-...-Y10 (180°) Ranges → 10,000 ... 67,000 kgcm²

Twin-piston semi-rotary drives DRRD

Technical data

Max. permissible mass moment of inertia J at the flanged shaft as a function of swivel time s
(at room temperature and an operating pressure of 6 bar)

With cushioning Y9/Y10

Size 50

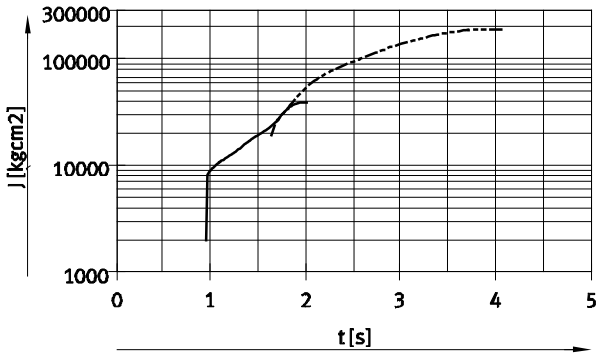

— DRRD-50-180-...-Y9 (180°) → 2,000 ... 40,000 kgcm²
 - - - DRRD-50-180-...-Y10 (180°) → 20,000 ... 200,000 kgcm²

Size 63

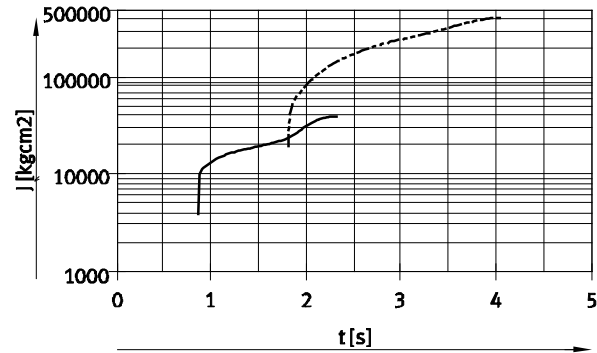

— DRRD-63-180-...-Y9 (180°) → 4,000 ... 40,000 kgcm²
 - - - DRRD-63-180-...-Y10 (180°) → 20,000 ... 420,000 kgcm²

With cushioning Y12

Size 16

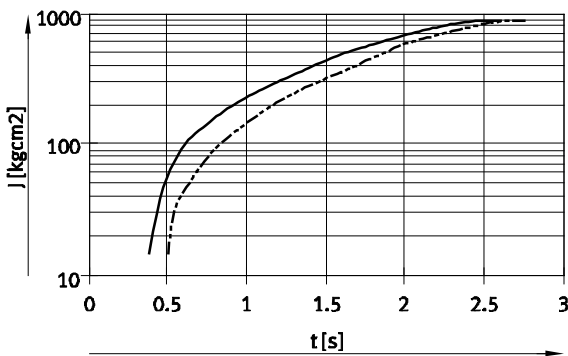

— DRRD-16-...-Y12 (90°) → 15 ... 900 kgcm²
 - - - DRRD-16-...-Y12 (180°) → 15 ... 900 kgcm²

Size 20

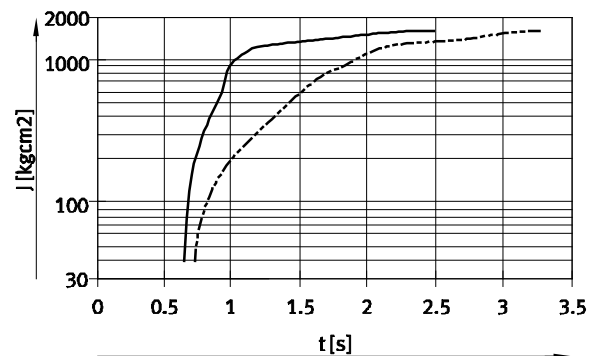

— DRRD-20-...-Y12 (90°) → 40 ... 1500 kgcm²
 - - - DRRD-20-...-Y12 (180°) → 40 ... 1500 kgcm²

Size 25

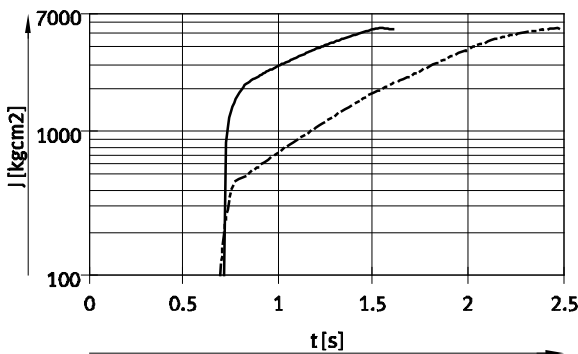

— DRRD-25-...-Y12 (90°) → 100 ... 5500 kgcm²
 - - - DRRD-25-...-Y12 (180°) → 100 ... 5500 kgcm²

Size 32

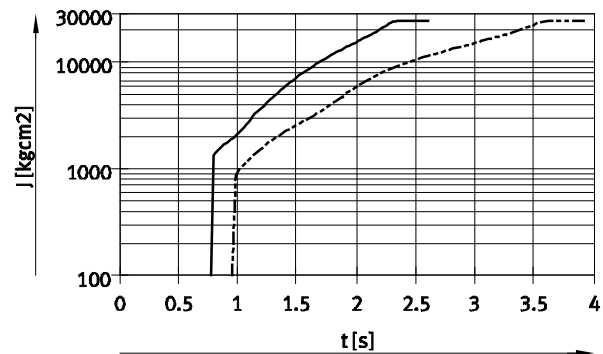

— DRRD-32-...-Y12 (90°) → 100 ... 26,000 kgcm²
 - - - DRRD-32-...-Y12 (180°) → 100 ... 26,000 kgcm²

Twin-piston semi-rotary drives DRRD

Technical data

Max. permissible mass moment of inertia J at the flanged shaft as a function of swivel time s
(at room temperature and an operating pressure of 6 bar)

With cushioning Y12

Size 35

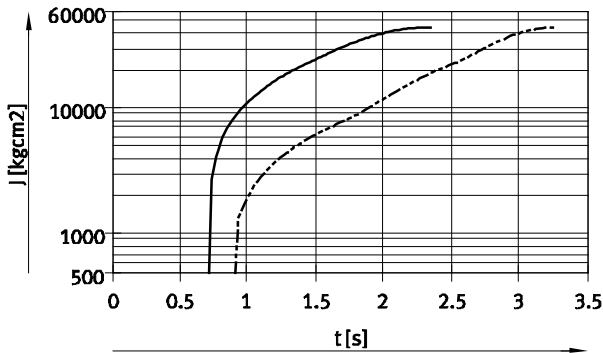

—	DRRD-35-...-Y12 (90°)	Ranges	→ 500 ... 45,000 kgcm ²
- - -	DRRD-35-...-Y12 (180°)		→ 500 ... 45,000 kgcm ²

Size 40

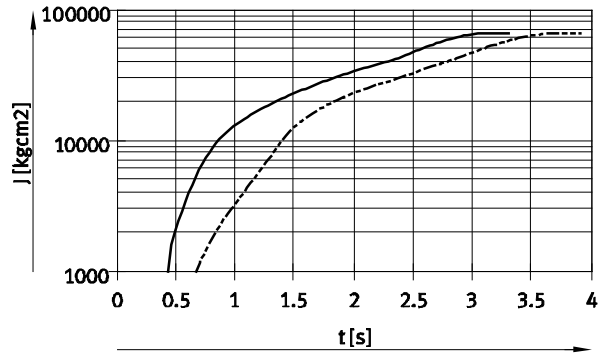

—	DRRD-40-...-Y12 (90°)	Ranges	→ 1,000 ... 67,000 kgcm ²
- - -	DRRD-40-...-Y12 (180°)		→ 1,000 ... 67,000 kgcm ²

Size 50

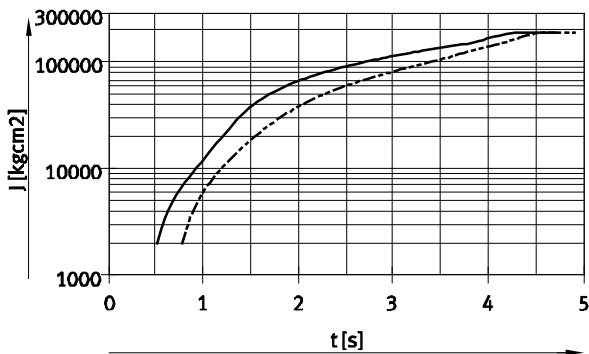

—	DRRD-50-...-Y12 (90°)	Ranges	→ 2,000 ... 200,000 kgcm ²
- - -	DRRD-50-...-Y12 (180°)		→ 2,000 ... 200,000 kgcm ²

Size 63

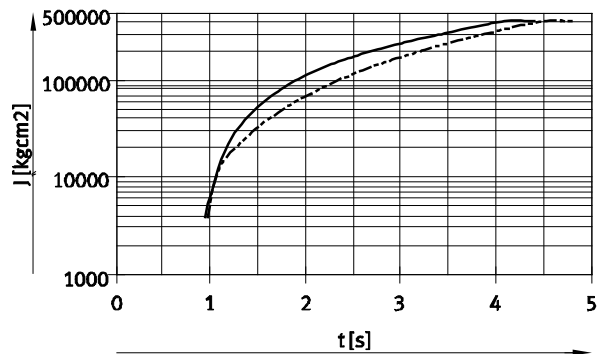

—	DRRD-63-...-Y12 (90°)	Ranges	→ 4,000 ... 420,000 kgcm ²
- - -	DRRD-63-...-Y12 (180°)		→ 4,000 ... 420,000 kgcm ²

Twin-piston semi-rotary drives DRRD

Technical data

Max. dynamic load capacity at the flanged shaft

The zero point for the dimension Z is always the flange surface of the basic drive, regardless of the attachments (flange assembly).

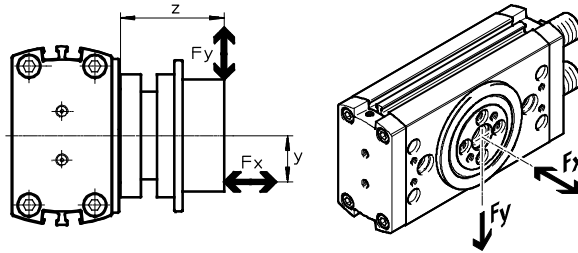

The following equation applies to combined loads (axial and radial):

$$\frac{F_y(z)}{F_{y, \max.}(z)} + \frac{F_z(v)}{F_{z, \max.}(v)} \leq 1$$

Max. dynamic radial force F_y as a function of distance z

Size 16/20

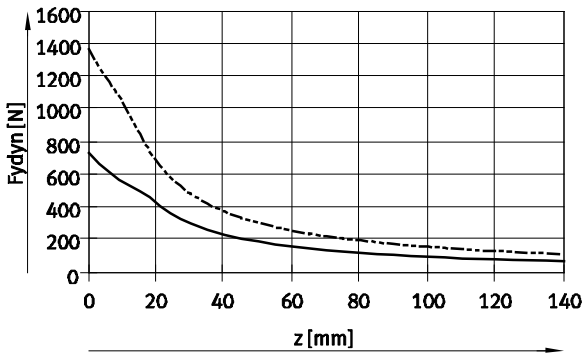

— DRRD-16
- - - DRRD-20

Size 25/32

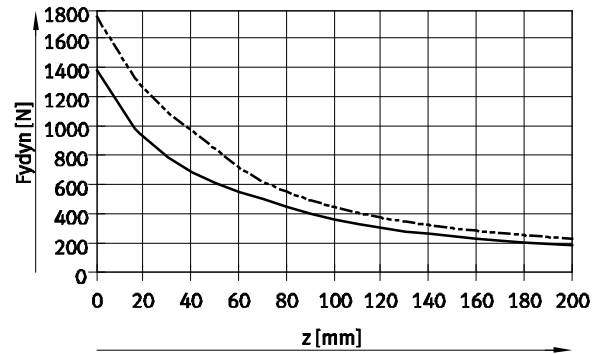

— DRRD-25
- - - DRRD-32

Size 35/40

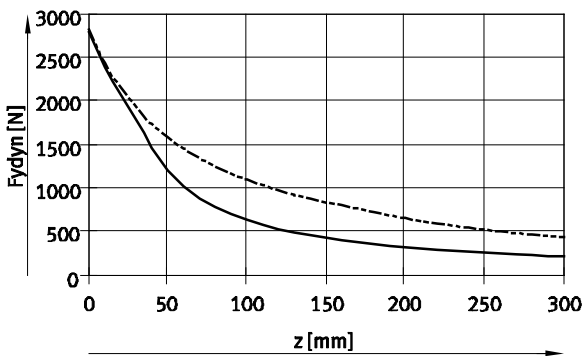

— DRRD-35
- - - DRRD-40

Size 50/63

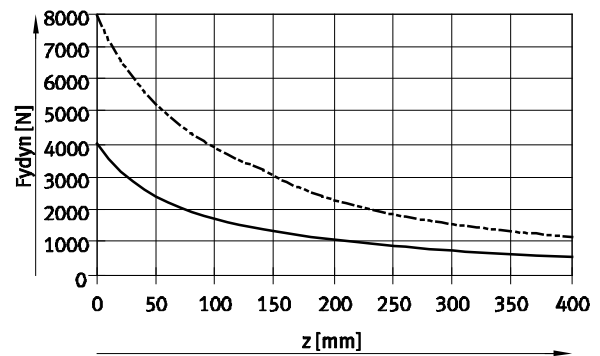

— DRRD-50
- - - DRRD-63

Twin-piston semi-rotary drives DRRD

Technical data

Max. dynamic load capacity at the flanged shaft

The zero point for the dimension Z is always the flange surface of the basic drive, regardless of the attachments (flange assembly).

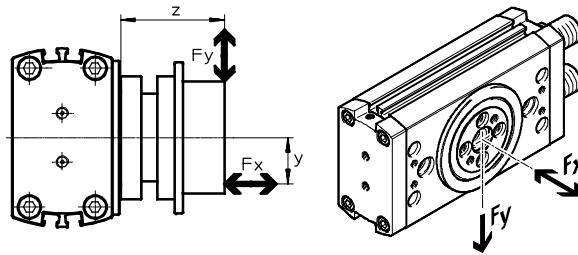

The following equation applies to combined loads (axial and radial):

$$\frac{F_{y(z)}}{F_{y, \max. (z)}} + \frac{F_{z(v)}}{F_{z, \max. (v)}} \leq 1$$

Max. dynamic axial force F_x as a function of distance y

Size 16/20

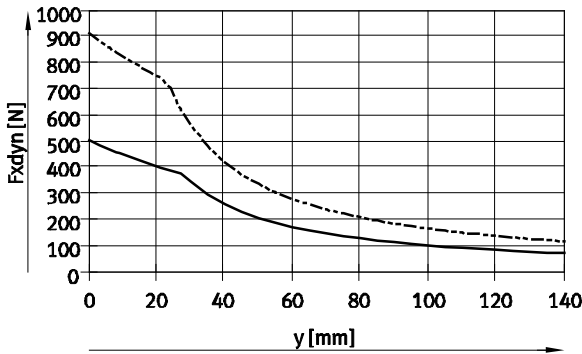

— DRRD-16
- - - DRRD-20

Size 25/32

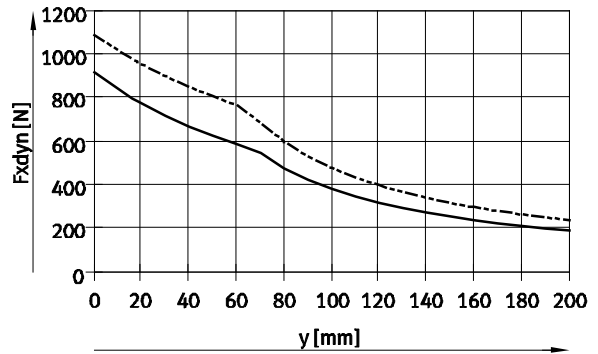

— DRRD-25
- - - DRRD-32

Size 35/40

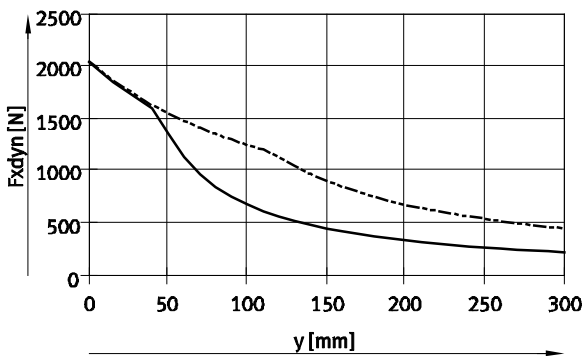

— DRRD-35
- - - DRRD-40

Size 50/63

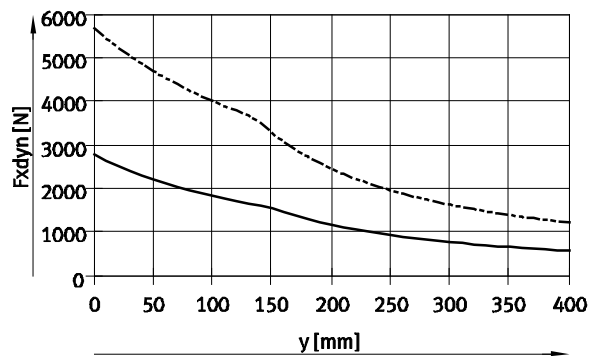

— DRRD-50
- - - DRRD-63

Twin-piston semi-rotary drives DRRD

Technical data

Max. static load capacity at the flanged shaft

The zero point for the dimension Z is always the flange surface of the basic drive, regardless of the attachments (flange assembly).

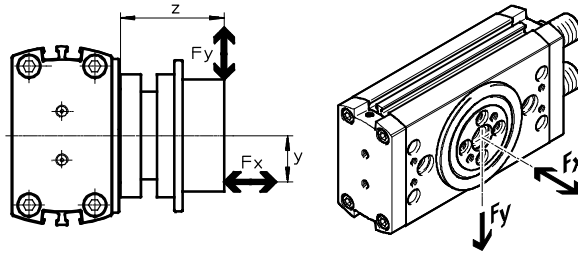

The following equation applies to combined loads (axial and radial):

$$\frac{F_y(z)}{F_{y, \max.}(z)} + \frac{F_z(v)}{F_{z, \max.}(v)} \leq 1$$

Max. static radial force F_y as a function of distance z

Size 16/20

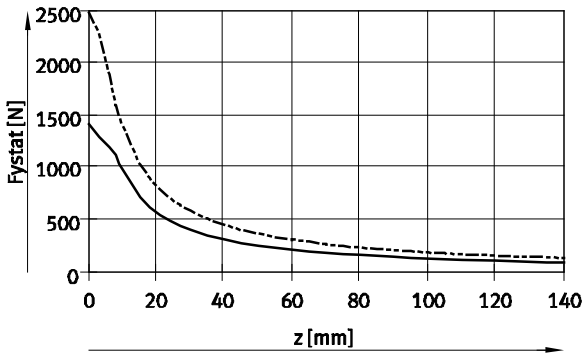

— DRRD-16
- - - DRRD-20

Size 25/32

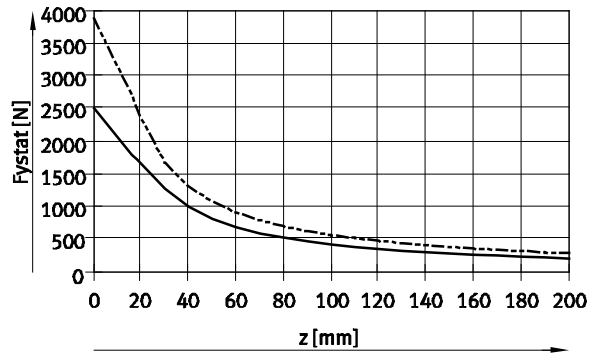

— DRRD-25
- - - DRRD-32

Size 35/40

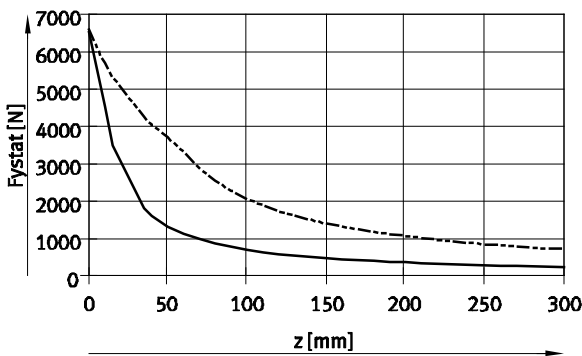

— DRRD-35
- - - DRRD-40

Size 50/63

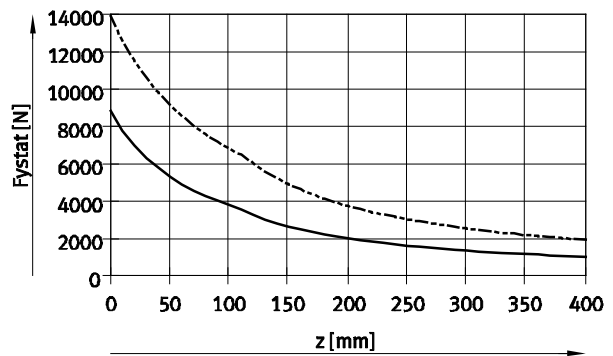

— DRRD-50
- - - DRRD-63

Twin-piston semi-rotary drives DRRD

Technical data

Max. static load capacity at the flanged shaft

The zero point for the dimension Z is always the flange surface of the basic drive, regardless of the attachments (flange assembly).

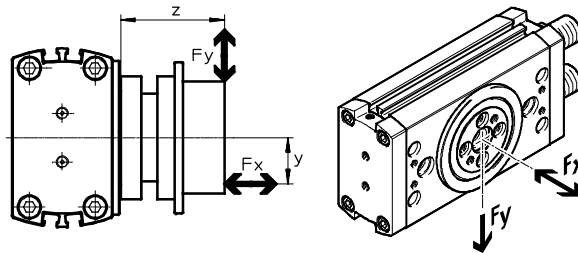

The following equation applies to combined loads (axial and radial):

$$\frac{F_{y(z)}}{F_{y, \max. (z)}} + \frac{F_{z(v)}}{F_{z, \max. (v)}} \leq 1$$

Max. static axial force F_x as a function of distance y

Size 16/20

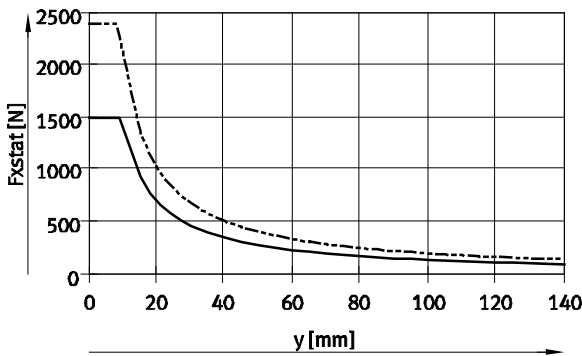

— DRRD-16
- - - DRRD-20

Size 25/32

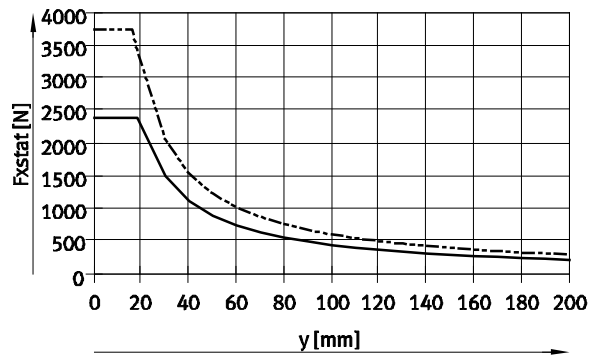

— DRRD-25
- - - DRRD-32

Size 35/40

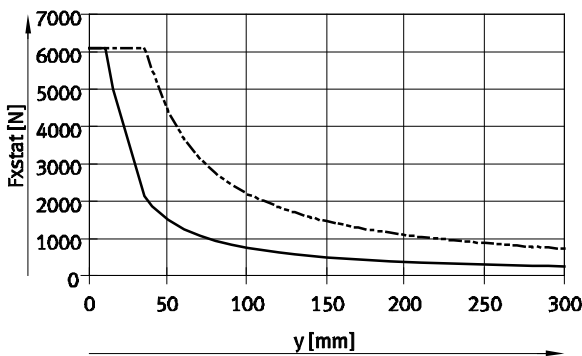

— DRRD-35
- - - DRRD-40

Size 50/63

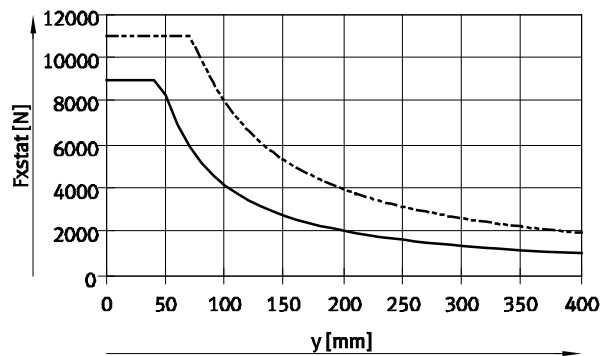

— DRRD-50
- - - DRRD-63

Twin-piston semi-rotary drives DRRD

Technical data

Energy throughfeed

Electric signals or compressed air can be transferred through the hollow shaft using the energy throughfeed.

This enables quick and easy supply of the parts connected to the flange (e.g. gripper). This also prevents any

damage to the compressed air tubes and electrical cables.

- Two versions available:
 - Pneumatic
 - Pneumatic and electrical
- Different number of connections depending on the size

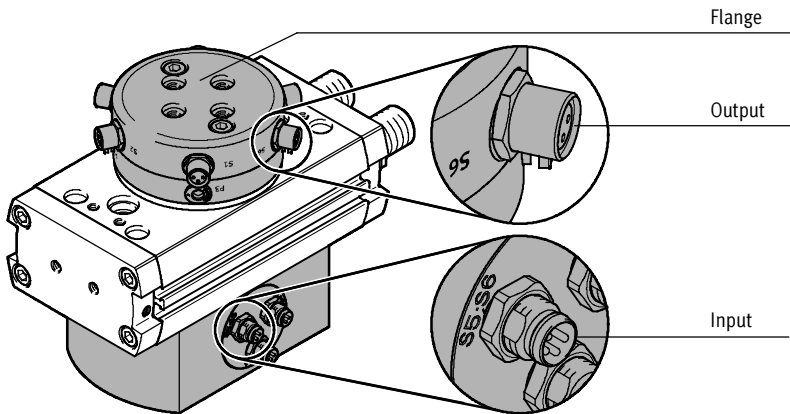



Technical data						
Size	16/20		25/32/35		40/50/63	
Variant	Pneumatic	Pneumatic/ electrical	Pneumatic	Pneumatic/ electrical	Pneumatic	Pneumatic/ electrical
Order code	P2	P2E2	P4	P4E6	P8	P8E8
Pneumatic						
Number of pneumatic channels	2	2	4	4	8	8
Tubing O.D. Ø	4					
Max. operating pressure [bar]	8					
Connection	M5					
Flow rate per channel [l/min.]	86				33	
Electrical						
Number of electric signals	–	2	–	6	–	8
Rated voltage [DC V]	–	30	–	30	–	30
Max. current ¹⁾ [A]	1.5					
Connection	M 8				M12	

1) The positive and negative lines of all electrical connections are connected together. The combined maximum peak current for this common positive and negative line is also 1.5 A.

Pin allocation

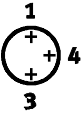
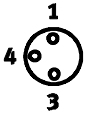
Size 16/20

Input M8 plug				Output M8 socket			
Designation	Signals	Pin ¹⁾	Circuit diagram	Circuit diagram	Pin ¹⁾	Signals	Designation
S1	+ – Sig 1	1			1 3 4	+ – Sig 1	S1
		3					
		4					
S2	+ – Sig 2	1			1 3 4	+ – Sig 2	S2
		3					
		4					

1) Pin 1 (+) and Pin 3 (-) are connected to each other between plugs S1 and S2. Unused plugs and sockets should therefore be protected with the cover caps.







Twin-piston semi-rotary drives DRRD

Technical data

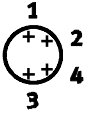
FESTO

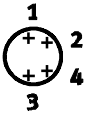

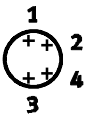

Pin allocation

Sizes 25/32/35

Input M8 plug				Output M8 socket			
Designation	Signals	Pin ¹⁾	Circuit diagram	Circuit diagram	Pin ¹⁾	Signals	Designation
S1;S2	+ Sig 2 - Sig 1	1 2 3 4			1 3 4	+ - Sig 1	S1
					1 3 4	+ - Sig 2	S2
S3;S4	+ Sig 4 - Sig 3	1 2 3 4			1 3 4	+ - Sig 3	S3
					1 3 4	+ - Sig 4	S4
S5;S6	+ Sig 6 - Sig 5	1 2 3 4			1 3 4	+ - Sig 5	S5
					1 3 4	+ - Sig 6	S6

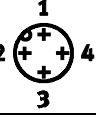
1) Pin 1 (+) and Pin 3 (-) are connected to each other between plugs S1 ... S6. Unused plugs and sockets should therefore be protected with the cover caps.

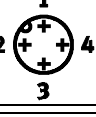
Sizes 40/50/63

Input Plug M12				Output M12 socket			
Designation	Signals	Pin ¹⁾	Circuit diagram	Circuit diagram	Pin ¹⁾	Signals	Designation
S1;S2	+ Sig 2 - Sig 1	1 2 3 4			1 2 3 4	+ Sig 2 - Sig 1	S1;S2
					1 2 3 4	+ Sig 4 - Sig 3	S3;S4
S5;S6	+ Sig 6 - Sig 5	1 2 3 4			1 2 3 4	+ Sig 6 - Sig 5	S5;S6
					1 2 3 4	+ Sig 8 - Sig 7	S7;S8

1) Pin 1 (+) and Pin 3 (-) are connected to each other between plugs S1 ... S8. Unused plugs and sockets should therefore be protected with the cover caps.

Twin-piston semi-rotary drives DRRD

Technical data

Dimensions

Download CAD data → www.festo.com

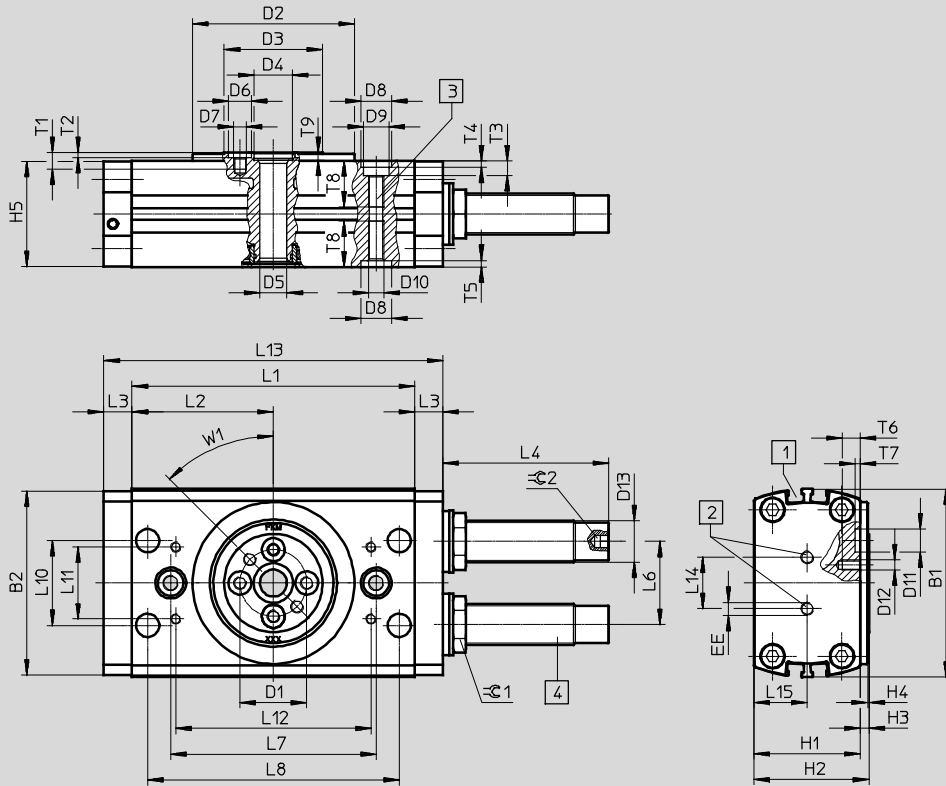

DRRD-32 ... 40

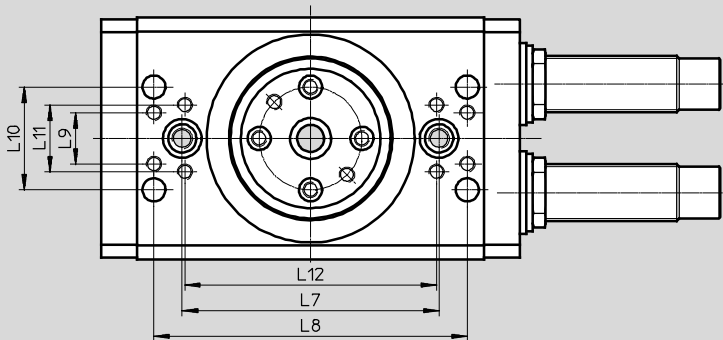

DRRD...-P

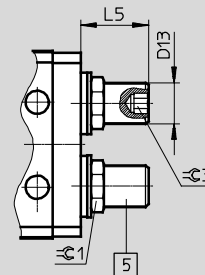

DRRD-50/63

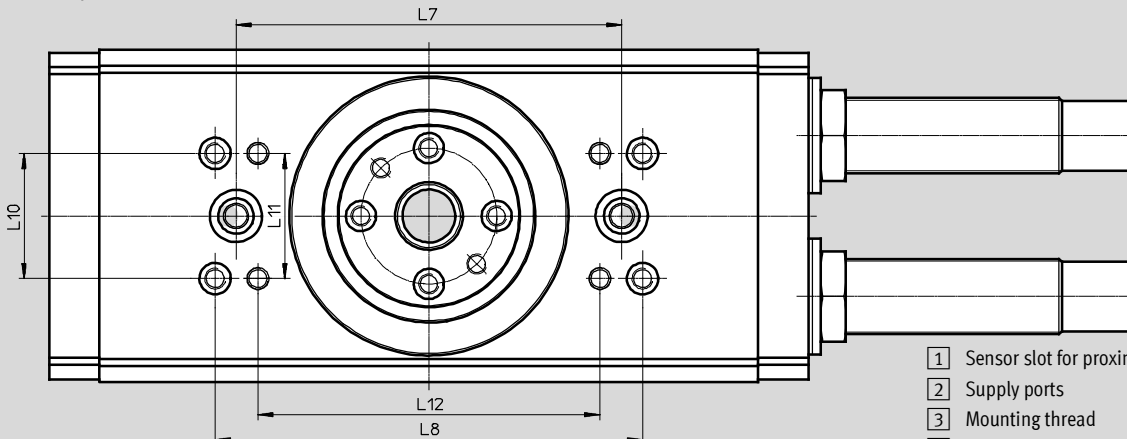

- 1 Sensor slot for proximity sensor
- 2 Supply ports
- 3 Mounting thread
- 4 Shock absorber (DRRD...-Y9/-Y10)
- 5 Cushioning component (DRRD...-P)

Twin-piston semi-rotary drives DRRD

Technical data

Size	B1 ±0.25	B2	D1 ∅ ±0.025	D2 ∅ h7	D3 ∅	D4 ∅	D5 ∅ +0.15/-0.05	D6 ∅ H7	D7	D8 ∅ H7	D9 ∅	D10
16	58	56.2	21	50	32	12	8	7	M4	9	8	M5
20	65	63.4	24	56	34.9	12	8	7	M4	9	8	M5
25	73.2	71.5	26	63	38.3	15	10.5	9	M5	12	10	M6
32	94	92.6	40	81	54.2	15	10.5	9	M6	15	11	M8
35	106	104	45	91	59.9	25	10.5	9	M6	15	11	M8
40	113	111	45	91	59.9	25	21	9	M6	15	14	M10
50	132	139.7	54	110	73	25	21	12	M8	15	14	M10
63	159	157	63	135	82.8	25	21	15	M10	25	17	M12

Size	D11 ∅ H7	D12	D13	H1 ±0.1	H2 +0.2/-0.1	H3 +0.3/-0.2	H4	H5	L1 ±0.1	L2	L3 ±0.1
16	7	M3	M10x1	33	35.6	2.6	0.5	32.6	84	42	10.5
20	9	M4	M12x1	36	39.6	3.6	0.5	35.6	86	43	11
25	9	M4	M16x1	41.4	44.7	3.3	0.5	41	110	55	11
32	9	M6	M22x1.5	50	55.5	5.5	1	49.6	135	67.5	14
35	9	M6	M26x1.5	63	67	4	1	62.2	148	74	15
40	9	M6	M26x1.5	68	72	4	1	67.2	199	99.5	15
50	15	M8	M30x1.5	78	83	5	1	77.2	262	131	20
63	15	M10	M37x1.5	100	107	7	2	99.2	335	167.5	25

Size	L6	L7 ±0.02	L8 ±0.2	L9 ±0.15	L10 ±0.02	L11 ±0.15	L12 ±0.2	L13	L14	L15 -0.1	T1	T2 +0.1
16	23.2	64	74	-	26	22	61	105	20	16.3	5.6	1.6
20	26	70	74	-	33	14	80	108	20	17.8	6	1.6
25	32.4	80	98	-	33	14	98	132	20	20.5	6.6	2.1
32	42.2	100	122	20	40	26	98	163	30	24.8	8	2.1
35	49.6	120	130	44	26	44	105	178	42	31.1	8	2.1
40	56	120	130	44	26	44	105	229	42	33.6	8	2.1
50	64	160	160	34	34	54	132	302	50	39	10.6	2.6
63	78	170	190	60	60	60	149	385	50	49.6	14	3.1

Size	T3	T4 +0.1	T5 +0.3/-0.2	T6	T7 +0.1	T8	T9	EE	W1	∠1	∠2	∠3
16	4.7	2.1	2.1	6.3	1.6	15	2.6	M5	45°	13	3	5
20	4.7	2.1	2.1	6.3	2.1	15	2.6	M5	45°	15	4	6
25	5.7	2.6	2.6	7	2.1	18	3.1	M5	45°	19	5	8
32	6.5	3.1	3.1	7.8	2.1	23.1	3.1	G $\frac{3}{8}$	45°	27	5	10
35	6.5	3.1	3.1	8.5	2.1	22.6	3.5	G $\frac{3}{8}$	45°	32	6	10
40	8.6	3.1	3.1	9	2.1	32	3.5	G $\frac{3}{8}$	45°	32	6	10
50	8.6	3.1	3.1	10.5	3.1	30	3.5	G $\frac{1}{4}$	45°	36	8	-
63	11	3.5	3.5	14	3.1	40	3.5	G $\frac{3}{8}$	45°	46	8	-

Size	Dimension with 180° swivel angle		Swivel angle adjustment range		
	L4	L5	L4 min./max.	L5 min./max.	1 mm = ...°
16	37	17.6	-20/+1.5	-12/+1.4	8.7
20	41.8	18	-21.1/+1.5	-11/+1.4	9
25	63	24.3	-28.9/+1.9	-15/+1.8	6.6
32	78.3	29.5	-34.7/+2.4	-19/+2.3	5.6
35	97.5	40.9	-34.7/+2.4	-27/+2.3	5.6
40	98.2	41.6	-53/+3.2	-28/+3.1	3.6
50	126	-	-74.5/+4.4	-	2.6
63	120	-	-71.7/+7.1	-	1.9

Twin-piston semi-rotary drives DRRD

Technical data

Dimensions – Variants

Download CAD data → www.festo.com

P... – Pneumatic energy throughfeed

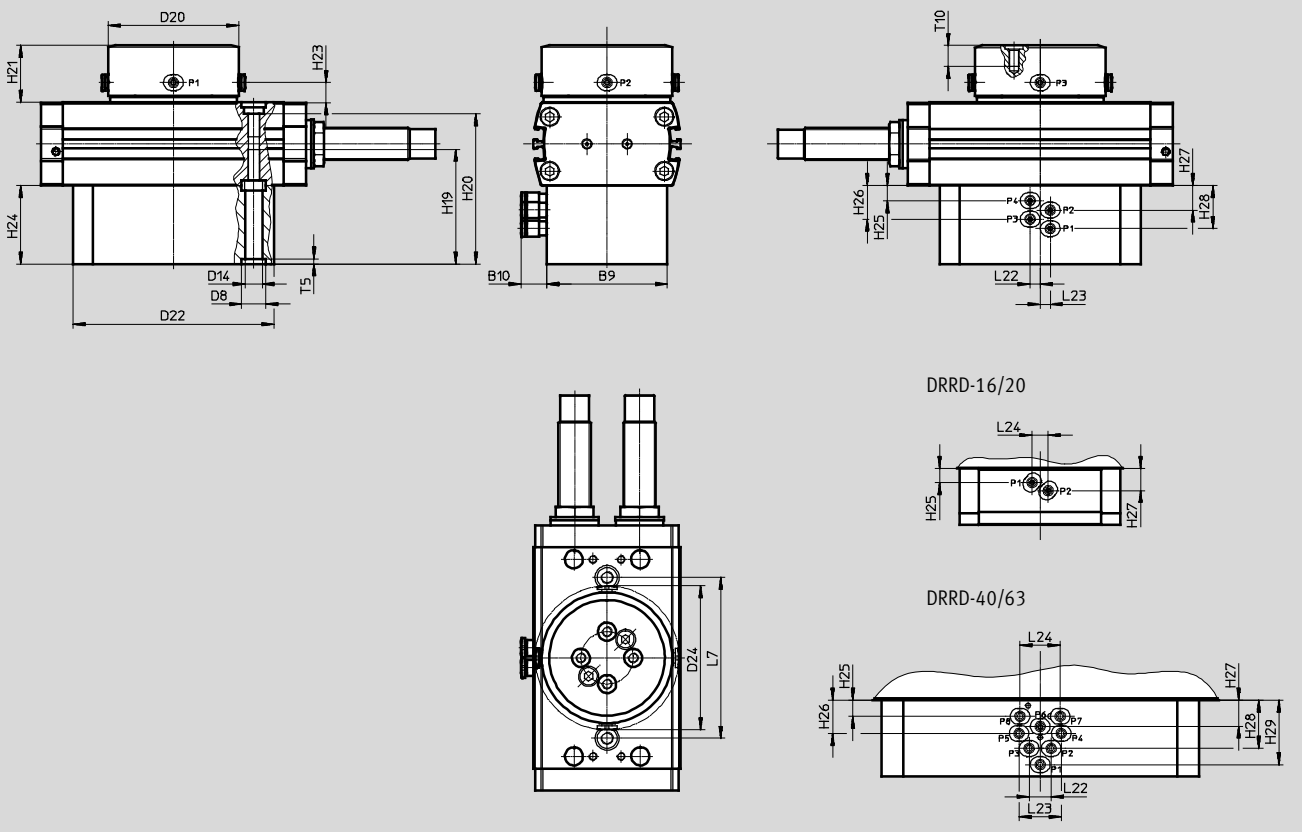

Size	B9	B10	D8 Ø H7	D14 Ø	D20 Ø	D22 Ø	D24 Ø	H19	H20	H21	H23	H24
16	52	13.4	9	6	54	82	70	43.1	56.4	16.6	7.6	28.1
20	58	13.4	9	6	54	82	70	43	59.3	17.6	8.6	28
25	60	12.8	12	6.5	64	100	71.6	57	74.7	28.3	9.8	40
32	70	12.8	15	8.5	64	120	71.6	62	82.4	31.5	12	40
35	80	12.8	15	8.5	64	138	71.6	61.6	95.5	30	10.5	40
40	80	13.4	15	11	89	158	96.9	70	97.4	21	10.5	38
50	80	13.4	15	11	89	190	96.9	68	107.4	24	11.5	38
63	80	13.4	25	13	89	210	96.9	78	127	29	13.5	38

Size	H25	H26	H27	H28	H29	L7	L22	L23	L24	T5	T10
						±0.02				+0.3/-0.2	
16	6.9	–	10.9	–	–	64	4	4	8	2.1	8.6
20	6.9	–	10.9	–	–	70	4	4	8	2.1	8.6
25	7.5	16.7	12.2	21.4	–	80	5	5	–	2.1	9.6
32	7.5	16.7	12.2	21.4	–	100	5	5	–	3.1	11.1
35	7.5	16.7	12.2	21.4	–	120	5	5	–	3.1	11.1
40	7	16.5	13.3	24	32	120	11	21	20	3.1	10.1
50	7	16.5	13.3	24	32	160	11	21	20	3.1	14.6
63	7	16.5	13.3	24	32	170	11	21	20	3.5	17.1

Twin-piston semi-rotary drives DRRD

Technical data

Dimensions – Variants

Download CAD data → www.festo.com

P...E... – Pneumatic/electrical energy throughfeed

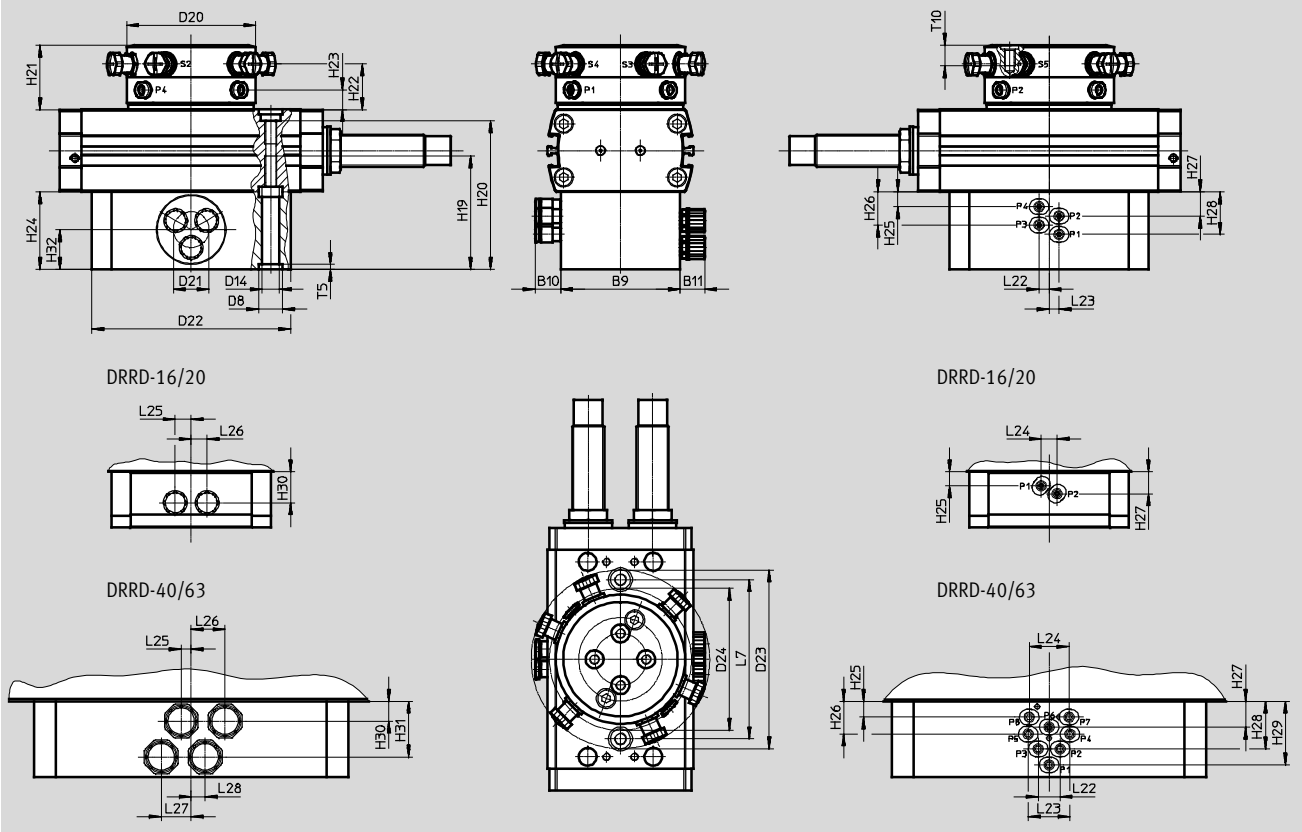

Size	B9	B10	B11	D8 Ø H7	D14 Ø	D20 Ø	D21 Ø	D22 Ø	D23 Ø	D24 Ø	H21	H22	H23	H24	H25	H26
16	52	13.4	8.5	9	6	54	16	82	71.1	70	28.6	21.1	7.6	28.1	6.9	–
20	58	13.4	8.5	9	6	54	16	82	71.1	70	29.6	22.1	8.6	28	6.9	–
25	60	12.8	12.4	12	6.5	64	18	100	89.8	71.6	32.3	22.8	9.8	40	7.5	16.7
32	70	12.8	12.4	15	8.5	64	18	120	89.8	71.6	34.5	25	12	40	7.5	16.7
35	80	12.8	12.4	15	8.5	64	18	138	89.8	71.6	33	23.5	10.5	40	7.5	16.7
40	80	13.4	13	15	11	89	–	158	110.9	96.9	40	28.5	10.5	38	7	16.5
50	80	13.4	13	15	11	89	–	190	110.9	96.9	44	32.5	11.5	38	7	16.5
63	80	13.4	13	25	13	89	–	210	110.9	96.9	48	36.5	13.5	38	7	16.5

Size	H27	H28	H29	H30	H31	H32	L7 ±0.02	L22	L23	L24	L25	L26	L27	L28	T5 +0.3/-0.2	T10
16	10.9	–	–	15.5	–	–	64	4	4	8	8	8	–	–	2.1	8.6
20	10.9	–	–	15.5	–	–	70	4	4	8	8	8	–	–	2.1	8.6
25	12.2	21.4	–	–	–	20	80	5	5	–	–	–	–	–	2.1	9.6
32	12.2	21.4	–	–	–	20	100	5	5	–	–	–	–	–	3.1	11.1
35	12.2	21.4	–	–	–	20	120	5	5	–	–	–	–	–	3.1	11.1
40	13.3	24	32	10	28	–	120	11	21	20	5	17	15	7	3.1	10.1 ¹⁾
50	13.3	24	32	10	28	–	160	11	21	20	5	17	15	7	3.1	14.6 ¹⁾
63	13.3	24	32	10	28	–	170	11	21	20	5	17	15	7	3.5	17.1 ¹⁾

1) The dimensions for variants DRRD-...-P8E8 are T10 = 8 mm

Twin-piston semi-rotary drives DRRD

Technical data

Dimensions – Variants

Download CAD data → www.festo.com

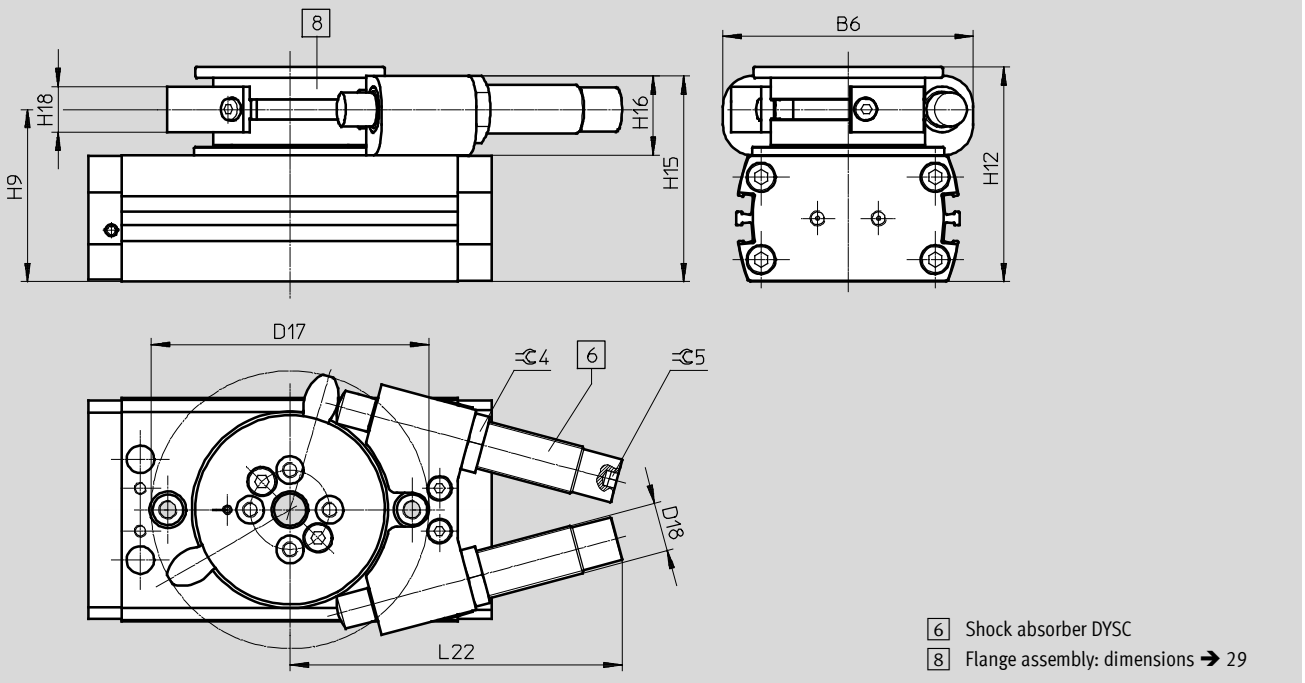

Y12 – With external shock absorber



Size	B6	D17	D18	H9	H12	H15	H16	H18	L22	⌀ C4	⌀ C5
	±0.2								max.		
16	58	69.4	M10x1	43.1	52.6	51	18	10	65.2	13	3
20	75	91	M12x1	51.2	65.2	59.5	23.5	15	85.3	15	4
25	82	91	M16x1	56.5	70.3	67.4	26	15	108.9	19	5
32	120	126.2	M22x1.5	68.5	87	85	35	22	149.7	27	5
35	133	146.7	M26x1.5	83	101	99	36	21	155.5	27	5
40	133	146.7	M30x1.5	88	106	104	36	21	155.5	27	5
50	152	165.2	M30x1.5	101.5	125	123	45	30	171.6	32	6
63	186	212.2	M37x1.5	129.5	159	155.5	55.5	36	233.7	36	8

Twin-piston semi-rotary drives DRRD

Technical data

Ordering data – Stock items				
DRRD	Size	Swivel angle [°]	Part No.	Type
P – Elastic cushioning rings/pads at both ends				
	16	180	1577238	DRRD-16-180-FH-PA
	20		1395606	DRRD-20-180-FH-PA
	25		1359980	DRRD-25-180-FH-PA
	32		1578512	DRRD-32-180-FH-PA
	35		1526825	DRRD-35-180-FH-PA
	40		1503269	DRRD-40-180-FH-PA
Y9 – Linear shock absorber, self-adjusting at both ends				
	16	180	1644389	DRRD-16-180-FH-Y9A
	20		1427379	DRRD-20-180-FH-Y9A
	25		1360248	DRRD-25-180-FH-Y9A
	32		1578518	DRRD-32-180-FH-Y9A
	35		1547102	DRRD-35-180-FH-Y9A
	40		1526986	DRRD-40-180-FH-Y9A

Twin-piston semi-rotary drives DRRD

Ordering data – Modular product

Ordering table											
Size	16	20	25	32	35	40	50	63	Condi- tions	Code	Entry code
M Module No.	574399	574400	574401	574402	574403	574404	574405	574407			
Function	Semi-rotary drive									DRRD	DRRD
Size	16	20	25	32	35	40	50	63		-...	
Nominal swivel angle	180°									-180	-180
Output shaft	Flanged shaft, hollow									-FH	-FH
O Energy throughfeed	None									-	
	Pneumatic, 2 channels		-							P2	
	Pneumatic, 2 channels; electric, 2 signals		-							P2E2	
	-		Pneumatic, 4 channels			-				P4	
	-		Pneumatic, 4 channels; electric, 6 signals			-				P4E6	
	-		-			Pneumatic, 8 channels				P8	
	-		-			Pneumatic, 8 channels; electric, 8 signals				P8E8	
M Cushioning	Elastic cushioning rings/pads at both ends						-			-P	
	Linear shock absorber, self-adjusting at both ends						-			-Y9	
	-		Linear shock absorber, self- adjusting at both ends, hard		-			Linear shock absorber, self-adjusting at both ends, hard		-Y10	
	Linear shock absorber, self-adjusting at both ends, external						1 4		-Y12		
Position sensing	For proximity sensor									A	A
O EU certification	None										
	II 2GD									2	-EX4
End-position locking	None										
	At both ends									3 4	-E1
Sensor mounting, external	None										
	Mounting rail for proximity sensor									4	-R
Version	Standard										
	Splash-proof design										-SG
Operating instructions	With operating instructions										
	Without operating instructions										-DN

- 1 **Y12** Not with end-position locking E1 and splash-proof design SG
- 2 **EX4** Not with end-position locking E1 and energy throughfeed P2E2, P4E6, P8E8
- 3 **E1** Not with sensor mounting R and splash-proof design SG
- 4 **Y12, E1, R** Not with energy throughfeed P2, P2E2, P4, P4E6, P8, P8E8

Transfer order code

DRRD - - **180** - **FH** - - - **C** - - - - - -

Twin-piston semi-rotary drives DRRD

Accessories

Clamping unit DADL-EL

(order code: E1)

Stock items

Material:

Housing: Anodised aluminium

Bearing: Plastic

RoHS-compliant

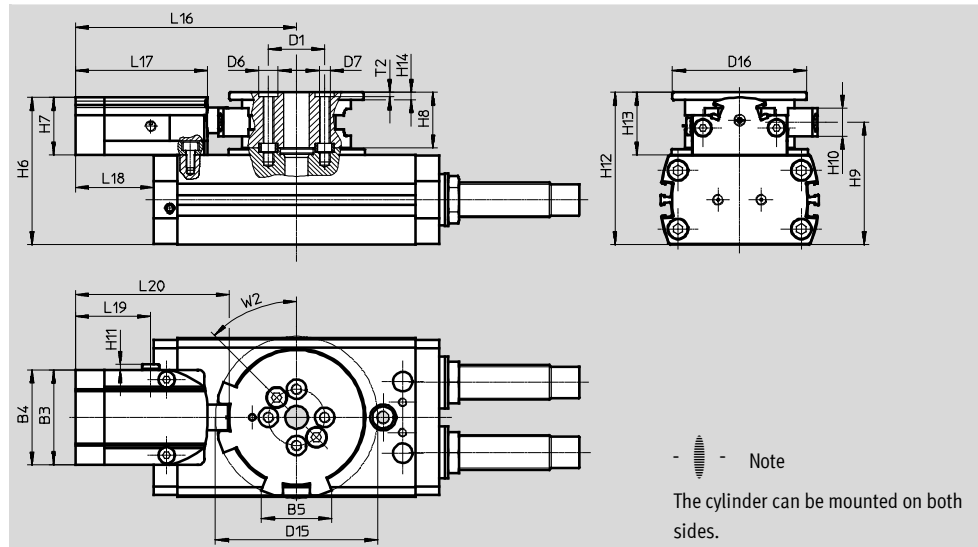
Dimensions and ordering data

For size	B3	B4	B5	D1	D6	D7	D15	D16	H6	H7	H8	H9
	±0.2	±0.2		∅ ±0.025	∅ H7		∅	∅			±0.15	±0.1
16	37.6	38	26.9	21	7	M4	61.9	49	51	18	17	43.1
20	43.6	44	32.4	24	7	M4	74.9	62	62.5	26.5	25.6	51.2
25	43.6	44	32.4	26	9	M5	74.9	62	67.9	26.5	25.6	56.5
32	43.6	44	39.4	40	9	M6	95.4	79	79	26.7	31.5	68.5
35	57.6	58	50.2	45	9	M6	110.9	89	98	35	34	83
40	57.6	58	50.2	45	9	M6	110.9	89	103	35	34	88
50	71.4	72	59.6	54	12	M8	124.3	110	123	45	42	101.5
63	71.4	72	65.8	63	15	M10	148.5	130	149	49	52	129.5

For size	H10	H11	H12	H13	H14	L16	L17	L18	L19	L20	T2	W2
											+0.1	
16	9	2.5	52.6	19.6	3.5	83	50	30.5	34	58.3	1.6	45°
20	13	2.5	65.2	29.2	3.5	102.2	61.2	48.2	34.8	71.1	1.6	45°
25	13	2.5	70.3	28.9	3.5	102.2	61.2	36.2	34.8	71.1	2.1	45°
32	17	2.5	87	37	4	112.2	61.2	30.7	34.8	71.1	2.1	45°
35	14.8	2.5	101	38	5	132.5	70.6	43.5	42.6	85.4	2.1	45°
40	14.8	2.5	106	38	5	132.5	70.6	18	42.6	85.4	2.1	45°
50	19	4.6	125	47	6	151	81	0	46	98	2.6	45°
63	22	4.6	159	59	6	163	81	-29.5	46	99.5	3.1	45°

For size	Pneumatic connection	Operating pressure [bar]	Position sensing	Adjustable swivel angle [°]	Weight [g]	Part No.	Type			
16	M5	5 ... 8	For proximity sensor	60 ... 200	166	1692770	DADL-EL-Q11-16			
20					382	1579786	DADL-EL-Q11-20			
25					370	1568183	DADL-EL-Q11-25			
32				G ¹ / ₈			55 ... 200	600	1631139	DADL-EL-Q11-32
35								900	1544900	DADL-EL-Q11-35/40
40							900	1544900	DADL-EL-Q11-35/40	
50							62 ... 200	1 610	1796637	DADL-EL-Q11-50
63	55 ... 200	2,380	1941568	DADL-EL-Q11-63						

Twin-piston semi-rotary drives DRRD

Accessories

Sensing kit DASI-...-KT

(order code: R)

Stock items

Material:

Anodised aluminium

RoHS-compliant

Also with inductive proximity sensor

SIES for sensing the piston position

→ 32

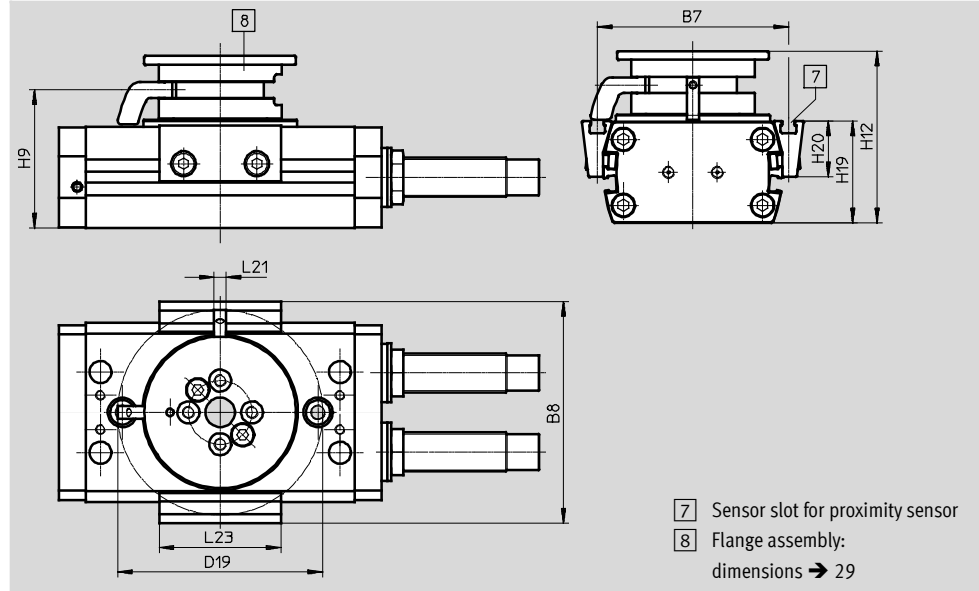





Dimensions and ordering data						
For size	B7	B8	D19 Ø	H9	H12	H19
16	64.4	76.1	70.9	43.1	52.6	33.5
20	74	85.7	84	51.2	65.2	36.4
25	78.2	90.7	84	56.5	70.3	41.8
32	100	113.5	107.5	68.5	87	50.5
35	116	132.9	125.2	83	101	63.5
40	118	135.8	125.2	88	106	68.5
50	136	155.3	146.6	101.5	125	79.1
63	163	185.3	173.9	129.5	159	101

For size	H20 ±0.1	L21	L23	Weight [g]	Part No.	Type ¹⁾
16	18.5	5	50	110	1693008	DASI-Q11-16-A-KT
20	20.2	5	50	192	1580899	DASI-Q11-20-A-KT
25	22.8	5	50	192	1568461	DASI-Q11-25-A-KT
32	26.5	7	50	366	1632097	DASI-Q11-32-A-KT
35	33.1	7	50	485	1551144	DASI-Q11-35-A-KT
40	35.5	7	50	485	1550027	DASI-Q11-40-A-KT
50	43	7	50	810	1797135	DASI-Q11-50-A-KT
63	55	7	50	1,390	1946877	DASI-Q11-63-A-KT

1) Suitable for ATEX areas

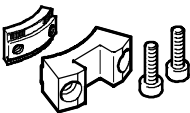
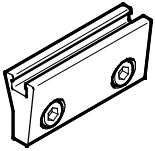
Twin-piston semi-rotary drives DRRD

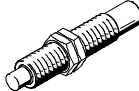
Accessories

Ordering data ³⁾						
	For size	Brief description	Weight [g]	Part No.	Type	PU ¹⁾
Clamping component DADL-EC⁴⁾						
	16	For securing an intermediate position in combination with the clamping unit DADL-EL	18	1692496	DADL-EC-Q11-16	1
	20, 25		36	1435411	DADL-EC-Q11-20/25	
	32		67	1631170	DADL-EC-Q11-32	
	35, 40		98	1535091	DADL-EC-Q11-35/40	
	50		140	1796626	DADL-EC-Q11-50	
	63		220	1941355	DADL-EC-Q11-63	
	Sensor bracket DASI-...-SR⁴⁾					
	16	Additional sensing option in combination with the sensing kit DASI-...-KT	28	1692983	DASI-Q11-16-A-SR	2
	20		32	1581420	DASI-Q11-20-A-SR	
	25		32	1568451	DASI-Q11-25-A-SR	
	32		42	1631997	DASI-Q11-32-A-SR	
	35		62	1550870	DASI-Q11-35-A-SR	
	40		62	1548054	DASI-Q11-40-A-SR	
	50		75	1797071	DASI-Q11-50-A-SR	
	63		110	1971563	DASI-Q11-63-A-SR	
	Switch lug DASI-...-SL⁴⁾					
	16	Additional sensing option in combination with the sensing kit DASI-...-KT	2.5	1692969	DASI-Q11-16-A-SL	1
	20, 25		4	1568436	DASI-Q11-20/25-A-SL	
	32		6	1631824	DASI-Q11-32-A-SL	
	35, 40		8	1548155	DASI-Q11-35/40-A-SL	
	50		10	1797021	DASI-Q11-50-A-SL	
	63		15	1971550	DASI-Q11-63-A-SL	
	Shock absorber DYSC⁴⁾					
	16	<ul style="list-style-type: none"> • Self-adjusting shock absorber • Included in the scope of delivery for semi-rotary drive DRRD-...-Y12 	17	548012	DYSC-7-5-Y1F	1
	20		36	548013	DYSC-8-8-Y1F	
	25		81	548014	DYSC-12-12-Y1F	
	32, 35, 40		210	553593	DYSC-16-18-Y1F	
	50		370	2479149	DYSC-20-18-Y1F	
	63		575	2480234	DYSC-25-25-Y1F	
	Centring sleeve ZBH²⁾4)					
	16, 20	For centring the semi-rotary drive	1	150927	ZBH-9	10
	25		1	189653	ZBH-12	
	32 ... 50		3	191409	ZBH-15	
	63		5	8023856	ZBH-25	
	16, 20		1	186717	ZBH-7	
	25 ... 40	1	150927	ZBH-9		
	50	1	189653	ZBH-12		
	63	3	191409	ZBH-15		

1) Packaging unit quantity

2) 2 included in the scope of delivery of the semi-rotary drive or attachments



3) Stock items

4) Suitable for ATEX areas

Twin-piston semi-rotary drives DRRD

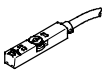
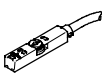

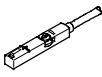
Accessories

Ordering data – Proximity sensor for T-slot, magneto-resistive						Technical data → Internet: smt
	Type of mounting	Switching output	Electrical connection	Cable length [m]	Part No.	Type
N/O contact						
	Insertable in the slot from above, flush with the cylinder profile, short design	PNP	Cable, 3-wire	2.5	574335	SMT-8M-A-PS-24V-E-2,5-OE
			Plug M8x1, 3-pin	0.3	574334	SMT-8M-A-PS-24V-E-0,3-M8D
			Plug M12x1, 3-pin	0.3	574337	SMT-8M-A-PS-24V-E-0,3-M12
		NPN	Cable, 3-wire	2.5	574338	SMT-8M-A-NS-24V-E-2,5-OE
			Plug M8x1, 3-pin	0.3	574339	SMT-8M-A-NS-24V-E-0,3-M8D
N/C contact						
	Insertable in the slot from above, flush with the cylinder profile, short design	PNP	Cable, 3-wire	7.5	574340	SMT-8M-A-PO-24V-E-7,5-OE

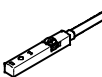
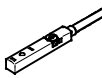
Ordering data – Proximity sensors for T-slot, magnetic reed						Technical data → Internet: sme	
	Type of mounting	Switching output	Electrical connection	Cable length [m]	Part No.	Type	
N/O contact							
	Insertable in the slot from above, flush with the cylinder profile	Contacting	Cable, 3-wire	2.5	543862	SME-8M-DS-24V-K-2,5-OE	
				5.0	543863	SME-8M-DS-24V-K-5,0-OE	
			Plug M8x1, 3-pin	Cable, 2-wire	2.5	543872	SME-8M-ZS-24V-K-2,5-OE
				0.3	543861	SME-8M-DS-24V-K-0,3-M8D	
	Insertable in the slot lengthwise, flush with the cylinder profile	Contacting	Cable, 3-wire	2.5	150855	SME-8-K-LED-24	
			Plug M8x1, 3-pin	0.3	150857	SME-8-S-LED-24	

Ordering data – Proximity sensor for T-slot, inductive						Technical data → Internet: sies
	Type of mounting	Switching output	Electrical connection	Cable length [m]	Part No.	Type
N/O contact						
	Insertable in the slot from above, flush with the cylinder profile	PNP	Cable, 3-wire	7.5	551386	SIES-8M-PS-24V-K-7,5-OE
			Plug M8x1, 3-pin	0.3	551387	SIES-8M-PS-24V-K-0,3-M8D
		NPN	Cable, 3-wire	7.5	551396	SIES-8M-NS-24V-K-7,5-OE
			Plug M8x1, 3-pin	0.3	551397	SIES-8M-NS-24V-K-0,3-M8D
				N/C contact		
	Insertable in the slot from above, flush with the cylinder profile	PNP	Cable, 3-wire	7.5	551391	SIES-8M-PO-24V-K-7,5-OE
			Plug M8x1, 3-pin	0.3	551392	SIES-8M-PO-24V-K-0,3-M8D
		NPN	Cable, 3-wire	7.5	551401	SIES-8M-NO-24V-K-7,5-OE
			Plug M8x1, 3-pin	0.3	551402	SIES-8M-NO-24V-K-0,3-M8D

 **Note**
 The inductive proximity sensors SIES can only be used in combination with the sensing kit DASI-...-KT.

Ordering data – Connecting cables					Technical data → Internet: nebu
	Electrical connection, left	Electrical connection, right	Cable length [m]	Part No.	Type
	Straight socket, M8x1, 3-pin	Cable, open end, 3-wire	2.5	541333	NEBU-M8G3-K-2.5-LE3
			5	541334	NEBU-M8G3-K-5-LE3
	Angled socket, M8x1, 3-pin	Cable, open end, 3-wire	2.5	541338	NEBU-M8W3-K-2.5-LE3
			5	541341	NEBU-M8W3-K-5-LE3

Twin-piston semi-rotary drives DRRD

Accessories

Wiring of the proximity sensor only in combination with the energy throughfeed

Size 16/20

Sizes 25/32/35

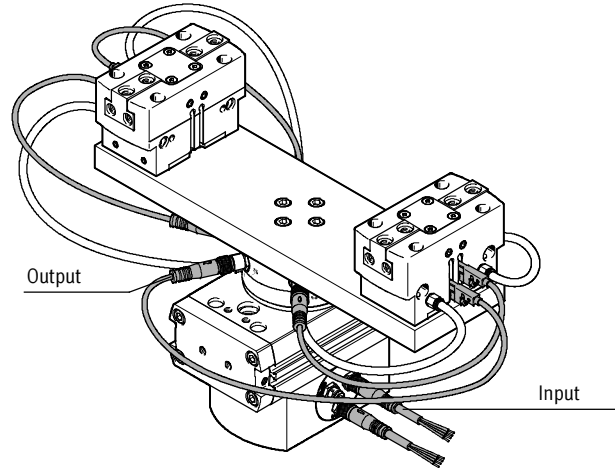
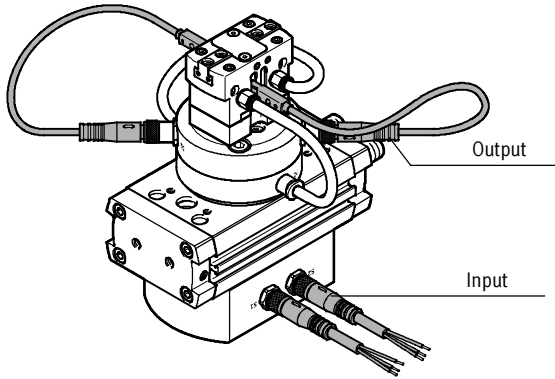

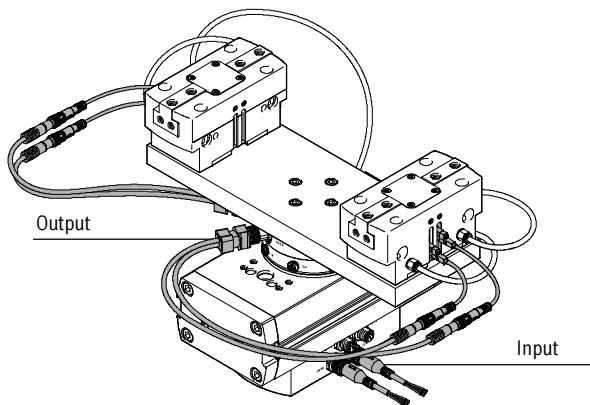

Sizes 40/50/63



 Note

Proximity sensors with plug connectors must be used for attachments (e.g. grippers) at the output. On sizes 16 ... 35 these can be connected directly to the energy

throughfeed module. On sizes 40 ... 63, the proximity sensors must be connected to the energy throughfeed module using a push-in T-connector.

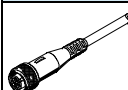
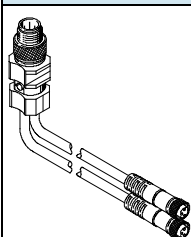
Ordering data				Technical data → Internet: nebu	
	Electrical connection, left	Electrical connection, right	Cable length [m]	Part No.	Type
Input – Connecting cable					
Size 16/20					
	Straight socket, M8x1, 3-pin	Cable, open end, 3-wire	2.5	541333	NEBU-M8G3-K-2.5-LE3
	Straight socket, M8x1, 3-pin	Cable, open end, 3-wire	5	541334	NEBU-M8G3-K-5-LE3
Sizes 25/32/35					
	Straight socket, M8x1, 4-pin	Cable, open end, 4-wire	2.5	541342	NEBU-M8G4-K-2.5-LE4
	Straight socket, M8x1, 4-pin	Cable, open end, 4-wire	5	541343	NEBU-M8G4-K-5-LE4
Sizes 40/50/63					
	Straight socket, M12x1, 5-pin	Cable, open end, 4-wire	2.5	550326	NEBU-M12G5-K-2.5-LE4
	Straight socket, M12x1, 5-pin	Cable, open end, 4-wire	5	541328	NEBU-M12G5-K-5-LE4
Output – Push-in T-connector					
Sizes 40/50/63					
	Straight plug, M12x1, 4-pin	2x straight socket, M8x1, 3-pin	0.5	18685	KM12-DUO-M8-GDGD
	Straight plug, M12x1, 4-pin	2x angled sockets, M8x1, 3-pin	0.5	18687	KM12-DUO-M8-WDWD