

Standard cylinders DNCl, with measured-value transducer DADE



Standard cylinders DNCI, with measured-value transducer DADE

Features



Components for positioning and measuring using the standard cylinder DNCI



Measuring with measured-value transducer DADE

Measured-value transducer DADE-...



PLC control, e.g. FEC-...



Operator unit e.g. FED-...



Positioning with end-position controller SPC11 or controller module CPX-CMAX/-CMPX

Proportional directional control valve MPYE-...



Proportional directional control valve VPWP-...



End-position controller SPC11-INC



Sensor interface CASM-S-D3-R7



Controller module CPX-CMAX, CPX-CMPX



Standard cylinders DNCI, with measured-value transducer DADE

Type codes

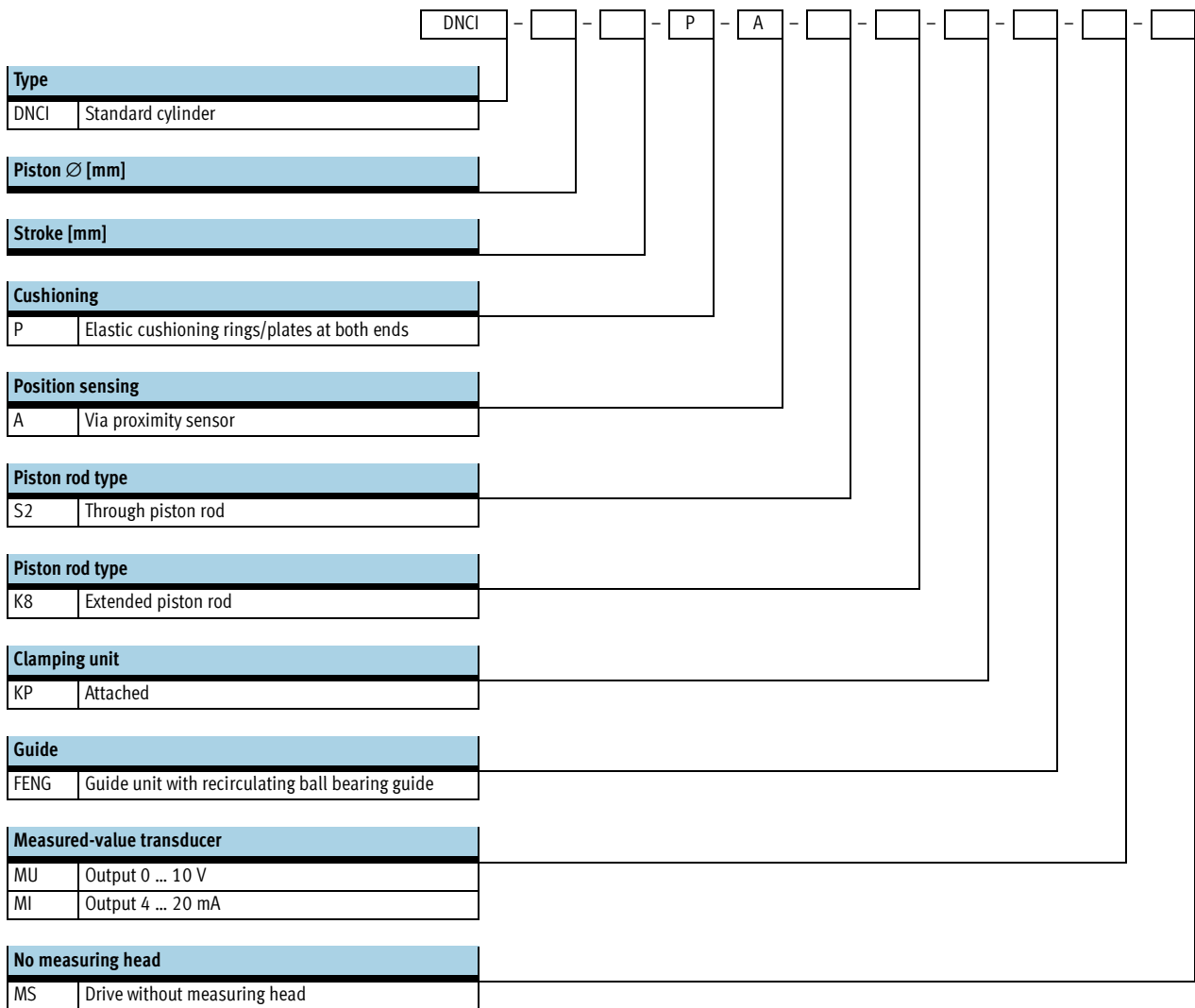

Standard cylinders DNCl, with measured-value transducer DADE

Peripherals overview

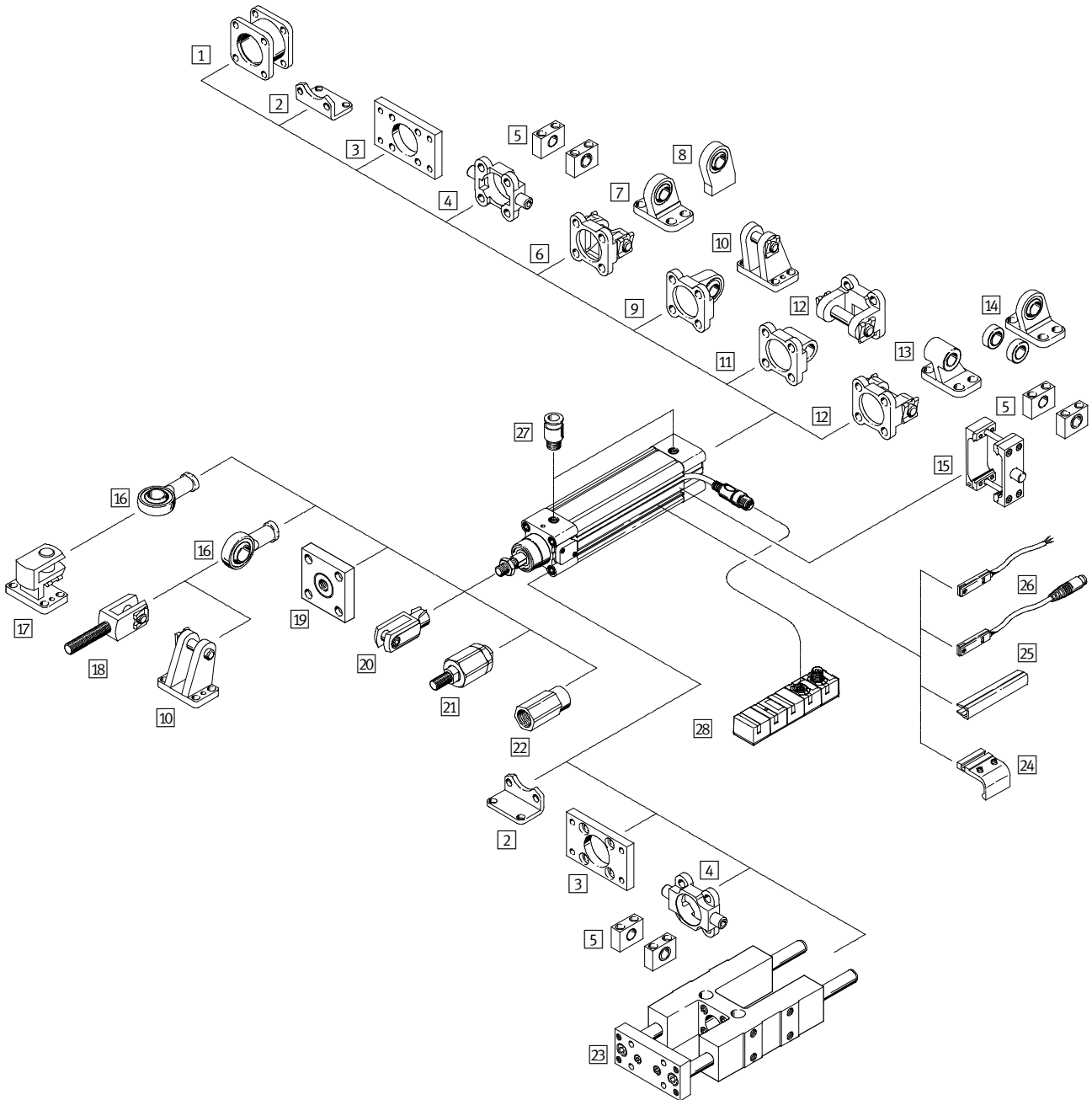

Accessories		
Type	Brief description	→ Page/Internet
1 Adapter kit ¹⁾ DPNC	For connecting two cylinders with identical piston \varnothing to form a multi-position cylinder	dpnc
2 Foot mounting HNC	For mounting the drive on the bearing and end caps	hnc
3 Flange mounting FNC	For mounting the drive on the bearing and end caps	fnc
4 Trunnion flange ZNCf/CRZNG	For swivelling movements of the drive on the bearing or end caps	trunnion flange
5 Trunnion support LNZG/CRLNZG	-	lnzg

Standard cylinders DNCl, with measured-value transducer DADE

Peripherals overview

Accessories		
Type	Brief description	→ Page/Internet
6 Swivel flange ¹⁾ SNC	For swivelling movements of the drive on the end cap	snc
7 Clevis foot mounting ¹⁾ LSNG	With spherical bearing	lsng
8 Clevis foot mounting ¹⁾ LSNSG	Weld-on, with spherical bearing	lsnsg
9 Swivel flange ¹⁾ SNCS	For swivelling movements of the drive on the end cap, with spherical bearing	sncs
10 Clevis foot mounting ¹⁾ LBG	–	lbg
11 Swivel flange ¹⁾ SNCL	For swivelling movements of the drive on the end cap	sncl
12 Swivel flange ¹⁾ SNCB	For swivelling movements of the drive on the end cap	sncb
13 Clevis foot mounting ¹⁾ LNG/CRLNG	–	lng
14 Clevis foot mounting ¹⁾ LSN	With spherical bearing	lsn
15 Trunnion mounting kit ZNCM	For swivelling movements of the drive	zncm
16 Rod eye SGS/CRSGS	With spherical bearing	sgs
17 Right-angle clevis foot LQG	–	lqg
18 Rod clevis SGA	With male thread	sga
19 Coupling piece KSG	To compensate for radial deviations	ksg
Coupling piece KSZ	For cylinders with a non-rotating piston rod to compensate for radial deviations	ksz
20 Rod clevis SG/CRSG	Permits a swivelling movement of the cylinder in one plane	sg
21 Self-aligning rod coupler FK	For compensating radial and angular misalignments	fk
22 Adapter AD	For a suction cup with connection attachments	ad
23 Guide unit FENG	For protecting standard cylinders against rotation at high torque loads	12
24 Mounting kit SMB-8-FENG	For mounting proximity sensors SME/SMT-8 in combination with guide unit FENG	smb-8-feng
25 Slot cover ABP-5-S	For protecting the sensor cable and keeping dirt out of the sensor slots	abp
26 Proximity sensor SME/SMT-8	Can be integrated in the cylinder profile barrel	proximity sensor
27 Push-in fitting QS	For connecting outer toleranced compressed air tubing	quick star
28 Measured-value transducer MU, MI	Converts sensor signals of the standard cylinder DNCl into a voltage signal of 0 ... 10 V and/or a current signal of 4 ... 20 mA	16

1) Not with variant S2

2) Guide unit FENG-KF must be attached to the piston rod in a way that eliminates backlash

Standard cylinders DNCI, with measured-value transducer DADE

FESTO

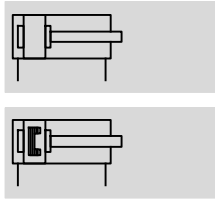

Technical data

Function



 www.festo.com



-  - Diameter
32 ... 63 mm
-  - Stroke length
10 ... 2000 mm

General Technical data				
Piston Ø	32	40	50	63
Based on standard	ISO 15552			
Design	Piston			
	Piston rod			
	Profile barrel			
Mode of operation	Double-acting			
Guide ¹⁾	Guide rod with yoke, with ball bearing guide			
Mounting position	Any			
Type of mounting	Via accessories			
Cushioning	Elastic cushioning rings/plates at both ends			
Position sensing	Integrated displacement encoder			
	Via proximity sensor ²⁾			
Measuring principle (displacement encoder)	Encoder, contactless and relative measurement			
Pneumatic connection	G1/8	G1/4	G1/4	G3/8
Stroke	DNCI-... ³⁾	[mm]	10 ... 2,000	
	DNCI-...-FENG	[mm]	100 ... 500	
	Extended piston rod	[mm]	1 ... 500	

- 1) Guide unit FENG-KF can be ordered via the modular product system (feature FENG) and is supplied attached. The maximum stroke is restricted.
- 2) Not included in the scope of delivery, can be ordered as an option
- 3) Can only be used without restriction as a positioning drive in the range from 100 ... 750 mm.
Note stroke reduction in combination with CPX-CMAX, SPC200

Operating and environmental conditions		
Operating pressure	[bar]	0.6 ... 12
Operating pressure ¹⁾	[bar]	4 ... 8
Operating medium ²⁾		Compressed air to ISO 8573-1:2010 [6:4:4]
Note on operating/pilot medium		Lubricated operation not possible Pressure dew point 10°C below ambient/medium temperature
Ambient temperature ³⁾	[°C]	-20 ... +80
Vibration resistance to DIN/IEC 68, Part 2-6		Severity level 2
Continuous shock resistance to DIN/IEC 68, Part 2-82		Severity level 2
CE marking (see declaration of conformity ⁴⁾)		To EU EMC Directive
Corrosion resistance class CRC ⁵⁾		1

- 1) Only applies to applications with end-position controller CPX-CMPX, SPC11 and axis controller CPX-CMAX, SPC200
- 2) The proportional directional control valve VPWP, MPYE requires these characteristic values
- 3) Note operating range of proximity sensors
- 4) For information about the applicability of the component see the manufacturer's EC declaration of conformity at: www.festo.com → Support → User documentation.
If the component is subject to restrictions on usage in residential, office or commercial environments or small businesses, further measures to reduce the emitted interference may be necessary.
- 5) Corrosion resistance class 1 according to Festo standard 940 070
Components subject to low corrosion stress. Transport and storage protection. Parts that do not have primarily decorative surface requirements, e.g. in internal areas that are not visible or behind covers.

Standard cylinders DNCI, with measured-value transducer DADE

Technical data

Forces [N] and impact energy [Nm]					
Piston Ø		32	40	50	63
Theoretical force at 6 bar		483	754	1,178	1,870
Advancing	S2	415	633	990	1,682
Theoretical force at 6 bar		415	633	990	1,682
Retracting	S2	415	633	990	1,682
Impact energy at the end positions		0.1	0.2	0.2	0.5

Permissible impact velocity:

$$v_{perm.} = \sqrt{\frac{2 \times E_{perm.}}{m_{intrinsic} + m_{Load}}}$$

$v_{perm.}$ Permissible impact velocity

$E_{perm.}$ Maximum impact energy

$m_{intrinsic}$ Moving mass (drive)

m_{Load} Moving payload

Maximum permissible load:

$$m_{Load} = \frac{2 \times E_{perm.}}{v^2} - m_{intrinsic}$$

 Note
These specifications represent the maximum values that can be achieved. Note the maximum permissible impact energy.

Electrical data – displacement encoder		
Output signal		Analogue
Linearity error		
Strokes up to 500 mm	[mm]	< ±0.08
Strokes up to 1,000 mm	[mm]	< ±0.09
Strokes above 1,000 mm	[mm]	< ±0.11
Maximum travel speed	[m/s]	1.5
Protection class		IP65
CE marking (see declaration of conformity)		To EU EMC Directive ¹⁾
Maximum permitted magnetic interference field ²⁾	[kA/m]	10
Electrical connection		Cable with 8-pin plug, round design, M12
Cable length	[m]	1.5

- 1) For information about the applicability of the component see the manufacturer's EC declaration of conformity at: www.festo.com → Support → User documentation.
If the component is subject to restrictions on usage in residential, office or commercial environments or small businesses, further measures to reduce the emitted interference may be necessary.
- 2) At a distance of 100 mm

Pin allocation for plug

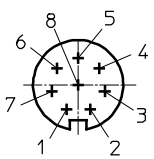

Pin	Function	Colour
1	5V	Black
2	GND	Brown
3	sin+	Red
4	sin-	Orange
5	cos-	Green
6	cos+	Yellow
7	Screened	Screened
8	n.c.	-

Standard cylinders DNCI, with measured-value transducer DADE

Technical data

Weight [g]				
Piston Ø	32	40	50	63
DNCI-...				
Product weight with 0 mm stroke	521	853	1,319	1,914
Additional weight per 10 mm stroke	30	44	62	71
Moving load with 0 mm stroke	95	175	316	383
Additional weight per 10 mm stroke	8	14	23	23
DNCI-...-S2 – through piston rod				
Product weight with 0 mm stroke	586	981	1,553	2,165
Additional weight per 10 mm stroke	39	60	87	96
Moving mass with 0 mm stroke	155	164	297	364
Additional weight per 10 mm stroke	17	30	48	48
DNCI-...-K8 – additional weight with piston rod extension				
Additional weight per 10 mm stroke	8	14	23	23
DNCI-...-KP – additional weight with clamping unit				
Product weight	234	394	700	1,147
DNCI-...-FENG – additional weight with guide unit				
Product weight with 0 mm stroke	1,530	2,370	4,030	5,410
Additional weight per 10 mm stroke	18	32	50	62

Materials

Sectional view

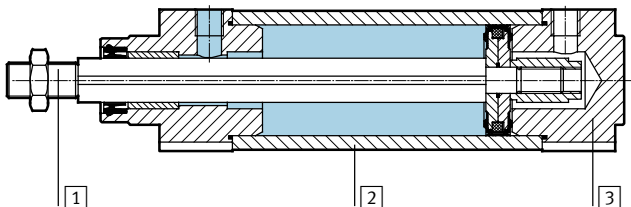

Standard cylinder	
1	Piston rod High-alloy steel
2	Cylinder barrel Anodised aluminum
3	Bearing/end caps Die-cast aluminum
-	Dynamic seals Polyurethane TPE-U
-	Static seals Nitrile rubber
Note on materials RoHS-compliant	
Displacement encoder	
-	Sensor housing Polyacetal
-	Cable sheath Polyurethane
-	Plug housing Polybutylene terephthalate
-	Mounting plate Polyacetal
-	Screws for mounting plate Steel

Standard cylinders DNCI, with measured-value transducer DADE

Technical data

Torques and lateral forces

The piston rod must not absorb any torque. We therefore recommend using an external guide unit FENG-KF with the drive DNCI. The guide unit is supplied attached.

The permissible static and dynamic characteristic load values with and without attached guide as well as with regard to the technical data of the variants (S2, S8, S9)

→ Internet: dnc

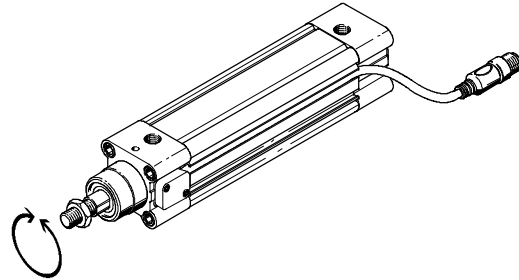

Mounting conditions

The following conditions must be observed, when mounting a drive A with magnet (for position sensing) next to a standard cylinder DNCI:

- X Minimum distance between the drives
- Y Offset between the drives on the bearing cap

Parallel assembly

The drives can be assembled directly next to one another if the offset $Y = 0$ mm.

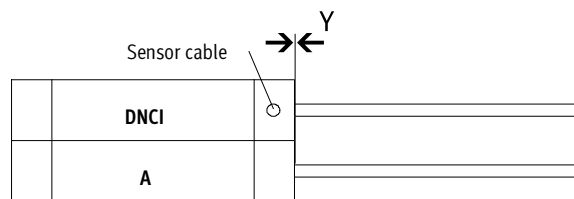

Off-set assembly, cable outlet between the drives

A distance of $X > 70$ mm must be observed, if the offset is $Y > 0$ mm and the cable outlet is between the drives.

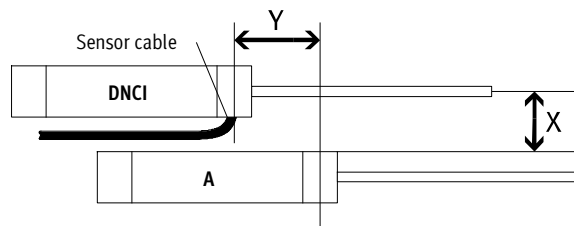

Off-set assembly, cable outlet upwards or downwards

A distance of $X > 60$ mm must be observed, if the offset is $Y > 0$ mm and the cable outlet is up or down.

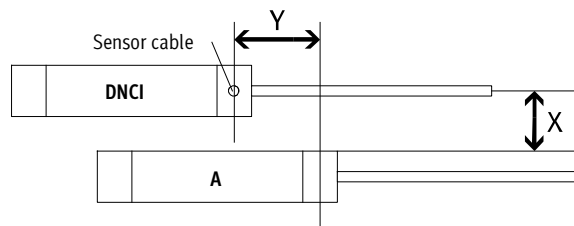

Standard cylinders DNCL, with measured-value transducer DADE

Technical data

FESTO

Dimensions

Download CAD data → www.festo.com

Basic design

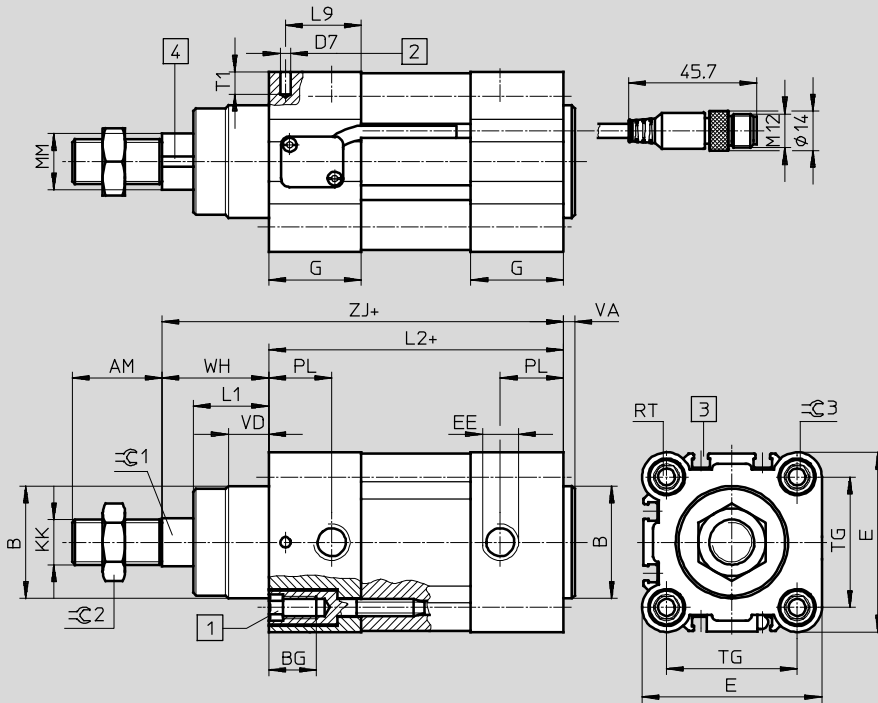

- 1 Socket head screw with female thread for mounting attachments
- 2 Hole for securing the earthing for self-tapping M4 screw according to DIN 7500
- 3 Sensor slot for proximity sensor SME/SMT-8
- 4 Magnetic measuring band

+ = plus stroke length
++ = plus 2x stroke length

S2 – Through piston rod

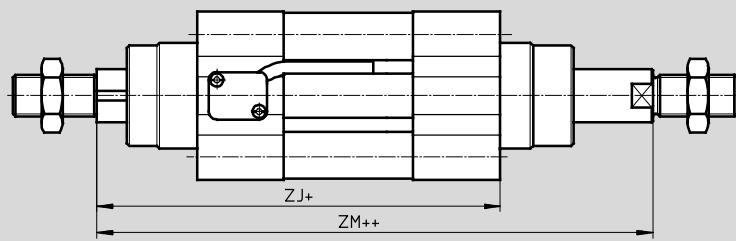

+ = plus stroke length
++ = plus 2x stroke length

S2/KP – Through piston rod with clamping unit

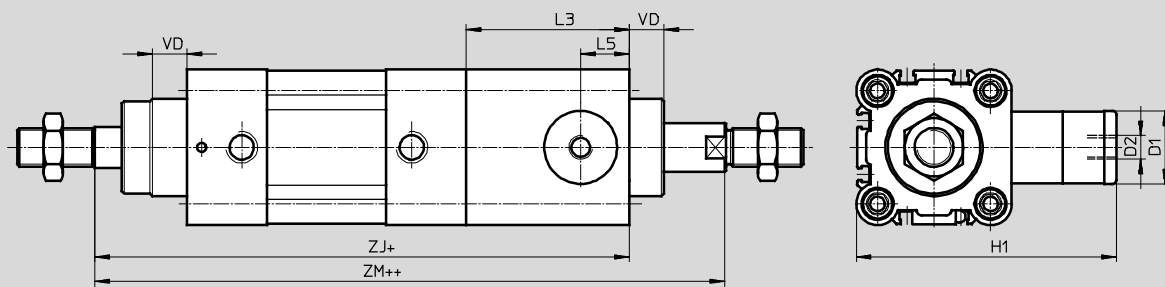

K8 – Extended piston rod

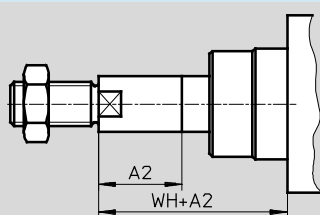

Standard cylinders DNCI, with measured-value transducer DADE

Technical data

∅ [mm]	AM	A2 max.	B ∅ d11	BG	D1 ∅ f9	D2	D7 ∅	E	EE	G	H1
32	22	500	30	16	20	M5	3.7	45	G $\frac{1}{8}$	28	67
40	24	500	35	16	24	G $\frac{1}{8}$	3.7	54	G $\frac{1}{4}$	33	88
50	32	500	40	17	30	G $\frac{1}{8}$	3.7	64	G $\frac{1}{4}$	33	107
63	32	500	45	17	38	G $\frac{1}{8}$	3.7	75	G $\frac{3}{8}$	40.5	123

∅ [mm]	KK	L1	L2	L3	L5	L9	MM ∅ f8	PL	RT	T1	TG
32	M10x1.25	18	94	45	14	22.5	12	15.6	M6	8	32.5
40	M12x1.25	21.3	105	53	16	27	16	14	M6	8	38
50	M16x1.5	26.8	106	67	20	27	20	14	M8	8	46.5
63	M16x1.5	27	121	76	24	33	20	17	M8	8	56.5

∅ [mm]	VA	VD	WH	ZJ		ZM		≈C1	≈C2	≈C3
					KP		KP			
32	4	10	26	120	165	148	193	10	16	6
40	4	10.8	30	135	188	167	220	13	18	6
50	4	14.3	37	143	210	183	250	17	24	8
63	4	14.5	37	158	234	199	275	17	24	8

Standard cylinders DNCl, with measured-value transducer DADE

Technical data

Dimensions

Download CAD data → www.festo.com

Guide unit FENG-KF

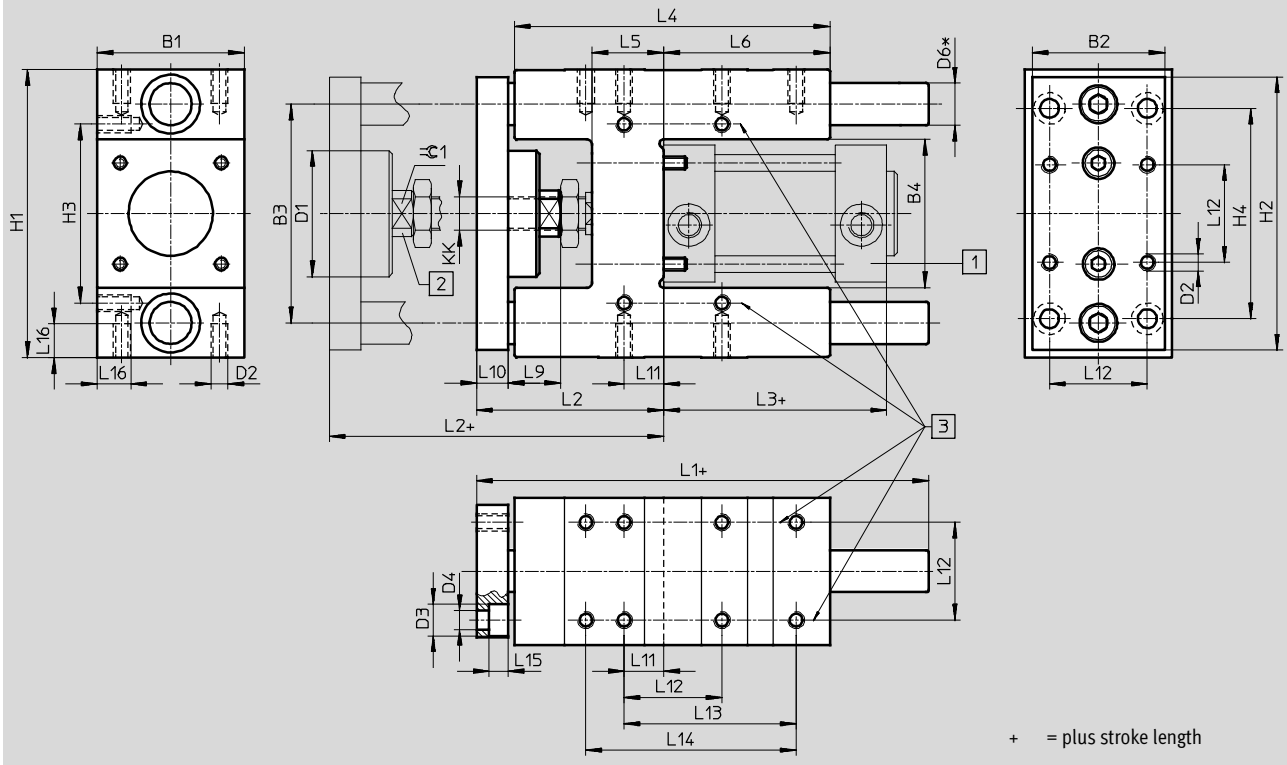

Standard cylinders DNCl, with measured-value transducer DADE

Technical data

For Ø	B1	B2	B3	B4	D1	D2	D3	D4	D6	H1
[mm]	-0.3		±0.2	±0.3	Ø		Ø	Ø	Ø h6	
32	50	45	74	50.5	44	M6	11	6.6	12	97 _{-0.4}
40	58	54	87	58.5	44	M6	11	6.6	16	115 _{-0.4}
50	70	63	104	70.5	60	M8	15	9	20	137 _{-0.5}
63	85	80	119	85.5	60	M8	15	9	20	152 _{-0.5}

For Ø	H2	H3	H4	KK	L1	L2	L3	L4	L5	L6
[mm]		±0.2	±0.2							
32	90	61	78	M10x1.25	155	67 ₊₅	94	125	24	76
40	110	69	84	M12x1.25	170	75 ₊₅	105	140	28	81
50	130	85	100	M16x1	188	89 ₊₁₀	106	150	34	79
63	145	100	105	M16x1	220	89 ₊₁₀	121	182	34	111

For Ø	L9	L10	L11	L12	L13	L14	L15	L16	≈C1
[mm]				±0.2	±0.2	±0.2			
32	20	12	4.3	32.5	70.3	78	6.5	12	15
40	22	12	11	38	84	-	6.5	14	15
50	25	15	18.8	46.5	81.8	100	9	16	19
63	25	15	15.3	56.5	105	-	9	16	19

Standard cylinders DNCI, with measured-value transducer DADE



Ordering data – Modular products

Ordering table							
Piston Ø	32	40	50	63	Condi- tions	Code	Enter code
M Module No.	535411	535412	535413	535414			
Function	Standard cylinder with integrated displacement encoder, non-rotating piston rod					DNCI	DNCI
Piston Ø [mm]	32	40	50	63		-...	
Stroke [mm]	10 ... 2,000					-...	
Cushioning	Elastic cushioning rings/plates at both ends					-P	-P
↓ Position sensing	For proximity sensor					-A	-A

Transfer order code

Standard cylinders DNCI, with measured-value transducer DADE

Ordering data – Modular product

Ordering table								
Piston Ø	32	40	50	63	Condi- tions	Code	Enter code	
0	Piston rod type				Through piston rod		-S2	
	Piston rod extended at [mm] front				1 ... 500	2	-...K8	
	Clamping unit				Attached	3	-KP	
	Guide				Guide unit with ball bearing guide on the sensor head side	4	-FENG	
	Measured-value transducer				Output 0 ... 10 V		-MU	
							-MI	
	Measuring head				No measuring head	5	-MS	

- 2 **K8** The piston rod is only extended at the front (side closest to the measuring head) in combination with piston rod type S2.
- 3 **KP** Can only be combined with piston rod type S2
- 4 **FENG** Maximum stroke length 500 mm

 Note

5 In the case of repairs, the standard cylinder can be ordered without a measuring head (→ code MS). The existing measuring head can then be installed in the new standard cylinder (→ operating instructions for DNCI).

Transfer order code

- [] - [] - [] - [] - [] - []

Standard cylinders DNCl, with measured-value transducer DADE

Technical data

Measured-value transducer

DADE-MVC-010

DADE-MVC-420

(Order code MU, MI)

The measured-value transducer converts sensor signals from the standard cylinder DNCl into a voltage signal of 0 ... 10 V or a current signal of 4 ... 20 mA. These signals can be evaluated by a PLC with an appropriate signal input.

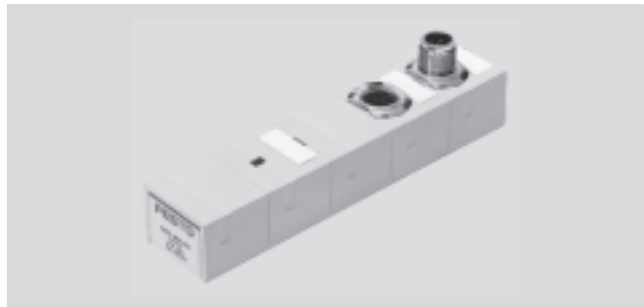

General technical data		
Type of mounting	Via through-hole	
Mounting position	Any	
Repetition accuracy in relation to effective stroke	≤ 400	±0.1 mm
	≤ 750	±0.2 mm
	≤ 1200	±0.3 mm
	≤ 1600	±0.4 mm
	≤ 2000	±0.5 mm
Protection against short circuit	Yes	
Protection against incorrect polarity	Yes	
Diagnostic function	Display via LED	

General electrical data		
Analogue output	[V]	0 ... 10 (according to EN 61131-2)
	[mA]	4 ... 20 (according to EN 61131-2)
Nominal operating voltage	[V DC]	24 ±25%
Residual ripple	[%]	4 (at 50 Hz)
Current consumption at nominal operating voltage	[mA]	20 ... 30
Switching logic at outputs	PNP	
Switching logic at inputs	PNP	
Debounce time at inputs	[ms]	3
Linearity error FS	0.2%	

Operating and environmental conditions		
Ambient temperature	[°C]	0 ... 55
Protection class	IP65	
Relative air humidity	95% non-condensing	
CE marking (see declaration of conformity)	To EU EMC Directive	
Corrosion resistance class CRC ¹⁾	1	
Product weight	[g]	128
Note on material for housing	Polybutylene terephthalate	

1) Corrosion resistance class 1 according to Festo standard 940 070
 Components subject to low corrosion stress. Transport and storage protection. Parts that do not have primarily decorative surface requirements, e.g. in internal areas that are not visible or behind covers.

Standard cylinders DNCI, with measured-value transducer DADE

Technical data

FESTO

Dimensions Download CAD data → www.festo.com

1 PLC interface:
8-pin M12, male

2 Measuring system interface:
8-pin M12, female

Pin allocation

PLC interface

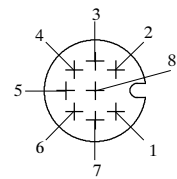

Measuring system interface

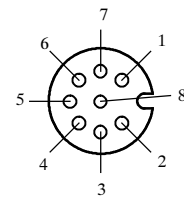

Pin	Function	Cable colour
1	24V	White
2	Analogue measurement signal	Brown
3	Reference output	Green
4	0 V measurement signal	Yellow
5	Reference input	Grey
6	Calibration input	Pink
7	Ready output	Blue
8	0 V power supply and inputs/ outputs	Red

Pin	Function
1	Ub
2	0 V
3	Signal sine +
4	Signal sine -
5	Signal cosine -
6	Signal cosine +
7	Screening / earth
8	-

Ordering data

		Description	Part no.	Type
Measured-value transducer				
	With voltage signal	0 ... 10 V	542 117	DADE-MVC-010
	With current signal	4 ... 20 mA	542 118	DADE-MVC-420
Accessories Technical data → Internet: sim				
	Connecting cable	PLC connecting cable (length 2 m)	525 616	SIM-M12-8GD-2-PU
		PLC connecting cable (length 5 m)	525 618	SIM-M12-8GD-5-PU