

Guided drives DGRF-C, Clean Design

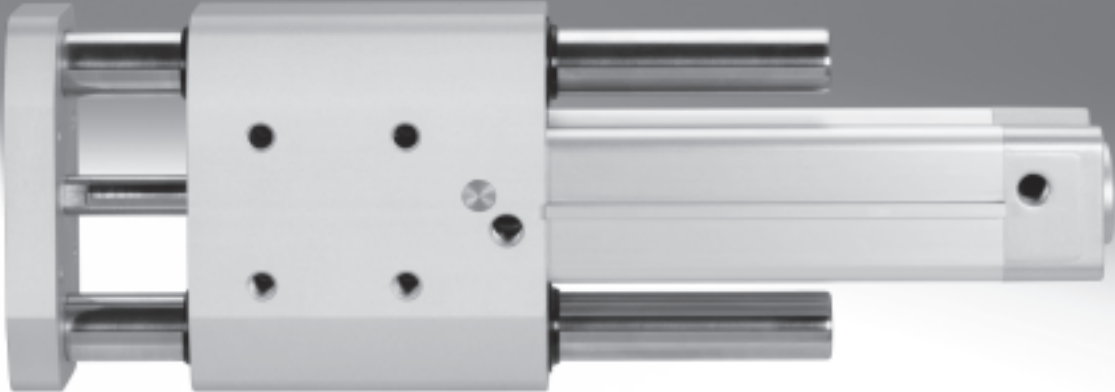

Guided drives DGRF-C, Clean Design

Features and Product range overview

At a glance

- The guided drive is used wherever hygiene, ease of cleaning and resistance are important, predominantly in dry and splash zones in the food and packaging industry.
- Corrosion-resistant in harsh environmental conditions
- Easy-to-clean design
- NSF-H1 compliant lubrication
- Resistant to conventional cleaning agents
- For hygiene reasons, the threads on the end caps should be sealed with suitable blanking screws
- With a dry-running seal (A3), the cylinder will continue to function reliably even if the lubricant has been washed away due to frequent cleaning.

Areas of application:

- Bottling systems in the beverage industry
 - Labelling and palletising machines
- Milk processing
 - Filling ice cream and yoghurt containers, etc.
- Meat processing
- Confectionery production
- Bakery production
- Packaging industry
 - Food, pharmaceuticals, cosmetics, chemicals, beverages and tobacco

Mounting options

Underneath

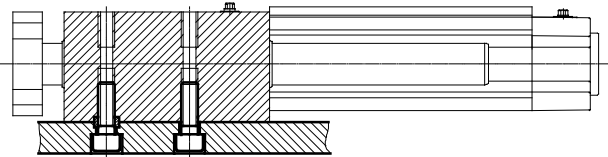

On top

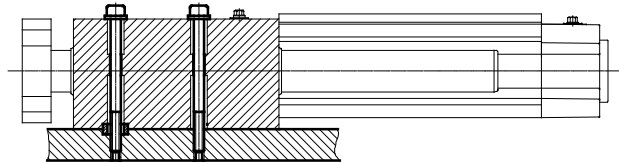

On the yoke plate

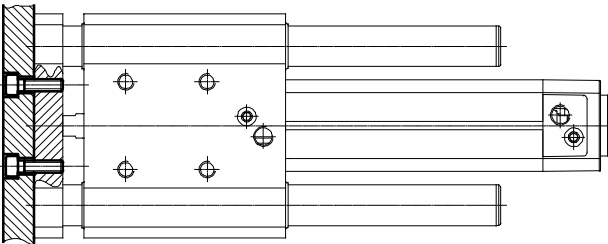

Product range overview

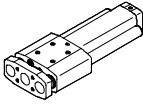
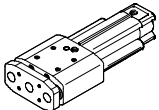
Function	Type	Piston Ø	Stroke	Cushioning			Position sensing	Mounting rail	Unlubricated operation
				P	PPV	PPS	A	R	A3
Double-acting	DGRF-C-GF								
		20, 25	10 ... 400	■	-	-	-	-	■
		32	10 ... 400	■	■	■	■	■	■
		40, 50, 63	10 ... 400	-	■	■	■	■	■

Guided drives DGRF-C, Clean Design

Peripherals overview

FESTO

Piston \varnothing 20, 25

Piston \varnothing 32, 40, 50, 63

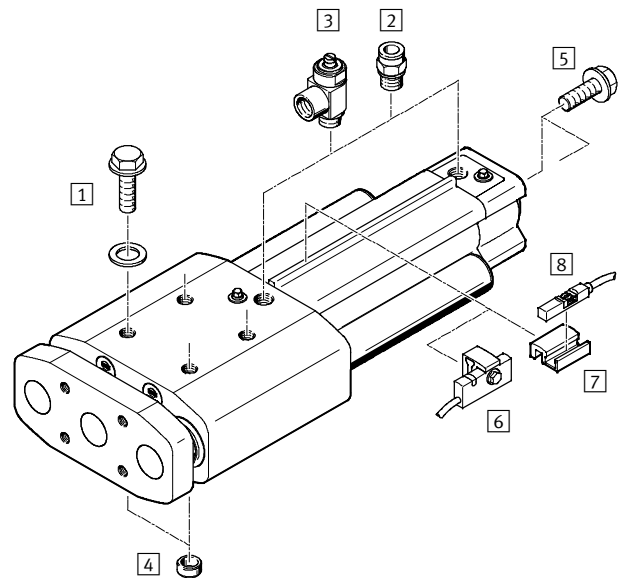
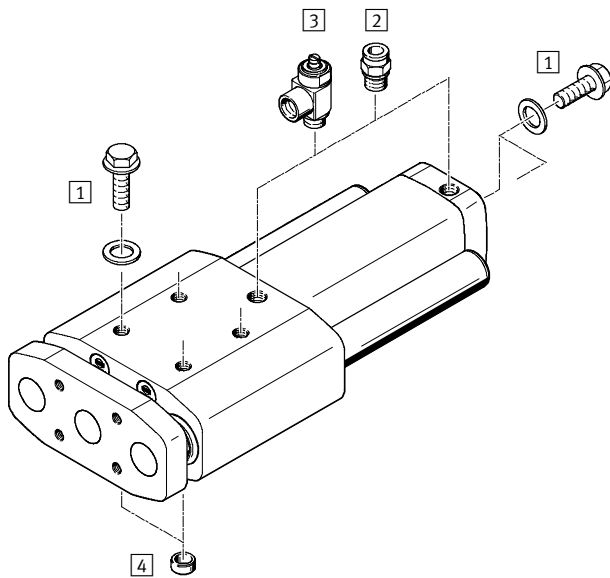

Accessories	Brief description	DGRF-...-			→ Page/ Internet
		P	PPV	PPS	
1 Plug screw DAMD	<ul style="list-style-type: none"> For sealing unused mounting threads The cover plate is included with the screw The screws are not included with the drive 	■	■	■	15
2 Push-in fitting NPQH/CRQS/CRQSL/NPQP	For connecting overall toleranced tubing	■	■	■	13
3 One-way flow control valve CRGRLA/GRLA-F	For regulating speed	■	■	■	14
4 Centring sleeve ZBH	<ul style="list-style-type: none"> For centring the guided drive Two centring sleeves are included in the scope of delivery 	■	■	■	15
5 Plug screw DAMD	<ul style="list-style-type: none"> For sealing unused mounting threads The screws are not included with the drive 	■	■	■	15
6 Proximity sensor SMT-C1	<ul style="list-style-type: none"> For sensing the piston rod position Proximity sensor is mounted on the sensor mounting rail 	■	■	■	12
7 Mounting kit SMB-8-C	<ul style="list-style-type: none"> For mounting the proximity sensor CRSMT-8M Mounting kit is mounted on the sensor mounting rail 	-	-	■	12
8 Proximity sensor CRSMT-8M	For sensing the piston rod position	-	-	■	12

Guided drives DGRF-C, Clean Design

Type codes

		DGRF	-	C	-	GF	-	32	-	200	-	PPV	-	A	-	R	-	A3	
Type																			
Double-acting																			
DGRF	Guided drive																		
Design																			
C	Easy-to-clean design																		
Guide																			
GF	Plain-bearing guide																		
Piston Ø [mm]																			
Stroke [mm]																			
Cushioning																			
P	Elastic cushioning rings at both ends																		
PPV	Pneumatic cushioning, adjustable at both ends																		
PPS	Pneumatic cushioning, self-adjusting at both ends																		
Position sensing																			
A	Via proximity sensor																		
Sensor mounting, external																			
R	Mounting rail for proximity sensor																		
Wiper seal material																			
-	Standard																		
A3	Suitable for unlubricated operation																		

Guided drives DGRF-C, Clean Design

Technical data

Function

P cushioning

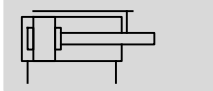

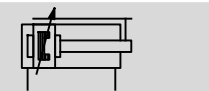

PPV cushioning

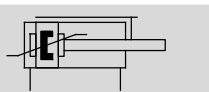

PPS cushioning



-  Diameter
20 ... 63 mm
-  Stroke length
10 ... 400 mm
-  www.festo.com



General technical data						
Piston \varnothing	20	25	32	40	50	63
Pneumatic connection	M5	M5	G $\frac{1}{8}$	G $\frac{1}{4}$	G $\frac{1}{4}$	G $\frac{3}{8}$
Mode of operation	Double-acting					
Design	Guide					
	Guide rods with yoke					
Guide	Plain-bearing guide					
Cushioning	P	Elastic cushioning rings at both ends			-	
	PPV	-			Pneumatic cushioning, adjustable at both ends	
	PPS	-			Pneumatic cushioning, self-adjusting at both ends	
Cushioning length	[mm]	-	20	20	22	22
Position sensing		-	Via proximity sensor			
Type of mounting	Via through-hole					
	Via female thread					
Mounting position	Any					
Torsional backlash ¹⁾	[°]	0.13	0.11	0.10	0.09	0.07

1) Retracted state, without load

Operating and environmental conditions						
Piston \varnothing	20	25	32	40	50	63
Variant			P	PPV/PPS		
Operating medium	Compressed air to ISO 8573-1:2010 [7:4:4]					
Note on operating/pilot medium	Lubricated operation possible (in which case lubricated operation will always be required)					
Operating pressure	[bar]	2.5 ... 10	2 ... 10	2 ... 12	2 ... 12	1.5 ... 12
	A3 [bar]	2 ... 10		2 ... 12	1.5 ... 12	
Ambient temperature	[°C]	-20 ... +80				
Suitable for use in the food industry	As per manufacturer's declaration (→ Support Portal)					
Corrosion resistance class CRC ¹⁾	3					

1) Corrosion resistance class 3 according to Festo standard 940 070
Components subject to high corrosion stress. Externally visible parts with primarily functional surface requirements which are in direct contact with a normal industrial environment or media such as solvents and cleaning agents.

Guided drives DGRF-C, Clean Design

Technical data

Forces [N] and impact energy [J]						
Piston Ø	20	25	32	40	50	63
Theoretical force at 6 bar, advancing	189	295	483	754	1,178	1,870
Theoretical force at 6 bar, retracting	141	247	415	633	990	1,682
Max. impact energy in the end positions with P cushioning	0.2	0.3	0.4	-	-	-

Permissible impact velocity

$$v_{perm.} = \sqrt{\frac{2 \times E_{perm.}}{m_{intrinsic} + m_{Load}}}$$

$v_{perm.}$ Permissible impact velocity
 $E_{perm.}$ Maximum impact energy
 $m_{intrinsic}$ Moving mass (drive)
 m_{Load} Moving payload

 Note
 These specifications represent the maximum values that can be achieved. Note the maximum permissible impact energy.

Maximum permissible load:

$$m_{Load} = \frac{2 \times E_{perm.}}{v^2} - m_{intrinsic}$$

Weight [g]							
Piston Ø	20	25	32		40	50	63
			P	PPV/PPS			
Product weight with 0 mm stroke	885	1,199	2,090	2,305	3,000	4,800	6,405
Additional weight per 10 mm stroke	52	55	80	78	90	140	143
Moving mass with 0 mm stroke	417	486	902	904	1,065	1,792	2,114
Moving mass per 10 mm stroke	38	38	58	58	65	102	102

Materials

Sectional view

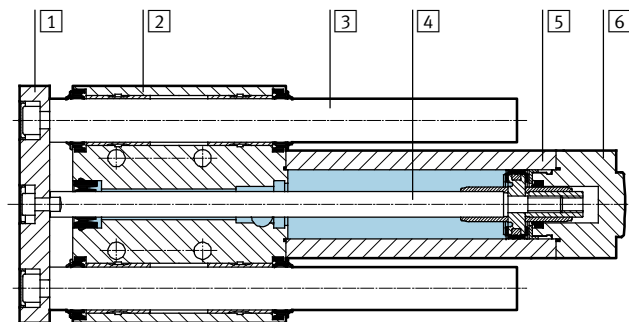

Guided drive	
1 Yoke plate	Anodised wrought aluminium alloy
2 Housing	Anodised wrought aluminium alloy
3 Guide rod	High-alloy stainless steel
4 Piston rod	High-alloy stainless steel
5 Cylinder barrel	Anodised wrought aluminium alloy
6 Cover	
DGRF-...-20/-25/-32-P	Anodised wrought aluminium alloy
DGRF-...-32-PPV/PPS	Die-cast aluminium, coated
DGRF-...-40/-50/-63	Die-cast aluminium, coated
- Seal	
DGRF-...	Polyurethane elastomer
DGRF-...-A3	Polyethylene
Note on materials	RoHS-compliant

Guided drives DGRF-C, Clean Design

Technical data

Max. payload F as a function of stroke l

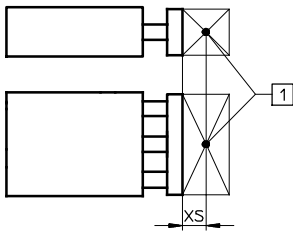

1 Centre of gravity of load

- Load data are based on a distance from the centre of gravity of $X_S = 50\text{ mm}$
- Load data for larger distances on request

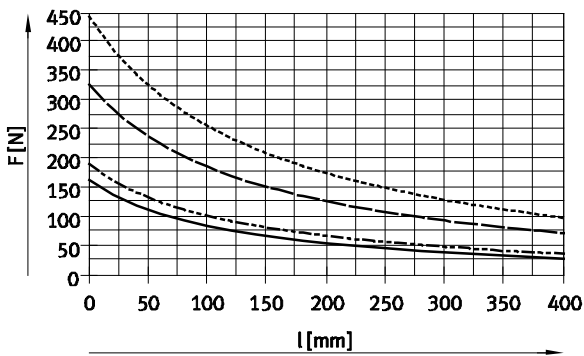

- Ø 20
- - - Ø 25
- · - · Ø 32/40
- · · · · Ø 50/63

Max. torque load M as a function of stroke l

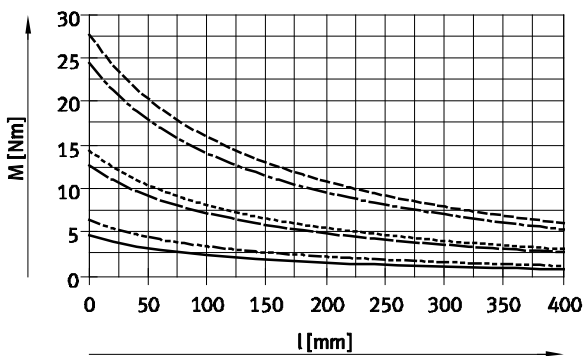
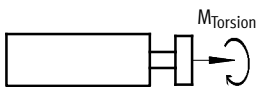

- Ø 20
- - - Ø 25
- · - · Ø 32
- · · · · Ø 40
- - - - - Ø 50
- - - - - Ø 63

Guided drives DGRF-C, Clean Design

Technical data

FESTO

Deflection of piston rod

Deflection f_1 due to bearing clearance as a function of stroke l

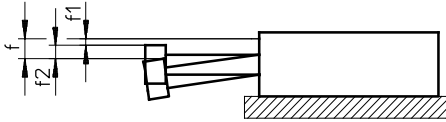

$$f = f_1 + f_2$$

f = Total deflection of piston rod

f_1 = Deflection due to bearing clearance

f_2 = Deflection due to lateral force

Deflection f_1 ,
due to bearing clearance as a function of stroke l

Deflection f_2 ,
due to useful load F and rigidity c as a function of stroke l

$$f_2 = \frac{F}{c}$$

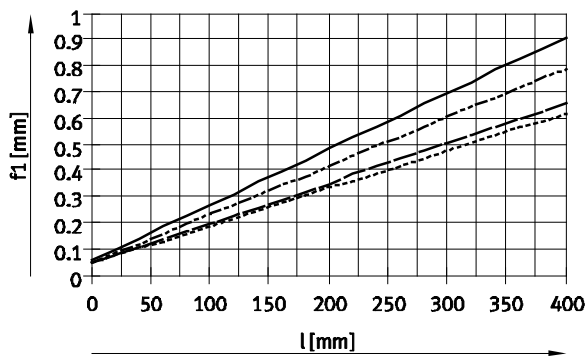

- $\varnothing 20$
- - - $\varnothing 25$
- $\varnothing 32/40$
- - - $\varnothing 50/63$

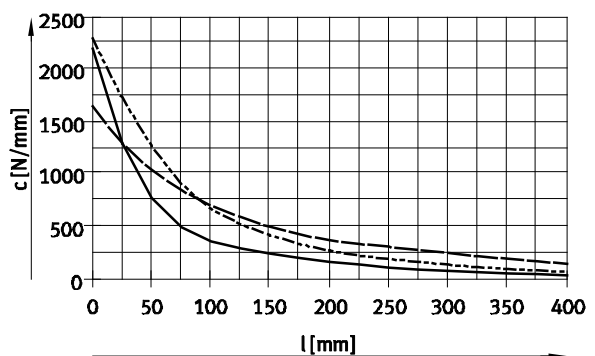

- $\varnothing 20/25$
- - - $\varnothing 32/40$
- - - $\varnothing 50/63$

End-position sensing

With proximity sensor SMT-C1

A minimum stroke is required to be able to sense both end positions at the cylinder.

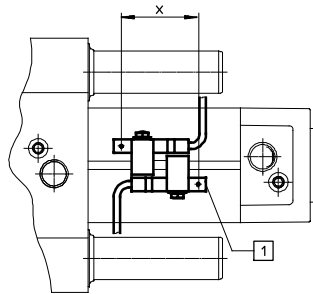

- 1 Position of the proximity sensor within the housing.

Piston \varnothing	32	40	50	63
Minimum stroke x [mm]	35	35	35	30

With mounting kit SMB-8-C and proximity sensor CRSMT-8M

A minimum stroke is required to be able to sense both end positions at the cylinder.

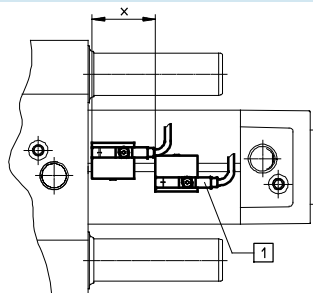

- 1 Position of the proximity sensor within the housing.

Piston \varnothing	32	40	50	63
Minimum stroke x [mm]	30	30	30	30

Guided drives DGRF-C, Clean Design

Technical data

Dimensions

Download CAD data → www.festo.com

DGRF-...-PPV – pneumatic cushioning, adjustable at both ends

DGRF-...-PPS – pneumatic cushioning, self-adjusting at both ends

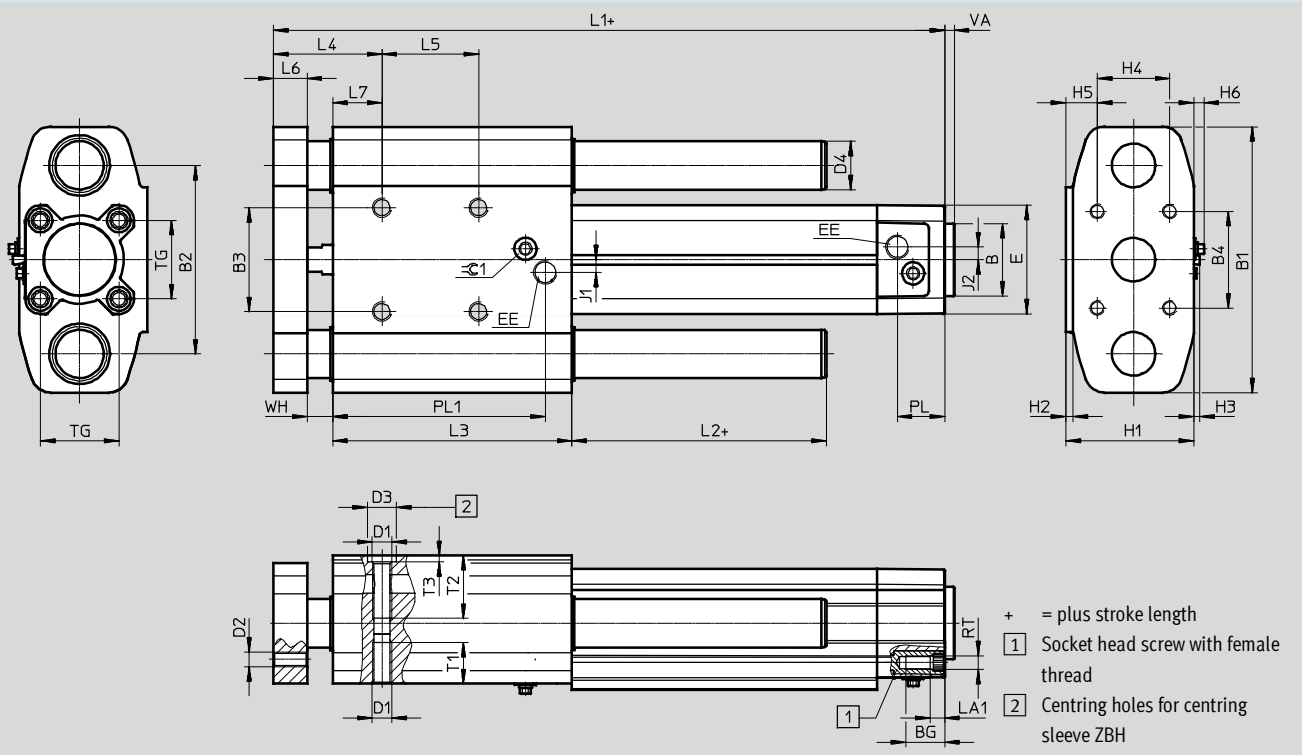

∅	B	BG	B1	B2	B3 ²⁾	B4	D1	D2	D3 ³⁾	D4	E	EE	H1	H2
[mm]	∅ d11								∅ H7	∅				
32	30	16	110	78	43	40	M8	M6	12	20	45	G $\frac{1}{8}$	53	3
40	35	16	120	88	51	50	M8	M6	12	20	54	G $\frac{1}{4}$	61	3
50	40	17	148	110	64	60	M8	M8	12	25	64	G $\frac{1}{4}$	73	3
63	45	17	162	125	80	80	M10	M8	12	25	75	G $\frac{3}{8}$	84	3

∅	H3 ¹⁾	H4	H5	H6	J1	J2	L1	L2	L3	L4	L5
[mm]											
32	2.5	30	13	5.6	5.3	5.3	177.6 +1.9/-1.2	7.4	99	45 +1.5/-1.1	40
40	3	30	17	5.6	4	4	183.5 +1.9/-1.3	7.5	99	45 +1.5/-1.1	40
50	2	40	18	7.5	5.5	5.5	193.5 +1.7/-1.3	7.7	105	50 +1.3/-1.2	40
63	2	40	23.5	9.3	6.3	6.3	207.3 +1.7/-1.3	7.5	105	50 +1.3/-1.2	40

∅	L6	L7	LA1	PL	PL1	RT	T1	T2	T3	TG	VA	WH	∅ 1
[mm]													
32	14	20.4	5.6	19.5	88	M6	17	26	2.6	32.5	4	10.6 +1/-0.9	4
40	14	20.5	5.6	22.5	83	M6	17	26	2.6	38	4	10.5 ±1/-1	4
50	16	22.7	6.1	22.5	89	M8	17	20	2.6	46.5	4	11.3 +0.8/-1	4
63	20	18.5	6.1	27.5	88	M8	17	24	2.6	56.5	4	11.5 +0.8/-1	4

1) Only in combination with sensor mounting rail (DGRF-...-R)

2) Tolerance between centring holes ±0.02 mm

3) Two centring sleeves included in the scope of delivery

Guided drives DGRF-C, Clean Design

Ordering data – Modular products

Ordering table									
Size	20	25	32	40	50	63	Condi- tions	Code	Entry code
M Module No.	562216	562217	563366	562219	562220	562221			
Function	Guided drive							DGRF	DGRF
Product version	Easy-to-clean design							-C	-C
Guide	Plain-bearing guide							-GF	-GF
Piston Ø [mm]	20	25	32	40	50	63		-...	
Stroke [mm]	10 ... 400							-...	
Cushioning	Elastic cushioning rings at both ends							-P	
				Pneumatic cushioning, adjustable at both ends				-PPV	
				Pneumatic cushioning, self-adjusting at both ends				-PPS	
Position sensing				Via proximity sensor			<input type="checkbox"/>	A	
Sensor mounting, external				Mounting rail for proximity sensor			<input type="checkbox"/>	-R	
O Wiper seal variant	Standard								
	For unlubricated operation							-A3	

A, R Always included with piston Ø 32 ... 63.

Transfer order code

Guided drives DGRF-C, Clean Design

Accessories

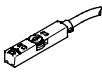

With DGRF-...-PPS permissible:

Ordering data – Proximity sensor for T-slot, magneto-resistive						Technical data → Internet: smt
	Type of mounting	Switching output	Electrical connection	Cable length [m]	Part No.	Type
N/O contact						
	Insertable in the slot from above, flush with the mounting kit	PNP	Cable, 3-wire	5.0	574380	CRSMT-8M-PS-24V-K-5,0-OE
			Cable, 3-wire	10.0	574381	CRSMT-8M-PS-24V-K-10,0-OE
			Plug M8x1, 3-pin	0.3	574383	CRSMT-8M-PS-24V-K-0,3-M8D
			Plug M12x1, 3-pin	0.3	574382	CRSMT-8M-PS-24V-K-0,3-M12

Ordering data – Mounting kit			
	Description	Part No.	Type
	For mounting the proximity sensor CRSMT-8M on the mounting rail	1806790	SMB-8-C

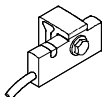
With DGRF-...-P/-PPV/-PPS permissible:





Ordering data – Proximity sensor for T-slot, magneto-resistive						Technical data → Internet: smt
	Type of mounting	Switching output	Electrical connection	Cable length [m]	Part No.	Type
N/O contact						
	Is mounted on the mounting rail	PNP	Cable, 3-wire	5.0	571339	SMT-C1-PS-24V-K-5,0-OE
			Plug M8x1, 3-pin	0.3	571342	SMT-C1-PS-24V-K-0,3-M8D
			Plug M12x1, 3-pin	0.3	571341	SMT-C1-PS-24V-K-0,3-M12

Ordering data – Connecting cables for SMT-C1-...					Technical data → Internet: nebu
	Electrical connection, left	Electrical connection, right	Cable length [m]	Part No.	Type
	Straight socket, M8x1, 3-pin	Cable, open end, 3-wire	2.5	541333	NEBU-M8G3-K-2.5-LE3
			5	541334	NEBU-M8G3-K-5-LE3
	Straight socket, M12x1, 5-pin	Cable, open end, 3-wire	2.5	541363	NEBU-M12G5-K-2.5-LE3
			5	541364	NEBU-M12G5-K-5-LE3
	Angled socket, M8x1, 3-pin	Cable, open end, 3-wire	2.5	541338	NEBU-M8W3-K-2.5-LE3
			5	541341	NEBU-M8W3-K-5-LE3
	Angled socket, M12x1, 5-pin	Cable, open end, 3-wire	2.5	541367	NEBU-M12W5-K-2.5-LE3
			5	541370	NEBU-M12W5-K-5-LE3

Guided drives DGRF-C, Clean Design

Accessories

FESTO

Ordering data – Push-in fittings					Technical data → Internet: quick star					
	Connection		Material	Weight [g]	Part No.	Type	PU ²⁾			
	Thread	Tubing O.D. Ø								
With external hexagon										
	M5	4	Nickel- and chrome-plated brass	–	578334	NPQH-D-M5-Q4-P10	10			
		6		–	578335	NPQH-D-M5-Q6-P10				
	G1/8	4		6.1	578338	NPQH-D-G18-Q4-P10				
		6		9	578339	NPQH-D-G18-Q6-P10				
		8		11.4	578340	NPQH-D-G18-Q8-P10				
	G1/4	6		12.7	578341	NPQH-D-G14-Q6-P10				
		8		13.6	578342	NPQH-D-G14-Q8-P10				
		10		17.4	578343	NPQH-D-G14-Q10-P10				
	G3/8	8		20.1	578345	NPQH-D-G38-Q8-P10				
		10		22.6	578346	NPQH-D-G38-Q10-P10				
		12		28.9	578347	NPQH-D-G38-Q12-P10				
		M5		4	Stainless steel	6.0		162860	CRQS-M5-4 ¹⁾	1
6			8.4	162861		CRQS-M5-6 ¹⁾				
R1/8		4	8.7	132643		CRQS-1/8-4				
		6	9.9	162862		CRQS-1/8-6				
		8	12	162863		CRQS-1/8-8				
R1/4		6	18	132644		CRQS-1/4-6				
		8	18	162864		CRQS-1/4-8				
		10	22	162865		CRQS-1/4-10				
R3/8		10	29	162866		CRQS-3/8-10				
		12	37	162867		CRQS-3/8-12				
		R1/8	4	Polypropylene		2.5	133041	NPQP-D-R18-Q4-FD-P10	10	
			6			3.0	133043	NPQP-D-R18-Q6-FD-P10		
	8		4.5		133045	NPQP-D-R18-Q8-FD-P10				
	R1/4	6	3.5		133044	NPQP-D-R14-Q6-FD-P10				
		8	4.5		133046	NPQP-D-R14-Q8-FD-P10				
		10	7.0		133047	NPQP-D-R14-Q10-FD-P10				
	R3/8	10	8.0		133048	NPQP-D-R38-Q10-FD-P10				
		12	12.0		133049	NPQP-D-R38-Q12-FD-P10				
	With internal hexagon									
		M5	4		Nickel- and chrome-plated brass	4.6	578370	NPQH-DK-M5-Q4-P10		10
6			8.6	578371		NPQH-DK-M5-Q6-P10				
G1/8		4	–	578374		NPQH-DK-G18-Q4-P10				
		6	–	578375		NPQH-DK-G18-Q6-P10				
		8	–	578376		NPQH-DK-G18-Q8-P10				
G1/4		8	–	578377		NPQH-DK-G14-Q8-P10				
		10	–	578378		NPQH-DK-G14-Q10-P10				
G3/8		12	–	578379		NPQH-DK-G38-Q12-P10				
	M5	4	Stainless steel	5	132328	CRQS-M5-4- ¹⁾	1			
		6		7.7	132329	CRQS-M5-6- ¹⁾				
	R1/8	6		8.4	132330	CRQS-1/8-6-I				
		8		12	132331	CRQS-1/8-8-I				
	R1/4	8		15	132332	CRQS-1/4-8-I				
		10		21	132333	CRQS-1/4-10-I				
	R3/8	10		24	132334	CRQS-3/8-10-I				



1) With sealing ring

2) Packaging unit quantity



Guided drives DGRF-C, Clean Design

Accessories

FESTO

Ordering data – Push-in L-fittings					Technical data → Internet: quick star					
	Connection		Material	Weight [g]	Part No.	Type	PU ²⁾			
	Thread	Tubing O.D. Ø								
With external hexagon										
	M5	4	Nickel- and chrome-plated brass	8.8	578276	NPQH-L-M5-Q4-P10	10			
		6		11.9	578277	NPQH-L-M5-Q6-P10				
	G1/8	4		15.7	578280	NPQH-L-G18-Q4-P10				
		6		18.5	578281	NPQH-L-G18-Q6-P10				
		8		22	578282	NPQH-L-G18-Q8-P10				
	G1/4	6		21.8	578283	NPQH-L-G14-Q6-P10				
		8		25.3	578284	NPQH-L-G14-Q8-P10				
		10		34	578285	NPQH-L-G14-Q10-P10				
		12		58.5	578286	NPQH-L-G14-Q12-P10				
	G3/8	8		37.7	578287	NPQH-L-G38-Q8-P10				
		10		39.2	578288	NPQH-L-G38-Q10-P10				
		12		56.1	578289	NPQH-L-G38-Q12-P10				
		M5		4	Stainless steel	12		162870	CRQSL-M5-4 ¹⁾	1
				6		18		162871	CRQSL-M5-6 ¹⁾	
		R1/8		4		14		132598	CRQSL-1/8-4	
6			19	162872		CRQSL-1/8-6				
8			26	162873		CRQSL-1/8-8				
R1/4		6	26	132599		CRQSL-1/4-6				
		8	30	162874		CRQSL-1/4-8				
		10	42	162875		CRQSL-1/4-10				
R3/8		10	49	162876		CRQSL-3/8-10				
		12	65	162877		CRQSL-3/8-12				
		R1/8	4	Polypropylene		4.0	133051	NPQP-L-R18-Q4-FD-P10	10	
			6			5.0	133053	NPQP-L-R18-Q6-FD-P10		
	8		7.0		133055	NPQP-L-R18-Q8-FD-P10				
	R1/4	6	5.5		133054	NPQP-L-R14-Q6-FD-P10				
		8	7.5		133056	NPQP-L-R14-Q8-FD-P10				
		10	12		133057	NPQP-L-R14-Q10-FD-P10				
	R3/8	10	13		133058	NPQP-L-R38-Q10-FD-P10				
		12	18		133059	NPQP-L-R38-Q12-FD-P10				

- 1) With sealing ring
- 2) Packaging unit quantity



Ordering data – One-way flow control valves					Technical data → Internet: crgrla		
	Connection		Material	Part No.	Type	PU ¹⁾	
	Thread	For push-in fitting					
	M5	CRQS/CRQSL/CRQST,	Electropolished stainless steel casting	161403	CRGRLA-M5-B	1	
	G1/8	Quick Star		161404	CRGRLA-1/8-B		
	G1/4			161405	CRGRLA-1/4-B		
	G3/8			161406	CRGRLA-3/8-B		
	G1/8	Push-in connector is integrated	Chrome-plated metal	195597	GRLA-F-1/8-QS-4-D	1	
				195598	GRLA-F-1/8-QS-6-D		
				195599	GRLA-F-1/8-QS-8-D		
	G1/4			195600	GRLA-F-1/4-QS-6-D		
				195601	GRLA-F-1/4-QS-8-D		

- 1) Packaging unit quantity

Guided drives DGRF-C, Clean Design

Accessories

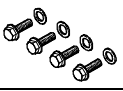
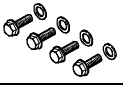
Ordering data – Plastic tubing, standard O.D.		Technical data → Internet: tubing
		Type
	Approved for use in the food industry and resistant to hydrolysis	PUN-H
	Good resistance to chemicals and hydrolysis	PLN
	Pneumatic tubing with resistance to high temperatures and chemicals	PFAN

Ordering data – Blanking screws, corrosion-resistant					
	For Ø	Description	Part No.	Type	PU ¹⁾
For mounting thread on the guide					
	20, 25	With cover plate	543715	DAMD-P-M6-12-R1	4
	32, 40, 50		543716	DAMD-P-M8-16-R1	
	63		543717	DAMD-P-M10-16-R1	
For mounting thread on the end cap					
	20, 25	With cover plate	543714	DAMD-P-M5-10-R1	4
	32 ²⁾		543715	DAMD-P-M6-12-R1	
	32 ³⁾ , 40	–	1355016	DAMD-PS-M6-12-R1	
	50, 63		650121	DAMD-PS-M8-16-R1	

- 1) Packaging unit quantity
- 2) For cylinder with P cushioning
- 3) For cylinder with PPV/PPS cushioning

Ordering data – Centring sleeves		Technical data → Internet: zbh
	For Ø	Part No. Type PU ¹⁾
	20, 25	150927 ZBH-9
	32, 40, 50, 63	189653 ZBH-12

- 1) Packaging unit quantity