

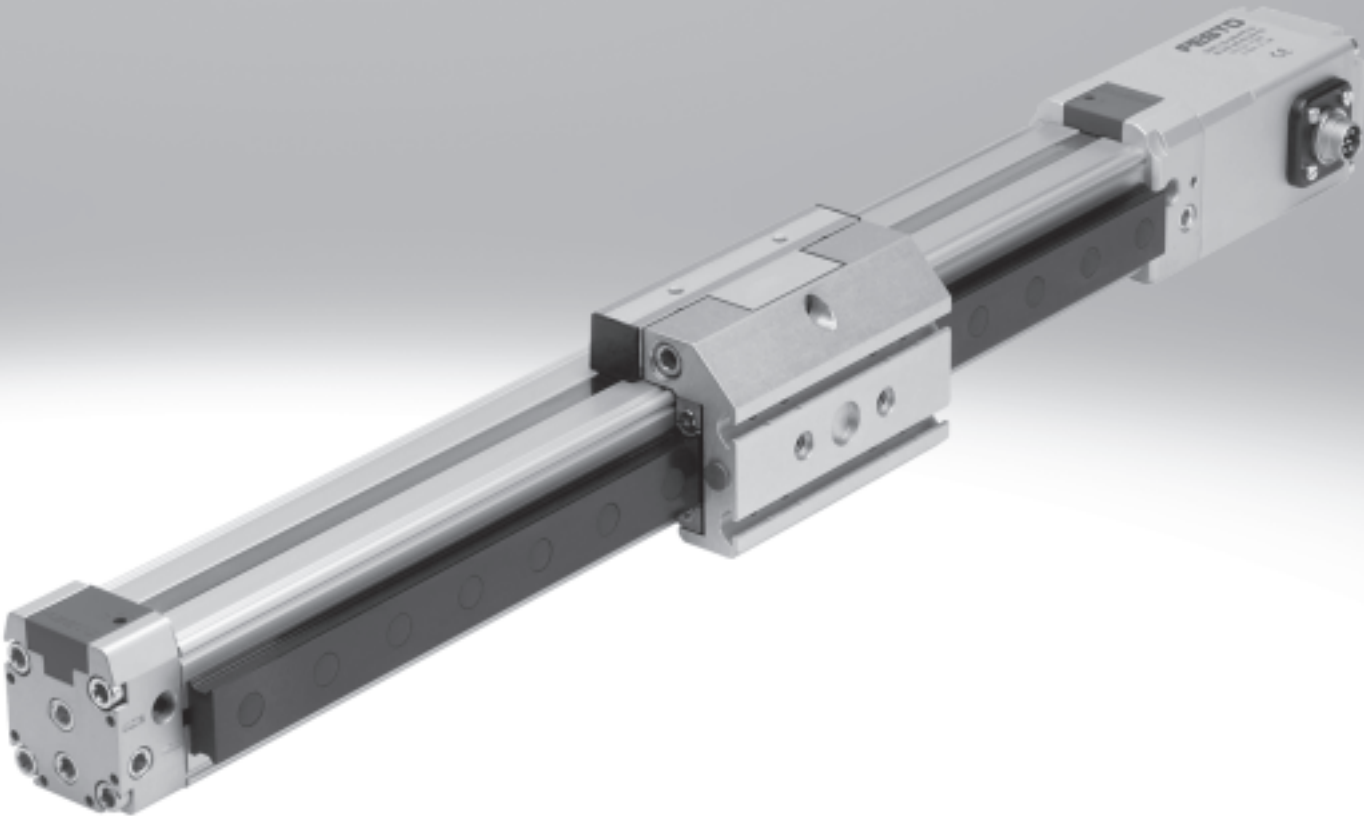

















Linear drives DGPI/DGPIL, with integrated displacement encoder



Cylinders with displacement encoder

Product range overview

Function	Type	Brief description
Drives	Rodless	
	DDLI 	<ul style="list-style-type: none"> • Without guide • With contactless measuring displacement encoder • Based on linear drive DGC-K • Supply ports on end face • System product for handling and assembly technology
	DDCI 	<ul style="list-style-type: none"> • With guide • With contactless measuring displacement encoder • Based on linear drive DGC • Supply ports optionally on end face or front • System product for handling and assembly technology
	DGP/ DGPIL 	<p>Do not use for new projects!</p> <ul style="list-style-type: none"> • With or without guide • With contactless measuring displacement encoder, integrated • Wide range of options for mounting on drives • System product for handling and assembly technology
	DGP/ DGPL 	<p>Do not use for new projects!</p> <ul style="list-style-type: none"> • With or without guide • With potentiometer or contactless measuring displacement encoder, attached • With clamping unit • Wide range of options for mounting on drives
	With piston rod	
	DNCI 	<ul style="list-style-type: none"> • With contactless measuring displacement encoder • Various piston rod variants • Standards-based cylinder to ISO 15552 <p>    </p>
	DDPC 	<ul style="list-style-type: none"> • With contactless measuring displacement encoder • Various piston rod variants • Standards-based cylinder to ISO 15552 <p>    </p>
	DNC/ DSBC 	<ul style="list-style-type: none"> • With attached potentiometer MLO-LWG • Various piston rod variants • Standards-based cylinder to ISO 15552 <p>    </p>
	Swivel modules	Swivel modules
DSMI 		<ul style="list-style-type: none"> • Based on swivel modules DSM • Integrated rotary potentiometer • Compact design • Wide range of mounting options

Cylinders with displacement encoder

Product range overview

Piston Ø	Stroke/swivel angle [mm/°]	Suitable				
		for positioning with		for end-position controller		for use as a measuring cylinder
		CPX-CMAX	SPC200	CPX-CMPX	SPC11	
Rodless						
25, 32, 40	100, 160, 225, 300, 360, 450, 500, 600, 750, 850, 1000, 1250, 1500, 1750, 2000	■	■	■	■	■
18, 25, 32, 40, 63	100, 160, 225, 300, 360, 450, 500, 600, 750, 850, 1000, 1250, 1500, 1750, 2000	■	■	■	■	■
25, 32, 40, 50, 63	225, 300, 360, 450, 500, 600, 750, 1000, 1250, 1500, 1750, 2000	■	■	■	■	■
25, 32, 40, 50, 63	225, 300, 360, 450, 500, 600, 750, 1000, 1250, 1500, 1750, 2000	-	■	-	■	■
With piston rod						
32, 40, 50, 63	10 ... 2000	-	-	-	-	■
	100 ... 750	■	■	■	■	-
80, 100	10 ... 2000	-	-	-	-	■
	100 ... 750	■	■	■	■	-
32, 40, 50, 63, 80	100, 150, 225, 300, 360, 450, 600, 750	■	■	■	■	■
Swivel modules						
25, 40, 63	270	■	■	■	■	■

Cylinders with displacement encoder

Features

FESTO

Servopneumatic drive technology

Positioning and Soft Stop applications as an integral component of the valve terminal CPX – the modular peripheral system for decentralised automation tasks.

The modular design means that valves, digital inputs and outputs, positioning modules and end-position controllers, as appropriate to the application, can be combined in almost any way on the CPX terminal.

Advantages:

- Pneumatics and electrics – control and positioning on one platform
- Innovative positioning technology – piston rod drives, rodless drives, rotary drives
- Actuation via fieldbus
- Remote maintenance, remote diagnostics, web server, SMS and e-mail alerts are all possible via TCP/IP
- Modules can be quickly exchanged and expanded without altering the wiring

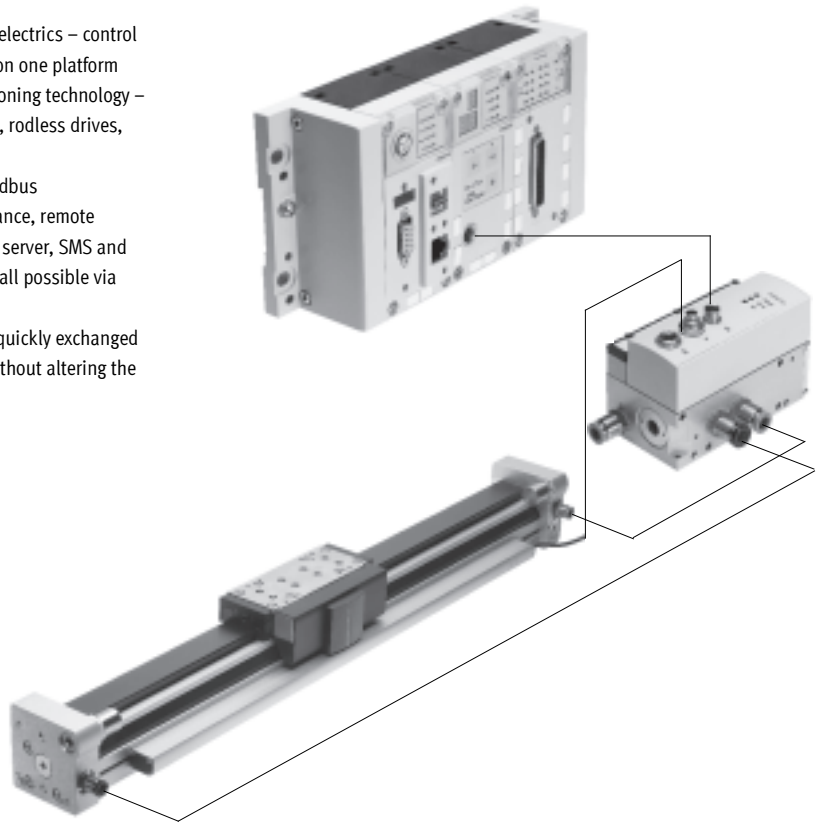

Axis controller CPX-CMAX



Free choice:

Position and force control, directly actuated or selected from one of 64 configurable position sets. If you are looking for something more: the configurable function for switching to the next set enables simple functional sequences to be realised with the axis controller CPX-CMAX.

All stations are recognised as: the auto-identification function identifies each participant with its device data on the controller CPX-CMAX.

Also included:

The functional scope of the controller CPX-CMAX includes actuation of a brake or clamping unit via the proportional directional control valve VPWP.

Up to 8 modules (max. 8 axes) can be operated in parallel and independently of each other. Commissioning via FCT (Festo configuration software) or via fieldbus: no programming, only configuration.

Technical data → Internet: cpx-cmax

Advantages:

- Greater flexibility
- OEM friendly – commissioning also via fieldbus
- Easy installation and fast commissioning
- Cost-effective
- You program the system in your PLC environment

Cylinders with displacement encoder

Features

FESTO

End-position controller CPX-CMPX



Fast travel between the mechanical end stops of the cylinder, stopping gently and without impact in the end position.
Fast commissioning via control panel, fieldbus or handheld unit. Improved control of downtime. Actuation of a brake or clamping unit via the proportional directional control valve VPWP is an integral part of the controller CMPX.

Depending on the fieldbus chosen, up to 9 end-position controllers can be actuated on the CPX terminal. All system data can be read and written via the fieldbus, including, for example, the mid positions.

Technical data → Internet: [cpx-cmpx](#)

- Advantages:
- Greater flexibility
 - OEM friendly – commissioning also via fieldbus
 - Easy installation and fast commissioning
 - Cost-effective
 - up to 30% faster cycle rates
 - significantly reduced system vibration
 - Improved work ergonomics thanks to significantly reduced noise level
 - The extended diagnostics help to reduce the service time of the machine

Proportional directional control valve VPWP



The 5/3-way proportional directional control valve for applications with Soft Stop and pneumatic positioning. Fully digitalised – with integrated pressure sensors, with new diagnostic functions. In sizes 4, 6, 8 and 10. Flow rate of 350, 700, 1400 and 2000 l/min.

With switching output for actuating a brake. Coloured supply ports. Pre-assembled cables guarantee faultless and fast connection with the controllers CPX-CMPX and CPX-CMAX.

Technical data → Internet: [vpwp](#)

- Advantages:
- Easy installation and fast commissioning
 - Reduction of system downtimes thanks to the new diagnostic options
 - With switching output for actuating a brake/clamping unit

Measuring module CPX-CMIX



Fully digital data acquisition and transmission means that pneumatic cylinders can be used as sensors. With very high repetition accuracy and incorporating both analogue and digital measuring sensors.

Suitable for the linear drive DGCI with displacement encoder for measuring absolute values, for the piston rod drive DNCI/DDPC with incremental displacement encoder or even for a potentiometer of the type MLO.

Technical data → Internet: [cpx-cmix](#)

- Advantages:
- All process steps can be documented, which improves quality
 - An adjustable contact force (via pressure regulator) increases the precision of the "displacement sensor"
 - With displacement encoders for measuring absolute values, the actual position is immediately available after the system is switched on

Cylinders with displacement encoder

Drive options

FESTO

System with linear drive DDLI, DGCI

Technical data → Internet: [ddli](#) or [dgci](#)

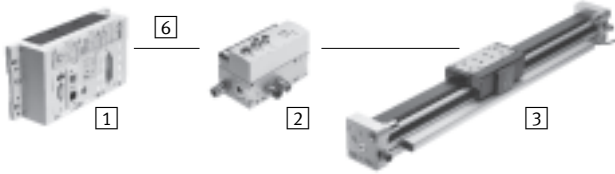

- 1 Controller module CPX-CMPX or CPX-CMAX
- 2 Proportional directional control valve VPWP
- 3 Linear drive DDLI, DGCI with displacement encoder
- 6 Connecting cable KVI-CP-3-...

- Pneumatic rodless linear drive with displacement encoder, with or without recirculating ball bearing guide
- Displacement encoder with absolute and contactless measurement
- Diameters:
 - DGCI: 18 ... 63 mm
 - DDLI: 25 ... 40 mm
- Stroke: 100 ... 2000 mm in fixed lengths
- Range of applications: Soft Stop and pneumatic positioning
- Loads from 1 ... 180 kg
- No sensor interface required

Advantages:

- Complete drive unit
- DDLI for easy connection to customer's guide system
- Excellent running characteristics
- For fast and accurate positioning down to ± 0.2 mm (only with axis controller CPX-CMAX)

System with linear drive DGPI, DGPII or displacement encoder MME-MTS

Technical data → Internet: [dgpI](#)

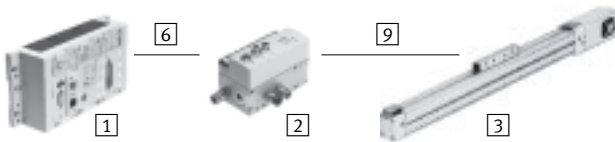

- 1 Controller module CPX-CMPX or CPX-CMAX
- 2 Proportional directional control valve VPWP
- 3 Linear drive DGPI, DGPII with displacement encoder
- 6 Connecting cable KVI-CP-3-...
- 9 NEBP-M16W6-K-2-M9W5

- Pneumatic rodless linear drive with displacement encoder, with or without recirculating ball bearing guide
- Displacement encoder with absolute and contactless measurement
- Diameter: 25 ... 63 mm
- Stroke: 225 ... 2000 mm in fixed lengths
- Range of applications: Soft Stop and pneumatic positioning
- Loads from 2 ... 180 kg
- No sensor interface required

Advantages:

- Complete drive unit
- DGPI for easy connection to customer's guide system
- Excellent running characteristics
- For fast and accurate positioning down to ± 0.2 mm (only with axis controller CPX-CMAX)

System with standard cylinder DNCI, DDPC

Technical data → Internet: [dnCI](#)

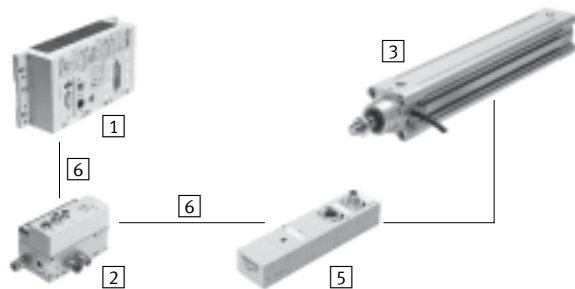

- 1 Controller module CPX-CMPX or CPX-CMAX
- 2 Proportional directional control valve VPWP
- 3 Standard cylinder DNCI, DDPC with displacement encoder
- 5 Sensor interface CASM-S-D3-R7
- 6 Connecting cable KVI-CP-3-...

- Standard cylinder with integrated displacement encoder, conforms to DIN ISO 6432, VDMA 24 562, NF E 49 003.1 and Uni 10 290
- Displacement encoder with contactless and incremental measuring
- Diameter: 32 ... 100 mm
- Stroke: 100 ... 750 mm
- Range of applications: Soft Stop and pneumatic positioning
- Loads from 3 ... 450 kg and a matching sensor interface CASM-S-D3-R7
- Pre-assembled cables guarantee faultless and fast electrical connection

Advantages:

- Compact drive unit
- Can be used universally
- Also with guide unit
- For fast and accurate positioning up to ± 0.5 mm (only with axis controller CPX-CMAX)

Cylinders with displacement encoder

Drive options

FESTO

System with swivel module DSMI

Technical data → Internet: [dsmi](#)

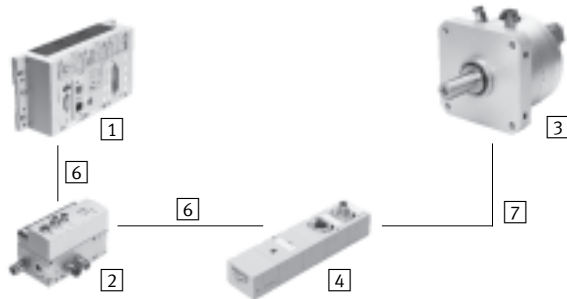

- 1 Controller module CPX-CMPX or CPX-CMAX
- 2 Proportional directional control valve VPWP
- 3 Swivel module DSMI with displacement encoder
- 4 Sensor interface CASM-S-D2-R3
- 6 Connecting cable KVI-CP-3-...
- 7 Connecting cable NEBC-P1W4-K-0,3-N-M12G5

- Swivel module DSMI with integrated displacement encoder
- Identical design to pneumatic swivel module DSM
- Absolute displacement encoder based on a potentiometer
- Swivel range of 0 ... 270°
- Size: 25, 40, 63
- Max. torque: 5 ... 40 Nm
- Range of applications: Soft Stop and pneumatic positioning
- Mass moments of inertia from 15 ... 6000 kgcm² and a matching sensor interface CASM-S-D2-R3
- Pre-assembled cables guarantee faultless and fast connection with the proportional directional control valve VPWP

Advantages:

- Complete drive unit, compact, can be used immediately
- High angular acceleration
- With adjustable fixed stops
- For fast and accurate positioning down to ±0.2° (only with axis controller CPX-CMAX)

System with potentiometer

Technical data → Internet: [casm](#)

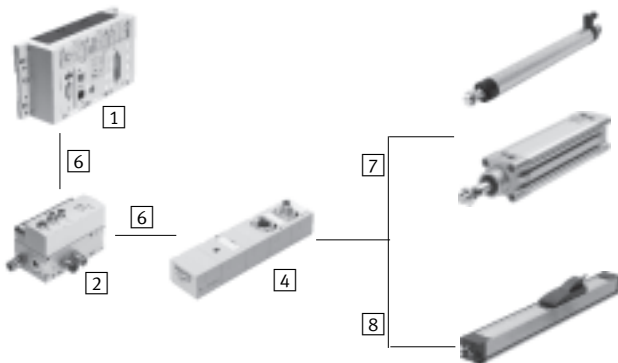

- 1 Controller module CPX-CMPX or CPX-CMAX
- 2 Proportional directional control valve VPWP
- 4 Sensor interface CASM-S-D2-R3
- 6 Connecting cable KVI-CP-3-...
- 7 Connecting cable NEBC-P1W4-K-0,3-N-M12G5
- 8 Connecting cable NEBC-A1W3-K-0,4-N-M12G5

- Attachable potentiometers with absolute measurement, with high degree of protection
- With connecting rod or moment compensator
- Measuring range: 100 ... 2000 mm
- Pre-assembled cables guarantee faultless and fast connection with the sensor interface CASM
- Range of applications: Soft Stop and pneumatic positioning with cylinder Ø 25 ... 80 mm, e.g. DNC or DSBC
- Loads from 1 ... 300 kg

Advantages:

- Easy installation and fast commissioning
- Cost-effective
- Can also be used in harsh ambient conditions
- Variety of drives: CPX-CMPX and CPX-CMAX also support cylinders with external displacement encoder

Cylinders with displacement encoder

Drive options

System components for Soft Stop systems with end-position controller CPX-CMPX							
	Linear drive		Standard cylinder	Swivel module	Displacement encoder		→ Page/ Internet
	DDLI/DGCI	DGPI	DNCI, DDPC	DSMI	MLO-LWG/-TLF	MME-MTS	
End-position controller CPX-CMPX	■	■	■	■	■	■	cmpx
Prop. directional control valve VPWP	■	■	■	■	■	■	vpwp
Sensor interface CASM-S-D2-R3	-	-	-	■	■	-	casm
Sensor interface CASM-S-D3-R7	-	-	■	-	-	-	casm
Connecting cable KVI-CP-3-...	■	■	■	■	■	■	kvi
Connecting cable NEBC-P1W4-...	-	-	-	■	■ / -	-	nebc
Connecting cable NEBC-A1W3-...	-	-	-	-	- / ■	-	nebc
Connecting cable NEBP-M16W6-...	-	■	-	-	-	■	nebp

System components for pneumatic positioning systems with axis controller CPX-CMAX							
	Linear drive		Standard cylinder	Swivel module	Displacement encoder		→ Page/ Internet
	DDLI/DGCI	DGPI	DNCI, DDPC	DSMI	MLO-LWG/-TLF	MME-MTS	
Axis controller CPX-CMAX	■	■	■	■	■	■	cmax
Prop. directional control valve VPWP	■	■	■	■	■	■	vpwp
Sensor interface CASM-S-D2-R3	-	-	-	■	■	-	casm
Sensor interface CASM-S-D3-R7	-	-	■	-	-	-	casm
Connecting cable KVI-CP-3-...	■	■	■	■	■	■	kvi
Connecting cable NEBC-P1W4-...	-	-	-	■	■ / -	-	nebc
Connecting cable NEBC-A1W3-...	-	-	-	-	- / ■	-	nebc
Connecting cable NEBP-M16W6-...	-	■	-	-	-	■	nebp

System components for measuring cylinders with measuring module CPX-CMIX							
	Linear drive		Standard cylinder	Swivel module	Displacement encoder		→ Page/ Internet
	DDLI/DGCI	DGPI	DNCI, DDPC	DSMI	MLO-LWG/-TLF	MME-MTS	
Measuring module CPX-CMIX-M1-1	■	■	■	■	■	■	cmix
Sensor interface CASM-S-D2-R3	-	-	-	■	■	-	casm
Sensor interface CASM-S-D3-R7	-	-	■	-	-	-	casm
Connecting cable KVI-CP-3-...	(■) ¹⁾	(■) ¹⁾	■	■	■	(■)	kvi
Connecting cable NEBC-P1W4-...	-	-	-	■	■ / -	-	nebc
Connecting cable NEBC-A1W3-...	-	-	-	-	- / ■	-	nebc
Connecting cable NEBP-M16W6-...	-	■	-	-	-	■	nebp

1) As an extension

Cylinders with displacement encoder

Overview

Individual components for positioning

With axis controller SPC200

→ Internet: [spc200](#)

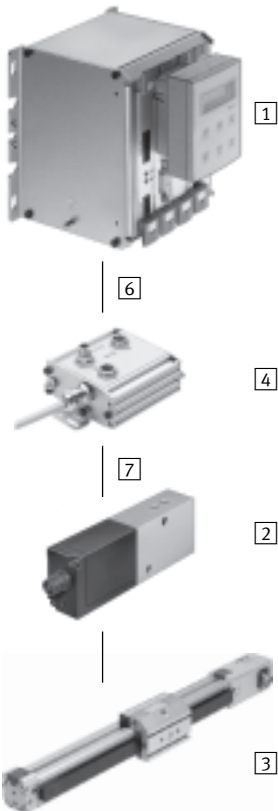

- 1 Axis controller SPC200
- 2 Proportional directional control valve MPYE
- 3 Linear drive DGPI, DGPI L
- 4 Axis interface SPC-AIF-MTS
- 6 Connecting cable KSPC-AIF-...
- 7 Connecting cable KMPYE-AIF-...

With end-position controller SPC11

→ Internet: [spc11](#)

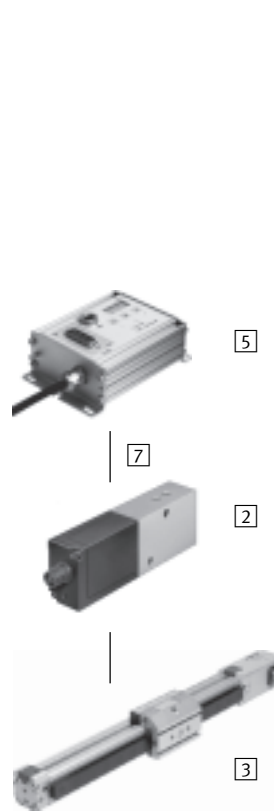

- 2 Proportional directional control valve MPYE
- 3 Linear drive DGPI, DGPI L
- 5 End-position controller SPC11-MTS-AIF
- 7 Connecting cable KMPYE-AIF-...

DGPI, without guide

10

- Piston \varnothing 25 ... 63 mm
- Stroke 225 ... 2,000 mm
- Standard moment compensator
- Low characteristic load values
- Supply ports on both sides



DGPIL, with recirculating ball bearing guide

24

- Piston \varnothing 25 ... 63 mm
- Stroke 225 ... 2,000 mm
- Standard slide
- High characteristic load values
- Supply ports on both sides



- 1 - Type discontinued
Available up until 2014

Linear drives DGPI, with integrated displacement encoder

Peripherals overview

FESTO

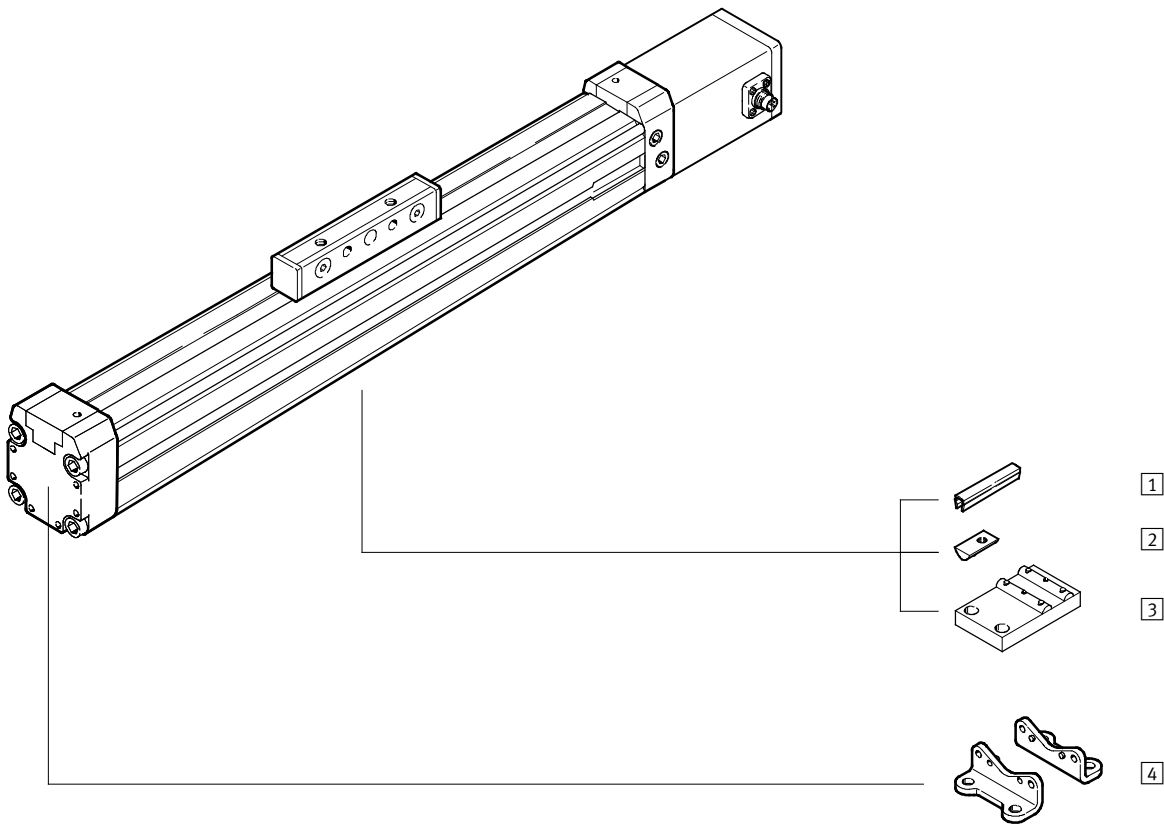

Variants and accessories		
Type	Brief description	→ Page/Internet
1 Slot cover B/S	For protecting against the ingress of dirt	41
2 Slot nut Y	For mounting attachments	41
3 Central support M	For mounting the axis	38
4 Foot mounting F	For mounting the axis	38

Linear drives DGPI, with integrated displacement encoder

Type codes

	DGPI	-	25	-	500	-	PPV	-	AIF	-	GK	-	AV	-	D2	-	4BYF	
Type																		
DGPI	Linear drive																	
Piston Ø [mm]																		
Stroke [mm]																		
Cushioning																		
PPV	Adjustable at both ends																	
Displacement encoder																		
AIF	CAN axis interface																	
Basic design																		
GK	Standard slide																	
Connection position for displacement encoder and compressed air																		
AH	Connections at rear																	
AU	Connections underneath																	
AV	Connections at front																	
Supply port																		
D2	Supply port at both ends																	
Accessories enclosed separately																		
...S	Slot cover for sensor slot																	
...B	Slot cover for mounting slot																	
...Y	Slot nut for mounting slot																	
...M	Central support																	
...F	Foot mounting																	

-  - Type discontinued
Available up until 2014



Linear drives DGPI, with integrated displacement encoder

FESTO

Technical data

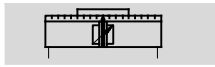
Function



-  - Diameter
25 ... 63 mm
-  - Stroke length
225 ... 2,000 mm

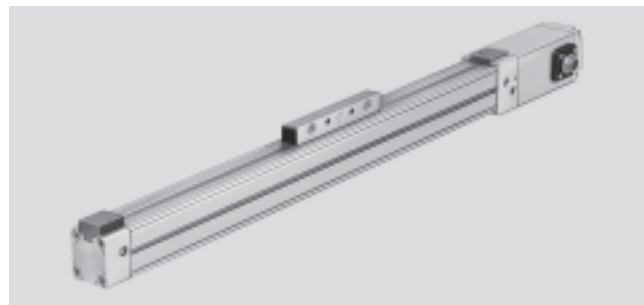

General technical data					
Piston Ø	25	32	40	50	63
Design	Piston Moment compensator Profile barrel				
Mode of operation	Double-acting				
Operating medium ¹⁾	Compressed air according to ISO 8573-1:2010 [6:4:4]				
Note about the operating/pilot medium	Lubricated operation not possible Pressure dew point 10 °C below ambient temperature/temperature of medium				
Cushioning	Adjustable at both ends				
Cushioning length [mm]	18	20	30		
Position sensing	Integrated displacement encoder				
Measuring principle	Digital, magnetostrictive, non-contacting and absolute measurement				
Type of mounting	Foot mounting				
Stroke ²⁾³⁾ [mm]	225; 300; 360; 450; 500; 600; 750; 1,000; 1,250; 1,500; 1,750; 2,000				
Pneumatic connection	G ¹ / ₈		G ¹ / ₄		G ³ / ₈
Electrical connection	6-pin round plug to DIN 45322				

- 1) The proportional directional control valve MPYE used requires the characteristic values.
- 2) Note stroke reduction in combination with SPC200.
- 3) Supply of compressed air to each end of the cylinder (feature D2) is absolutely essential for Soft Stop SPC11 and axis controller SPC200 as of a length of 500 mm.

Forces [N] and impact energy [Nm]					
Piston Ø	25	32	40	50	63
Theoretical force at 6 bar	295	483	754	1,178	1,870
Max. impact energy in the end positions ¹⁾	0.1	0.2	0.4	0.8	0.8

- 1) Cushioning PPV must be completely open for applications with Soft Stop SPC11 and axis controller SPC200.

Permissible impact velocity:

$$v_{\text{perm.}} = \sqrt{\frac{2 \times E_{\text{perm.}}}{m_{\text{dead}} + m_{\text{load}}}}$$

Maximum permissible load:

$$m_{\text{load}} = \frac{2 \times E_{\text{perm.}}}{v^2} - m_{\text{dead}}$$

$v_{\text{perm.}}$ Permissible impact velocity
 $E_{\text{perm.}}$ Maximum impact energy
 m_{dead} Moving mass (drive)
 m_{load} Moving effective load

-  - Note
 These specifications represent the maximum values that can be achieved. Note the maximum permissible impact energy.

Linear drives DGPI, with integrated displacement encoder

Technical data

Positioning characteristics with axis controller SPC200					
Piston Ø	25	32	40	50	63
Repetition accuracy [mm]	→ 14				
Mounting position	Any				
Minimum load, horizontal ¹⁾ [kg]	2	3	5	8	12
Maximum load, horizontal ¹⁾ [kg]	30	45	75	120	180
Minimum load, vertical ¹⁾ [kg]	2	3	5	8	12
Maximum load, vertical ¹⁾ [kg]	10	15	25	40	60
Minimum travel speed [m/s]	0.05				
Maximum travel speed [m/s]	3				
Typical positioning time, long stroke ²⁾ [s]	0.75/1.20	0.85/1.20	0.75/1.20	0.95/1.25	0.90/1.20
Typical positioning time, short stroke ³⁾ [s]	0.40/0.60	0.45/0.60	0.40/0.60	0.50/0.65	0.50/0.65
Minimum positioning stroke ⁴⁾ [%]	3				
Stroke reduction ⁵⁾ [mm]	25		35		
Recommended proportional directional control valve	→ 42				

1) Load = effective load + mass of all moving parts on the drive

2) At 6 bar, horizontal mounting position, DGPI-XX-1250, 1,000 mm travel at min./max. load

3) At 6 bar, horizontal mounting position, DNCM-XX-1250, 100 mm travel at min./max. load

4) In relation to the maximum stroke of the drive, but never more than 20 mm

5) The stroke reduction must be maintained on each side of the drive, the max. positionable stroke is therefore: stroke – 2x stroke reduction

Positioning characteristics with end-position controller SPC11					
Piston Ø	25	32	40	50	63
Repetition accuracy of a mid-position ¹⁾ [mm]	±2				
Mounting position	Any				
Minimum load, horizontal ²⁾ [kg]	2	3	5	8	12
Maximum load, horizontal ²⁾ [kg]	30	45	75	120	180
Minimum load, vertical ²⁾ [kg]	2	3	5	8	12
Maximum load, vertical ²⁾ [kg]	10	15	25	40	60
Travel time [s]	→ SoftStop sizing software: → www.festo.com				
Recommended proportional directional control valve	→ 42				

1) In the stroke range from 225 ... 2,000 mm

2) Load = effective load + mass of all moving parts on the drive

Operating and environmental conditions					
Piston Ø	25	32	40	50	63
Operating pressure ¹⁾ [bar]	4 ... 8				
Ambient temperature [°C]	-10 ... +60				
Vibration resistance	To DIN/IEC 68 Parts 2 – 6, severity level 1				
Continuous shock resistance	To DIN/IEC 68 Parts 2 – 27, severity level 1				
CE marking (see declaration of conformity)	To EU EMC Directive				
Protection class (displacement encoder)	IP65 to IEC 60 529				
Corrosion resistance class CRC ²⁾	1				

1) Only applies to applications with Soft Stop SPC11 and axis controller SPC200

2) Corrosion resistance class 1 according to Festo standard 940 070

Components subject to low corrosion stress. Transport and storage protection. Parts that do not have primarily decorative surface requirements, e.g. in internal areas that are not visible or behind covers.

Weight [g]					
Piston Ø	25	32	40	50	63
Basic weight	1,540	2,150	3,500	6,980	10,600
Additional weight per 10 mm stroke	38	43	59	130	168
Moving load	180	314	551	1,045	1,775

-  - Type discontinued
Available up until 2014

Linear drives DGPI, with integrated displacement encoder

FESTO

Technical data

Electrical data – Displacement encoder		
Power supply	[V DC]	24 (-15/+25%)
Maximum current consumption	[mA]	90
Resolution	[mm]	≤ 0.01
Independent linearity ¹⁾	Maximum [%]	0.02
Temperature coefficient	[ppm/°K]	≤ 15
Interface		Digital, CAN with protocol: SPC-AIF

1) Minimum ±50 µm

Materials

Sectional view

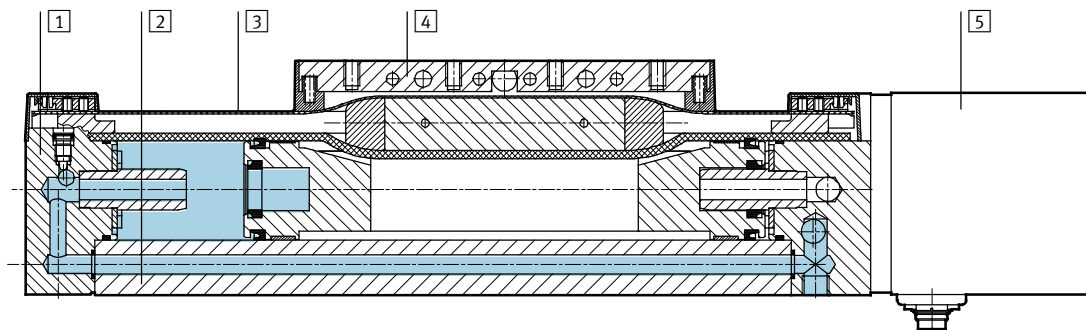

Drive

1	End cap	Anodised aluminium
2	Profile	Anodised aluminium
3	Cover strip	Corrosion-resistant steel
4	Moment compensator	Anodised aluminium
5	Displacement encoder housing	Anodised aluminium
-	Seals	Nitrile rubber, polyurethane

-  - Note

More technical data

→ Internet: dpgl

Repetition accuracy

Tolerance t [mm] as a function of stroke l [mm]

Horizontal

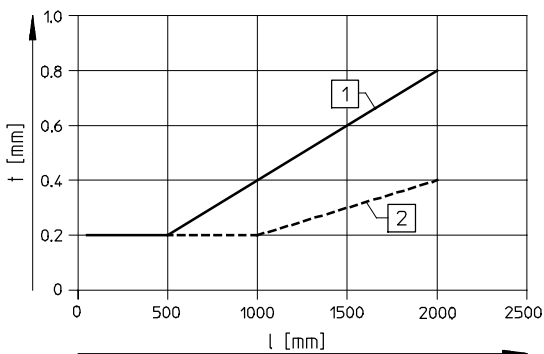

Vertical

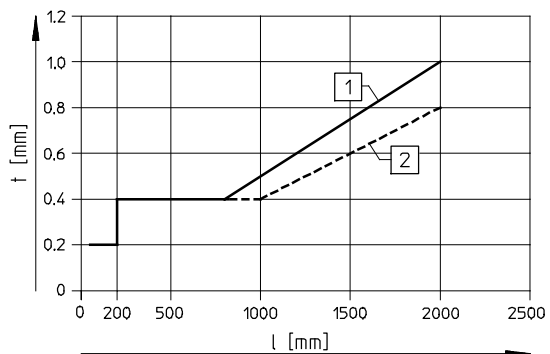

1 With analogue displacement encoder

2 With digital displacement encoder

Linear drives DGPI, with integrated displacement encoder

Technical data

Characteristic load values

The indicated forces and torques refer to the centre line of the internal diameter of the profile barrel. These values must not be exceeded during dynamic operation. Special attention must be paid to the deceleration phase.

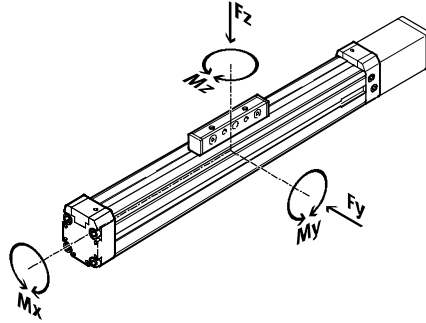

If the drive is simultaneously subjected to several of the indicated forces and torques, the following equation must be satisfied in addition to the indicated maximum loads:

$$0,4 \times \frac{F_z}{F_{z_{max}}} + \frac{M_x}{M_{x_{max}}} + \frac{M_y}{M_{y_{max}}} + 0,2 \times \frac{M_z}{M_{z_{max}}} \leq 1$$

$$\frac{F_z}{F_{z_{max}}} \leq 1 \quad \frac{M_z}{M_{z_{max}}} \leq 1$$

Permissible forces and torques

Piston Ø	25	32	40	50	63
F _{y max.} [N]	-	-	-	-	-
F _{z max.} [N]	330	480	800	1,200	1,600
M _{x max.} [Nm]	1	2	4	7	8
M _{y max.} [Nm]	20	40	60	120	120
M _{z max.} [Nm]	3	5	8	15	24

Maximum permissible support span l as a function of force F

The axis may need to be supported with central supports MUP in order to

limit deflection in the case of large strokes. The following graphs can be

used to determine the maximum permissible support span l as a function

of force F acting on the axis.

Force on the surface of the slide

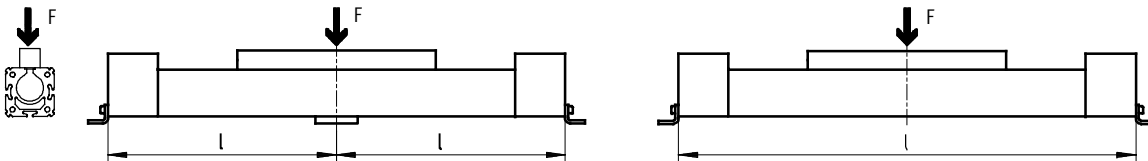

Maximum support span l (without central support) as a function of force F

Piston Ø 25 ... 40

Piston Ø 50/63

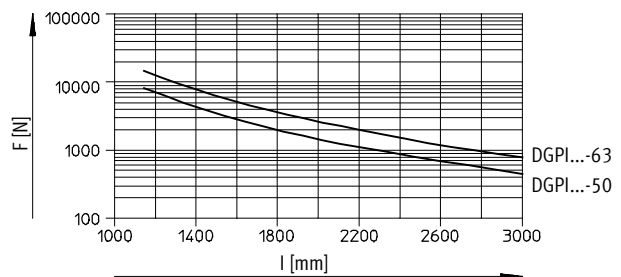
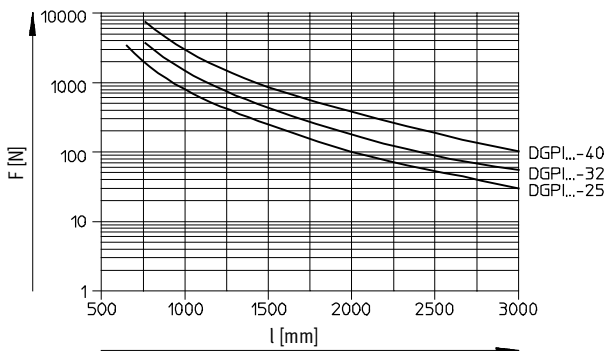

-  - Type discontinued
Available up until 2014

Linear drives DGPI, with integrated displacement encoder

FESTO

Technical data

Dimensions

Download CAD data → www.festo.com

Standard moment compensator GK

Piston \varnothing 25

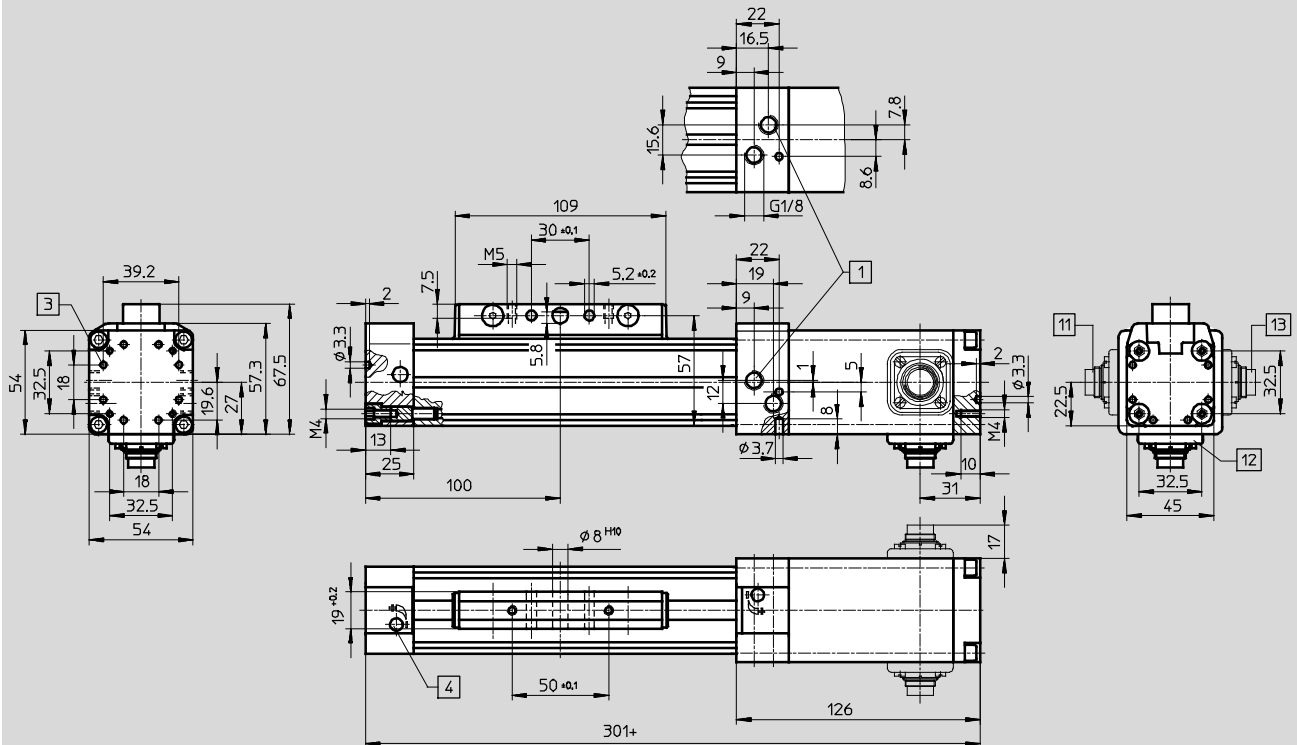

- | | |
|---|--|
| <p>1 Supply ports can optionally be used on three sides on the right-hand end cap</p> <p>3 Mounting hole for foot mounting HP</p> | <p>4 Regulating screw for adjustable end-position cushioning + = plus stroke length</p> <p>11 Connection at rear</p> <p>12 Connection underneath</p> <p>13 Connection at front</p> |
|---|--|

- 2 - Type discontinued
Available up until 2014

Linear drives DGPI, with integrated displacement encoder

FESTO

Technical data

Dimensions

Download CAD data → www.festo.com

Supply port at both ends D2

Piston $\varnothing 25$

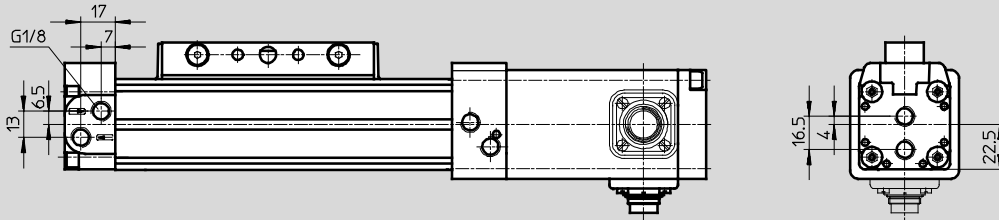

Profile barrel

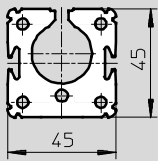

-  - Type discontinued
Available up until 2014

Linear drives DGPI, with integrated displacement encoder

Technical data

FESTO

Dimensions

Download CAD data → www.festo.com

Standard moment compensator GK

Piston Ø 32 ... 63

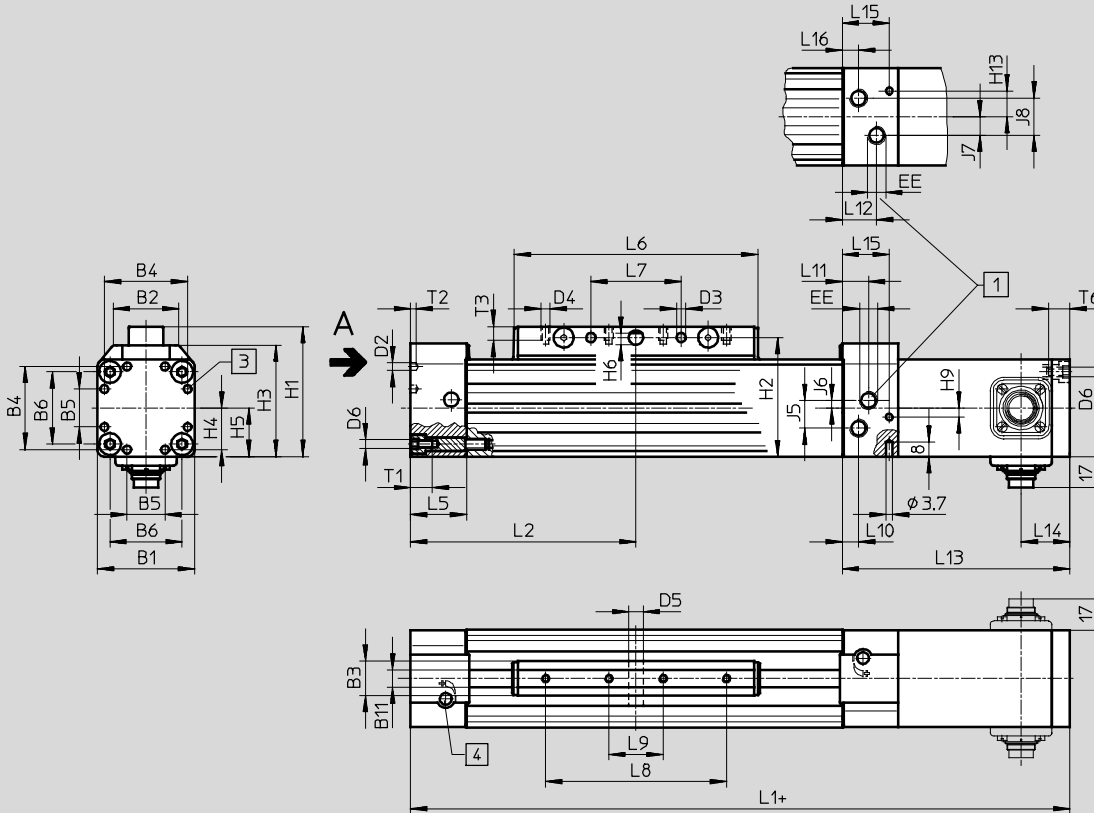

- | | |
|---|--|
| <p>1 Supply ports can optionally be used on three sides on the right-hand end cap</p> <p>3 Mounting hole for foot mounting HP</p> | <p>4 Regulating screw for adjustable end-position cushioning + = plus stroke length</p> <p>11 Connection at rear</p> <p>12 Connection underneath</p> <p>13 Connection at front</p> |
|---|--|

View A

Piston Ø 32/40

Piston Ø 50

Piston Ø 63

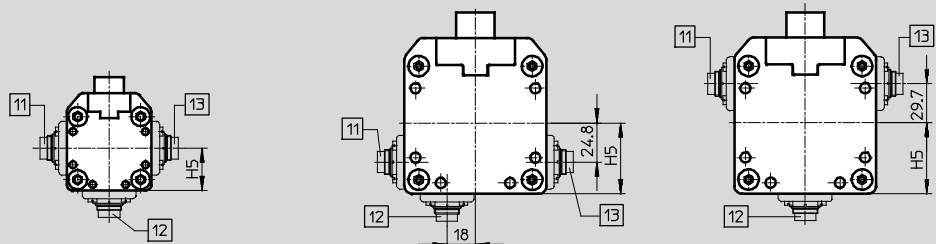

Supply port at both ends D2

Piston Ø 32 ... 63

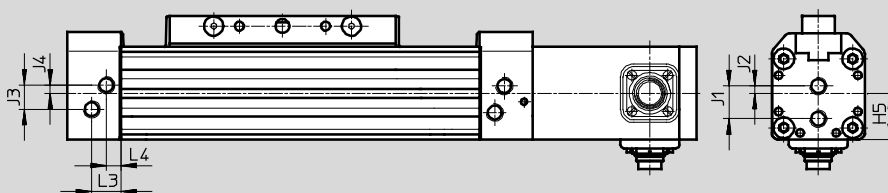

Linear drives DGPI, with integrated displacement encoder

Technical data

Dimensions Download CAD data → www.festo.com

Profile barrel

Piston Ø 32

Piston Ø 40

Piston Ø 50

Piston Ø 63

6 Mounting slot for slot nuts NST

Ø	B1	B2	B3	B4	B5	B6	B11	D2	D3	D4	D5	D6
[mm]			+0.2					Ø	Ø		Ø	
32	54	35.8	19	46	21	40	9.5	4.3	5.2	M5	8	M5
40	64	45.7	21	53	28	49	9.5	4.3	6.5	M6	10	M5
50	90	69.2	24	76	44	72	12	6.3	8.5	M8	12	M6
63	106	84.8	24	89	44	83	12	6.3	8.5	M8	12	M8

Ø	EE	H1	H2	H3	H4	H5	H6	H9	H13	J1	J2	J3
[mm]												
32	G1/8	72	66	62	23	27	5.8	5	10.3	19	4.2	14
40	G1/4	86	78	71.8	26.5	32	7.7	5	12.75	22	5	21
50	G1/4	115	106	99	36	45	9.7	21.8	16.6	31.8	6.8	29.3
63	G3/8	131	122	115	44.5	53	9.7	-28	30	36	8	31

Ø	J4	J5	J6	J7	J8	L1	L2	L3	L4	L5	L6	L7
[mm]												±0.1
32	4.7	15.4	4.2	10.3	20.6	345	125	17	8.5	31	135	50
40	9.1	23	9.1	12.75	25.5	397	150	11.5	11.5	31	171	70
50	6	20.6	6.8	21	21	465	175	14	14	34	206	80
63	14	27	8	25	25	513	200	14	14	34	234	110

Ø	L8	L9	L10	L11	L12	L13	L14	L15	L16	T1	T2	T3	T6
[mm]	±0.1	±0.1											
32	100	30	17	8.5	19	126	27	26	9	13.2	3	7.5	12
40	130	40	10.8	16.5	21	128	29	26	10.8	13.2	4	10.5	12
50	150	50	10.8	18	22.8	149	80	25.2	12	15.2	6	12.5	15
63	190	70	14	24.5	31	147.5	68	16.5	16.5	21.2	6	12.5	20

- 1 - Type discontinued
 Available up until 2014

Linear drives DGPI, with integrated displacement encoder

Ordering data – Modular products

FESTO

Order code

Mandatory data/options

D2 Supply port at both ends

GK Standard slide

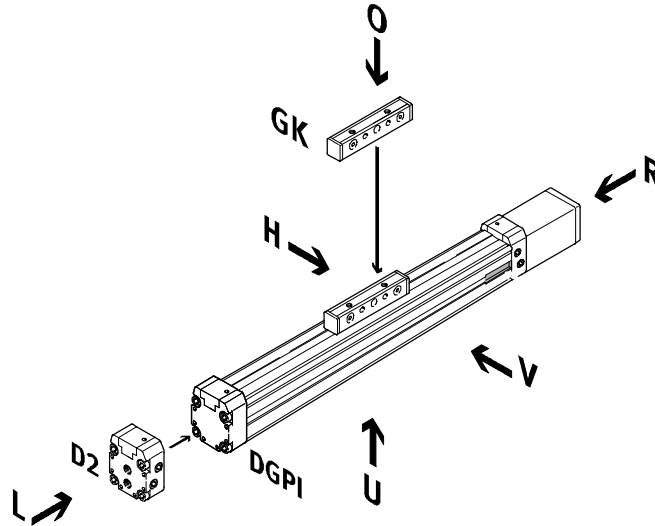

- AV Displacement encoder connection at front
- AH Displacement encoder connection at rear
- AU Displacement encoder connection underneath

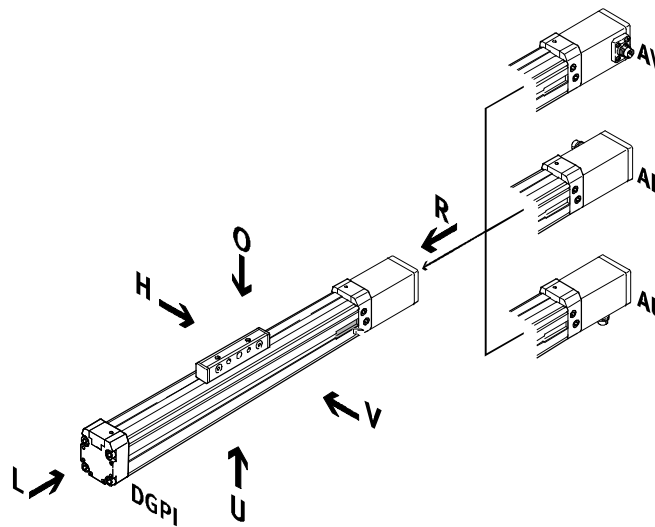

- 1 - Type discontinued
Available up until 2014

Linear drives DGPI, with integrated displacement encoder

Ordering data – Modular products

FESTO

Order code

Options

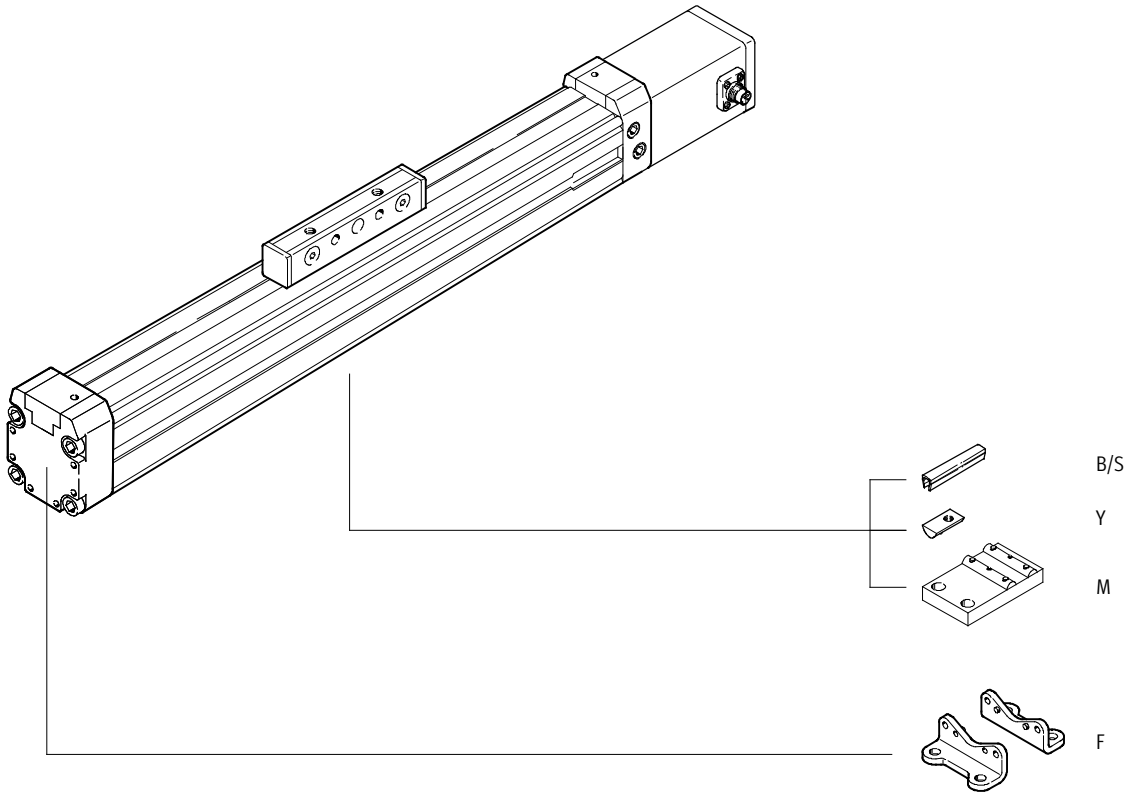

- 1 - Type discontinued
Available up until 2014

Linear drives DGPI, with integrated displacement encoder

FESTO

Ordering data – Modular products

M Mandatory data →

Module No.	Function	Size	Stroke	Cushioning	Displacement encoder	Basic design	Connection position for displacement encoder
175 134	DGPI	25	225 ... 2,000	PPV	AIF	GK	AH AU AV
175 135		32					
175 136		40					
175 137		50					
175 138		63					
Ordering example							
175 138	DGPI	- 63	- 750	- PPV	- AIF	- GK	- AV

Ordering table

Size	25	32	40	50	63	Condi- tions	Code	Enter code
M Module No.	175 134	175 135	175 136	175 137	175 138			
Function	Pneumatic linear drive with integrated displacement encoder						DGPI	DGPI
Size	25	32	40	50	63		-...	
Stroke [mm]	225; 300; 360; 450; 500; 600; 750; 1,000; 1,250; 1,500; 1,750; 2,000						-...	
Cushioning	Pneumatic cushioning, adjustable at both ends						-PPV	-PPV
Displacement encoder	Temposonic with CAN axis interface						-AIF	-AIF
Basic design	Standard piston/slide						-GK	-GK
Connection position for displacement encoder AIF and compressed air	Connection position for displacement encoder and supply port, rear						-AH	
	Connection position for displacement encoder and supply port, underneath						-AU	
	Connection position for displacement encoder and supply port, front						-AV	

Transfer order code

	DGPI	-		-		-	PPV	-	AIF	-	GK	-	
--	------	---	--	---	--	---	-----	---	-----	---	----	---	--

- 2 - Type discontinued
Available up until 2014

Linear drives DGPI, with integrated displacement encoder

FESTO

Ordering data – Modular products

Options					
Supply port	Accessories	Slot cover	Slot nut	Central support	Foot mounting
D2	ZUB	...S ...B	...Y	...M	...F
	: ZUB	- 2B2S	10Y		F

Ordering table								
Size	25	32	40	50	63	Condi- tions	Code	Enter code
↓ Supply port	At both ends						-D2	
Accessories	Enclosed separately						:ZUB-	:ZUB-
Slot cover, Sensor slot 2 pcs., 0.5 m	1 ... 10						...S	
Mounting slot	-						...B	
Slot nut Mounting slot	-						...Y	
Central support	1 ... 10						...M	
Foot mounting	1 ... 10						...F	

Transfer order code

- : ZUB -

- I - Type discontinued
Available up until 2014

Linear drives DGPII, with integrated displacement encoder

Peripherals overview

FESTO

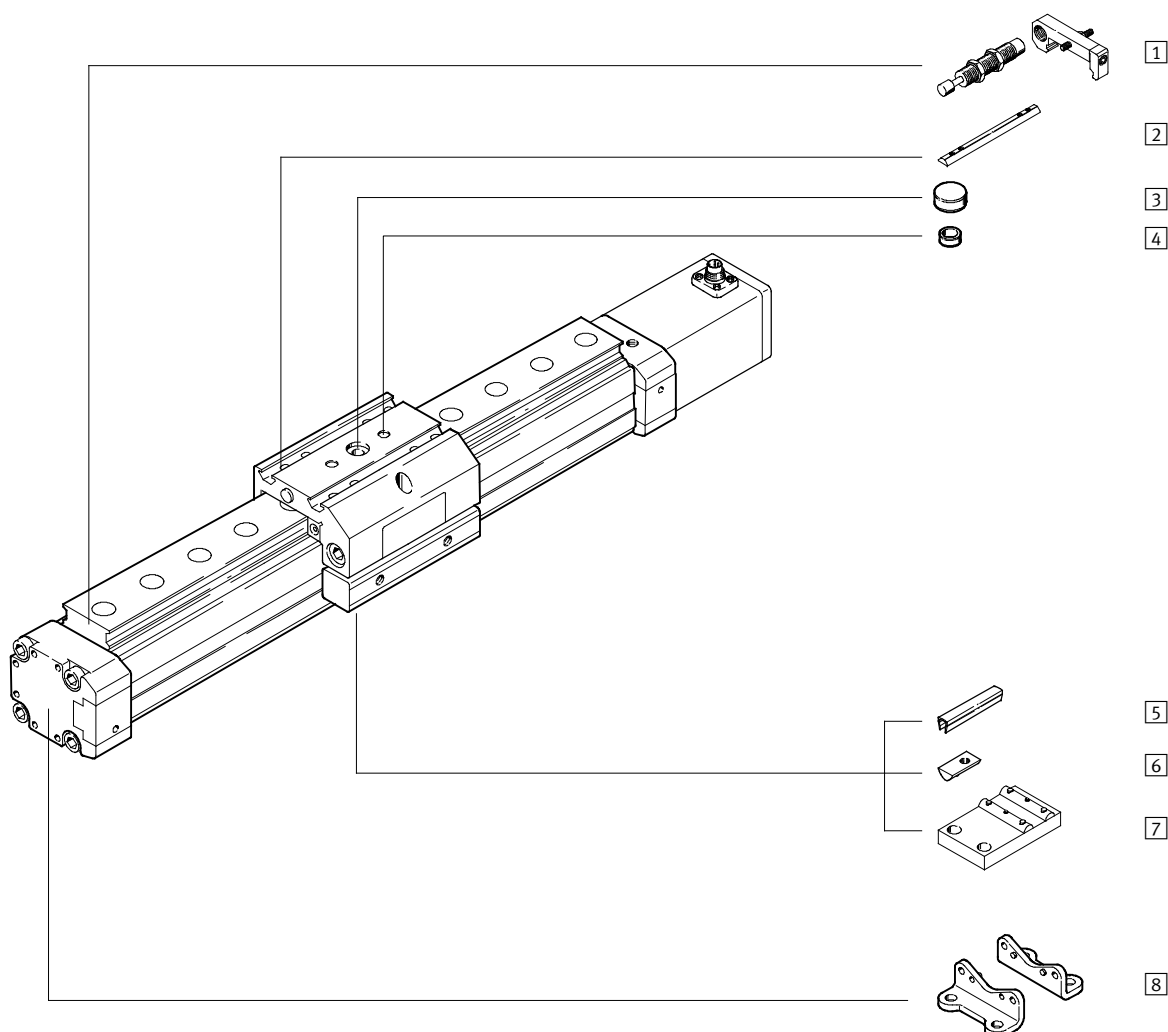

Linear drives DGPII, with integrated displacement encoder

Peripherals overview

Variants and accessories		
Type	Brief description	→ Page/Internet
1 Shock absorber kit C/E	For avoiding damage at the end stop in the event of malfunction	40
2 Slot nut for slide X	For mounting loads and attachments on the slide	41
3 Central mounting Q	For centring loads and attachments on the slide	41
4 Centring sleeves Z	For centring loads and attachments on the slide	41
5 Slot cover B/S	For protecting against the ingress of dirt	41
6 Slot nut for mounting slot Y	For mounting attachments	41
7 Central support M	For mounting the axis	38
8 Foot mounting F	For mounting the axis	38

- 1 - Type discontinued
Available up until 2014

Linear drives DGPIIL, with integrated displacement encoder

FESTO

Type codes

	DGPIL	-	25	-	500	-	PPV	-	B	-	KF	-	AIF	-	GK	-	AV	-	SV	-	D2	-	
Type	DGPIL																						
	Linear drive																						
Piston Ø [mm]																							
Stroke [mm]																							
Cushioning	PPV	Adjustable at both ends																					
Generation	B	B series																					
Guide	KF	Recirculating ball bearing guide																					
Displacement encoder	AIF	CAN axis interface																					
Basic design	GK	Standard slide																					
Connection position for displacement encoder and compressed air	AH	Connections at rear																					
	AU	Connections underneath																					
	AV	Connections at front																					
Slide attachment position	SH	Slide at rear																					
	SV	Slide at front																					
Supply port	D2	Supply port at both ends																					
Protected version	GA	Protected version																					

Linear drives DGPIIL, with integrated displacement encoder

FESTO

Type codes

		: ZUB	-	2S	2X	Z			F	2C
Accessories										
ZUB	Accessories enclosed separately									
Slot cover										
...S	Sensor slot									
...B	Mounting slot									
Slot nut										
...X	For slide									
...Y	For profile barrel									
Centring sleeves										
...Z	For slide									
Central mounting										
...Q	For slide									
Central support										
...M	Central support									
Foot mounting										
...F	Foot mounting									
Shock absorber kit										
...C	Plus retainer for GK/GV									
...E	For protected version									

-  - Type discontinued
Available up until 2014



Linear drives DGPII, with integrated displacement encoder

FESTO

Technical data

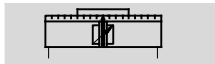
Function



-  - Diameter
25 ... 63 mm
-  - Stroke length
225 ... 2,000 mm

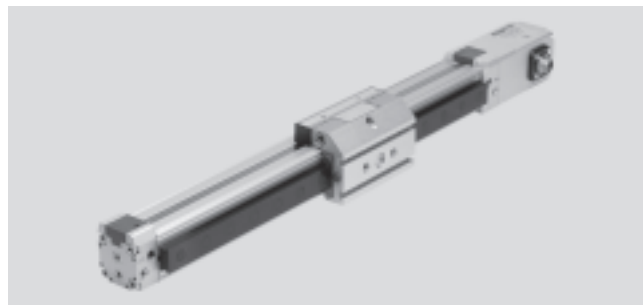

General technical data					
Piston Ø	25	32	40	50	63
Design	Piston				
	Moment compensator				
	Profile barrel				
Mode of operation	Double-acting				
Operating medium ¹⁾	Compressed air according to ISO 8573-1:2010 [6:4:4]				
Note about the operating/pilot medium	Lubricated operation not possible Pressure dew point 10 °C below ambient temperature/temperature of medium				
Cushioning	Adjustable at both ends				
Cushioning length [mm]	18	20	30		
Position sensing	Integrated displacement encoder				
Measuring principle	Digital, magnetostrictive, non-contacting and absolute measurement				
Type of mounting	Foot mounting				
Stroke ²⁾³⁾ [mm]	225; 300; 360; 450; 500; 600; 750; 1,000; 1,250; 1,500; 1,750; 2,000				
Protection against rotation/guide	Guide rail with slide Recirculating ball bearing				
Protected version ⁴⁾	Optional				
Pneumatic connection	G ¹ / ₈		G ¹ / ₄		G ³ / ₈
Electrical connection	6-pin round plug to DIN 45322				

1) The proportional directional control valve MPYE used requires the characteristic values.

2) Note stroke reduction in combination with SPC200.

3) Supply of compressed air to each end of the cylinder (feature D2) is absolutely essential for Soft Stop SPC11 and axis controller SPC200 as of a length of 500 mm.

4) Protected against particles from above and the side.

Forces [N] and impact energy [Nm]					
Piston Ø	25	32	40	50	63
Theoretical force at 6 bar	295	483	754	1,178	1,870
Max. impact energy in the end positions ¹⁾	0.1	0.2	0.4	0.8	0.8

1) Cushioning PPV must be completely open for applications with Soft Stop SPC11 and axis controller SPC200.

Permissible impact velocity:

$$v_{perm.} = \sqrt{\frac{2 \times E_{perm.}}{m_{dead} + m_{load}}}$$

Maximum permissible load:

$$m_{load} = \frac{2 \times E_{perm.}}{v^2} - m_{dead}$$

$v_{perm.}$ Permissible impact velocity
 $E_{perm.}$ Maximum impact energy
 m_{dead} Moving mass (drive)
 m_{load} Moving effective load

-  - Note
 These specifications represent the maximum values that can be achieved. Note the maximum permissible impact energy.

Linear drives DGPII, with integrated displacement encoder

Technical data

Positioning characteristics with axis controller SPC200					
Piston Ø	25	32	40	50	63
Repetition accuracy [mm]	→ 14				
Mounting position	Any				
Minimum load, horizontal ¹⁾ [kg]	2	3	5	8	12
Maximum load, horizontal ¹⁾ [kg]	30	45	75	120	180
Minimum load, vertical ¹⁾ [kg]	2	3	5	8	12
Maximum load, vertical ¹⁾ [kg]	10	15	25	40	60
Minimum travel speed [m/s]	0.05				
Maximum travel speed [m/s]	3				
Typical positioning time, long stroke ²⁾ [s]	0.75/1.20	0.85/1.20	0.75/1.20	0.95/1.25	0.90/1.20
Typical positioning time, short stroke ³⁾ [s]	0.40/0.60	0.45/0.60	0.40/0.60	0.50/0.65	0.50/0.65
Minimum positioning stroke ⁴⁾ [%]	3				
Stroke reduction ⁵⁾ [mm]	25		35		
Recommended proportional directional control valve	→ 42				

1) Load = effective load + mass of all moving parts on the drive

2) At 6 bar, horizontal mounting position, DGPII-XX-1250, 1,000 mm travel at min./max. load

3) At 6 bar, horizontal mounting position, DNCM-XX-1250, 100 mm travel at min./max. load

4) In relation to the maximum stroke of the drive, but never more than 20 mm

5) The stroke reduction must be maintained on each side of the drive, the max. positionable stroke is therefore: stroke – 2x stroke reduction

Positioning characteristics with end-position controller SPC11					
Piston Ø	25	32	40	50	63
Repetition accuracy of a mid-position ¹⁾ [mm]	±2				
Mounting position	Any				
Minimum load, horizontal ²⁾ [kg]	2	3	5	8	12
Maximum load, horizontal ²⁾ [kg]	30	45	75	120	180
Minimum load, vertical ²⁾ [kg]	2	3	5	8	12
Maximum load, vertical ²⁾ [kg]	10	15	25	40	60
Travel time [s]	→ SoftStop sizing software: → www.festo.com				
Recommended proportional directional control valve	→ 42				

1) In the stroke range from 225 ... 2,000 mm

2) Load = effective load + mass of all moving parts on the drive

Operating and environmental conditions					
Piston Ø	25	32	40	50	63
Operating pressure ¹⁾ [bar]	4 ... 8				
Ambient temperature [°C]	-10 ... +60				
Vibration resistance	To DIN/IEC 68 Parts 2 – 6, severity level 1				
Continuous shock resistance	To DIN/IEC 68 Parts 2 – 27, severity level 1				
CE marking (see declaration of conformity)	To EU EMC Directive				
Protection class (displacement encoder)	IP65 to IEC 60 529				

1) Only applies to applications with Soft Stop SPC11 and axis controller SPC200

-  - Type discontinued
Available up until 2014

Linear drives DGPII, with integrated displacement encoder

FESTO

Technical data

Weight [g]					
Piston \varnothing	25	32	40	50	63
Standard slide GK					
Basic weight	2,220	3,320	5,330	10,700	16,870
Additional weight per 10 mm stroke	55	71	99	186	256
Moving load	605	895	1,700	3,000	4,990
Additional weights with protected version GA					
Dirt protection cover	1,690	2,500	4,000	–	–
Additional weight per 10 mm stroke	26	42	65	–	–
Moving load	907	1,350	2,550	–	–

Electrical data – Displacement encoder		
Power supply	[V DC]	24 (-15/+25%)
Maximum current consumption	[mA]	90
Resolution	[mm]	≤ 0.01
Independent linearity ¹⁾	Maximum [%]	0.02
Temperature coefficient	[ppm/°K]	≤ 15
Interface		Digital, CAN with protocol: SPC-AIF

1) Minimum $\pm 50 \mu\text{m}$

Materials

Sectional view

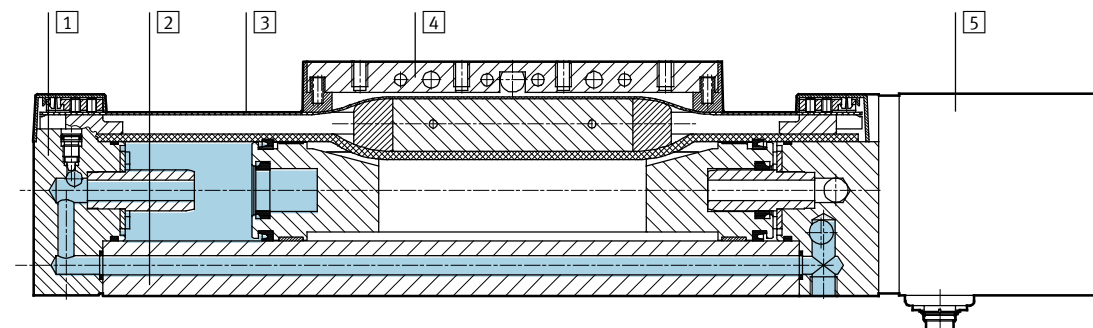

Drive		
1	End cap	Anodised aluminium
2	Profile	Anodised aluminium
3	Cover strip	Corrosion-resistant steel
4	Moment compensator	Anodised aluminium
5	Displacement encoder housing	Anodised aluminium
–	Slide	Anodised aluminium
–	Guide rail	Corrosion-resistant steel
–	Seals	Nitrile rubber, polyurethane

-  - Note

More technical data

→ Internet: dpgl

Linear drives DGPI, with integrated displacement encoder

Technical data

Characteristic load values

The indicated forces and torques refer to the centre line of the internal diameter of the profile barrel. These values must not be exceeded during dynamic operation. Special attention must be paid to the deceleration phase.

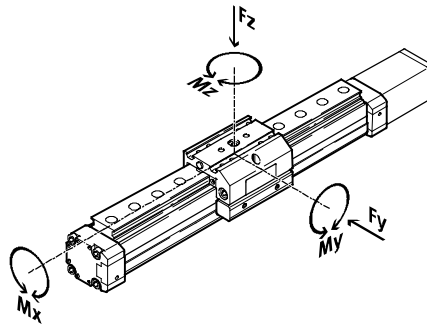

If the drive is simultaneously subjected to several of the indicated forces and torques, the following equation must be satisfied in addition to the indicated maximum loads:

$$\frac{F_y}{F_{y_{max}}} + \frac{F_z}{F_{z_{max}}} + \frac{M_x}{M_{x_{max}}} + \frac{M_y}{M_{y_{max}}} + \frac{M_z}{M_{z_{max}}} \leq 1$$

Permissible forces and torques

Piston Ø		25	32	40	50	63
F _y _{max.}	[N]	3,080	3,080	7,300	7,300	14,050
F _z _{max.}	[N]	3,080	3,080	7,300	7,300	14,050
M _x _{max.}	[Nm]	45	63	170	240	580
M _y _{max.}	[Nm]	85	127	330	460	910
M _z _{max.}	[Nm]	85	127	330	460	910

Maximum permissible support span l as a function of force F

The axis may need to be supported with central supports MUP in order to

limit deflection in the case of large strokes. The following graphs can be

used to determine the maximum permissible support span l as a function

of force F acting on the axis.

Force on the surface of the slide

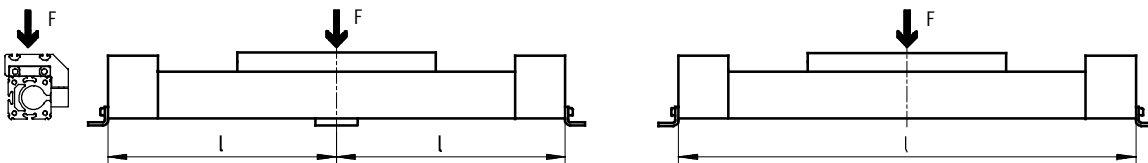

Maximum support span l (without central support) as a function of force F

Piston Ø 25 ... 40

Piston Ø 50/63

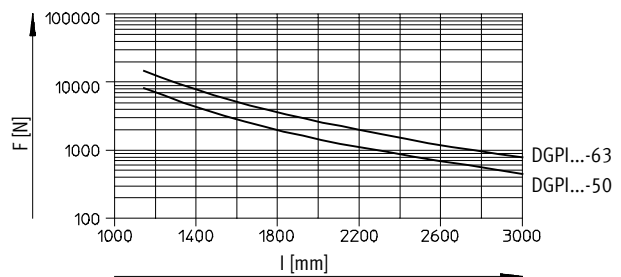
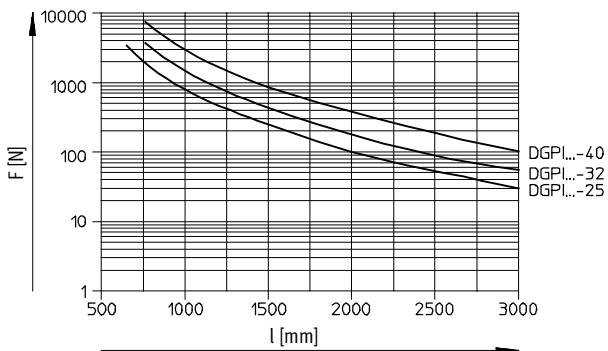

-  - Type discontinued
Available up until 2014

Linear drives DGPII, with integrated displacement encoder

Technical data

FESTO

Dimensions

Download CAD data → www.festo.com

Standard slide GK

Piston Ø 25

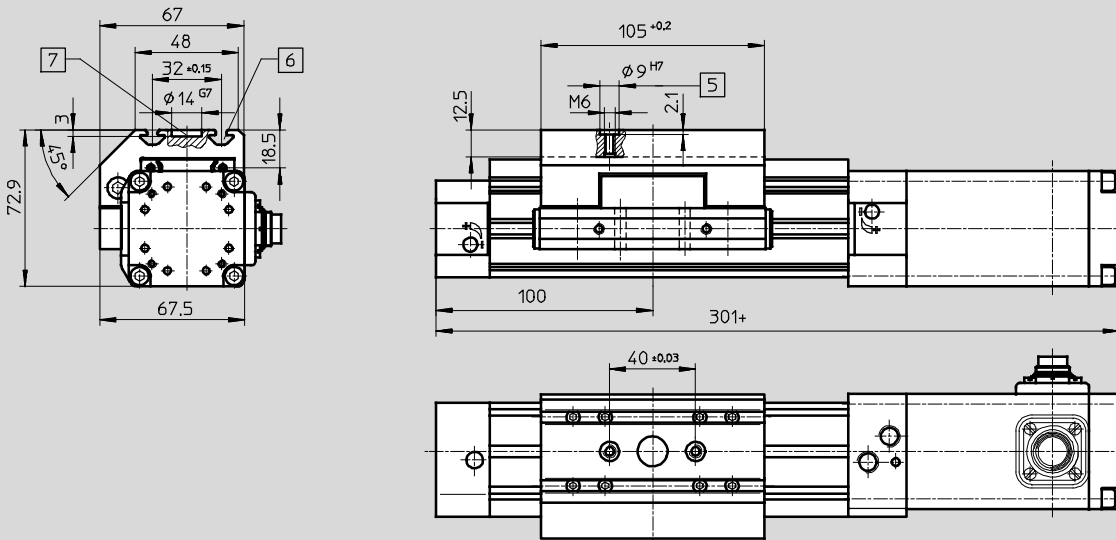

- 5 Hole for centring sleeve ZBH-9
- 6 Mounting slot for slot nut NSTL

- 7 Hole for central mounting SLZZ + = plus stroke length

Basic dimensions
→ 16

Protected version GA

Piston Ø 25

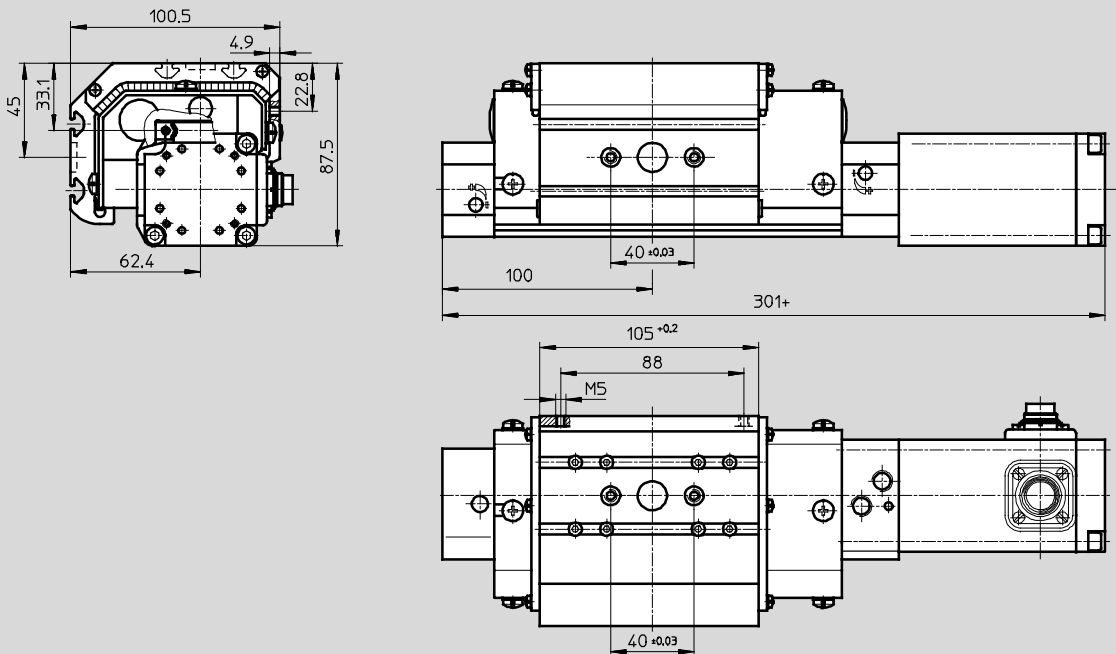

+ = plus stroke length

Basic dimensions
→ 16

Linear drives DGPII, with integrated displacement encoder



Technical data

Dimensions Download CAD data → www.festo.com

Standard slide GK

Piston \varnothing 32 ... 63

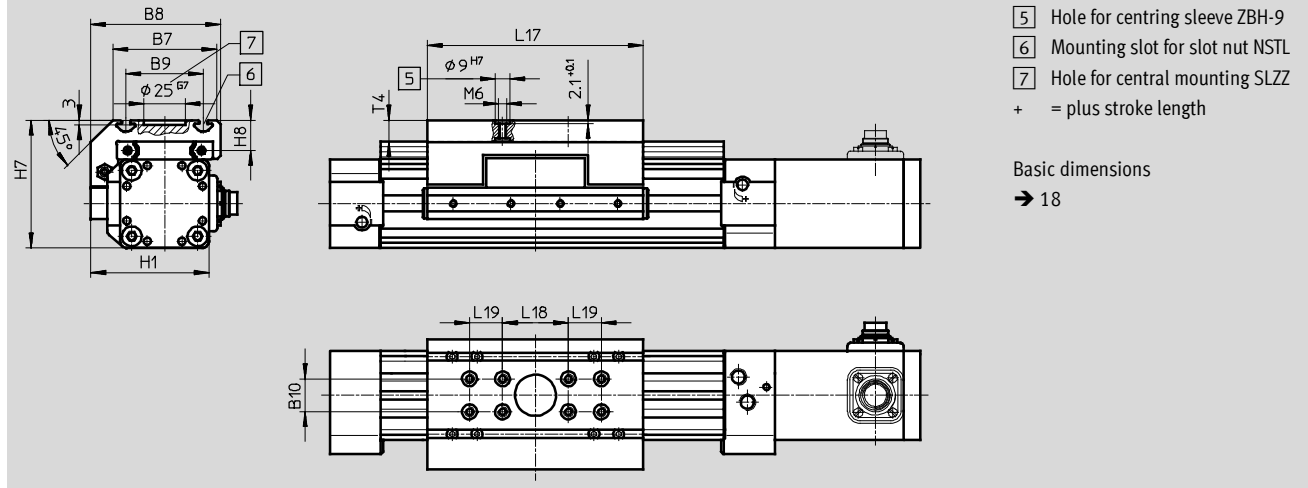

Protected version GA

Piston \varnothing 32/40

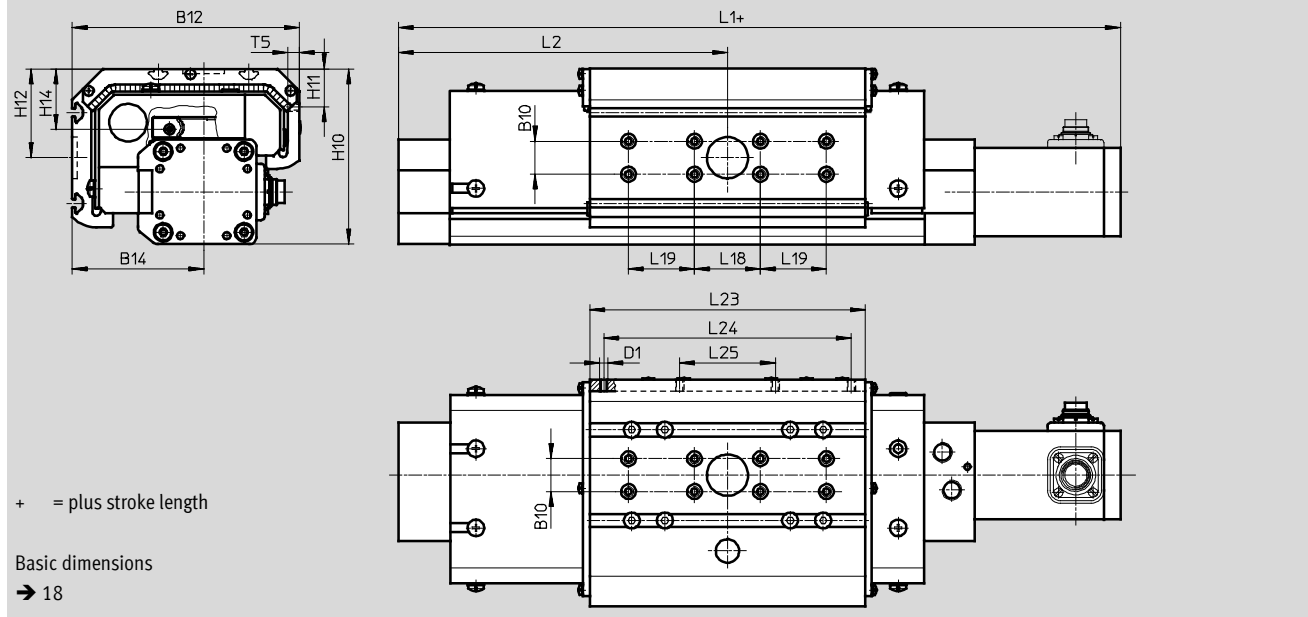

\varnothing [mm]	B7	B8	B9	B10 ± 0.03	B12	B14	D1	H1	H7	H8	H10
32	63	79	47 ± 0.15	20	112.1	67.6	-	72	77.5	18.5	93.1
40	78.5	96.5	55 ± 0.2	20	137.6	79.6	M5	86	90.5	20	106.6
50	97	122	72 ± 0.2	40	-	-	-	115	122.5	26	-
63	121	142	90 ± 0.25	40	-	-	-	131	144.5	30	-

\varnothing [mm]	H11	H12	H14	L1	L2	L17 ± 0.2	L18 ± 0.03	L19 ± 0.03	L23	L24	L25	T4 max.	T5
32	-	49.5	34.1	345	125	131	40	-	131	-	-	12.5	-
40	23.1	54	36.1	397	150	167	40	40	167	150	58	12.5	7
50	-	-	-	465	175	202	40	40	-	-	-	18.5	-
63	-	-	-	513	200	230	40	40	-	-	-	20.5	-

- 1 - Type discontinued
Available up until 2014

Linear drives DGPIIL, with integrated displacement encoder

Ordering data – Modular products

FESTO

Order code

Mandatory data

- KF Recirculating ball bearing guide
- SH Slide at rear
- SV Slide at front
- D2 Supply port at both ends
- GK Standard slide

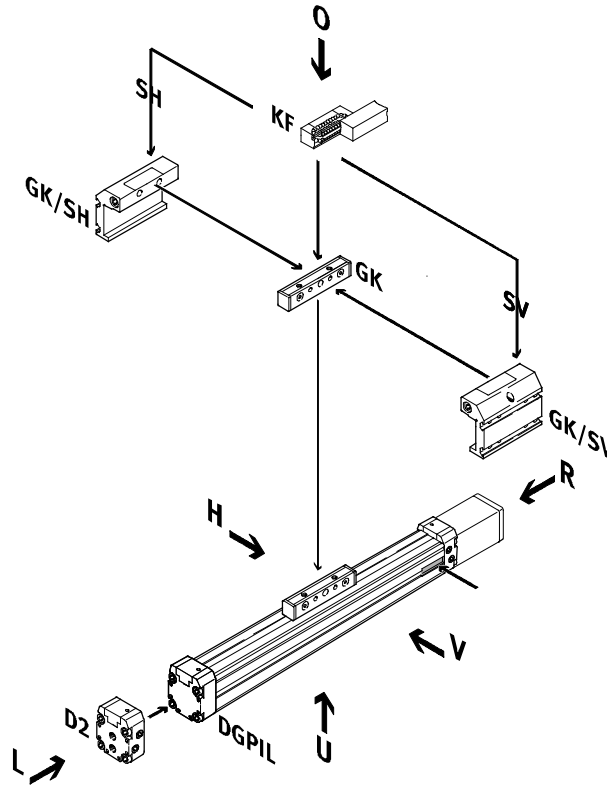

- AV Displacement encoder connection to front
- AH Displacement encoder connection to rear
- AU Displacement encoder connection underneath

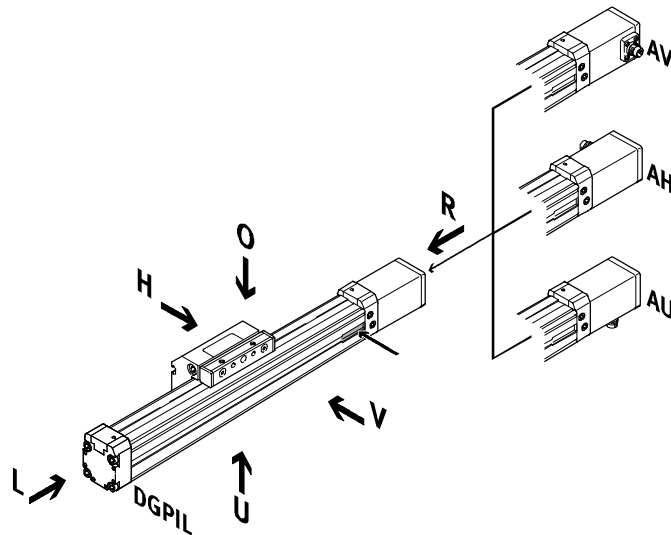

- GA Protected version

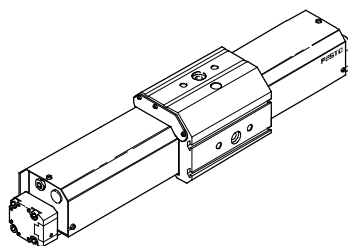

- 2 - Type discontinued
Available up until 2014

FESTO

Linear drives DGPIIL, with integrated displacement encoder

Ordering data – Modular products

Order code

Options

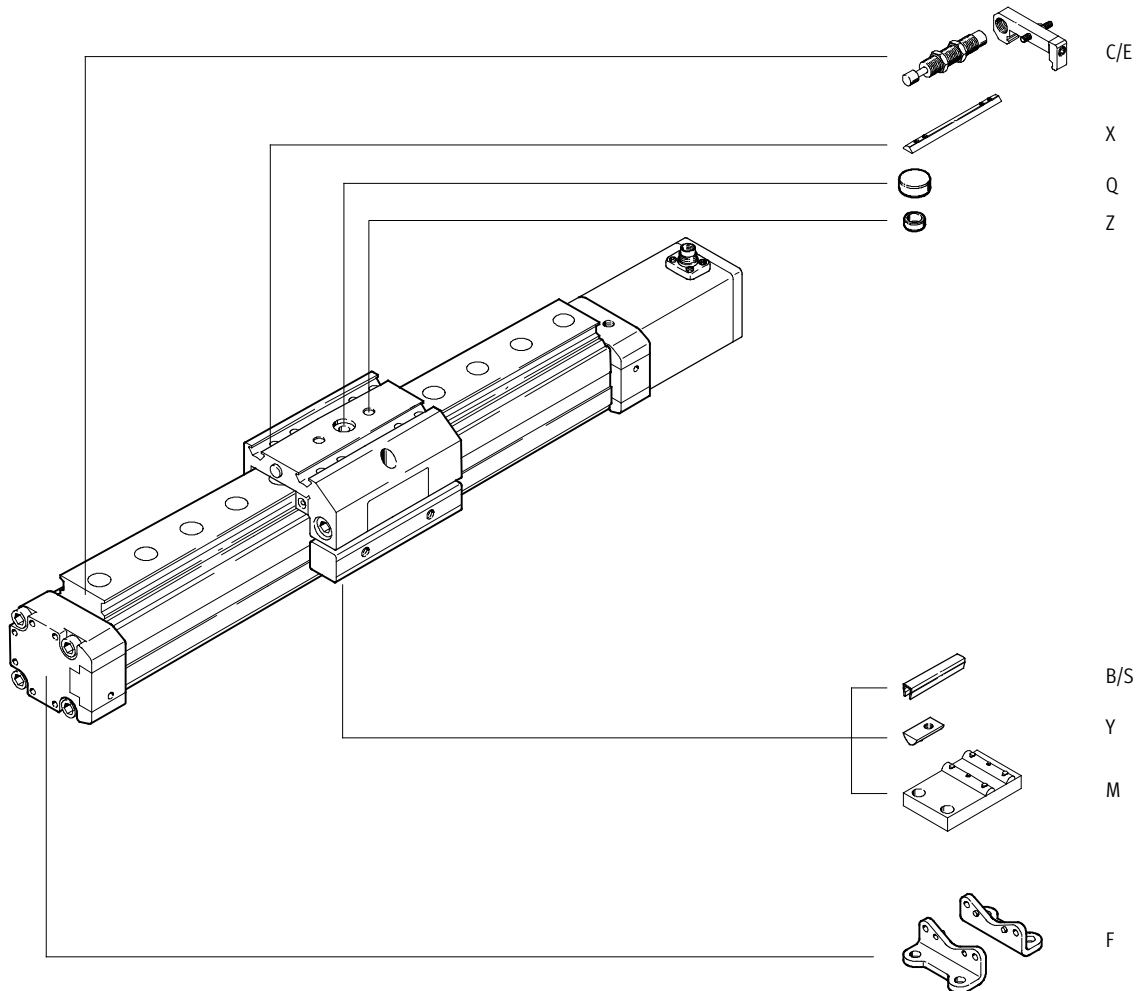

- 1 - Type discontinued
Available up until 2014

Linear drives DGPIIL, with integrated displacement encoder

FESTO

Ordering data – Modular products

M Mandatory data →										
Module No.	Function	Size	Stroke	Cush- ioning	Gener- ation	Guide	Displace- ment encoder	Basic design	Connection posi- tion for displace- ment encoder	Slide at- tachment position
175 134	DGPIIL	25	225 ... 2,000	PPV	B	KF	AIF	GK	AH AU AV	SH SV
175 135		32								
175 136		40								
175 137		50								
175 138		63								
Ordering example										
175 134	DGPIL	- 25	- 450	- PPV	- B	- KF	- AIF	- GK	- AU	- SH

Ordering table										
Size	25	32	40	50	63	Condi- tions	Code	Enter code		
M Module No.	175 134	175 135	175 136	175 137	175 138					
Function	Pneumatic linear drive with integrated displacement encoder and slide							DGPIL		DGPIL
Size	25	32	40	50	63		-...			
Stroke [mm]	225; 300; 360; 450; 500; 600; 750; 1,000; 1,250; 1,500; 1,750; 2,000							-...		
Cushioning	Pneumatic cushioning, adjustable at both ends							-PPV		-PPV
Generation	B series							-B		-B
Guide	Recirculating ball bearing guide							-KF		-KF
Displacement encoder	Temposonic with CAN axis interface							-AIF		-AIF
Basic design	Standard piston/slide							-GK		-GK
Connection position for displacement encoder AIF and compressed air	Connection position for displacement encoder and supply port, rear							-AH		
	Connection position for displacement encoder and supply port, underneath							-AU		
	Connection position for displacement encoder and supply port, front							-AV		
Slide attachment position	Slide at rear							-SH		
	Slide at front							-SV		

Transfer order code

DGPIL - - - **PPV** - **B** - **KF** - **AIF** - **GK** - -

- 2 - Type discontinued
Available up until 2014

Linear drives DGPII, with integrated displacement encoder

FESTO

Ordering data – Modular products

Options

Supply port	Protected version	Accessories	Slot cover	Slot nut	Centring sleeve	Central support	Central mounting	Foot mounting	Shock absorber
D2	GA	ZUB	...S ...B	...X ...Y	...Z	...M	...Q	...F	...C ...E
- D2	-	: ZUB	- 2S2B	2X				F	2C

Ordering table

Size	25	32	40	50	63	Condi- tions	Code	Enter code
Supply port	At both ends						-D2	
Protected version	Protected roller design for harsh environment					-	-GA	
Accessories	Enclosed separately						:ZUB-	:ZUB-
Slot cover, 2 pcs., 0.5 m	Sensor slot	1 ... 10					...S	
	Mounting slot	-	1 ... 10				...B	
Slot nut	Slide	1 ... 10					...X	
	Mounting slot	-	1 ... 10				...Y	
Centring sleeve (pack of 10)	10, 20, 30, 40, 50, 60, 70, 80, 90						...Z	
Central support	1 ... 10						...M	
Central mounting	1 ... 10						...Q	
Foot mounting	1 ... 10						...F	
Shock absorber kit	With retainer, 1-fold	1 ... 10					[1] ...C	
		1 ... 10					[2] ...E	

- [1] C Not with protected version GA.
- [2] E Only with protected version GA.

Transfer order code

- [] - [] : ZUB - [] [] [] [] [] [] [] []

Linear drives DGPL/DGPI/DGPIL

Accessories

Foot mounting HP (order code: F)

Material: Galvanised steel
Free of copper, PTFE and silicone

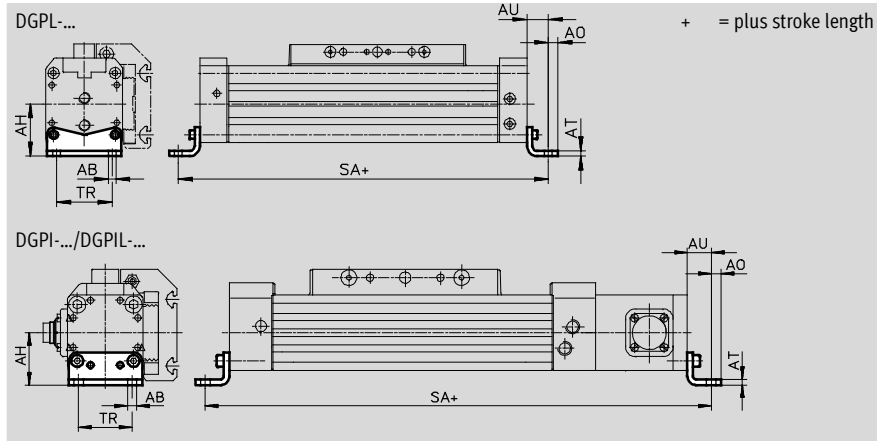

Dimensions and ordering data											
For Ø [mm]	AB Ø	AH	AO	AT	AU	SA		TR	Weight [g]	Part No.	Type
						DGPL	DGPI(L)				
25	5.5	29.5	6	3	13	226	327	32.5	61	150 731	HP-25
32	6.6	37	7	4	17	284	379	38	117	150 732	HP-32
40	6.6	46	8.5	5	17.5	335	432	45	188	150 733	HP-40
50	9	61	11	6	25	400	515	65	243	150 734	HP-50
63	11	69	13.5	6	28	456	569	75	305	150 735	HP-63

Central support MUP (order code: M)

Material: Galvanised steel
Free of copper, PTFE and silicone

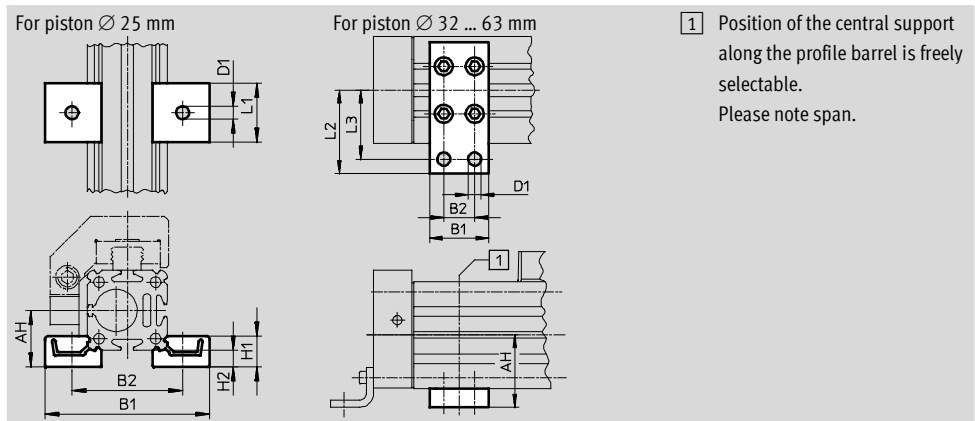

Dimensions and ordering data												
For Ø [mm]	AH	B1	B2	D1 Ø	H1	H2	L1	L2	L3	Weight [g]	Part No.	Type
32	37	35	22	6.6	-	-	-	41.5	35	89	150 737	MUP-32
40	46	35	22	6.6	-	-	-	47	40	126	150 738	MUP-40
50	61	50	26	11	-	-	-	70	58	241	150 739	MUP-50
63	69	50	26	11	-	-	-	77	65	340	150 800	MUP-63

Linear drives DGPL/DGPI/DGPIL

Accessories

Shock absorber DG-GA

for DGPIL

Protected version GA

(order code: E)

Materials:

Housing: Galvanised steel

Piston rod: High-alloy steel

Seals: NBR, PUR

Free of copper, PTFE and silicone



Ordering data			
For Ø [mm]	Weight [g]	Part No.	Type
25	70	192 875	DG-GA-25-YSR
32	110	192 876	DG-GA-32-YSR
40	140	192 877	DG-GA-40-YSR

Shock absorber YSR-...-C

for DGPL/DGPIL

(order code: C)

Materials:

Housing: Galvanised steel

Piston rod: High-alloy steel

Seals: NBR, PUR

Free of copper, PTFE and silicone



-  - Note

Shock absorber YSRW with progressive characteristics
 → Internet: ysrw

Ordering data			
For Ø [mm]	Weight [g]	Part No.	Type
25	70	34 572	YSR-12-12-C
32	70	34 572	YSR-12-12-C
40	140	34 573	YSR-16-20-C
50	140	34 573	YSR-16-20-C
63	240	34 574	YSR-20-25-C

Linear drives DGPL/DGPI/DGPIL

Accessories

FESTO

Shock absorber retainer KYP

for DGPL/DGPIL

(order code: C)

Materials:

Retainer: Aluminium

Sleeve: Corrosion-resistant steel

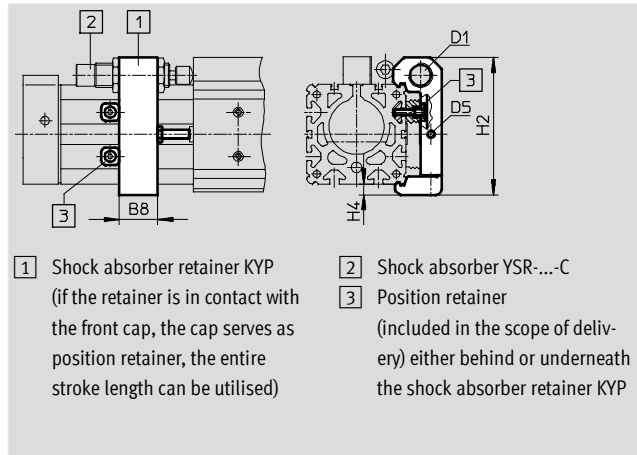

- 1 Shock absorber retainer KYP
(if the retainer is in contact with the front cap, the cap serves as position retainer, the entire stroke length can be utilised)
- 2 Shock absorber YSR-...-C
- 3 Position retainer
(included in the scope of delivery) either behind or underneath the shock absorber retainer KYP

Dimensions and ordering data								
For Ø [mm]	B8	D1	D5	H2	H4	Weight [g]	Part No.	Type
25	19	M16x1	M5	69.5	6	95	158 908	KYP-25
32	25	M16x1	M5	80	8	130	158 909	KYP-32
40	32	M22x1.5	M5	102	8	209	158 910	KYP-40
50	35	M22x1.5	M8	124	10	415	158 911	KYP-50
63	44	M26x1.5	M10	152.5	11.5	609	158 912	KYP-63



Ordering data – Push-in fittings			Technical data → Internet: quick star		
	For Ø [mm]	Comment	Part No.	Type	PU ¹⁾
	25, 32	For connecting compressed air tubing with standard O.D.	186 098	QS-G¹/₈-8	10
	40, 50		186 099	QS-G¹/₄-8	
	63		186 101	QS-G¹/₄-10	10
			186 100	QS-G³/₈-8	10
			186 102	QS-G³/₈-10	
			186 103	QS-G³/₈-12	

1) Packaging unit

Linear drives DGPL/DGPI/DGPIL

Accessories

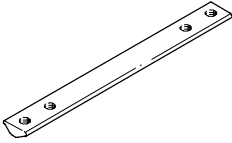
FESTO

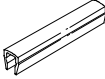
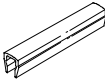
Ordering data				Technical data → Internet: mounting component		
	For Ø [mm]	Comment	Order code	Part No.	Type	PU ¹⁾
Slot nut NST						
	25	For mounting slot	Y	526 091	NST-HMV-M4	1
	32, 40			150 914	NST-5-M5	1
	50, 63			150 915	NST-8-M6	1
Slot nut NSTL						
	25	For slide	X	158 410	NSTL-25	1
	32			158 411	NSTL-32	1
	40			158 412	NSTL-40	1
	50			158 413	NSTL-50	1
	63			158 414	NSTL-63	1
Centring sleeve ZBH						
	25 ... 63	For slide	Z	150 927	ZBH-9	10
Central mounting SLZZ						
	25	For slide	Q	150 900	SLZZ-16/10	1
	32, 40			150 901	SLZZ-25/16	1
	50, 63			150 904	SLZZ-50/40	1
Slot cover ABP						
	32, 40	For mounting slot Every 0.5 m	B	151 681	ABP-5	2
	50, 63			151 682	ABP-8	
Slot cover ABP-S						
	25 ... 63	For sensor slot Every 0.5 m	S	563 360	ABP-5-S1	2

1) Packaging unit

Linear drives DGPL/DGPI/DGPIL

FESTO

Accessories

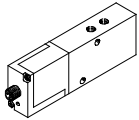
Ordering data – Proportional directional control valves											Technical data → Internet: mpye				
Selection aid															
Application	For Ø [mm]	Stroke [mm]													
		225	300	360	450	500	600	750	1,000	1,250	1,500	1,750	2,000		
Horizontal/vertical	For applications with axis controller SPC200														
	25	1/1	1/1	1/1	1/1	1/1	1/1	1/1	1/1	2/2	2/2	2/2	2/2	2/2	
	32	1/1	1/1	2/2	2/2	2/2	2/2	2/2	2/2	2/2	2/2	2/2	2/2	2/2	
	40	1/1	2/2	2/2	2/2	2/2	2/2	2/2	2/2	3/3	3/3	3/3	3/3	3/3	
	50	2/2	2/2	2/2	2/2	2/2	3/3	3/3	3/3	3/3	3/3	3/3	3/3	3/3	
	63	3/3	3/3	3/3	3/3	3/3	3/3	3/3	3/3	3/3	4/4	4/4	4/4	4/4	
	For applications with Soft Stop end-position controller SPC11														
	25	1 ¹⁾	1/1	2/1	2/1	2/1	2/2	2/2	2/3	2/3	2/3	2/3	2/3	2/3	
	32	1 ¹⁾	2/1	2/1	2/1	2/1	2/1	3/2	3/3	3/3	3/3	3/3	3/3	3/3	
	40	2/1	2/1	2/1	2/1	2/2	3/3	3/4	3/4	3/4	3/4	3/4	3/4	3/4	
	50	1/1	2/1	2/2	3/2	3/3	4/3	4/4	4/4	4/4	4/4	4/4	4/4	4/4	
	63	2/1	2/2	3/3	3/3	4/4	4/4	4/4	4/4	4/4	4/4	4/4	4/4	4/4	
	Valve	Selection number							Part No.	Type					
		1							151 692	MPYE-5-1/8-LF-010-B					
2							151 693	MPYE-5-1/8-HF-010-B							
3							151 694	MPYE-5-1/4-010-B							
4							151 695	MPYE-5-3/8-010-B							

1) On request

-  - Note



The representation e.g. 2/1 in the columns means:



Selection number 2 for horizontal application	Selection number 1 for vertical application
151 693 MPYE-5-1/8-HF-010-B	151 692 MPYE-5-1/8-LF-010-B



Linear drives DGPL/DGPI/DGPIL

Accessories

FESTO

Ordering data – Proximity sensor for T-slot, magnetic reed						Technical data → Internet: sme	
	Type of mounting	Switching output	Electrical connection	Cable length [m]	Part No.	Type	
N/O contact							
	Insertable in the slot lengthwise, flush with the cylinder profile	Contacting	Cable, 3-wire	2.5	150 855	SME-8-K-LED-24	
			Plug M8x1, 3-pin	0.3	150 857	SME-8-S-LED-24	
N/C contact							
	Insertable in the slot lengthwise, flush with the cylinder profile	Contacting	Cable, 3-wire	7.5	160 251	SME-8-O-K-LED-24	

Ordering data – Proximity sensor for T-slot, magneto-resistive						Technical data → Internet: smt	
	Type of mounting	Switching output	Electrical connection	Cable length [m]	Part No.	Type	
N/O contact							
	Insertable in the slot from above, flush with the cylinder profile, short design	PNP	Cable, 3-wire	2.5	574335	SMT-8M-A-PS-24V-E-2,5-OE	
N/C contact							
	Insertable in the slot from above, flush with the cylinder profile, short design	PNP	Cable, 3-wire	7.5	574340	SMT-8M-A-PO-24V-E-7,5-OE	

Ordering data – Connecting cables					Technical data → Internet: nebu	
	Electrical connection, left	Electrical connection, right	Cable length [m]	Part No.	Type	
	Straight socket, M8x1, 3-pin	Cable, open end, 3-wire	2.5	541 333	NEBU-M8G3-K-2.5-LE3	
			5	541 334	NEBU-M8G3-K-5-LE3	
	Angled socket, M8x1, 3-pin	Cable, open end, 3-wire	2.5	541 338	NEBU-M8W3-K-2.5-LE3	
			5	541 341	NEBU-M8W3-K-5-LE3	